

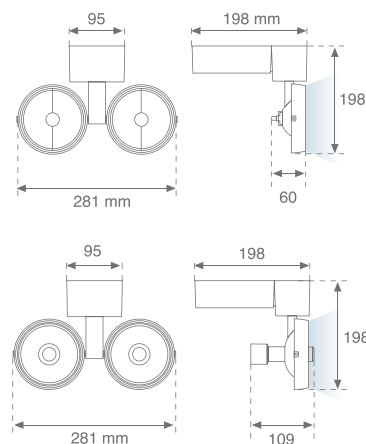

Proyector con adaptador a carril trifásico universal o base para superficie. Giratorio y orientable 355°. Fabricado en aluminio de inyección y acabado en color gris. Para lámparas de acento QR-111 y CDM-R111.

Projector with adapter for mounting on a universal three-phase track or with a base for surface mounting. Can rotate and tilt through 355°. Manufactured in die cast aluminium and finished in grey. For CDM-R111 and QR-111 accent lamps.



Proyector TWIN para 2 lámparas halógenas
TWIN Projector for 2 halogen lamps



Lamp.	Equipo / Gear	Ref. Techo Ref. Ceiling	Ref. Carril Ref. Track	Color	W	Plum
	Electrónico Electronic	73.42.03.3	73.42.13.3	■	2 x max.100	2x100W

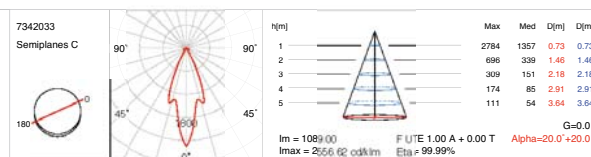

Proyector TWIN para 2 lámparas de descarga
TWIN Projector for 2 discharge lamps

Lamp.	Equipo / Gear	Ref. Techo Ref. Ceiling	Ref. Carril Ref. Track	Color	W	Plum
	Electrónico Electronic	73.42.04.3	73.42.14.3	■	2 X 35	78,2W

