

Presionar y girar.

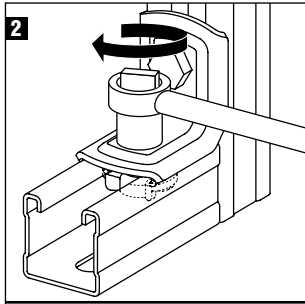

Apretar.