

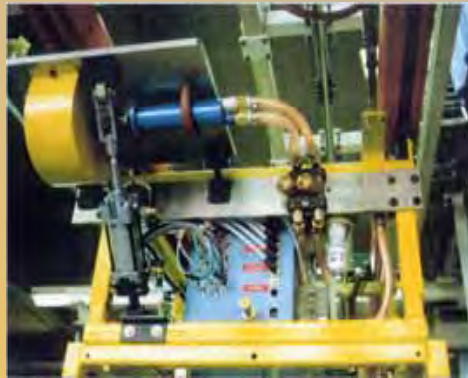

MANIPULACIÓN





*Manipulador de dos ejes + giro + pinza.
Empresa auxiliar del automóvil*





*Manipulador de dos ejes + giro + pinza.
Empresa auxiliar del automóvil*





*Manipulador de tres ejes + giro + pinza.
Empresa fabricante de contadores para agua*





Manipulador de un eje. Empresa fabricante de sistemas de impresión por chorro de tinta





Manipuladores de dos ejes + pinza. Máquina de ensamblado rotativa





Dispositivo volteador mediante mesa de indexado neumática, con amortiguación hidráulica





*Máquina rotativa de ensamblado automático
de válvulas para electrodomésticos*

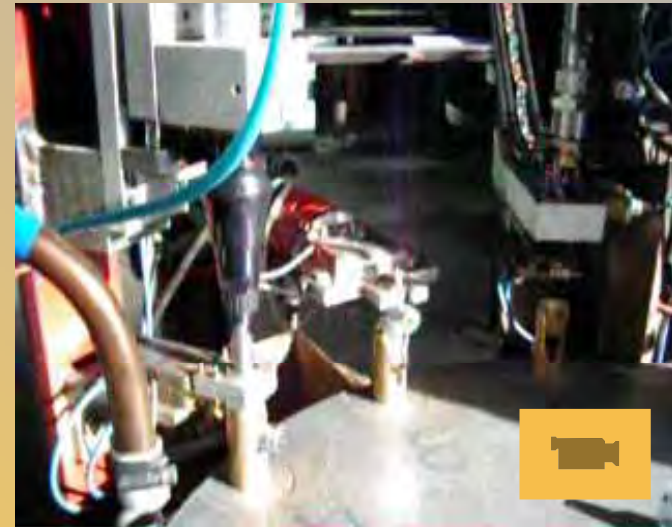



Máquina lineal de ensamblado automático





Manipulador de dos ejes + giro con cambio de plano+ pinza. Alimentador de piezas

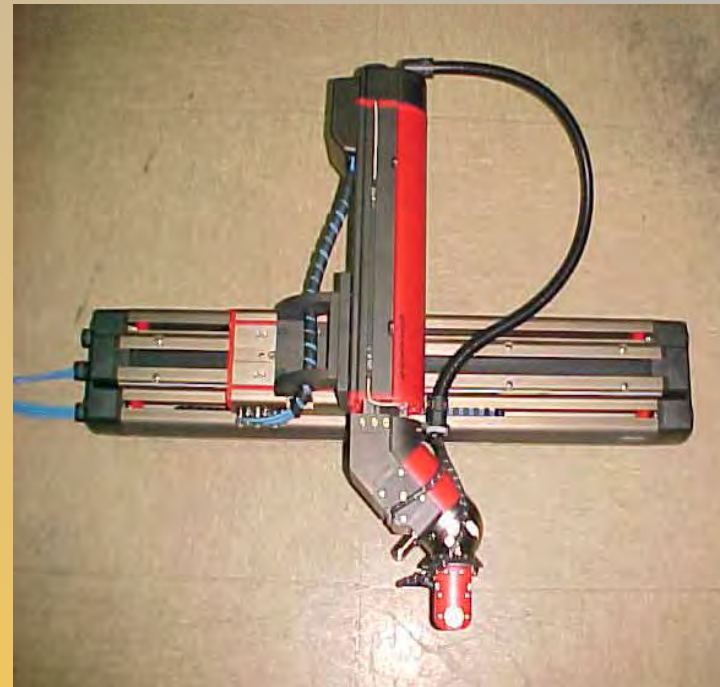



*Manipulador de dos ejes + giro + vacío.
Empresa fabricante de material eléctrico*





Manipulador de un eje + pinza. Alimentador de piezas a máquina rectificadora.





Manipulador doble e independiente, con dos ejes verticales + giro + pinza. Empresa fabricante de bombas de alta presión





*Manipulador horizontal con doble eje vertical
+ pinzas. Línea de troquelado*

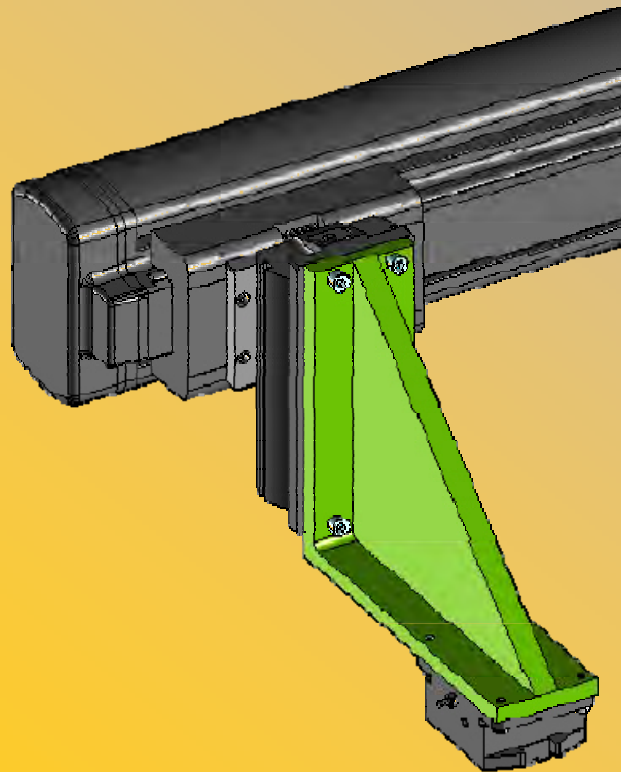

1E21NNU0KZ0A1-5Z

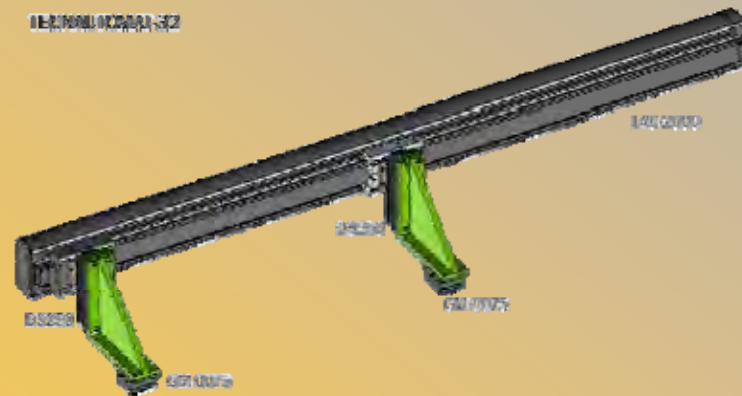



Manipulador de dos ejes + giro con cambio de plano+ pinza. Empresa auxiliar del automóvil





*Manipulador de dos ejes + dos pinzas sobre
placa especial interface*





Manipulador de tres ejes, uno giratorio + pinza
Manipulador de tres ejes + giro + pinza





*Manipuladores de dos ejes + giro con cambio
de plano + dos pinzas*





Manipulador de tres ejes, el vertical combinado con una pinza

Manipulador de dos ejes, el vertical combinado con una pinza + giro

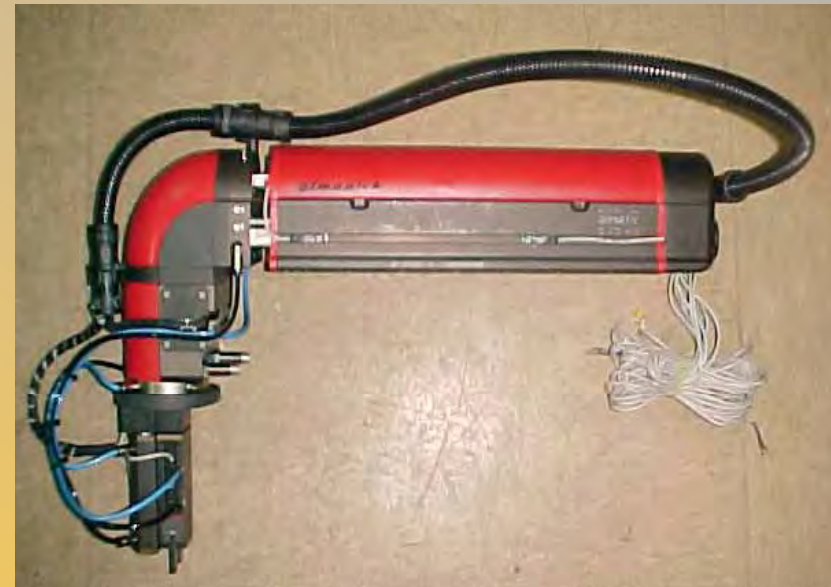
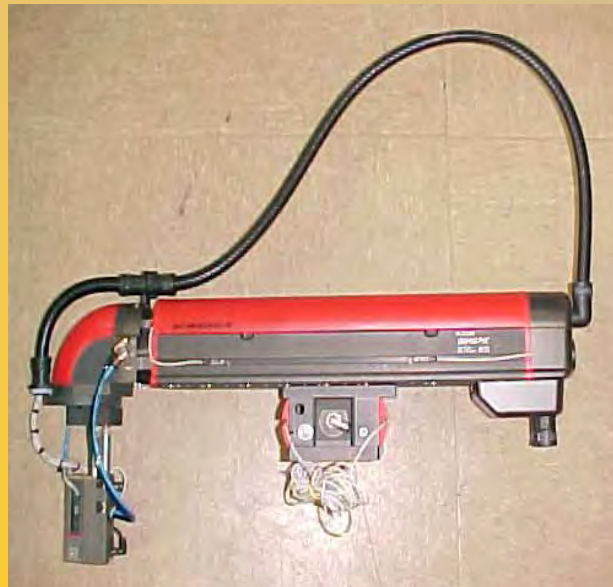



*Manipulador de dos ejes, el horizontal con paradas
intermedias + giro + pinza*
*Manipulador de dos ejes, el horizontal de carrera corta
+ placa interface especial+ pinza*

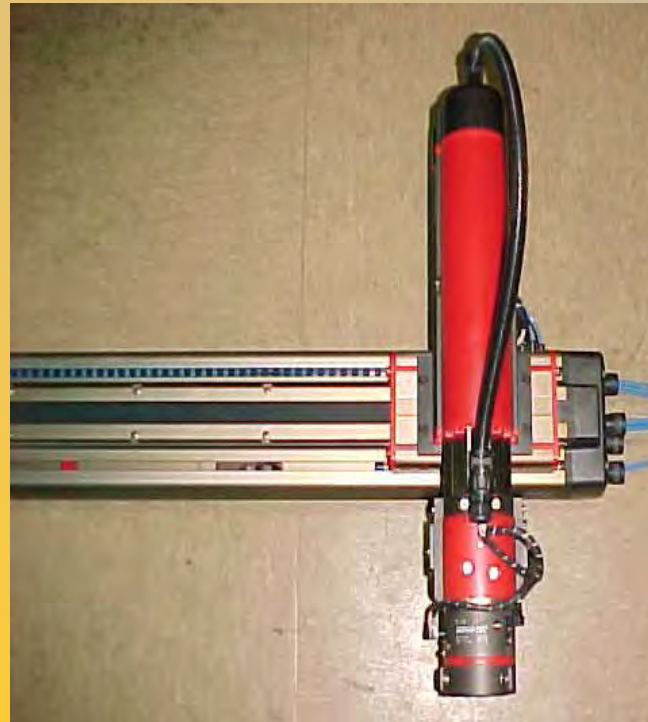



*Manipulador de dos ejes, el horizontal con
paradas intermedias + pinza*

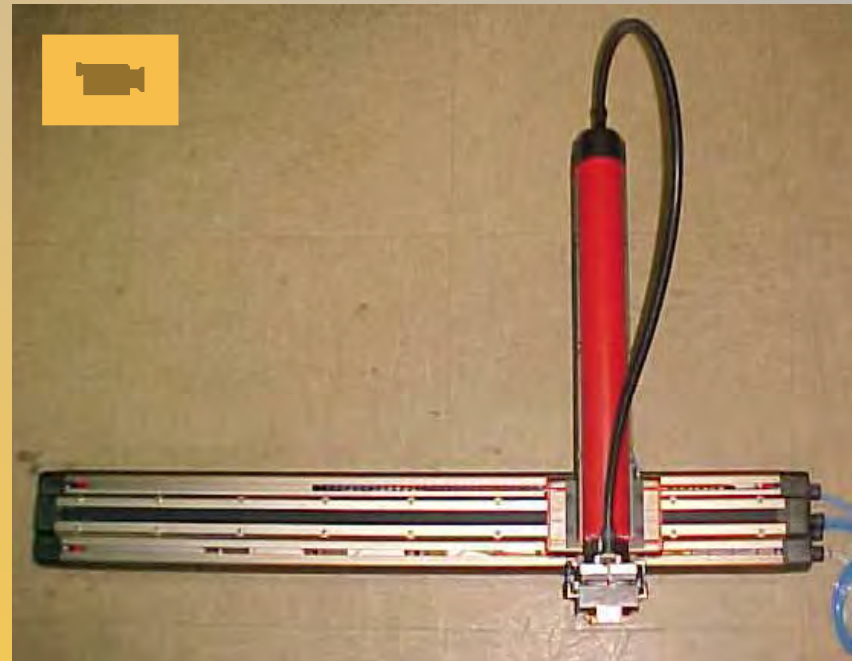



*Manipulador de dos ejes, el horizontal con paradas intermedias +
Sistema de vacío y ventosas*
Manipulador de dos ejes + pinza
Manipulador de dos ejes+ dos pinzas

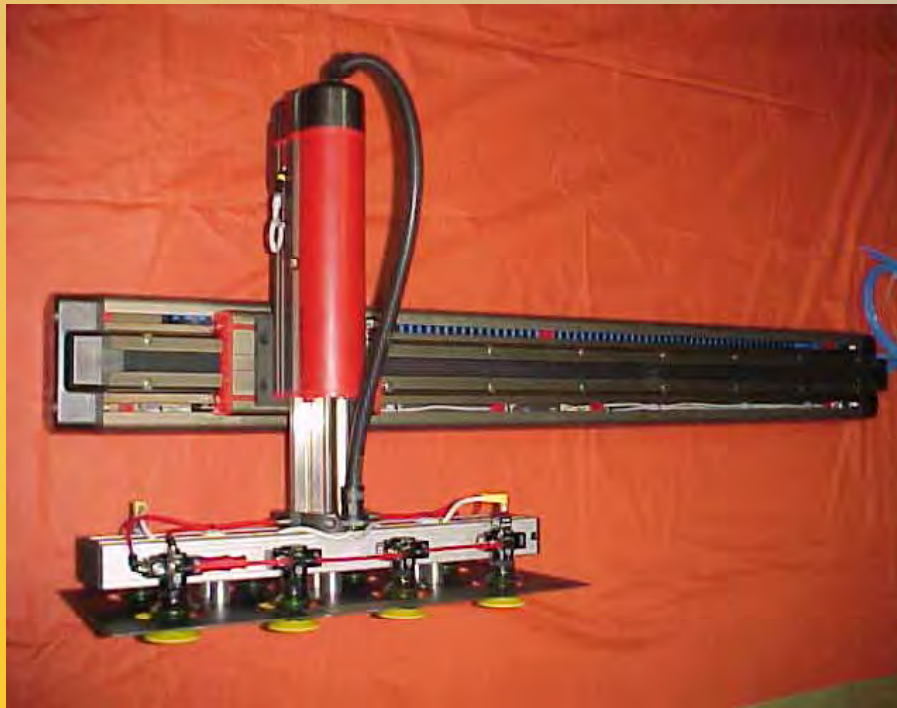



Manipuladores de dos ejes con mesas lineales





Manipulador + giro con cambio de plano + pinza
Manipuladores + giro
Manipulador + giro con cambio de plano + giro + pinza





Aplicaciones con motores neumáticos de pistones
Carros de transporte en la industria del automóvil
Mesas de elevación en una fábrica de proyectiles
Motorización de puentes grúa en barcos

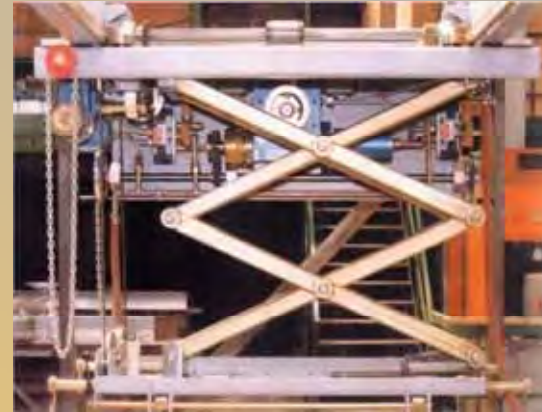



*Aplicaciones con motores neumáticos de pistones
Motorización de cabrestantes para la industria en
general y minera en particular*

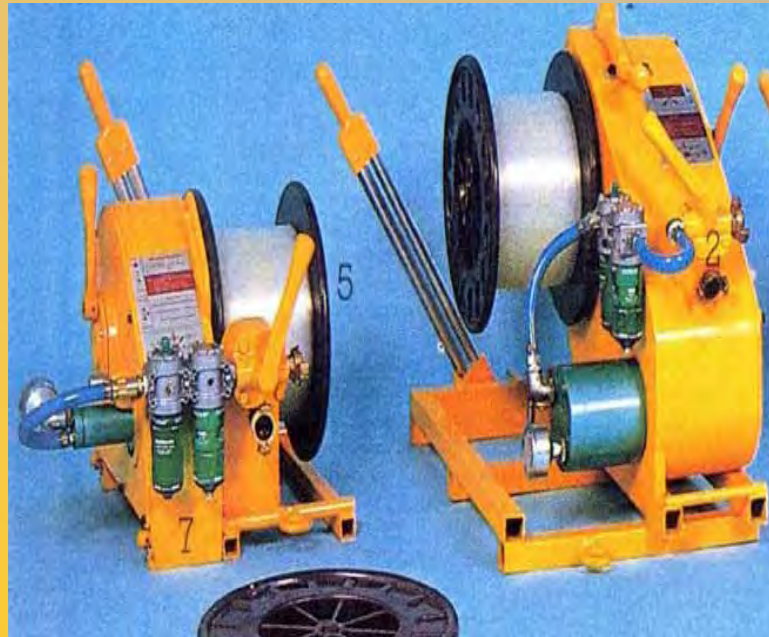



Aplicaciones con mesas rotativas y pinzas de mecanizado

