

CD STANDARD / STANDARD			
Cilindro según norma <i>Standard cylinders</i>	ISO 6020/2 - 1991 a tiranti / <i>tie rods</i>	DIN 24554	
Presion <i>Pressure</i>	trabajo <i>operating</i> 160	máxima <i>peak</i> 210	prueba <i>test</i> 240
Velocidad máxima <i>Max speed</i>	standard 0.5	baja fricción / <i>low-friction</i> (Y) (W) 1	
Temperatura fluido <i>Fluid temperature</i>	standard -20 +80	Viton® W -20 +150	
Carrera máxima <i>Max stroke</i>	4000		
Tolerancia para carrera <i>Stroke tolerance</i>	0 + 2 mm Norma ISO 8131		
Fluido <i>Fluid</i>	Aceite hidraulico mineral / <i>Hydraulic mineral oil</i> Ester fosforico / <i>Phosphoric esters</i> (W) Agua-glicol / <i>HFC-fluid</i> (N)		
Viscosidad / <i>Viscosity</i>	12... 90 mm²/S		

MD MAGNÉTICO / MAGNETIC			
Cilindro según norma <i>Standard cylinders</i>	ISO 6020/2	DIN 24554 a tiranti / <i>tie rods</i>	
Presion <i>Pressure</i>	trabajo <i>operating</i> 160	máxima <i>max</i> 160	
Velocidad máxima <i>Max speed</i>	standard 0.5	baja fricción / <i>low-friction</i> (Y) (W) 1	
Temperatura fluido <i>Fluid temperature</i>	standard -20 +80	Viton® W -20 +150	
Carrera máxima <i>Max stroke</i>	4000	Carrera mínima <i>Minimum stroke</i>	50
Tolerancia para carrera <i>Stroke tolerance</i>	0 + 2 mm Norma ISO 8131		
Fluido <i>Fluid</i>	Aceite hidraulico mineral / <i>Hydraulic mineral oil</i> Ester fosforico / <i>Phosphoric esters</i> (W) Agua-glicol / <i>HFC-fluid</i> (N)		
Viscosidad / <i>Viscosity</i>	12... 90 mm²/S		

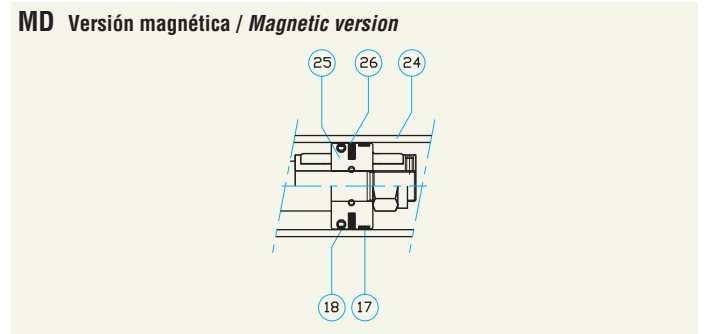
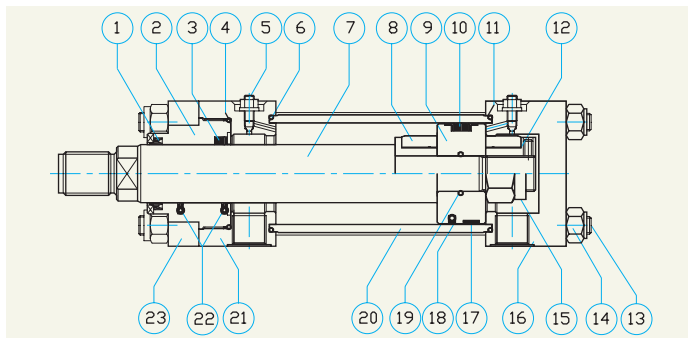

Ref. Ref.	Componentes <i>Components</i>	Material <i>Material</i>	Especificaciones <i>Specifications</i>
1	Rascador <i>Wiper</i>	Poliuretano <i>Polyurethane</i>	
2	Guía vástago <i>Guide bushing</i>	Bronce <i>Bronze</i>	
3	Junta vástago (standard) <i>Rod seal (standard)</i>	Poliuretano <i>Polyurethane</i>	
4	Junta OR con aro antiextrusion <i>O-Ring seal with anti-extrusion</i>	Goma nitrilo + ptfe <i>Nitrile rubber + ptfe</i>	
5	Tornillo de regul. amortig. (tapon) <i>Cushioning adjusting (air bleeder)</i>	Acero <i>Steel</i>	
6	Junta OR <i>O-Ring seal</i>	Goma nitrilo <i>Nitrile rubber</i>	
7	Vástago <i>Piston rod</i>	Acero cromado <i>Chromeplated steel</i>	spess. 0.025 mm ISO f7 - Ra 0.20 µm
8	Amortiguación anterior <i>Front cushioning</i>	Acero templado <i>Tempered steel</i>	
9	Pistón <i>Piston</i>	Acero <i>Steel</i>	
10	Junta pistón (standard) <i>Piston seal (standard)</i>	NBR/Acetal/POM <i>NBR/Acetal/POM</i>	
11	Junta OR <i>O-Ring seal</i>	Goma nitrilo <i>Nitrile rubber</i>	
12	Amortiguación posterior <i>Rear cushioning</i>	Acero templado <i>Tempered steel</i>	
13	Tirante <i>Tie rod</i>	Acero endurecido <i>Hardened steel</i>	Laminado <i>Rolled</i>

Ref. Ref.	Componentes <i>Components</i>	Material <i>Material</i>	Especificaciones <i>Specifications</i>
14	Tuerca autoblocante para tirante <i>Tie-rod self-locking nut</i>	Acero <i>Steel</i>	
15	Tuerca autoblocante para vástago <i>Rod self-locking nut</i>	Acero <i>Steel</i>	
16	Cabezal posterior <i>Rear end cap</i>	Acero <i>Steel</i>	Pulido <i>Burnished</i>
17	Pattini antifrizzione (Y) (W) <i>Low-friction bearings (Y) (W)</i>	Resina de fenol <i>Phenolic</i>	
18	Juntas pistón (Y) (W) <i>Piston seal (Y) (W)</i>	Goma nitrilo + ptfe <i>Nitrile rubber + ptfe</i>	Cava <i>Grove</i> ISO 7425/2
19	Juntas OR <i>O-Ring seal</i>	Goma nitrilo <i>Nitrile rubber</i>	
20	Camisa <i>Cylinder body</i>	Acero <i>Steel</i>	Labeado / <i>Honed</i> H8 - Ra 0.40 µm
21	Cabezal anterior <i>Front end cap</i>	Acero <i>Steel</i>	Pulido <i>Burnished</i>
22	Juntas vástago (Y) (W) <i>Rod seals (Y) (W)</i>	Goma nitrilo + ptfe <i>Nitrile rubber + ptfe</i>	Cava <i>Grove</i> ISO 7425/1
23	Cierre brida <i>Closing flange</i>	Acero <i>Steel</i>	Brunito <i>Burnished</i>

MD CILINDRO MAGNETICO / MAGNETIC CYLINDER			
24	Camisa <i>Cylinder body</i>	Tubo no magnético <i>Non-magnetic tube</i>	
25	Pistón magnético <i>Magnetic piston</i>	AISI	
26	Magnético <i>Magnet</i>		

TABLA PARA DETERMINACIÓN CILINDRO / ROD SELECTION CHART

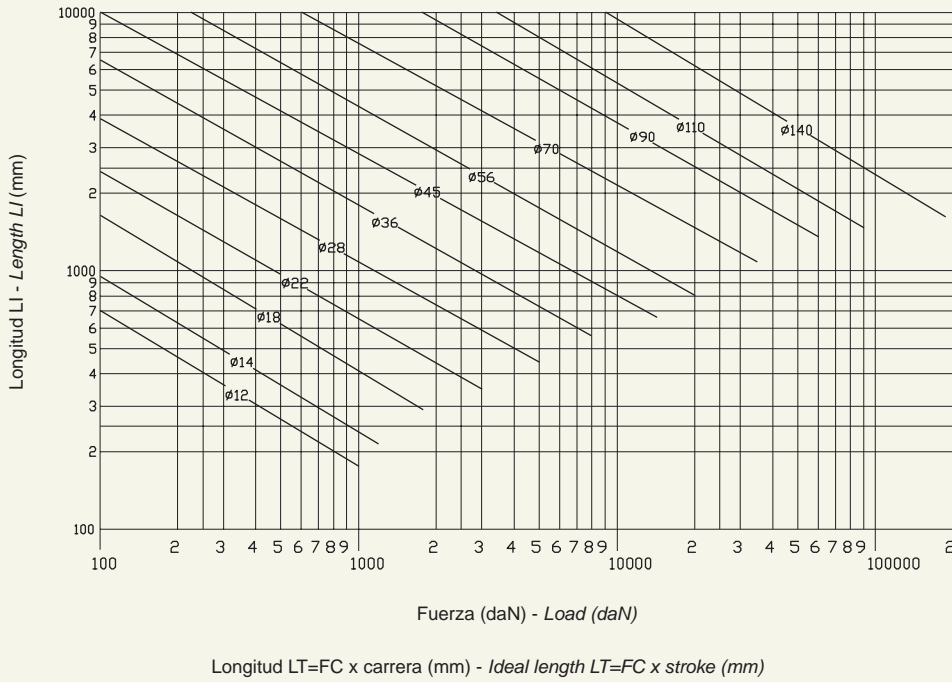

FACTOR DE LA CARRERA "FC"
STROKE "FC" FACTOR

	$F_c = 0.7$
	$F_c = 1.5$
	$F_c = 0.7$
	$F_c = 1$
	$F_c = 1.5$
	$F_c = 2$
	$F_c = 2$
	$F_c = 4$
	$F_c = 2$

SECCIONES DE FRENADO Y CARRERA / BRAKING SECTIONS AND STROKES

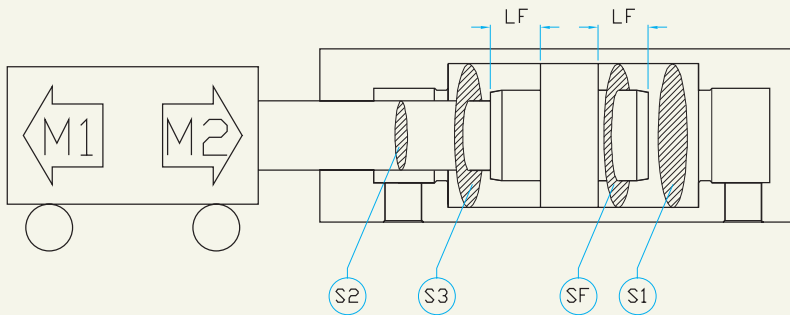

$$\text{Empuje } M1 = \frac{g \cdot (PF \cdot SF - P1 \cdot S1) \cdot LF \cdot 2}{1000 \cdot V^2}$$

$$\text{Tracción } M2 = \frac{g \cdot (PF \cdot SF - P1 \cdot S3) \cdot LF \cdot 2}{1000 \cdot V^2}$$

M1/M2	Fuerza de frenado (daN) Braking load (daN)	P1	Presión de trabajo (bar) Working pressure (bar)
PF	Presión de frenado (máx. 250 bar) Braking pressure (max 250 bar)	S1/S3	Sección de trabajo (cm²) Work section (cm²)
SF	Sección de frenado (cm²) Braking section (cm²)	g	9.81
LF	Longitud de frenado (mm) Braking length (mm)	V	Velocidad (m/sec) Speed (m/sec)

Camisa Piston	Vástago Rod	S1 cm²	S2 cm²	S3 cm²	SF cm²	LF mm
25	12	4.9	1.1	3.8	1.8	12
	18		2.5	2.4		
32	14	8	1.5	6.5	3.5	14
	18		2.5	5.5		
	22		3.8	4.2		
40	18	12.6	2.5	10	5.5	23
	22		3.8	8.8		
	28		6.2	6.4		
50	22	19.6	3.8	15.8	8.3	21
	28		6.2	13.5		
	36		10.2	9.6		
63	28	31.2	6.2	25	13.8	21
	36		10.2	21		
	45		15.9	15.3		
80	36	50.3	10.2	40.1	23.8	28
	45		15.9	34.4		
	56		24.6	25.6		
100	45	78.5	15.9	62.6	37.8	28
	56		24.6	53.9		
	70		38.5	40.1		
125	56	123	25	98	56	26
	70		38	84		
	90		64	59		
160	70	201	38	163	99	30
	90		64	137		
	110		95	106		
200	90	314	64	251	151	44
	110		95	219		
	140		154	160		

DESIGNACION DE CODIGOS / ORDERING CODE

Los campos que contienen valores de ejemplo son obligatorios.
The fields containing sample values are required.

CD 50 / 28 / A 500

Serie / Type	Dimensión camisa / Bore	
Standard	25... 100	CD
	125... 200	DK
Magnético / Magnetic	25... 100	MD

Versiones especiales / Special version (1) **SX**

	Camisa / Bore	Vástago / Rod
CD	25	12
		18
	32	14
		18
	40	22
		28
	50	22
		28
		36
		28
	63	36
		45
80	36	
	45	
100	56	
	45	
	56	
	70	
DK	125	56
		70
	160	90
		70
	200	90
		110
		140

Posible 2º vástago / Possible 2º rod

Consultar pág. 6 / See page 6	ISO 6020/2	DIN24554	Fijación / Mounting
Cilindro base / Front tapped holes	MX5		X
Brida delantera / Front flange	ME5	ME5	A
Brida trasera / Rear flange	ME6	ME6	B
Patas / Feet	MS2	MS2	E
Charmela rotula / Ball jointed eye	MP5	MP5	D
Charmela hembra / Female clavis	MP1		M
Muñón delantero / Front trunnions	MT1		G
Muñón intermedio / Intermediate trunnions (2)	MT4	MT4	H
Muñón trasero / Rear trunnions	MT2		L
Tirantes prolong. ambos lados / Extended front and rear tie-rods	MX1		Q
Tirantes prolongados delanteros / Extended front tie-rods	MX3		R
Tirantes prolongados traseros / Extended rear tie-rods	MX2		S
Fijación posterior / Rear tapped holes	MX6		T

(2) Para fijación H (MT4) - Indicar la cota "XV" (consultar pág. 7)
For mounting H (MT4) - Value dimension "XV" (see page 7)

Sensor Switch	(solo para cilindros MD) indicar cantidad / (only for MD cylinders) specify quantity (cons. pág. 12) / (see page 12)
SR	REED 24-110 V. AC/DC
SH	PNP 24 V. DC

SD	Drenaje guia / Bushing drain
Purgador de aire / Air bleeder	
SV	Sin purgador de aire / No air bleeder
SZ	Delantera / Front only
SK	Trasera / Rear only
	Delantera + trasera / Front and rear

Extremo vástago / Rod extremities (consultar pág. 9 / see page 9)	
	Rosca macho / Male thread (standard)
SF	Rosca hembra / Female thread
ST	Tenón / Tenon
SL	Rosca macho DIN 24554 / Male thread DIN 24554

Juntas / Seals	
	Standard (aceite mineral, agua y glicol) / Standard (mineral oil, water and glicole)
Y	Baja fricción / Low friction
W	Vitón® (alta temperatura, éster fosfórico) / Vitón® (high temperature, phosphoric esters)
N	Agua-glicol / HFC-fluid

Distanciador / Spacer	
	Recomendado para carreras: / Recommended for stroke:
	desde 0 hasta 1000 / from 0 to 1000
SJ 50	desde 1000 hasta 1500 / from 1000 to 1500
SJ 100	desde 1500 hasta 2000 / from 1500 to 2000
SJ 150	desde 2000 hasta 4000 / from 2000 to 4000

Carrera / Stroke	
	Indicar en mm / Specify in mm

Amortiguación / Cushioning	
	Sin amortiguación / Not cushioned
V	Delantera / Front only
Z	Trasera / Rear only
K	Delantera + trasera / Front and rear

(1) Indicar **SX** en caso de no ser standard. (Nomalmente va con un número de plano.)

Versión especial:

- Orientación de la conexiones; conexiones opuestas (consultar pág. 7)
- Roscas especiales en el vástago, vástago prolongado
- Subplacas CETOP (consultar pág. 9)
- Tratamiento del vástago (Nikrom, Endurecido, Aisi, etc.)
- Tapa de protección del vástago
- Dispositivo antirrotación del vástago

Specify **SX** only if different from the standard (It is usually linked to an our drawing number).

Options:

- Oil port position; oversize oil ports (see page 7)
- Special rod extremity, lengthed rod
- CETOP subplates (see page 9)
- Rod treatment (Nikrom, Hardened, Aisi, ecc.)
- Rod protective cover
- Antirotation rod system

CILINDRO BASE / FRONT TAPPED HOLES X (ISO MX5)

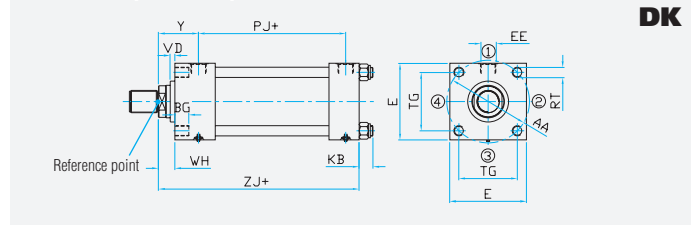
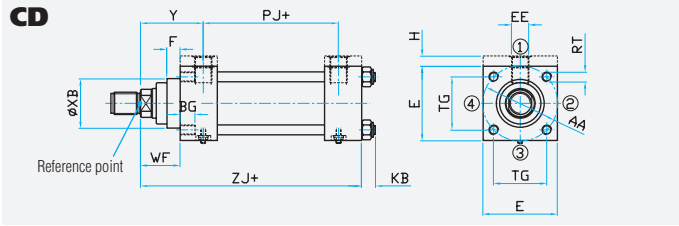

BRIDA DELANTERA / FRONT FLANGE A (ISO ME5)

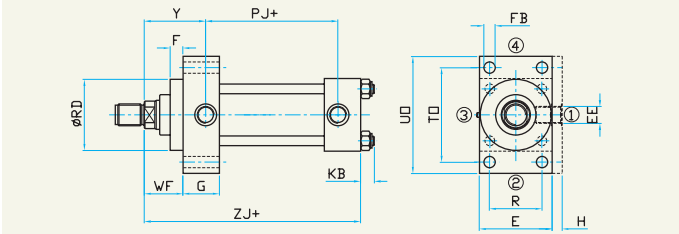

BRIDA TRASERA / REAR FLANGE B (ISO ME6)

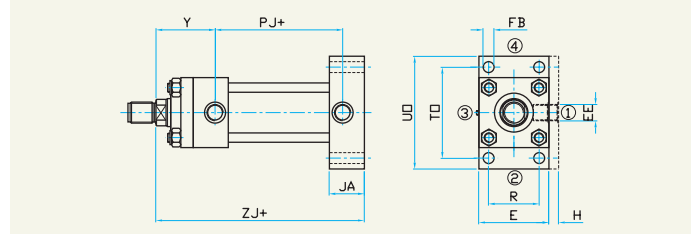

CHARNELA ROTULA / BALL JOINTED EYE D (ISO MP5)

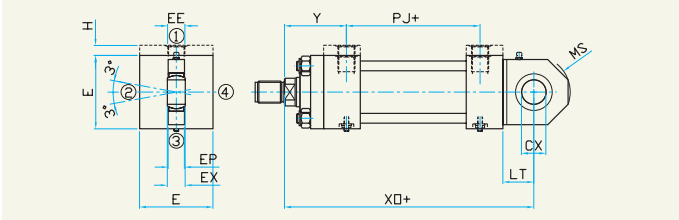

CCHARNELA HEMBRA / FEMALE CLEVIS M (ISO MP1)

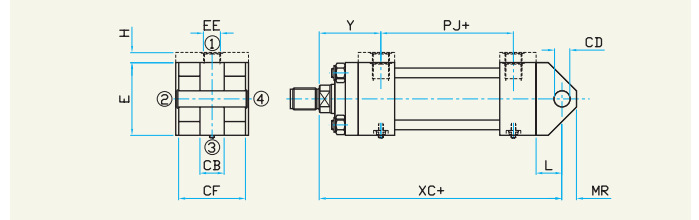

PATAS / FEET E (ISO MS2)

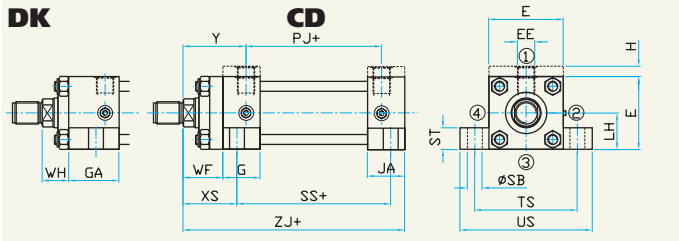

MUÑÓN INTERMEDIO / INTERMEDIATE TRUNNIONS H (ISO MT4)

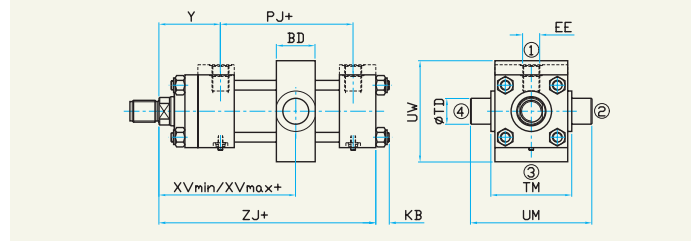

MUÑÓN DELANTERO / FRONT TRUNNIONS G (ISO MT1)

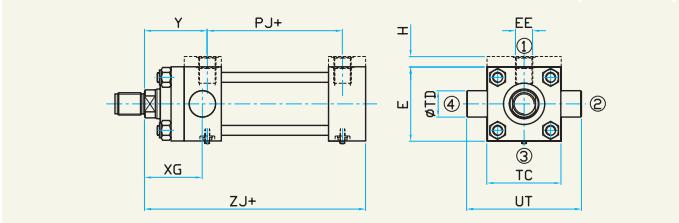

MUÑÓN TRASERO / REAR TRUNNIONS L (ISO MT2)

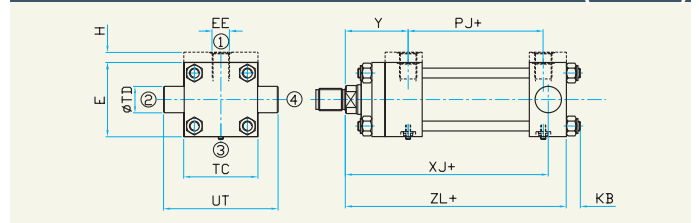

TIRANTES PROLON. DELAN. / EXTENDED FRONT TIE-RODS R (ISO MX3)

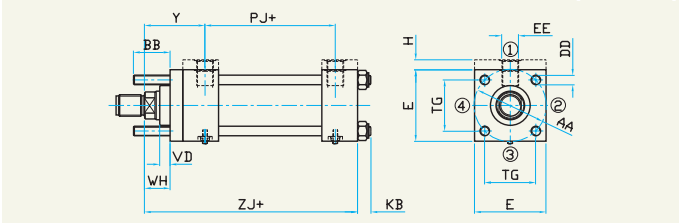

TIRANTES PROLON. TRASEROS / EXT. REAR TIE-RODS S (MX2)

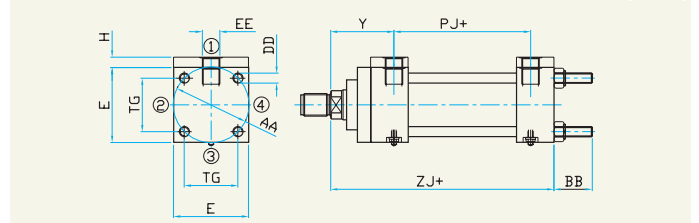

TIR. PROL. AMBOS LADOS / EXT. FRONT AND REAR TIE-RODS Q (ISO MX1)

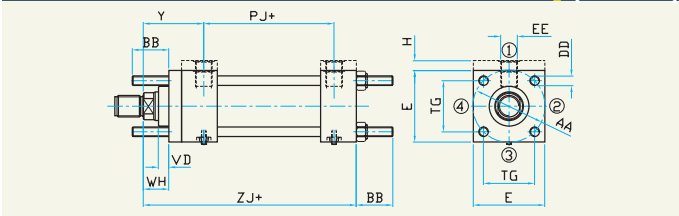

FIJACIÓN POSTERIOR / REAR TAPPED HOLES T (ISO MX6)

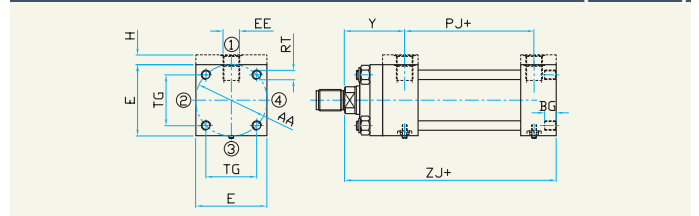

Pistón Piston	Vástago Rod		AA	BB	BD	BG	CB	CD	CF	CX	DD	E	EE	EP	EX	F	FB	G	GA	H	JA	
25	12	18	40	19	20	12	16(*)	10	40	12	M5x0.8	40	G1/4	9	10	10	5.5	32	—	5	32	
32	14	18	22	47	24	25	15	16	12	45	16	M6x1	45	G1/4	12	14	10	6.6	35.5	—	5	35.5
40	18	22	28	59	35	29	16	20	14	60	20	M8x1	60	G3/8	14	16	10	11	46	—	—	46
50	22	28	36	74	46	38	18	30	20	74	25	M12x1.25	75	G1/2	18	20	16	14	45	—	—	45
63	28	36	45	91	46	48	18	30	20	90	30	M12x1.25	90	G1/2	20	22	16	14	45	—	—	45
80	36	45	56	117	59	58	24	40	28	110	40	M16x1.5	115	G3/4	24	28	20	18	52	—	—	52
100	45	56	70	137	59	68	24	50	36	130	50	M16x1.5	130	G3/4	30	35	22	18	55	—	—	55
125	56	70	90	178	81	88	30	64(*)	45	164	60	M22x1.5	165	G1	38	44	22	22	65	87	—	65
160	70	90	110	219	92	108	35	80(*)	56	200	80	M27x2	200	G1	47	55	25	26	70	95	—	70
200	90	110	140	269	115	125	40	80	70	240	100	M30x2	245	G1 1/4	58	70	25	33	92	117	—	92

Pistón Piston	KB	L	LH H10	LT	MR	MS	PJ	R	RD f8	RT	SB	SS	ST	TC	TD f8	TG	TM	TO	TS	UM
25	7	13	19	16	12	20	49+ (*)	27	38	M5	6.6	73	8.5	38	12	28.3	48	51	54	68
32	10	19	22	20	11	25	47+ (*)	33	42	M6	9	73	12.5	44	16	33.2	55	58	63	79
40	13	19	31	25	16	30	58+ (*)	41	62	M8	11	98	12.5	63	20	41.7	76	87	83	108
50	17	32	37	31	18	35	62+ (*)	52	74	M12	14	92	19	76	25	52.3	89	105	102	129
63	17	32	44	38	18	40	64+ (*)	65	88 (**)	M12	18	86	26	89	32	64.3	100	117	124	150
80	23	39	57	48	31	55	77+ (*)	83	105 (**)	M16	18	105	26	114	40	82.7	127	149	149	191
100	23	54	63	58	46	65	78+ (*)	97	125 (**)	M16	26	102	32	127	50	96.9	140	162	172	220
125	30	57	82	72	43	90	117	126	150 (**)	M22	26	131	32	165	63	125.9	178	208	210	278
160	35	63	101	92	57	100	130	155	170 (**)	M27	33	130	38	203	80	154.9	215	253	260	341
200	37	82	122	116	68	135	165	190	210 (**)	M30	39	172	44	241	100	190.2	279	300	311	439

Pistón Piston	UO	US	UT	UW	VD	WF	WH	XB f9	XC	XG	XJ*	XO	XS	XV MIN	XV MAX	Y	ZJ	ZL	(1)	(2)	(3)
25	65	72	58	45	6	25	15	30	127+	44	95+	130	33	67	72+	45 (*)	114+	114+	10	5	1000
32	70	84	68	50	12	35	25	34	147+	54	109+	148	45	83	80+	58 (*)	128+	128+	10	9	1200
40	110	103	95	70	12	35	25	42	172+	57	131+	178	45	96	92+	65 (*)	153+	153+	15	20	1500
50	130	127	116	90	9	41	25	50	191+	64	136+	190	54	106	94+	69 (*)	159+	159+	20	70	1800
63	145	161	139	100	13	48	32	60	200+	70	146+	206	65	118	98+	76 (*)	168+	168+	30	70	2300
80	180	186	178	130	9	51	31	72	229+	76	165+	238	68	133	108+	82 (*)	190+	190+	35	160	3000
100	200	216	207	140	10	57	35	88	257+	71	177+	261	79	147	113+	91 (*)	203+	203+	45	160	3500
125	250	254	265	180	10	57	35	—	289+	75	214+	304	79	166	123+	86	232+	254+	60	460	3500
160	300	318	329	215	7	57	32	—	308+	75	227+	337	86	182	120+	86	245+	270+	70	820	3500
200	360	381	401	300	7	57	32	—	381+	85	271+	415	92	213	142+	98	299+	324+	80	1150	3500

(*) No cumple la norma ISO 6020/2 - 1991
Don't comply with ISO 6020/2 - 1991

(**) Cota "RD" unificada para diámetros superiores
cumple la norma ISO 6020/2
"RD" rate unified to the higher diameter complying
with ISO 6020/2

(1) Carrera mínima para ejecuciones H (ISO MT4)
Minimum stroke for H mounting (ISO MT4)

(2) Valor de tensión de tirantes (Nm)
Tightening torque tie-rods value (in Nm)

(3) Para carreras superiores se aconseja la versión con contrabridas (consultar nuestro despacho técnico)
For higher strokes, a version with counterflanges is available (contact our technical department)

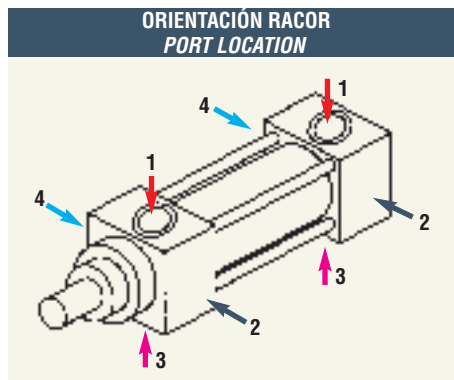

ENTRADAS ACEITE
OVERSIZE OIL PORT

Tipo Type	Camisa Bore	Delantera Front	Trasera Rear
CD	25	—	G 3/8"
	32	—	G 3/8"
	40	—	G 1/2"
	50	—	G 3/4"
	63	—	G 3/4"
	80	—	G 1"
100	—	G 1"	
DK	125	G 1 1/4"	G 1 1/4"
	160	G 1 1/4"	G 1 1/4"
	200	G 1 1/2"	G 1 1/2"

VERSIÓN CON CONTRABRIDAS
VERSION WITH COUNTERFLANGES **CC**

Aconsejada en las carreras largas
(consultar nuestro despacho técnico)
Recommended for long strokes
(contact our technical department)

CILINDRO BASE / FRONT TAPPED HOLES **X**

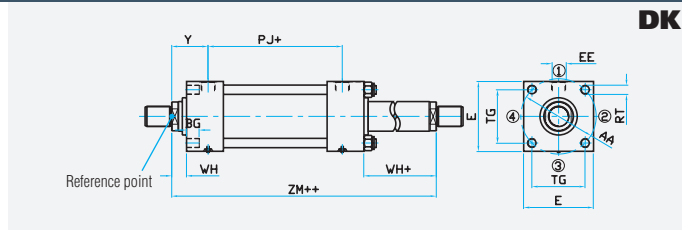
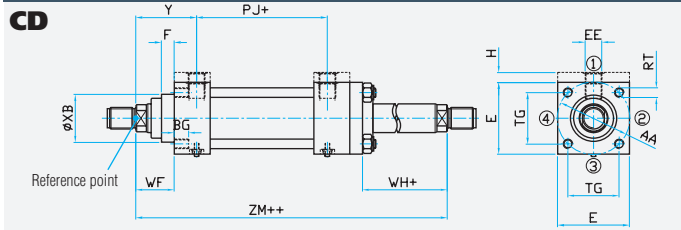

BRIDA DELANTERA / FRONT FLANGE **A**

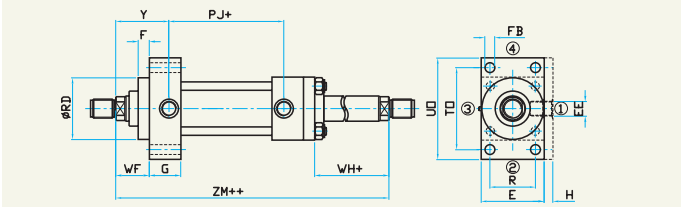

PATAS / FEET **E**

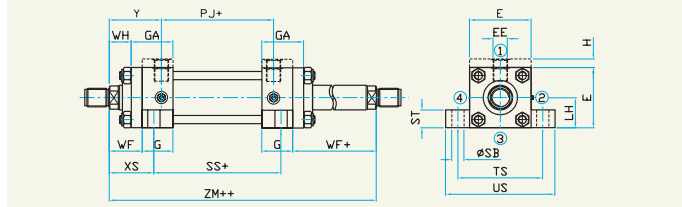

MUÑO DELANTERO / FRONT TRUNNIONS **G**

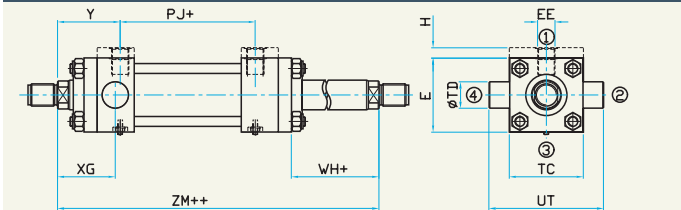

MUÑO INTERMEDIO / INTERMEDIATE TRUNNIONS **H**

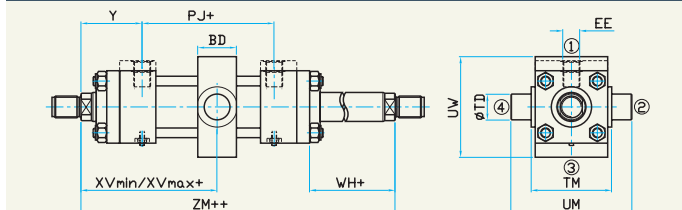

TIRANTES PROL. AMBOS LADOS / FRONT AND REAR EXT. TIE-RODS **Q**

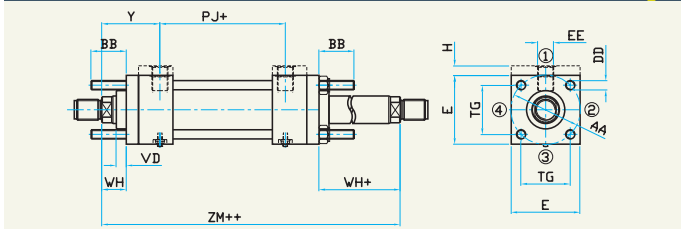

- (1) Carrera mínima para ejecuciones H (ISO MT4)
Minimum stroke for H mounting (ISO MT4)
- (2) Valor de tensión de tirantes (Nm)
Tightening torque tie-rods value (in Nm)
- (3) Para carreras superiores se aconseja la versión con contrabridas
For higher strokes, a version with counterflanges is available

Pistón Piston	Vástago Rod	AA	BB	BD	BG	DD	E	EE	F	FB	G	GA	H	JA	LH H10	PJ	R	RD f8	RT	SB	SS	ST	
25	12	18	40	19	20	12	M5x0.8	40	G1/4	10	5.5	32	—	5	32	19	49+	27	38	M5	6.6	73	8.5
32	14	18	22	47	24	15	M6x1	45	G1/4	10	6.6	35.5	—	5	35.5	22	47+	33	42	M6	9	73	12.5
40	18	22	28	59	35	18	M8x1	60	G3/8	10	11	46	—	—	46	31	58+	41	62	M8	11	98	12.5
50	22	28	36	74	46	18	M12x1.25	75	G1/2	16	14	45	—	—	45	38	62+	52	74	M12	14	92	19
63	28	36	45	91	46	18	M12x1.25	90	G1/2	16	14	45	—	—	45	44	64+	65	88	M12	18	86	26
80	36	45	56	117	59	24	M16x1.5	115	G3/4	20	18	52	—	—	52	57	77+	83	105	M16	18	105	26
100	45	56	70	137	59	24	M16x1.5	130	G3/4	22	18	55	—	—	55	63	78+	97	125	M16	26	102	32
125	56	70	90	178	81	30	M22x1.5	165	G1	22	22	65	87	—	65	82	117	126	150	M22	26	131	32
160	70	90	110	219	92	35	M27x2	200	G1	25	26	70	95	—	70	101	130	155	170	M27	33	130	38
200	90	110	140	269	115	35	M30x2	245	G1 1/4	25	33	92	117	—	92	122	165	190	210	M30	39	172	44

Pistón Piston	TC	TD f8	TG	TM	TO	TS	UM	UO	US	UT	UW	VD	WF	WH	XB f9	XG	XS	XV MIN	XV MAX	Y	ZM	(1)	(2)	(3)
25	38	12	28.3	48	51	54	68	65	72	58	45	6	25	15	30	44	33	67	72+	45	139++	10	5	1000
32	44	16	33.2	55	58	63	79	70	84	68	50	12	35	25	34	54	45	83	80+	58	163++	10	9	1200
40	63	20	41.7	76	87	83	108	110	103	95	70	12	35	25	42	57	45	96	92+	65	188++	15	20	1500
50	76	25	52.3	89	105	102	129	130	127	116	90	9	41	25	50	64	54	106	94+	69	200++	20	70	1800
63	89	32	64.3	100	117	124	150	145	161	139	100	13	48	32	60	70	65	118	98+	76	216++	30	70	2300
80	114	40	82.7	127	149	149	191	180	186	178	130	9	51	31	72	76	68	133	108+	82	241++	35	160	3000
100	127	50	96.9	140	162	172	220	200	216	207	140	10	57	35	88	71	79	147	113+	91	260++	45	160	3500
125	165	63	125.9	178	208	210	278	250	254	265	180	10	57	35	—	75	79	166	123+	86	289++	60	460	3500
160	203	80	154.9	215	253	260	341	300	318	329	215	7	57	32	—	75	86	182	120+	86	302++	70	820	3500
200	241	100	190.2	279	300	311	439	360	381	401	300	7	57	32	—	85	92	213	142+	86	356++	80	1150	3500

EXTREMO VÁSTAGO

ROD END

STANDARD

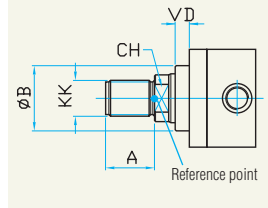

SF

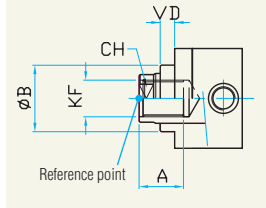

ST

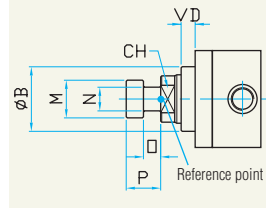

Vástago / Rod	12	14	18	22	28	36	45	56	70	90	110	140
A	14	16	18	22	28	36	45	56	63	85	95	112
B f9	24	26	30	34	42	50	60	72	88	108	133	163
CH	10	12	15	19	22	30	36	46	60	75	95	120
KK	M10x1.25	M12x1.25	M14x1.5	M16x1.5	M20x1.5	M27x2	M33x2	M42x2	M48x2	M64x3	M80x3	M100x3
KF	M8x1	M10x1.25	M12x1.25	M16x1.5	M20x1.5	M27x2	M33x2	M42x2	M48x2	M64x3	M80x3	M100x3
M	11	13	16	18	22	28	35	45	56	70		
N	6.5	8	10	11	14	18	22	28	35	45		
O	5	6	7	8	10	13	16	20	25	35		
P	10	12	14	16	20	25	32	40	50	70		

SL DIN 24554

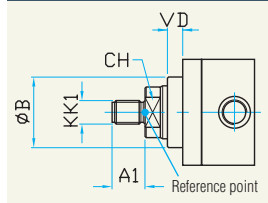

Pistón / Piston	25		32			40			50			63			80			100			125			160			200		
Vástago / Rod	12	18	14	18	22	18	22	28	22	28	36	28	36	45	36	45	56	45	56	70	56	70	90	70	90	110	90	110	140
A1	14		16			18			22			28			36			45			56			63			85		
B f9	24	30	26	30	34	30	34	42	34	42	50	42	50	60	50	60	72	60	72	88	72	88	108	88	108	133	108	133	163
CH	10	15	12	15	19	15	19	22	19	22	30	22	30	36	30	36	46	36	46	60	46	60	75	60	75	95	75	95	120
KK1	M10x1.25		M12x1.25			M14x1.5			M16x1.5			M20x1.5			M27x2			M33x2			M42x2			M48x2			M64x3		
VD	6		12			12			9			13			9			10			10			7			7		

SD DRENAJE GUIA / BUSHING DRAIN

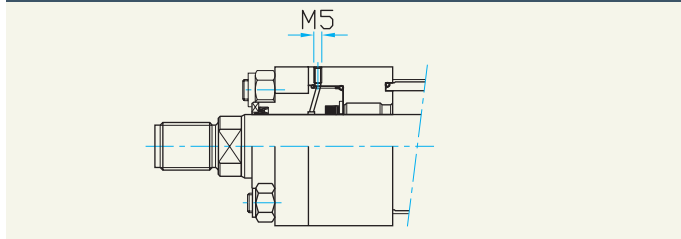

SP SENSORES MAGNÉTICOS / PROXIMITY SWITCHES

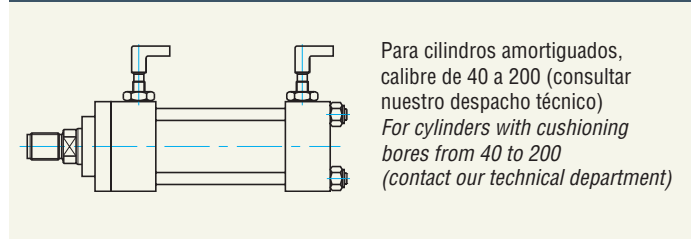

PLACA BASE INCORPORADA / INCORPORATED SUBPLATES

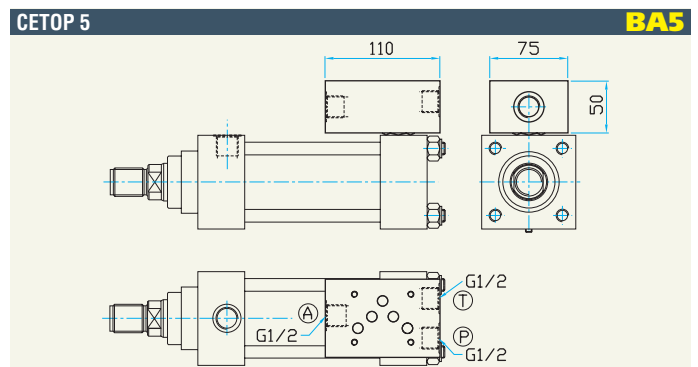
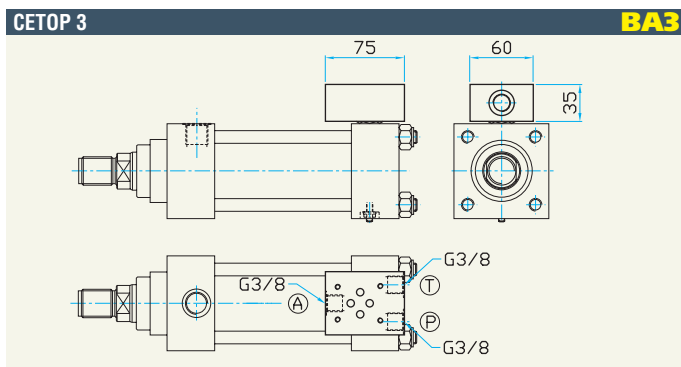

ACCESORIOS VÁSTAGO / ROD ACCESSORIES

CS CABEZA RÓTULA / ROD END EYE WITH SPHERICAL BEARING

ISO 6982

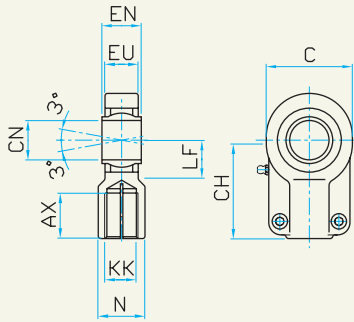

	CS 12125	CS 1415	CS 1615	CS 2015	CS 272	CS 332	CS 422	CS 482	CS 643	CS 803	CS 1003
AX	17	19	23	29	37	46	57	64	86	96	113
C	32	40	47	58	70	89	108	132	168	212	264
CH	38	44	52	65	80	97	120	140	180	210	260
CN	12	16	20	25	32	40	50	63	80	100	125
EN	12	16	20	25	32	40	50	63	80	100	125
EU	10.5	13	17	21	27	32	40	52	66	85	103
KK	M12x1.25	M14x1.5	M16x1.5	M20x1.5	M27x2	M33x2	M42x2	M48x2	M64x3	M80x3	M100x3
LF	14	18	22	27	32	41	50	62	78	98	120
N	16	21	25	30	38	47	58	70	90	110	135
(Kg)	0.11	0.20	0.36	0.62	1.16	2.16	3.84	7.24	13.20	28.0	46.40

TS CABEZA RÓTULA / ROD END EYE WITH SPHERICAL BEARING

DIN 24555

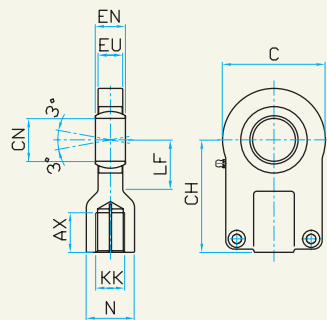

	TS 10125	TS 12125	TS 1415	TS 1615	TS 2015	TS 272	TS 332	TS 422	TS 482	TS 643
AX	15	17	19	23	29	37	46	57	64	86
C	32	42	50	62	76	96	116	150	195	235
CH	42	48	58	68	85	105	130	150	185	240
CN	12	16	20	25	30	40	50	60	80	100
EN	10	14	16	20	22	28	35	44	55	70
EU	8	11	13	17	19	23	30	38	47	57
KK	M10x1.25	M12x1.25	M14x1.5	M16x1.5	M20x1.5	M27x2	M33x2	M42x2	M48x2	M64x3
LF	18	22	28	34	38	48	62	74	98	122
N	17	21	25	30	36	45	55	68	78	100
(Kg)	0.13	0.23	0.39	0.70	1.22	2.14	3.96	7.26	14.60	25.40

CF HORQUILLA CON PERNO / ROD END CLEVIS WITH PIN

ISO 8133

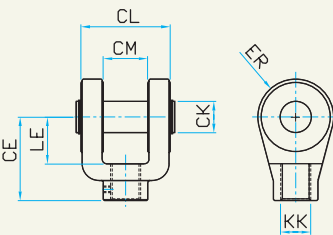

	CF 10125	CF 12125	CF 1415	CF 1615	CF 2015	CF 272	CF 332	CF 422	CF 482	CF 643	CF 803
CE	32	36	38	54	60	75	99	113	126	168	168
CK	10	12	14	20	20	28	36	45	56	70	70
CL	24	32	40	60	60	80	100	120	140	160	160
CM	12	16	20	30	30	40	50	60	70	80	80
ER	12	17	17	29	29	34	50	53	59	78	78
KK	M10x1.25	M12x1.25	M14x1.5	M16x1.5	M20x1.5	M27x2	M33x2	M42x2	M48x2	M64x3	M80x3
LE	13	19	19	32	32	39	54	57	63	83	83
(Kg)	0.10	0.18	0.25	0.88	0.92	1.90	4.92	6.52	10.04	19.50	19.50

ELEMENTOS DE RECAMBIO / SPARE PARTS

CÓDIGO ORDEN PARA JUNTAS DE RECAMBIO
SPARE SEALS ORDERING CODE

R	G	Y	S 28		
Recambio Spare	Juntas Seal	Tipo de juntas Seal type	Vástago Rod (1)	Pistón Piston (2)	
X	Standard	S	12	P	25
Y	Baja fricción / Low friction	S	14	P	32
W	Viton® / Viton®	S	18	P	40
N	Agua-glicol / HFC-fluid	S	22	P	50
		S	28	P	63
		S	36	P	80
		S	45	P	100
		S	56	P	125
		S	70	P	160
		S	90	P	200
		S	110		
		S	140		

CÓD. PEDIDO PARA EL GRUPO REGULACIÓN DE FRENADO
CUSHIONING REGULATION GROUP ORDERING CODE

GF	620
	Para diámetros cilindro: For cylinders with diameter: (3)
620	32-40
625	50-63
630	80-100-125-160
635	200

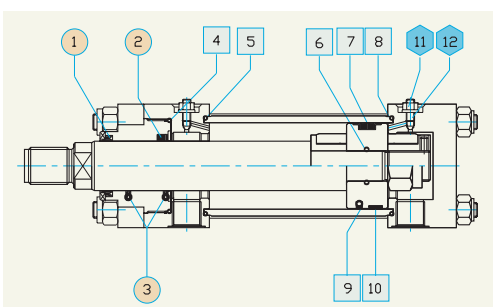

- (1) Serie completa de juntas para el casquillo
Complete series of bushing seals
- (2) Serie completa de juntas para el pistón y la camisa del cilindro
Complete series of piston seals and cylinder body seals
- (3) Grupo regulación de frenado
Cushioning adjusting group

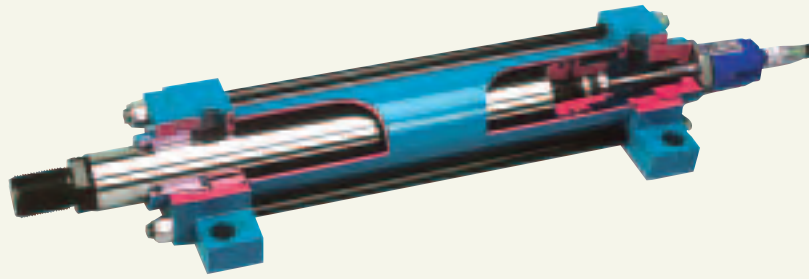

SERVOCILINDROS TIPO M CON TRANSDUCTOR TEMPOSONIC
SERVOCYLINDERS TYPE M WITH TRANSDUCTOR TEMPOSONIC

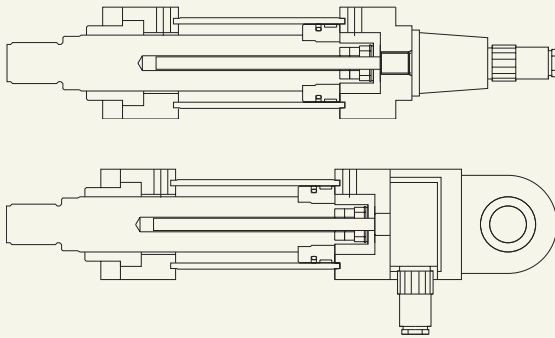

SERVOCILINDROS TIPO P CON TRANSDUCTOR POTENCIOMÉTRICO
SERVOCYLINDERS TYPE P WITH TRANSDUCTOR POTENTIOMETRIC

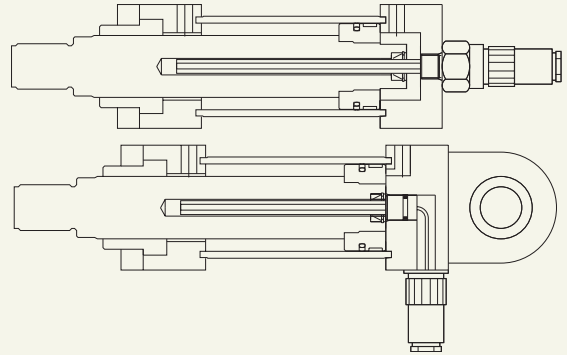

CARACTERÍSTICAS TÉCNICAS / SPECIFICATIONS

Código Code	Tipo transductor Transducer type	Salida Output	Alimentación Supply voltage	Resolución Resolution	Lineabilidad Linearity	Ripetibilidad Repeatability	Histeresis Hysteresis	Absorción Absorption	Veloc. máx Max speed	Temperatura Temperature	Carrera máx Max stroke
MV	Temposonic	0-10 V	24V DC	Infinito Endless	$\leq \pm 0.05\%$ F.S. min ± 0.05 mm	$\leq \pm 0.01\%$ F.S. min ± 0.0025 mm	$\leq \pm 0.02$ mm	80 mA	2 m/s	-20 +65 °C	2000 mm
MA	Temposonic	4-20 mA	24V DC	Infinito Endless	$\leq \pm 0.05\%$ F.S. min ± 0.05 mm	$\leq \pm 0.01\%$ F.S. min ± 0.0025 mm	$\leq \pm 0.02$ mm	80 mA	2 m/s	-20 +65 °C	2000 mm
MS	Temposonic	SSI (Synchronic Serial Interface)	24V DC	0.005 mm	$\leq \pm 0.02\%$ F.S. min ± 0.05 mm	$\leq \pm 0.01\%$ F.S. min ± 0.0025 mm		70 mA	2 m/s	-20 +65 °C	2000 mm
PV	Potenciómetro Potentiometer		Voltaje máx. 60V Max voltage 60V	Infinito Endless	-0.001				1 m/s	-20 +70 °C	500 mm

Dimensión cilindro (consultar la página 7) / Cylinder dimensions (see page 7)

DESIGNACION DE CODIGOS / ORDERING CODE

TD		MV		50 / 36		A		500		Y			
Serie Type	TD	Trasductor Transducer	MV	Camisa / Vástago Bore / Rod		Fijación Mounting		Carrera Stroke	Juntas Seals		Extremo vástago Rod extremities		Otras opciones Other options
	TK		MA	MS	PV				Y	W	SF	ST	
				40	28	Cilindro base Front tapped holes	MX5	X		Baja fricción Low friction	Rosca macho Male thread	standard	Cons. pág. 5 See page 5
				50	36	Brida delantera Flange	ME5	A		Viton® Viton®	Rosca hembra Female thread		
				63	36	Patas Feet	MS2	E			Tenón Tenon		
				45		Muñón delantero Front trunnions	MT1	G			Rosca macho - DIN 24554 Male thread - DIN 24554		
				80	45	Muñón intermedio Intermediate trunnions	MT4	H					
				56		Muñón trasero Rear trunnions	MT2	L					
				100	56	Tirantes delanteros prolon. Extended front tie-rods	MX3	R					
				56									
				125	70	Charnela rotula Ball jointed eye	MP5	D					
				90		Charnela hembra Female clavis	MP1	M					
				TK	160	Brida trasera Rear flange	MF6	B					
				90		Fijación posterior Rear tapped holes	MX6	T					
				200	110								
				140									

Consultar nuestro despacho técnico
Contact our technical department

SENSORES MAGNÉTICOS PARA CILINDRO "MD" / MAGNETIC PROXIMITY SWITCH FOR "MD" CYLINDERS

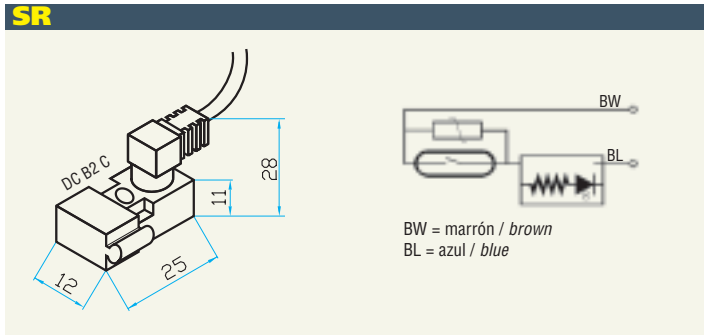

CARACTERÍSTICAS TÉCNICAS / SPECIFICATIONS **SR**

Voltaje / Voltage	24-110 V AC/DC
Corriente máxima / Max current (a 25 °C)	0.3 A
Circuito eléctrico / Electric circuit	REED
Grado de potencia / Protection class	IP 67 EN60529
Temperatura ambiente / Temperature range °C	-20 +80
Indicación / Indicating	LED
Cable / Cable	mm ² 2x0.25
Longitud cable / Cable length	mt 5.0

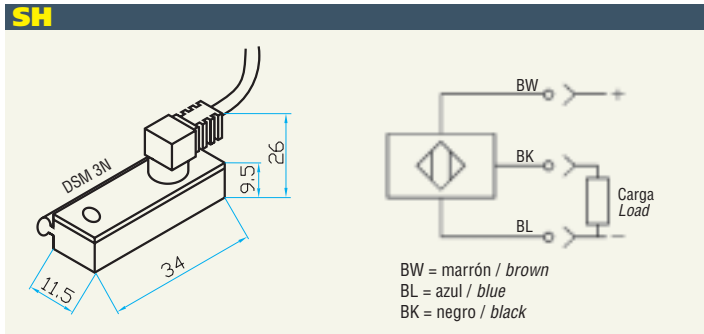

CARACTERÍSTICAS TÉCNICAS / SPECIFICATIONS **SH**

Voltaje / Voltage	24 V DC
Corriente máxima / Max current (a 25 °C)	0.25 A
Circuito eléctrico / Electric circuit	PNP
Grado de potencia / Protection class	IP 67 EN60529
Temperatura ambiente / Temperature range °C	-20 +80
Indicación / Indicating	LED
Cable / Cable	mm ² 3x0.25
Longitud cable / Cable length	mt 5.0

ABRAZADERAS PARA CILINDROS "MD" / BRACKET FOR "MD" CYLINDERS

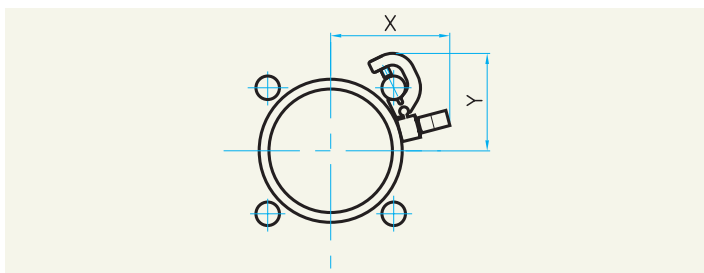
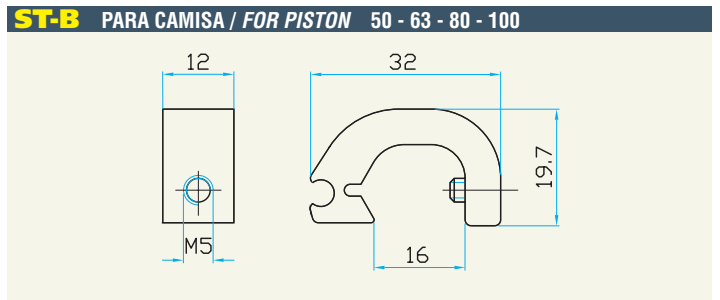
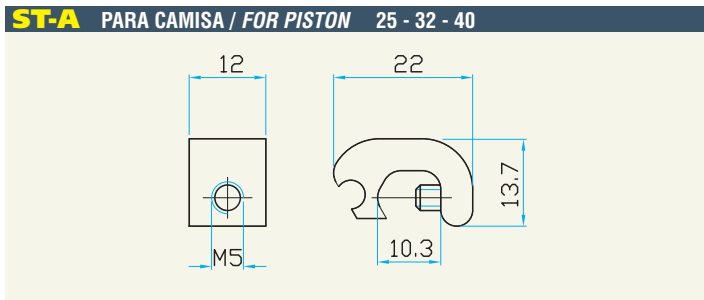

Camisa / Piston	X	Y	Abrazadera / Bracket
25	43	26	ST-A
32	45	28	
40	50	32	
50	56	44	ST-B
63	61	50	
80	71	57	
100	78	64	

CÓDIGO PEDIDO PARA SENSOR Y ABRAZADERA / SWITCH + BRACKET ORDERING CODE

	SR	A	
Tipo / Type	Sensore / Switch	Abrazadera / Bracket	Para diámetros cilindro / For cylinder bore
REED	SR	A	25-32-40
PNP	SH	B	50-63-80-100

HR

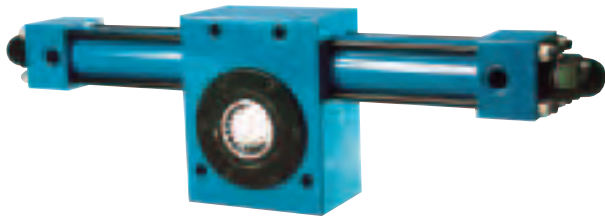

MR

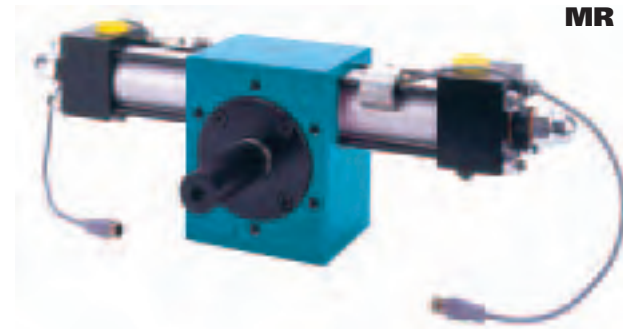

CARACTERÍSTICAS TÉCNICAS / SPECIFICATIONS

		HR 32/32	HR 40/70	HR 63/96
Camisa Bore		32	40	63
Carrera específica Specific stroke	(1)	0.28	0.61	0.83
Tensión específica Specific torque	da Nm/bar	0.12	0.40	1.20
Presión de operación Operating pressure	bar	100	100	100
Presión máxima Peak pressure	bar	140	140	140
Velocidad máx. de rotación Max. speed rotation	rad/sec	30	14	10
Peso Weight	(180°) Kg	4.80	12.5	43

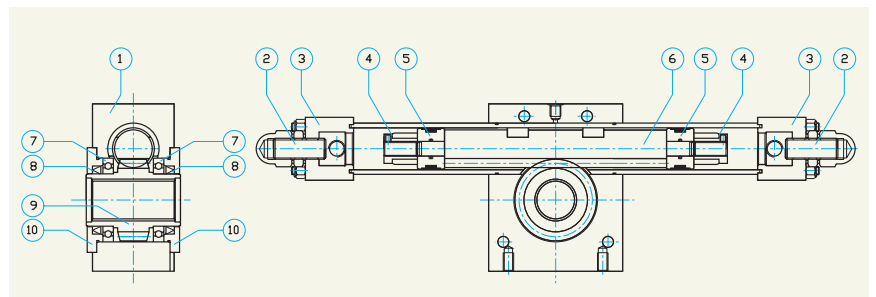

Otras características, como los cilindros CD y MD (consultar pág. 3) / Other features such as CD and MD cylinders (see page 3).

(1) Carrera específica para cada ángulo de rotación. Por ejemplo HR 40/70-180° carrera (0,61x180)=110. / Specific stroke for every rotation angle. For example HR 40/70-180° stroke (0.61x180)=110.

HR 32/32

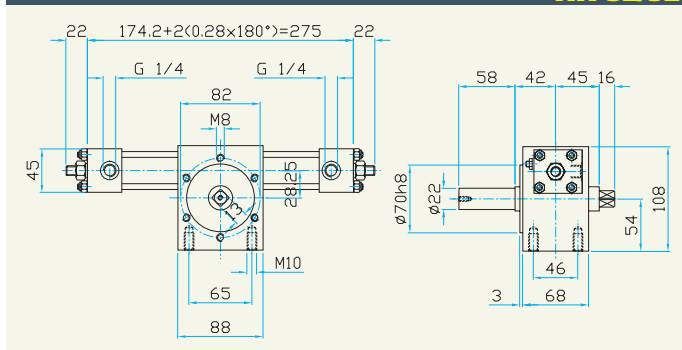

Ref. / Ref.	DESCRIPCIÓN / DESCRIPTION
1	Cuerpo / Body
2	Ajustador de carrera +/-5° / Stroke adjuster +/-5°
3	Tapa / End cap
4	Amortiguación / Cushioning
5	Pistón / Piston
6	Cremallera / Rack-rail
7	Cojinete / Ball bearing
8	Rodamientos / Rotating tightness
9	Rueda dentada / Toothed wheel
10	Brida trasera / Closing flange

HR 40/70

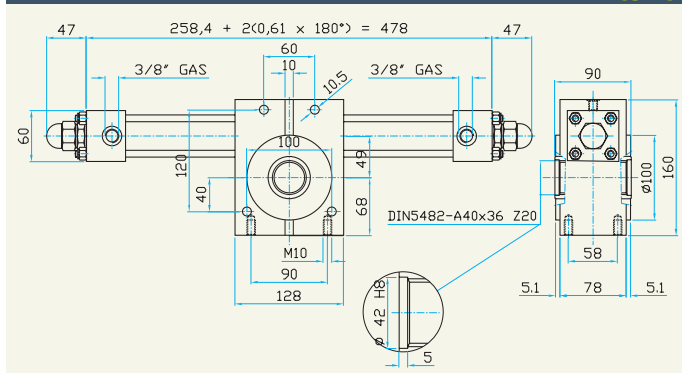

HR 63/96

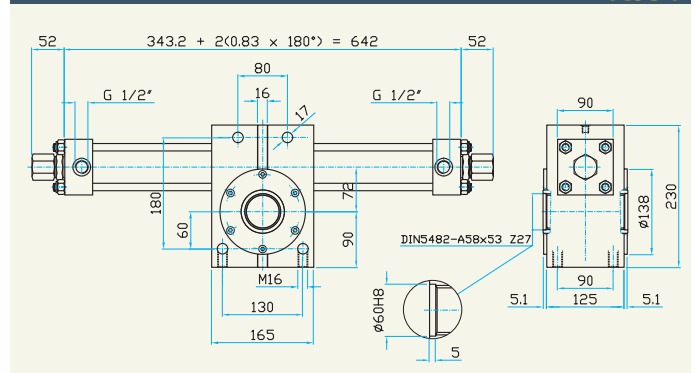

DESIGNACION DE CODIGOS / ORDERING CODE

HR	40 / 70	-	180	K	R		
Serie / Type HR Standard MR Magnético Magnetic	Camisa / Diám. de Piñón Piston / Pinion diameter		Angulo de rotación Angle of rotation			Juntas / Seals	Sensore (solo para cilindros MD) indicar cantidad Switch (only for MR cylinders) specify quantity
	32 / 32		Standard 180°			Standard	SR REED 24-110 V. AC/DC
	40 / 70		(A demandar otro ángulo) Max 270° (Other angle on demand)			Y Baja fricción / Low friction	SH PNP 24 V. DC
	63 / 96		Consultar nuestro despacho técnico Contact our technical department			W Viton®	(consultar pág. 12 / see page 12)
						N Agua-glicol / HFC-fluid	

Cilindros hidráulicos de doble efecto, de construcción robusta y compacta, con interruptores magnéticos incorporados. Diseñados para automatización industrial.

Double-acting hydraulic cylinders, strong and compact construction, with built-in proximity switches. Designed for use in industrial automation.

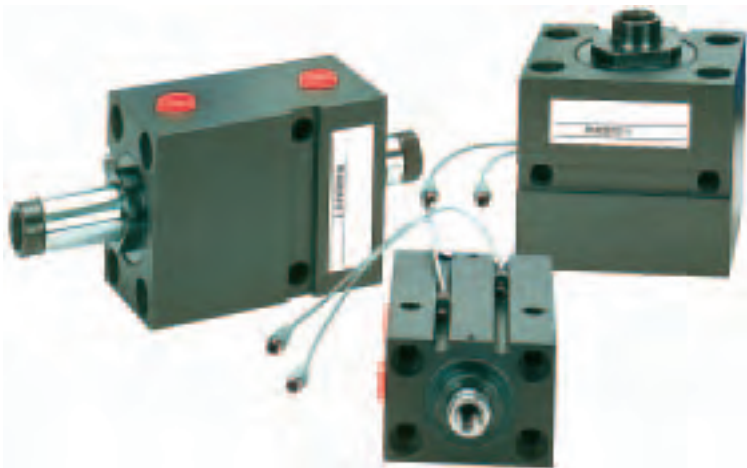

CARACTERÍSTICAS TÉCNICAS / SPECIFICATIONS

Presion máxima Max pressure	bar	160	
Temperatura fluido Fluid temperature	°C	Standard -20 +80	Viton® W -20 +150
Carrera Stroke	mm	20, 50	A demandar otra carrera Other strokes on demand
Fluido Fluid		Aceite hidráulico mineral - Ester fosfórico Hydraulic mineral oil - Phosphoric esters	
Fijacion Mounting		Delantera, trasera, lateral Front, rear, lateral	

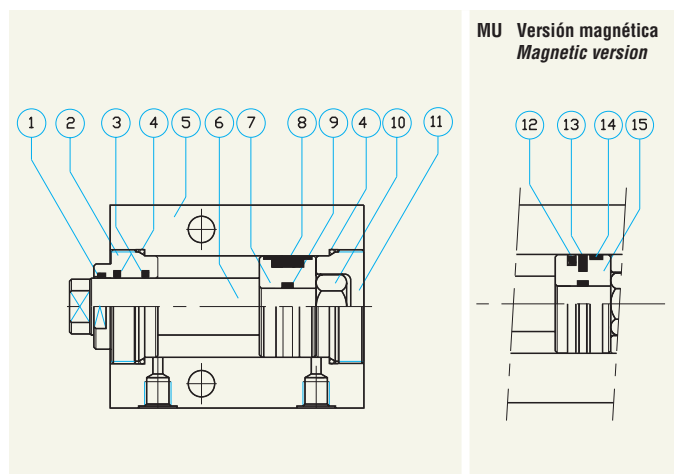

Ref. Ref.	Componentes Component	Material Material
1	Rascador / Wiper	Goma nitrilo + PTFE / Nitrile rubber + PTFE
2	Guia vástago / Guide bushing	Bronce / Bronze
3	Junta de vástago / Rod seals	Goma nitrilo + PTFE / Nitrile rubber + PTFE
4	Junta OR + BK / O-Ring seal + BK	Goma nitrilo + PTFE / Nitrile rubber + PTFE
5	Cuerpo / Cylinder body	Aleacion ligera / Special light alloy
6	Vástago / Rod	Acero cromado / Chrome-plated steel
7	Pistón (RU) / Piston (RU)	Acero / Steel
8	Junta pistón (RU) / Piston seal (RU)	NBR/Acetal/POM / NBR/Acetal/POM
9	Junta OR / O-Ring seal	Goma nitrilo / Nitrile rubber
10	Tuerca vástago / Rod nut	Acero / Steel
11	Tapón posterior / Rear plug	Acero / Steel
12	Junta pistón (MU) / Piston seal (MU)	Goma nitrilo + PTFE / Nitrile rubber + PTFE
13	Magneto / Magnet	
14	Pattini antifrizione / Low-friction bearings	Resina de fenol / Phenolic
15	Pistón magnético (MU) / Magnetic piston (MU)	AISI

VERSIÓN BÁSICA / BASIC VERSION

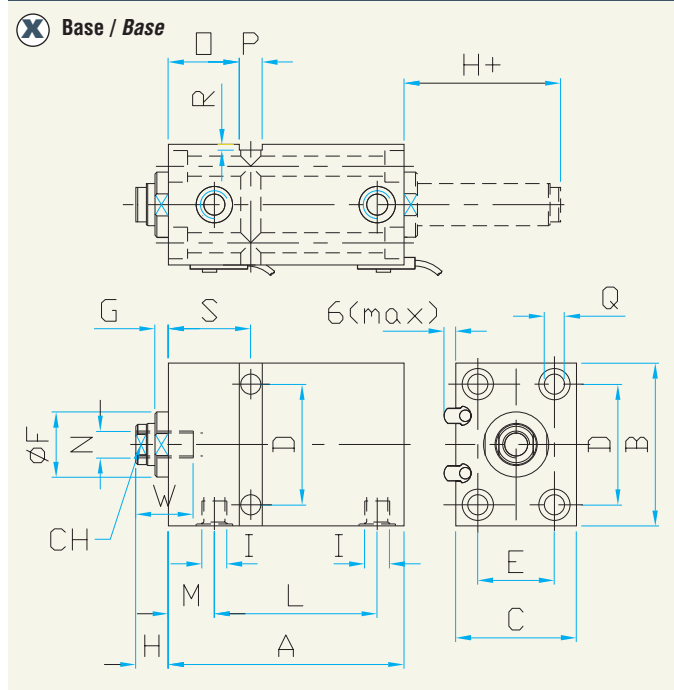

Pistón Piston	25		32		40		50		63		80		100			
	18	22	22	28	28	36	45									
Vástago Rod	20		50		20		50		20		50		20		50	
A	77	107	80	110	93	123	95	125	105	135	120	150	130	160		
B	65	75	85	100	115	140	170									
C	45	55	63	75	90	110	140									
CH	15	19	19	22	22	30	36									
D	50	55	63	76	90	110	135									
E	30	35	40	45	55	75	95									
F f8	32	34	34	42	50	60	72									
G	6.5	8	7	8	7	7	8									
H	14	15	17	20	20	20	25									
I	G1/4	G1/4	G1/4	G1/4	G3/8	G1/2	G1/2									
L	43	73	44	74	46	76	48	78	53	83	60	90	60	90		
M	17	18	23.5	23.5	26	30	35									
N	M10	M12	M14	M20	M20	M27	M33									
O	32	34	37	37.5	47.5	50	60									
P	10	12	12	15	15	20	20									
Q	8.5	10.5	10.5	13	13	17	17									
R	2	3	3	5	5	5	5									
S	37	40	43	45	55	60	70									
W	23	23	30	30	30	40	50									

VERSIÓN ALIMENTACIÓN ACEITE / OIL FEEDER VERSION

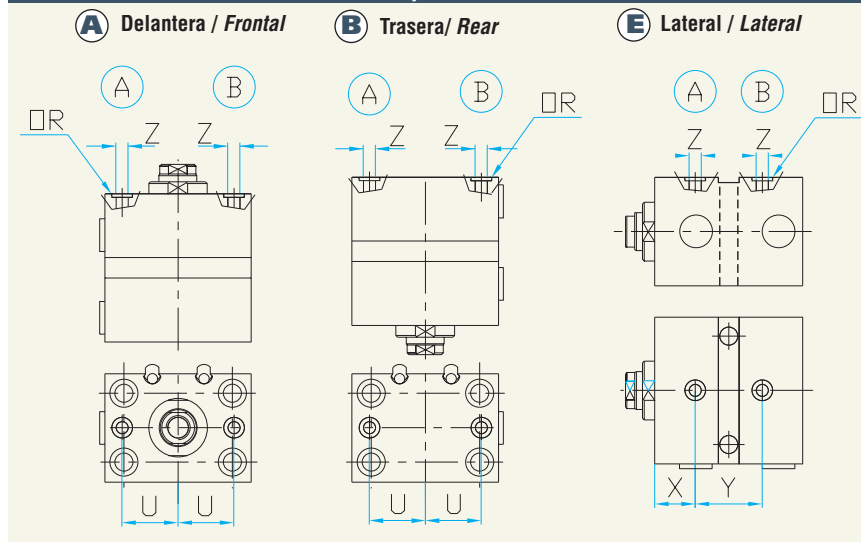

Pistón / Piston	U	X	Y	Z	OR
25	25.5	17	23+	4	OR 106(610)
32	30	18	24+	4	OR 106(610)
40	32.5	23.5	26+	5	OR 106(610)
50	40	23.5	28+	7	OR 108(611)
63	47.5	26	33+	7	OR 108(611)
80	59	30	40+	7	OR 108(611)
100	70	35	40+	7	OR 108(611)

ACCESORIO VÁSTAGO / ROD ACCESSORIES

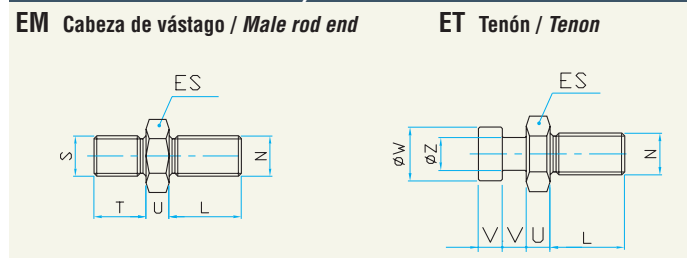

Tipo / Type		Dimensión / Dimension									
ES	L	N	S	T	U	V	W	Z			
EM10	ET10	17	20	M10	M10x1.25	14	6	7	16	10	
EM12	ET12	19	20	M12	M12x1.25	16	7	8	18	11	
EM14	ET14	22	25	M14	M14x1.5	18	8	8	18	11	
EM20	ET20	30	30	M20	M20x1.5	28	9	10	22	14	
EM27	ET27	36	40	M27	M27x2	36	12	12.5	28	18	
EM33	ET33	46	50	M33	M33x2	45	14	16	35	22	

SENSORES MAGNÉTICOS / PROXIMITY SWITCHES

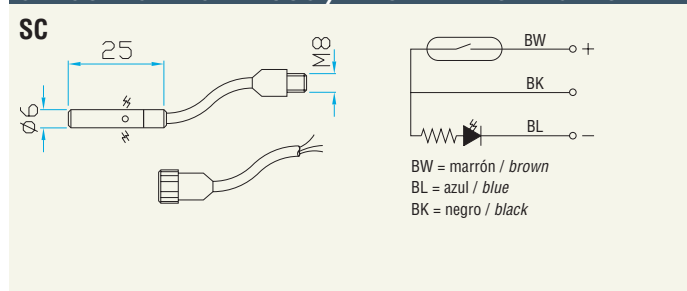

CARACTERÍSTICAS TÉCNICAS / SPECIFICATIONS		SC
Tensión / Voltage		24 V AC/DC
Máx. corriente / Max current (25 °C)		0.25 A
Circuito eléctrico / Electric circuit		REED
Grado de potencia / Protection class		IP 67 EN60529
Temperatura ambiente / Temperature range		-20 +80 °C
Indicación / Indicating		LED
Cable / Cable		3x0.25 mm ²
Longitud / Length		3 mt

ST-C Abrazaderas para MU / Bracket for MU

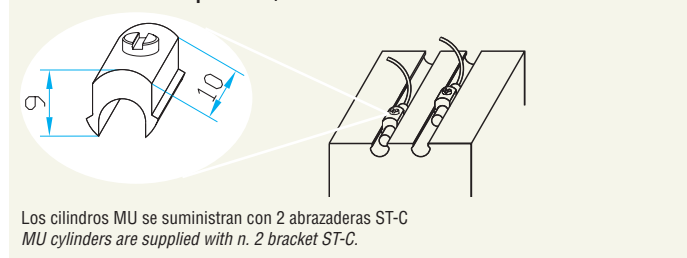

USO CORRECTO DE LOS SENSORES MAGNÉTICOS
Los valores de la tensión y de la corriente nunca deben superar los valores indicados en la plantilla. Los picos de corriente pueden ser causados por cargas capacitivas (cables de más de 3 metros de largo), o por inductancias (electroválvulas, relevadores, telereductores, etc.).
Las distorsiones magnéticas pueden ser causadas por masas ferrosas (los asientos del cilindro dentro de los moldes) o por la presencia de fuertes campos magnéticos (motores eléctricos, bobinas, etc.).

CORRECT USE OF MAGNETIC SENSORS
Voltage and current values must never exceed values specified in the table. Current surges may be caused by capacitive loads (e.g. cables of lengths over 3 metres). Voltage surges may be caused by inductance (e.g. solenoid valves, relays, contactors, etc.).
Magnetic distortion may be caused by ferrous masses (e.g. cylinder seat inside moulds) or the presence of strong magnetic fields (e.g. electric motors, coils, etc.).

DESIGNACION DE CODIGOS / ORDERING CODE

MU	32 / 22	/	X	20			SC	2
Tipo / Type	Pistón / Vástago / Piston / Rod	Posible 2º vástago / Possible 2º rod	Alimentación aceite / Oil feeder	Carrera / Stroke	Distanciador / Spacer	Juntas / Seals	Sensor / Switch	
RU Standard	25 / 18		X Standard	20 20 mm	(para carreras intermedias) in mm	Standard	SC	n. sensores / n. switch
MU Magnético / Magnetic	32 / 22		A Versión / Versions	50 50 mm	... (for intermediate strokes) in mm	Y Baja fricción / Low friction		(Solo para cilindros MU) / (Only for MU cylinders)
	40 / 22		B	A demandar otra carrera / Other stroke on demand		W Viton®		
	50 / 28		E			N Agua-glicol / HFC-fluid		
	63 / 28							
	80 / 36							
	100 / 45							

DESIGNACION CODIGOS JUNTAS ESTANQUEIDAD / ORDERING CODE FOR SPARE SEALS

Consultar pàg. 10 / See page 10