



TRAMEC

TF 56
TF 63

**RIDUTTORI AD ASSI
ORTOGONALI**

**BEVEL HELICAL
GEARBOXES**

**KEGEL
STIRNRADGETRIEBE**





TF 56

T	n1 = 1400			TF			
	i _n	i _r	n ₂ Rpm	T ₂ Nm	P1 kW	FS'	IEC
56B	8	8.06	174	94	1.80	1.2	56 63 71 80 90
	10	10.17	138	119	1.80	1.0	
	12.5	12.31	114	120	1.50	1.0	
	16	16.11	87	115	1.10	1.0	
	20	20.33	69	99	0.75	1.2	
	25	24.62	57	120	0.75	1.0	
	31.5	30.00	47	107	0.55	1.2	
	40	39.39	36	94	0.37	1.3	
	50	48.00	29	115	0.37	1.1	

T	n1 = 1400			TF			
	i _n	i _r	n ₂ Rpm	T ₂ Nm	P1 kW	FS'	IEC
56C	40	40.28	35	95	0.37	1.2	56 63 71 80 90
	50	50.83	28	119	0.37	1.0	
	63	61.54	23	98	0.25	1.3	
	80	80.56	17	92	0.18	1.3	
	100	101.67	14	116	0.18	1.1	
	125	123.08	11	102	0.13	1.2	
	160	150.00	9	124	0.13	1.0	
	200	196.92	7	112	0.09	1.1	
	250	240.00	6	137	0.09	0.9	

TF 56B

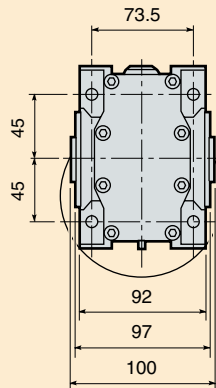
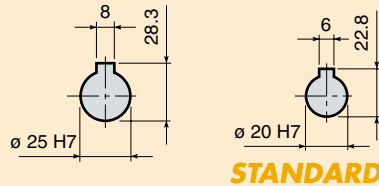
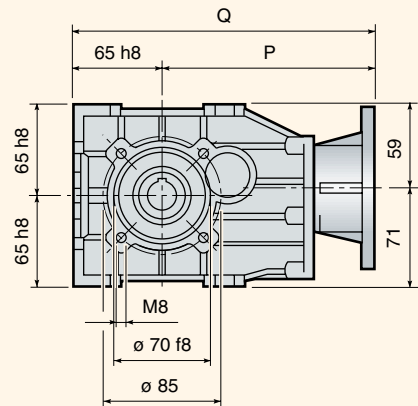
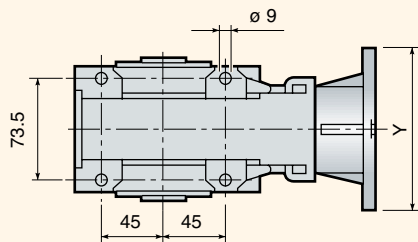

TF 56C

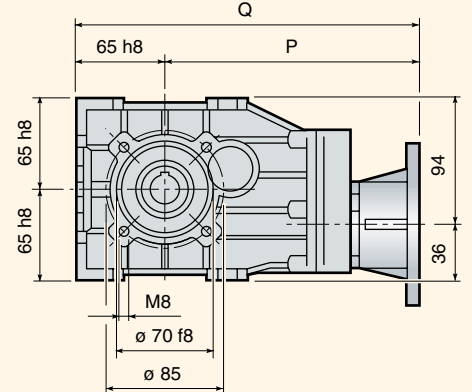
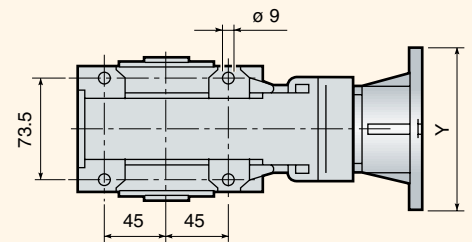

	TF 56B					TF 56C				
IEC	56	63	71	80	90	56	63	71	80	90
Y	120	140	160	180	200	120	140	160	180	200
P	153	156	163	183	183	187	190	197	217	217
Q	218	221	228	248	248	252	255	262	282	282
kg*	4.5	4.5	4.5	4.5	4.5	5.0	5.0	5.0	5.0	5.0

* I riduttori TF 56 e TF 63 sono previsti con lubrificazione a vita e forniti completi di lubrificante sintetico (i pesi sono comprensivi del peso del lubrificante).

* The gearboxes TF56 and TF63 are life-lubricated and are delivered with synthetic lubricant (the a.m. weights include the weight of the lubricant).

* Die Getriebe TF56 und TF63 verfügen über eine Lebensdauerschmierung und werden vor der Lieferung mit synthetischem Schmiermittel gefüllt (die angegebenen Gewichte entsprechen dem mit Öl gefüllten Getriebe).

TF 63

T	n1 = 1400			TF			
	i _n	i _r	n ₂ Rpm	T ₂ Nm	P1 kW	FS'	IEC
63B	8	7.94	176	93	1.80	1.8	63 71 80 90
	10	10.18	138	119	1.80	1.5	
	12.5	12.50	112	146	1.80	1.3	
	16	15.88	88	154	1.50	1.1	
	20	20.36	69	145	1.10	1.2	
	25	25.00	56	178	1.10	1.0	
	31.5	31.00	45	151	0.75	1.2	
	40	40.00	35	194	0.75	1.0	
	50	49.60	28	177	0.55	1.1	
	63	60.80	23	146	0.37	1.0	

T	n1 = 1400			TF			
	i _n	i _r	n ₂ Rpm	T ₂ Nm	P1 kW	FS'	IEC
63C	40	39.71	35	142	0.55	1.2	63 71 80 90
	50	50.89	28	181	0.55	1.0	
	63	62.50	22	150	0.37	1.2	
	80	79.41	18	129	0.25	1.3	
	100	101.79	14	165	0.25	1.1	
	125	125.00	11	146	0.18	1.3	
	160	155.00	9	181	0.18	1.0	
	200	200.00	7	168	0.13	1.1	
	250	248.00	6	205	0.13	0.9	
	315	304.00	5	251	0.13	0.6	

TF 63B

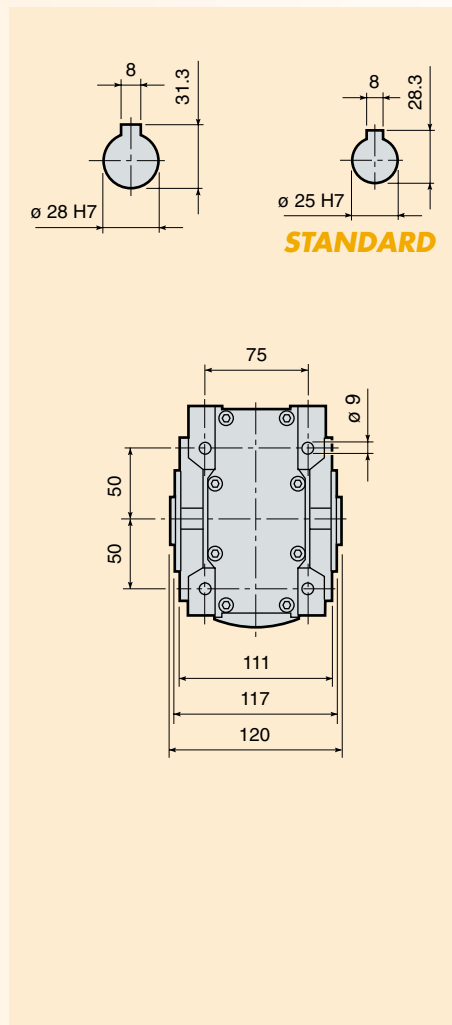
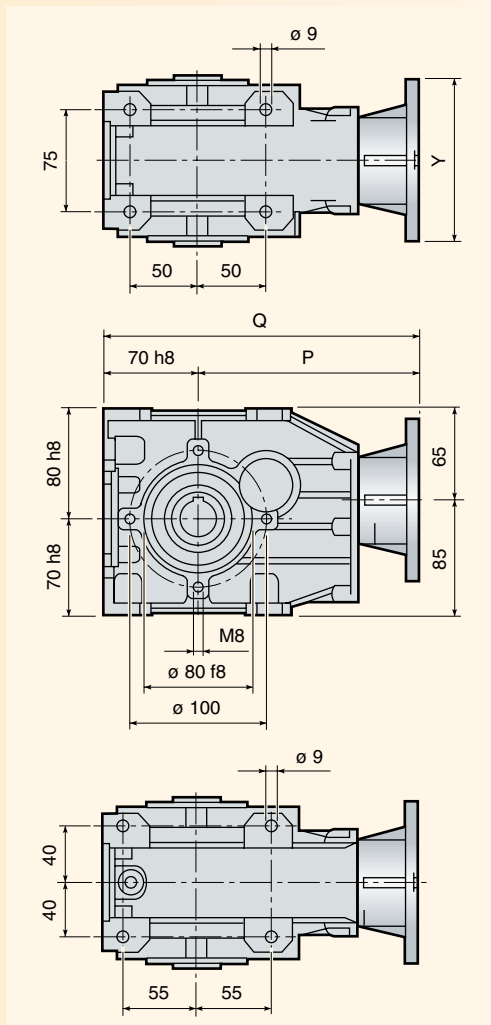

TF 63C

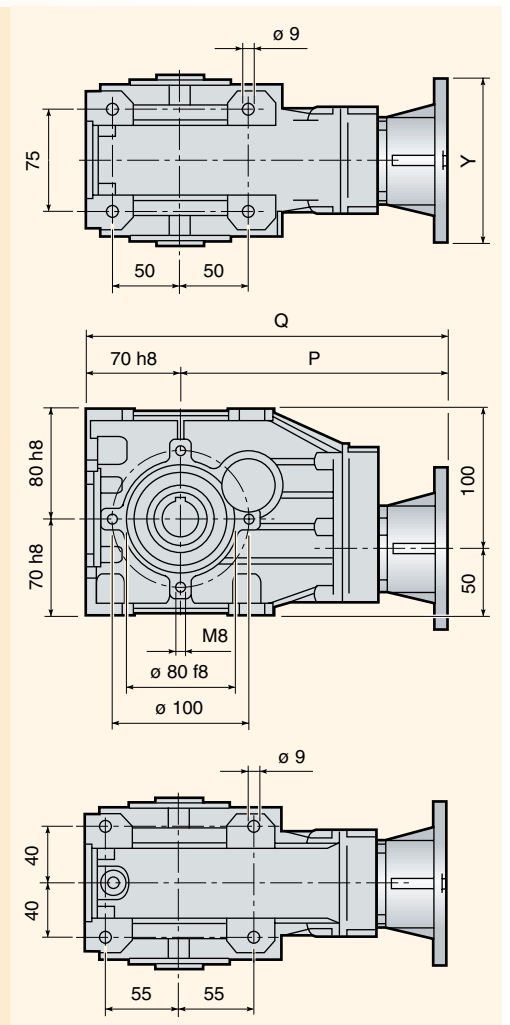

	TF 63B				TF 63C			
IEC	63	71	80	90	63	71	80	90
Y	140	160	180	200	140	160	180	200
P	160	167	187	187	194	201	221	221
Q	230	237	257	257	264	271	291	291
Kg*	6.0	6.0	6.0	6.0	6.5	6.5	6.5	6.5

* I riduttori TF 56 e TF 63 sono previsti con lubrificazione a vita e forniti completi di lubrificante sintetico (i pesi sono comprensivi del peso del lubrificante).

* The gearboxes TF56 and TF63 are life-lubricated and are delivered with synthetic lubricant (the a.m. weights include the weight of the lubricant).

* Die Getriebe TF56 und TF63 verfügen über eine Lebensdauerschmierung und werden vor der Lieferung mit synthetischem Schmiermittel gefüllt (die angegebenen Gewichte entsprechen dem mit Öl gefüllten Getriebe).

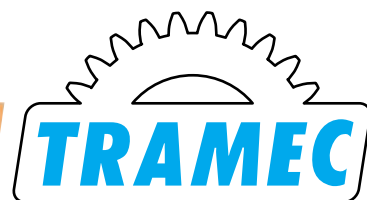

Braccio di Reazione

Torque arm

Drehmomentstütze

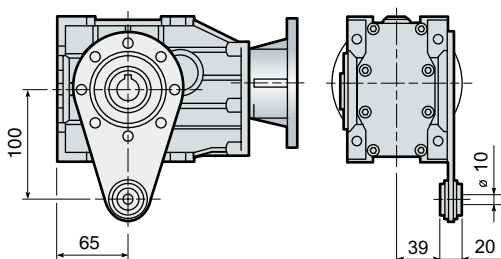

T 56

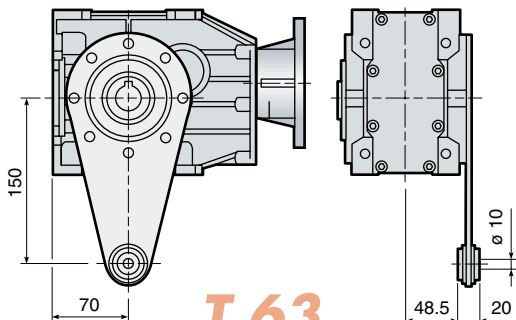

T 63

Albero lento

Output shaft

Abtriebswelle

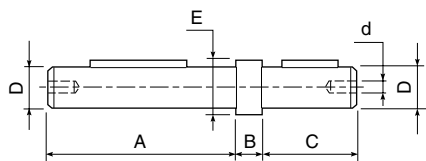

**Albero lento standard
Standard output shaft
Standard Abtriebswelle**

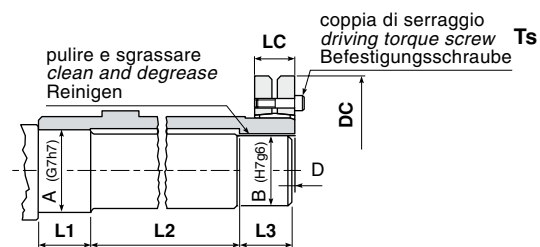

**Albero lento cavo con calettatore
Hollow output shaft with shrink disc
Abtriebs-Hohlwelle mit Schruppscheibe**

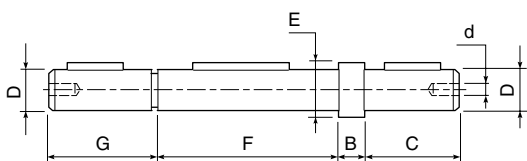

**Albero lento doppio
Double output shaft
Doppelte Abtriebswelle**

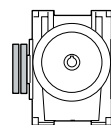

**Calettatore sinistro
Shrink disc left
Schruppscheibe links**

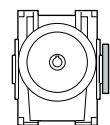

**Calettatore destro
Shrink disc right
Schruppscheibe rechts**

T	A	B	C	D _{g6}	d	E	F	G
T56	100	5	40	20	M8	26	100	41
T63	120	5	45	25	M8	32	120	46

T	A	B	D	DC	LC	L ₁	L ₂	L ₃	Ts (Nm)
T56	27	25	2	60	21.5	32	61	32	4
T63	32	30	2	72	23.5	36	75	36	12

Flangia uscita

Output flange

Abtriebsflansch

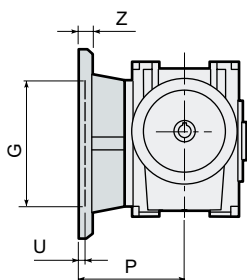

FLS

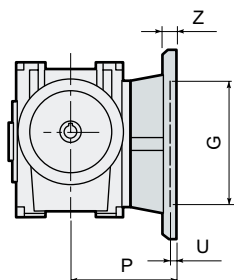

FLD

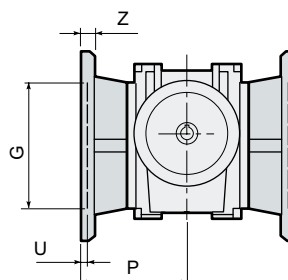

FL2

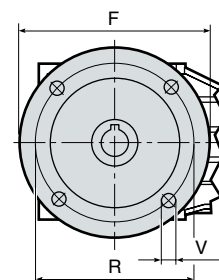

T	F	G _{H7}	R	P	U	V	Z	Kg
T56	140	95	115	82	5	9	15	0.5
T63	160	110	130	91.5	5	9	10	0.5

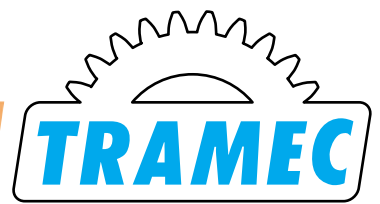

Designazione		Designation		Bezeichnung						
Macchina Machine Maschine	Tipo entrata Input type Antriebsart	Grandezza Size Größe	Rotismo Gearing Getriebe	Rapporto rid. Ratio Untersetzung	Predisposizioni Motor mount. facility Motoranbau	Esecuzione Execution Ausführung	Pos. di montaggio Mounting position Anbauposition	Flangia uscita Output flange Abtriebsflansch	Antiritorno Back-stop device Rücklaufsperr	Calettatore Shrink disk Schrumpfscheibe
T	F	56 63	B 2 rid. 2 Stufen C 3 rid. 3 red. 3 Stufen	10/1 in = .../1 8 - 315	P.A.M. 56 - 90	O Albero entrata orizzontale Horizontal input shaft Antriebswelle horizontal	B3 B6 VA VB	FLS FLD FL2	CW Rotazione oraria Clockwise rotation Im-Uhrzeigersinn AW Rotazione antioraria Anti-Clockwise rotation Gegen den Uhrzeigersinn	C.S. Calettatore sinistro Shrink disc left Schrumpfscheibe links C.D. Calettatore destro Shrink disc right Schrumpfscheibe rechts

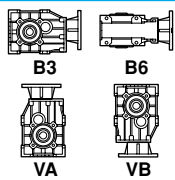
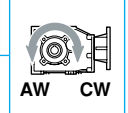
Carichi radiali e assiali (N)

Le trasmissioni effettuate tramite pignoni per catena, ruote dentate o pulegge generano delle forze radiali (F_R) sugli alberi dei riduttori. L'entità di tali forze può essere calcolata con la formula:

$$F_R = \frac{K_R \cdot T}{d} \text{ (N)}$$

dove:

- T = Momento torcente (Nm)
- d = Diametro pignone o puleggia (mm)

- K_R = 2000 per pignone per catena
- = 2500 per ruote dentate
- = 3000 per puleggia con cinghie a V.

I valori dei carichi radiali e assiali generati dall'applicazione debbono essere sempre minori o uguali a quelli ammissibili indicati nelle tabelle.

I carichi radiali indicati nelle tabelle si intendono applicati a metà della sporgenza dell'albero e sono riferiti ai riduttori operanti con fattore di servizio 1.

Radial and axial loads (N)

Transmissions implemented by means of chain pinions, gears or pulleys generate radial forces (F_R) on the gear unit shafts. The entity of these forces may be calculated using this formula:

$$F_R = \frac{K_R \cdot T}{d} \text{ (N)}$$

where:

- T = torque (Nm)
- d = pinion or pulley diameter (mm)

- K_R = 2000 for chain pinion
- = 2500 for gears
- = 3000 for V-belt pulleys.

The value of the radial and axial loads generated by the application must always be less than or equal to the admissible values as indicated in the chart.

The radial loads indicated in the chart are considered to be applied to the half-way point of the projection of the shaft, and refer to gear units operating with service factor 1.

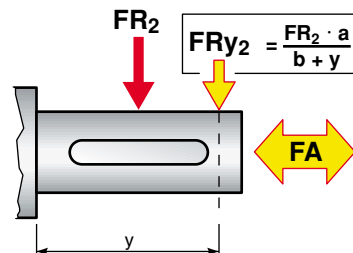

Radial und axial Belastungen (N)

Antriebe mit Kettenrädern, Zahnrädern oder Riemenscheiben erzeugen radiale Kräfte (F_R) an den Wellen der Untersetzungsgetriebe. Das Ausmaß dieser Kräfte kann nach folgender Formel berechnet werden:

$$F_R = \frac{K_R \cdot T}{d} \text{ (N)}$$

dabei ist:

- T = Drehmoment (Nm)
- d = Kettenrad-bzw. Riemenscheibendurchmesser (mm)

- K_R = 2000 bei Kettenrad
- = 2500 bei Zahnrad
- = 3000 bei Riemenscheibe mit Keilriemen

Die Werte der Quer- und Längsbelastungen, die durch die Anwendungen hervorgerufen werden, dürfen nicht über den in den Tabellen angegebenen zulässigen Werten liegen.

Die Querbelastungen, die in den Tabellen angegeben werden gelten für Ansatzpunkte in der Mitte des herausragenden Wellenteils und für Getriebe mit Betriebsfaktor 1.

Albero uscita / Output shaft / Abtriebswelle ($n_1 = 1400 \text{ rpm}$)

n_2	T56B		T63B		n_2	T56C		T63C	
	a=102	b=82	a=117	b=94.5		a=102	b=82	a=117	b=94.5
	Fr_2	Fa_2	Fr_2	Fa_2		Fr_2	Fa_2	Fr_2	Fa_2
8	1300	260	1500	300	40	2300	460	2500	500
10	1300	260	1500	300	50	2300	460	2500	500
12.5	1300	260	1500	300	63	2300	460	2500	500
16	1800	360	2000	400	80	2800	560	3000	600
20	1800	360	2000	400	100	2800	560	3000	600
25	1800	360	2000	400	125	2800	560	3000	600
31.5	1800	360	2000	400	160	2800	560	3000	600
40	2300	460	2500	500	200	3000	600	3500	700
50	2300	460	2500	500	250	3000	600	3500	700
63	-	-	2500	500	315	-	-	3500	700

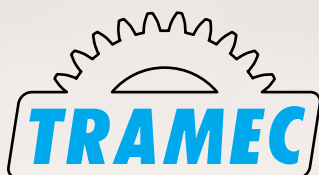

TRAMEC s.r.l. Via Bizzarri, 6 - 40012 Calderara di Reno (BO) Italy - Tel. +39 051728935 - Fax +39 051728937
<http://www.tramec.it> - E-mail: tramec@tramec.it