

SALES FORCE INFORMATION FILE

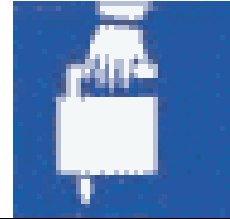

Feet / Ves Assembly for CN211Sp and Sm



Sept. 2001 - Version 2

ACCESSORY

File N°99041ANG

MAIN FUNCTION

 *To manually place a CN211S marking head in position on a flat or circular surface(tubes) .*

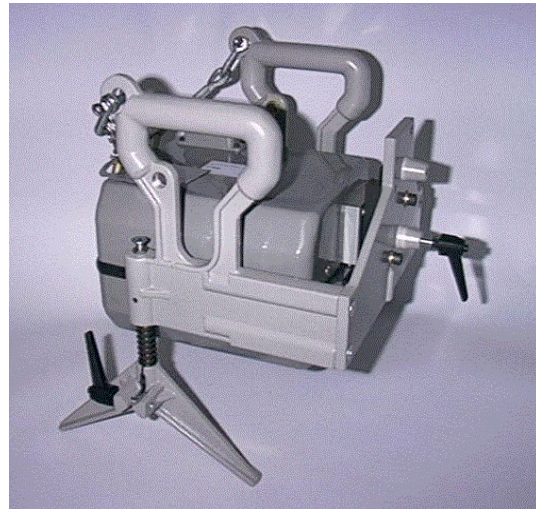
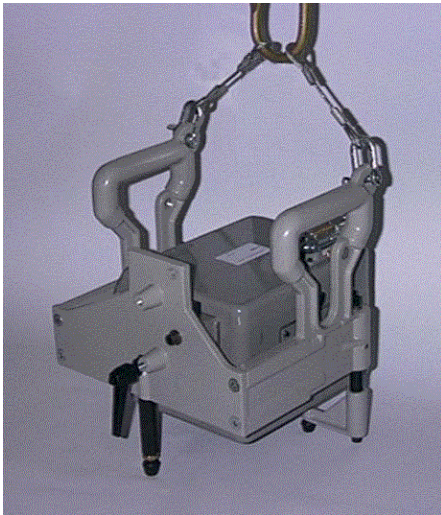

VERSATILITY

- The hand held system is designed to receive **3 feet or 2 ves** in position according to the type of surface to be marked.
- **The addition of a dove-tail** on the hand-held unit allows **the head to be placed in position fast and easily**, particularly in the case of use on several work supports .

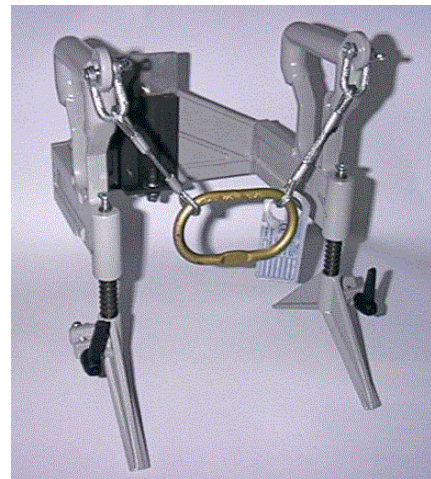

DIMENSIONAL PLAN

HEAD CN211Sp + feet

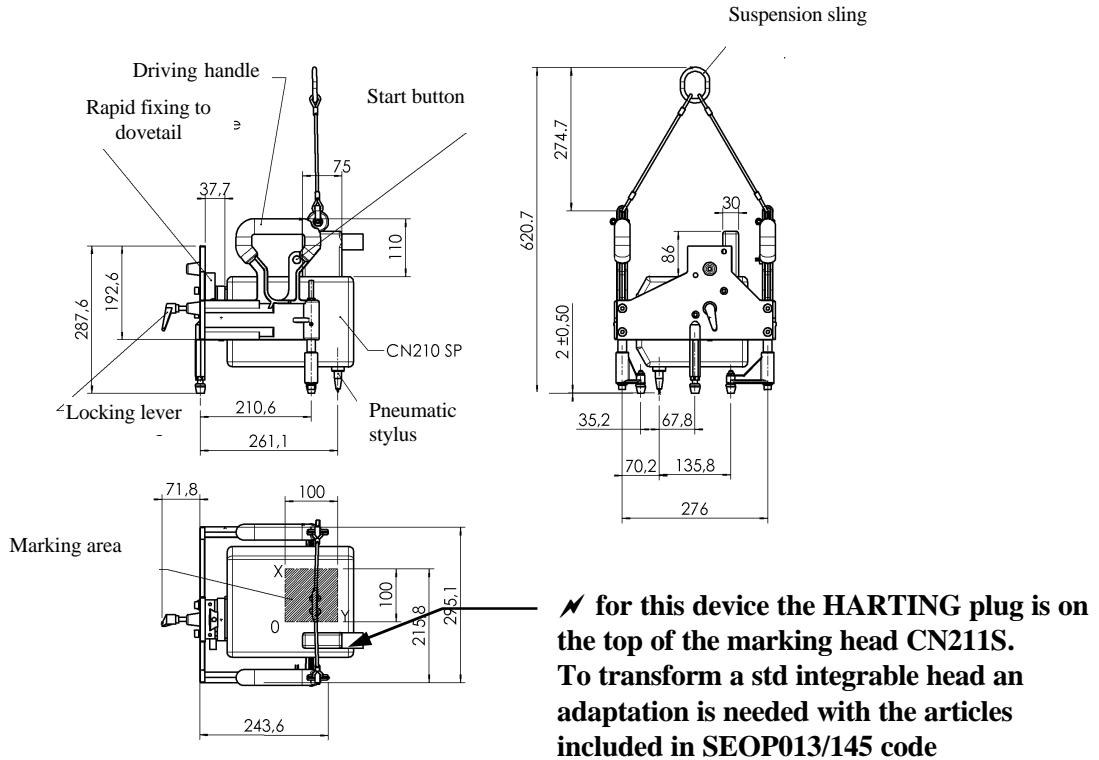

WEIGHT :

Head CN211Sp _____	8 kg
Hand-held unit and feet _____	6 kg
	14 kg

The unit is provided with a support ring for suspension.

SUPPLIED EQUIPMENT

Hand-held unit + feet without dove-tail for CN211Sp -----	SEOP009/11
Hand-held unit + feet without dove-tail for CN211Sm -----	SEOP009/12
Hand-held unit + feet with dove-tail for CN211Sp -----	SEOP009/9
Hand-held unit + feet with dove-tail for CN211Sm -----	SEOP009/13
Unit with 3 feet only -----	SEOP009/10
Marking head top casing -----	SEOP013/145

DIMENSIONAL PLAN

HEAD CN211 Sp + ves

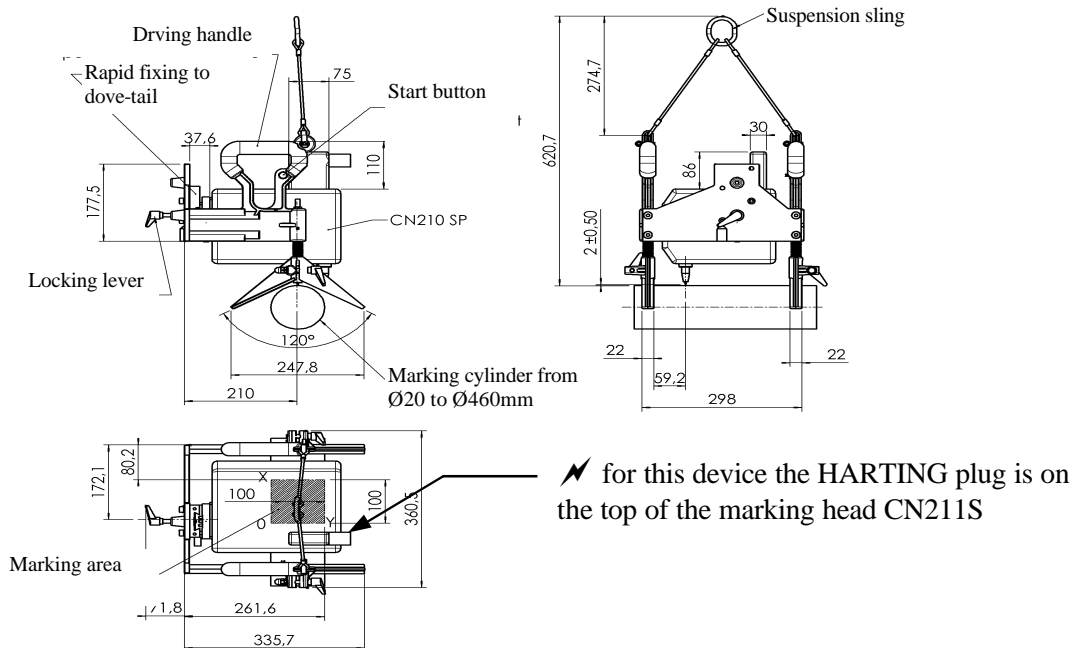

WEIGHT :

Head CN211Sp 8 kg
 Hand-held unit and ves 6 kg

The unit is provided with a support ring for suspension. 14 kg

SUPPLIED EQUIPMENT

Hand-held unit + ves without dove-tail for CN211Sp-----SEOP008/11
 Hand-held unit + ves without dove-tail for CN211Sm-----SEOP008/12
 Hand-held unit + ves with dove-tail for CN211Sp ----- SEOP008/9
 Hand-held unit + ves with dove-tail for CN211Sm-----SEOP008/13
 Unit with 2 ves only-----SEOP008/10
 Marking head top casing ----- SEOP013/145

FOR MORE INFORMATION PLEASE CONTACT US

TECHNIFOR France
 MIRIBEL
 Tél : (33) 04.78.55.85.85
 Fax : (33) 04.78.55.22.94

TECHNIFOR Europe
 MIRIBEL
 Tél : (33) 04.78.55.85.55
 Fax : (33) 04.78.55.85.54

TECHNIFOR Asie-Pacifique
 MIRIBEL
 Tél : (33) 04.78.55.85.58
 Fax : (33) 04.78.55.85.60