

ENFLEX

F 11

- toallitas
- tissues
- towelets
- tuchleinmaschine

# F11

- toallitas
- tissues
- towelets
- tuchleinmaschine



**Características**

El modelo F-11 toallitas de Enflex es una máquina envasadora automática horizontal para formar, llenar y soldar sobres.

Después de plegar en forma de "V" el film termosoldable, forma, llena y cierra los sobres.

El llenado con la toallita parte de una bobina de material y mediante un mecanismo pliega, corta e introduce la misma en el sobre conjuntamente con la dosificación del líquido, posteriormente cierra el sobre y lo corta unitariamente.

Posteriormente se pueden contar, agrupar y encartonar.

**Characteristics**

The F-11 model for towelettes from Enflex is an automatic horizontal packaging machine for shaping, filling, and sealing sachets.

After folding the thermosealable film in a "V" form, it shapes, fills and closes the sachets. The filling process begins with a reel of material and mechanically, folds, cuts and introduces the material into the sachet along with the liquide. Subsequently, closes and cuts the sachet.

**Caractéristiques**

Le modèle F-11 serviettes rafraichissantes Enflex est une machine automatique horizontale pour fabriquer, remplir et sceller les pochettes. Après le pliage en forme de "V" du film thermo-scellable, la machine forme, remplit et scelle les pochettes.

Le produit correspondant à la serviette est prélevé d'une bobine de matériel et, moyennant un mécanisme, la machine plie, coupe et introduit la serviette dans la pochette, incorporant le dosage du liquide utile.

Ensuite, la machine scelle les pochettes et les sépare par unité. Après, les pochettes seront comptées, regroupées et empaquetées.

**Eigenschaften**

Die Maschine arbeitet von der Rolle und faltet die Flachfolie zum Halbschlauch.

Nach Versiegeln der längsnaht wird das längs vorgefaltete Vlies mit einem Faltschwert in den Beutel eingeschoben. Gleichzeitig wird die Flüssigkeit in gewünschter Menge zudosiert.

Auf den folgenden Stationen wird der Beutel oben verschlossen, und anschließend vorn Strang getrennt.

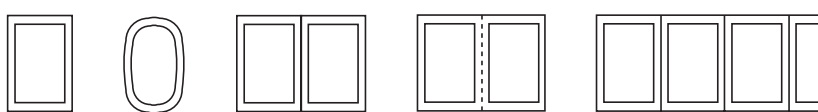
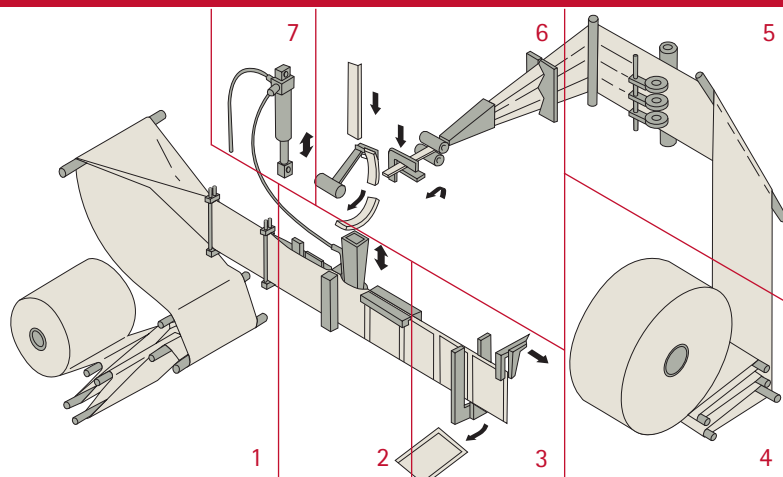

- |                            |   |
|----------------------------|---|
| 1 ● Formado de sobres      | 5 ● Marcado toallitas                   |
| ● Formation des sachets    | ● Marquage des serviettes               |
| ● Sachets forming          | ● Towelettes marking                    |
| ● Vorformung               | ● Tuchmarkierung                        |
| 2 ● Llenado y sellado      | 6 ● Plegado e introducción de toallitas |
| ● Dosage et scellage       | ● Pliage et introduction des serviettes |
| ● Filling and sealing      | ● Falten und einführen des tüchleins    |
| ● Füllung und Versiegelung | 7 ● Dosificación líquido                |
| 3 ● Corte                  | ● Dosage du liquide                     |
| ● Découpe                  | ● Liquid dosing                         |
| ● Cutting                  | ● Flüssigkeitsdosierung                 |
| ● Schnitt                  |   |
| 4 ● Desbobinador           |   |
| ● Débobinage               |   |
| ● Unwinder                 |   |
| ● Abrollhaspel             |   |

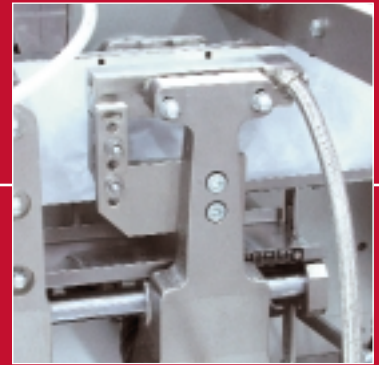
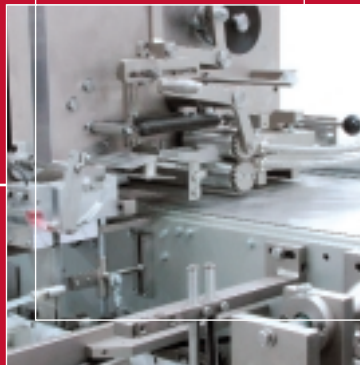
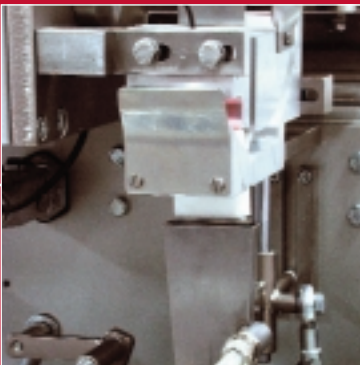

# F11

- toallitas
- tissues
- towelets
- tuchleinmaschine



<ul style="list-style-type: none"> <li>○ Datos técnicos</li> <li>● Technical data</li> <li>● Données techniques</li> <li>○ Technische daten</li> </ul>		<b>F-11</b> toallitas tissues towelets tüchleinmaschine		
<ul style="list-style-type: none"> <li>● Dimensiones sobre (mm)</li> <li>● Sachet dimensions (mm)</li> <li>● Mesures sachet (mm)</li> <li>● Beutemaß in mm. (mm)</li> </ul>	<ul style="list-style-type: none"> <li>● Mínimo / Máximo</li> <li>● Minimum / Maximum</li> <li>● Minimal / Maximal</li> </ul>	<b>45 x 70 / 110 x 130</b>		
<ul style="list-style-type: none"> <li>● Dimensiones toallita (mm)</li> <li>● Towel dimensions (mm)</li> <li>● Mesures serviettes (mm)</li> <li>● Enfrischungstücher Ausmasse (mm)</li> </ul>	<ul style="list-style-type: none"> <li>● Mínimo / Máximo</li> <li>● Minimum / Maximum</li> <li>● Minimal / Maximal</li> </ul>	<b>60 x 102 / 300 x 240</b>		
<ul style="list-style-type: none"> <li>● Tipo de doblado</li> <li>● Fold type</li> <li>● Type de pliage</li> <li>● Art der Faltung</li> </ul>	<ul style="list-style-type: none"> <li>● Doble</li> <li>● Double</li> <li>● Double</li> <li>● Doppelt</li> </ul>		<ul style="list-style-type: none"> <li>● Triple</li> <li>● Triplex</li> <li>● Triple</li> <li>● Dreifache</li> </ul>	
<ul style="list-style-type: none"> <li>● Ancho de toallita plegada (a)</li> <li>● Width of folded towel (a)</li> <li>● Largeur de serviette pliè (a)</li> <li>● Länge des gefalteten tuches (a)</li> </ul>	<ul style="list-style-type: none"> <li>● Mínimo / Máximo</li> <li>● Minimum / Maximum</li> <li>● Minimal / Maximal</li> </ul>	<b>17 / 70</b>		
<ul style="list-style-type: none"> <li>● Volumen c.c.</li> <li>● Volume in c.c.</li> <li>● Volume en c.c.</li> <li>● Füllmenge in ccm.</li> </ul>	<ul style="list-style-type: none"> <li>● Máximo</li> <li>● Maximum</li> <li>● Maximal</li> </ul>	<b>8</b>		
<ul style="list-style-type: none"> <li>● Producción mecánica hasta ... sobres/minuto</li> <li>● Mechanical output ... sachets/minute</li> <li>● Production machanique ... sachets/minute</li> <li>● Produktion ... beutel/minute</li> </ul>			<b>100</b>	
<ul style="list-style-type: none"> <li>● Consumo en kW.</li> <li>● Consumption in kW.</li> <li>● Consommation en kW.</li> <li>● Verbrauch in kW</li> </ul>			<b>3,4</b>	
<ul style="list-style-type: none"> <li>● Datos eléctricos</li> <li>● Electrical data</li> <li>● Données életriques</li> <li>● Elektrische daten</li> </ul>			<b>380 volt./3 fases/50Hz + Neutro + Tierra (otros S/pedido)</b> <b>380 volt./3 phases/50Hz + Neutral + Ground (other available by special order)</b> <b>380 volt./3 phases/50Hz + Neutre + Terre (autres sur commande)</b> <b>380 volt./3 phasen/50Hz + Neutral + Erddung (andere nach Bestellung)</b>	
<ul style="list-style-type: none"> <li>● Dimensiones bobina</li> <li>● Reel dimensions</li> <li>● Dimensiones bobine</li> <li>● Folienrollen-abmessung</li> </ul>	<ul style="list-style-type: none"> <li>● Diámetro máximo mm.</li> <li>● Max. diameter mm.</li> <li>● Diamètre max. mm.</li> <li>● Höchstdurchmesser in mm.</li> </ul>	<b>450</b>		
	<ul style="list-style-type: none"> <li>● Ancho máximo mm.</li> <li>● Max. width mm.</li> <li>● Largeur max. mm.</li> <li>● Hochsbreite in mm.</li> </ul>	<b>260</b>		
	<ul style="list-style-type: none"> <li>● Diámetro núcleo mm.</li> <li>● Core diameter mm.</li> <li>● Diamètre noyau mm.</li> <li>● Kerndurchmesser in mm.</li> </ul>	<b>70 / 75</b>		
<ul style="list-style-type: none"> <li>● Peso neto en kg</li> <li>● Net weight in kg</li> <li>● Poids net en kg</li> <li>● Netto gewicht in kg</li> </ul>			<b>770</b>	
<ul style="list-style-type: none"> <li>● Dimensiones máquina (largo x ancho x alto) en m.</li> <li>● Machine dimensions (lenght x width x heigth) in metres.</li> <li>● Dimensiones machine (longeur x largeur x hauteur) en mètres.</li> <li>● Ausmasse (länge x breite x höhe) in m.</li> </ul>			<b>1,86 x 2,20 x 1,8</b>	