

1305H "C"			1000 Kg		
ACCIONES SOBRE EL HUECO			13 P.		
R1	CARGA BAJO PISTON	65500 N	0.5 m/s		
R2	CARGA BAJO AMORTIGUADOR DE CABINA	74600 N	FOSO	HUIDA	
R3	CARGA BAJO GUIAS DE CABINA	22500 N	1400	3600	18,4 Kw
	REACCION DE GUIAS EN DIRECCION X	6600 N			
	REACCION DE GUIAS EN DIRECCION Y	1900 N			

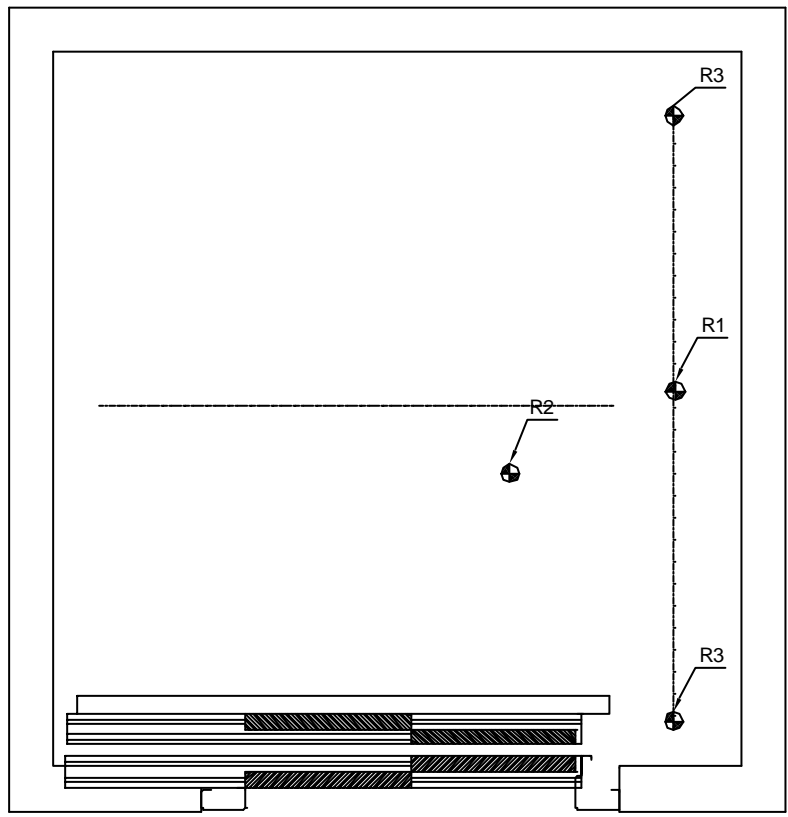

1305H "C"			1000 Kg		
ACCIONES SOBRE EL HUECO			13 P.		
R1	CARGA BAJO PISTON	65500 N	0.5 m/s		
R2	CARGA BAJO AMORTIGUADOR DE CABINA	74600 N	FOSO	HUIDA	
R3	CARGA BAJO GUIAS DE CABINA	22500 N	1400	3600	18,4 Kw
	REACCION DE GUIAS EN DIRECCION X	6600 N			
	REACCION DE GUIAS EN DIRECCION Y	1900 N			

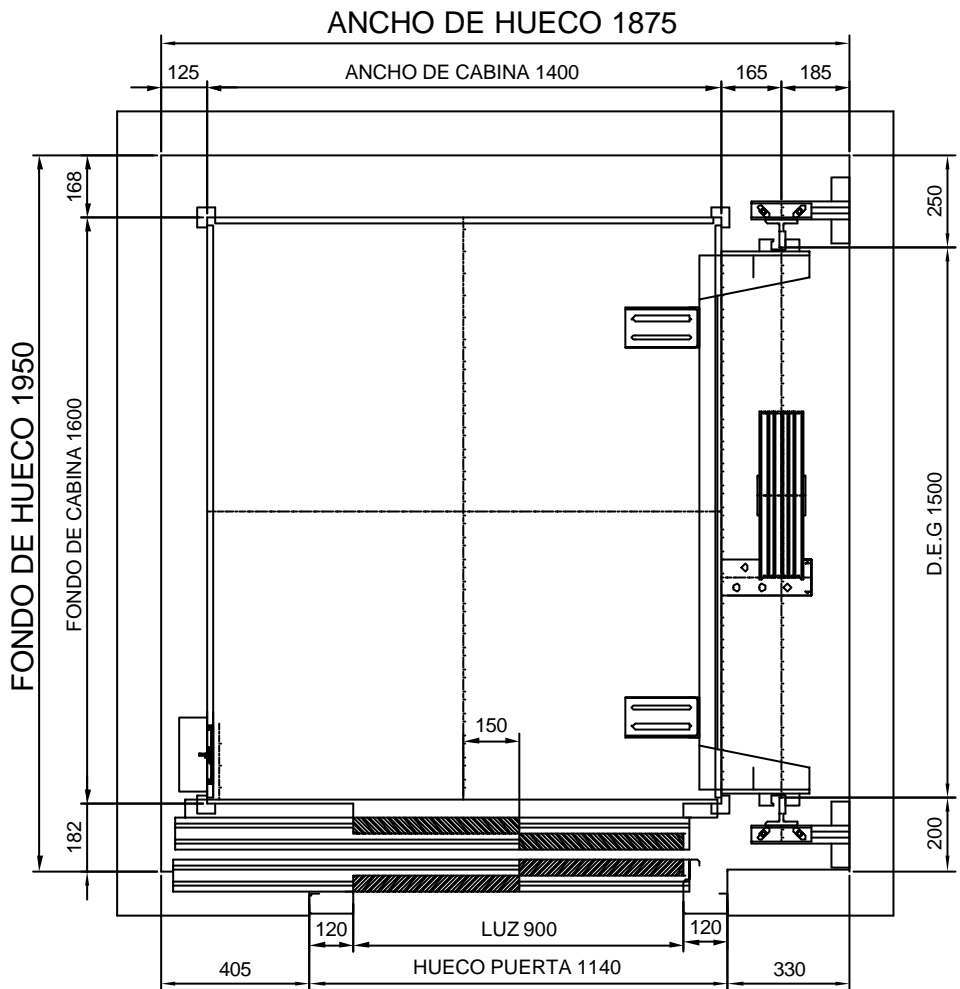