

EXTRACTORES CENTRÍFUGOS DE SIMPLE ASPIRACIÓN

PARA 400°C/2h INMERSOS

Serie CHMT

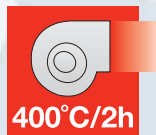

Homologados según norma EN12101-3
Certificación nº 0370-CPD-0346

Ventiladores centrífugos de simple aspiración, para trabajar inmersos en ambientes 400°C/2h, carcasa protegida con pintura poliéster anticorrosiva, rodete de acero galvanizado de álabes hacia adelante **equilibrado dinámicamente**, motor trifásico, IP55, Clase H, para usos en **funcionamiento continuo (S1) o para casos de emergencia (S2)**.

Motores

De 4 ó 6 polos, según versiones.

Modelos de 2 velocidades, bajo demanda.

Tensión de alimentación

Trifásicos 230/400V-50Hz, hasta 3 kW

400V-50Hz, para potencias superiores

(Ver cuadro de características).

Otros datos

Los motores pueden situarse a derecha o izquierda. **Voluta orientable**, en ambos casos, para ofrecer **16 combinaciones distintas**.

Orientación estándar: LG 270.



Motor 400°C/2h homologado S1 y S2

Rodete equilibrado dinámicamente



Motor 400°C/2h, homologado para funcionar en uso continuo (S1), y en caso de emergencia (S2)

Rodete de álabes hacia adelante, **equilibrado dinámicamente** según norma ISO 1940, para **reducir el ruido** y evitar vibraciones

APLICACIONES



Parkings



Cocinas

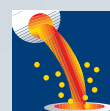

Siderurgia Fundición



O R I E N T A C I O N E S

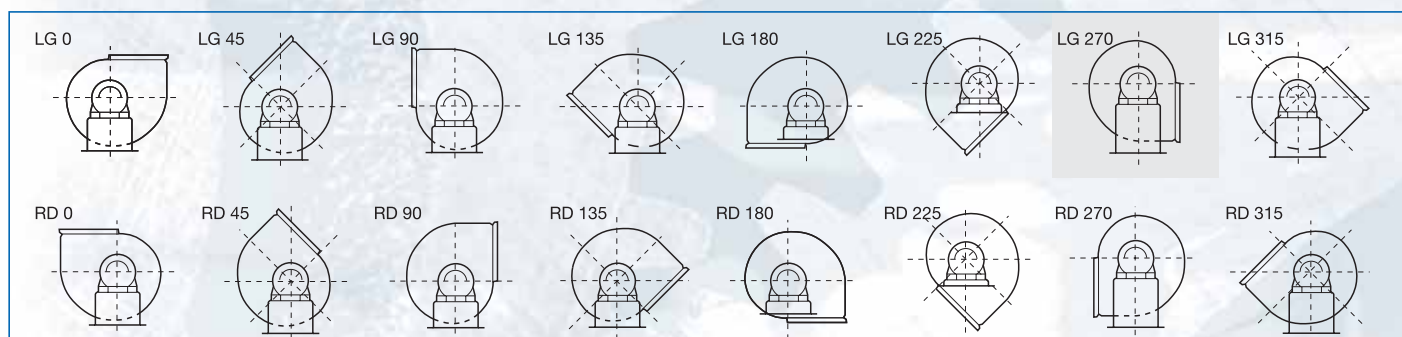

Orientación estándar: LG 270. El resto de las orientaciones se fabrican bajo demanda.

■ Características técnicas

Es imprescindible comprobar que las características eléctricas (voltaje, intensidad, frecuencia, etc.) del motor que aparecen en la placa del mismo son compatibles con las de la instalación.

Modelo	Velocidad (r.p.m.)	Potencia útil (kW)	Intensidad máxima absorbida (A)		Caudal máximo (m³/h)	Nivel de presión sonora (dB(A))	Peso (kg)
			230 V	400 V			
4 POLOS TRIFASICOS							
CHMT/4-225/90-0,75	1415	0,75	2,6	1,5	2600	71	34
CHMT/4-250/100-1,1	1390	1,1	4,7	2,7	3600	72	39,2
CHMT/4-250/100-1,5	1400	1,5	6,6	3,8	3900	73	41,5
CHMT/4-280/115-2,2	1400	2,2	9,5	5,5	5050	75	64
CHMT/4-315/130-2,2	1400	2,2	9,5	5,5	5450	72	70
CHMT/4-315/130-3	1400	3	13	7,5	6400	75	75
CHMT/4-315/130-4	1420	4	-	9,5	7100	78	80
CHMT/4-355/145-3	1400	3	13	7,5	6200	75	77
CHMT/4-355/145-4	1420	4	-	9,5	7700	78	82
CHMT/4-355/145-5,5	1440	5,5	-	12,5	9300	81	105
CHMT/4-355/145-7,5	1445	7,5	-	16	10700	83	113
CHMT/4-400/165-4	1420	4	-	9,5	7200	77	97
CHMT/4-400/165-5,5	1440	5,5	-	12,5	8300	80	120
CHMT/4-400/165-7,5	1445	7,5	-	16	10460	83	128
CHMT/4-450/185-5,5	1470	5,5	-	12,9	7560	83	130
CHMT/4-450/185-7,5	1470	7,5	-	16	9900	86	138
CHMT/4-500/205-11	1467	11	-	23	11250	87	163
CHMT/4-500/205-15	1470	15	-	31	15930	89	180
6 POLOS TRIFASICOS							
CHMT/6-315/130-1,1	965	1,1	3,3	5,7	5400	69	70
CHMT/6-355/145-1,1	965	1,1	3,3	5,7	6700	74	72
CHMT/6-400/165-2,2	975	2,2	3,7	6,3	7590	73	97
CHMT/6-450/185-2,2	975	2,2	3,7	6,3	7110	75	107

ATENCIÓN: Los valores de los niveles sonoros son presiones sonoras en dB(A) calculadas a 1,5 m a la descarga de los extractores, con el caudal máximo (Q máx).



■ Características acústicas

Espectros de potencias sonoras en dB(A) por banda de frecuencia en (Hz).

ESPECTRO DE POTENCIAS								
Descripción	63 Hz	125 Hz	250 Hz	500 Hz	1000 Hz	2000 Hz	4000 Hz	8000 Hz
4 POLOS								
CHMT/4-225/90 - 0,75	55	67	74	75	80	81	77	73
CHMT/4-250/100 - 1,1	56	69	75	76	81	82	78	75
CHMT/4-250/100 - 1,5	56	69	75	76	81	82	78	75
CHMT/4-280/115 - 2,2	59	72	78	79	84	85	81	78
CHMT/4-315/130 - 2,2	56	69	75	76	81	82	78	75
CHMT/4-315/130 - 3	59	72	78	79	84	85	81	78
CHMT/4-315/130 - 4	62	75	81	82	87	88	84	81
CHMT/4-355/145 - 3	59	72	78	79	84	85	81	78
CHMT/4-355/145 - 4	62	75	81	82	87	88	84	81
CHMT/4-355/145 - 5,5	65	78	84	85	90	91	87	84
CHMT/4-355/145 - 7,5	66	79	85	86	91	92	88	85
CHMT/4-400/165 - 4	61	74	80	81	86	87	83	80
CHMT/4-400/165 - 5,5	64	77	83	84	89	90	86	83
CHMT/4-400/165 - 7,5	67	80	86	87	92	93	89	86
CHMT/4-450/185 - 5,5	67	80	86	87	92	93	89	86
CHMT/4-450/185 - 7,5	70	83	89	90	95	96	92	89
CHMT/4-500/205 - 11	71	84	90	91	96	97	93	90
CHMT/4-500/205 - 15	73	86	92	93	98	99	95	92
6 POLOS								
CHMT/6-315/165 - 1,1	54	67	70	78	78	79	74	70
CHMT/6-355/145 - 1,1	56	69	72	80	80	81	76	72
CHMT/6-400/165 - 2,2	58	70	73	81	81	82	78	74
CHMT/6-450/185 - 2,2	60	73	76	84	84	85	80	76

TOTAL	
Potencia	Presión
4 POLOS	
85	71
87	72
87	72
90	75
87	72
90	75
93	78
90	75
93	78
96	81
97	82
92	77
95	80
98	83
98	83
101	86
102	87
104	89
6 POLOS	
84	70
86	72
87	73
90	76

■ Dimensiones (mm)

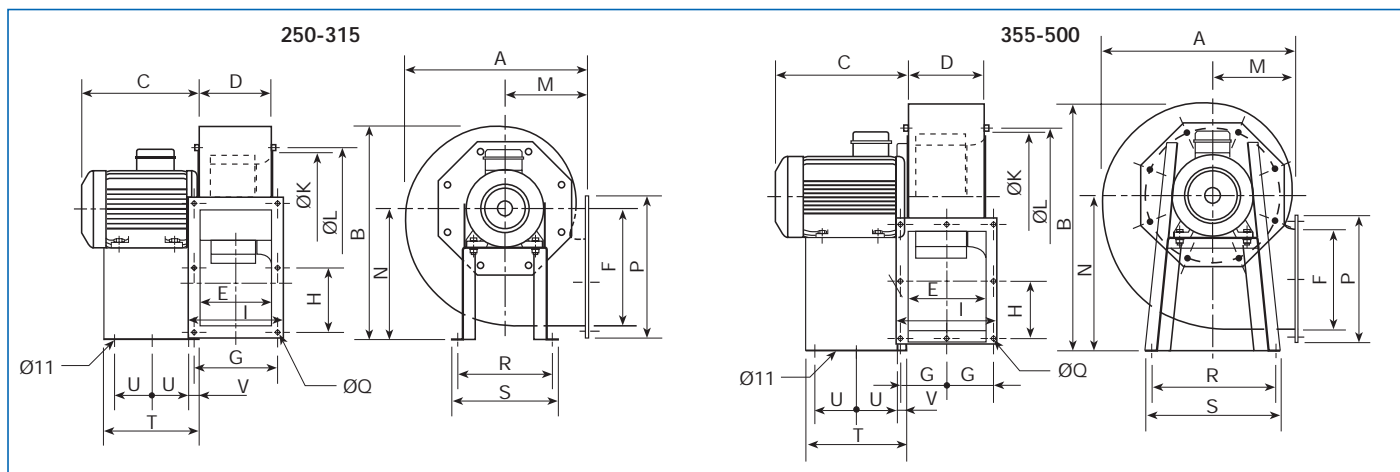

Modelo CHMT	A	B	C máx	D	E	F	G	H	I	K	L	M	N	P	Q	R	S	T	U	V
225/90	386	452	180	144	140	216	180	128	203	234	256	181	280	279	10	220	250	200	50	27
250/100	427	503	290	168	165	250	205	145	228	252	282	197	310	313	10,5	228	260	225	74	27
280/115	467	547	320	183	180	300	220	170	243	292	320	215	340	363	10,5	245	275	240	95	27
315/130	525	630	340	203	200	320	240	180	263	325	354	238	390	383	11	322	352	230	140	20
355/145	566	707	435	231	227	280	133	159	291	365	394	250	445	343	11	420	450	333	136,5	30
400/165	628	792	435	254	249	320	150	185	334	410	438	270	495	404	11	402	438	327	133,5	30
450/185	709	898	391	288	284	360	164	202	368	463	485	302	560	444	11	502	538	340	140	30
500/205	795	984	526	319	315	450	182,5	250	409	513	535	345	610	544	11	613	653	435	187,5	30

■ Curvas características

- Q = Caudal en m³/h y m³/s.
- Pe = Presión estática en mm.c.d.a y Pa.
- Aire seco normal a 20 °C y 760 mm c.d. Hg.
- Ensayos realizados de acuerdo a Normas UNE 100-212-89 BS 848, Part 1; AMCA 210-85 y ASHRAE 51-1985.

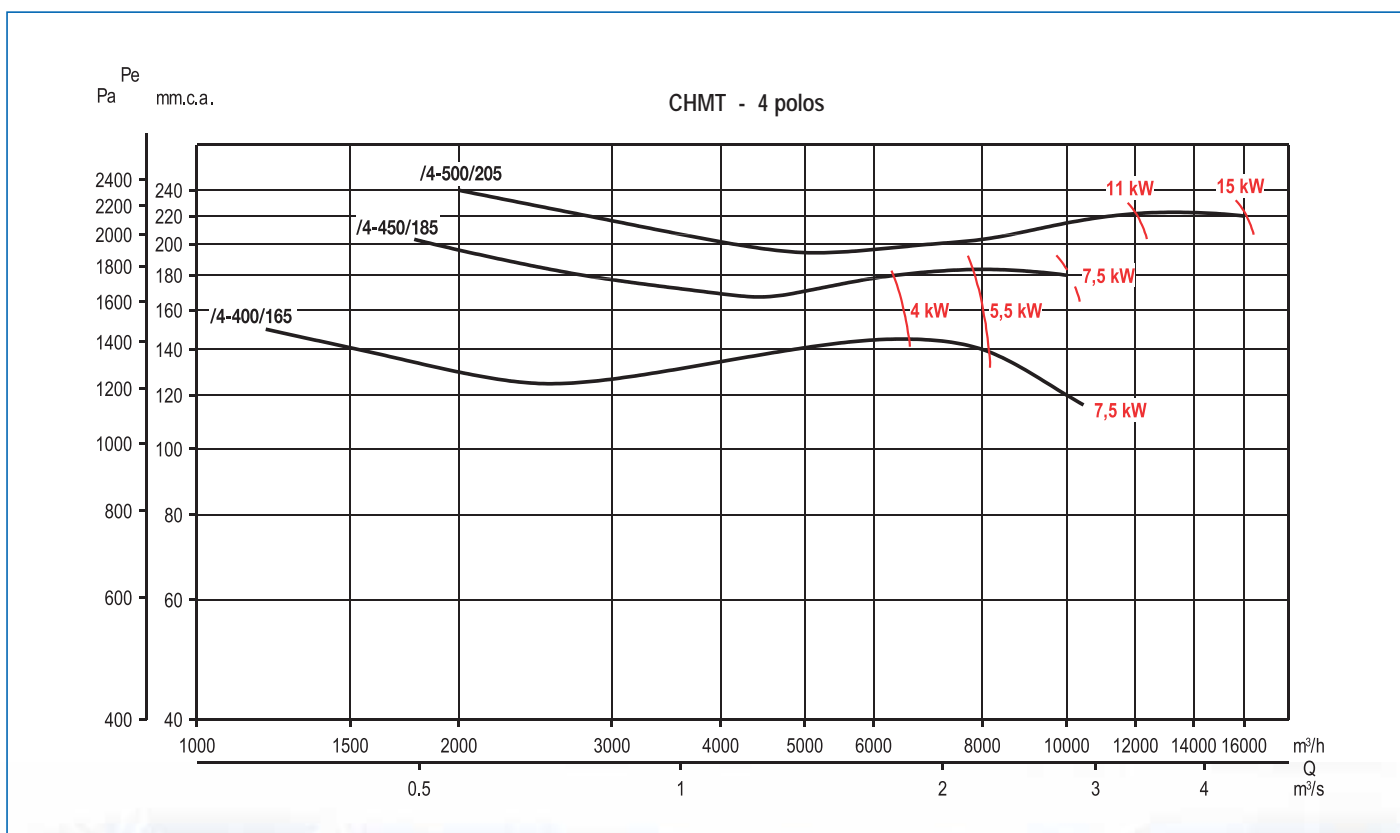
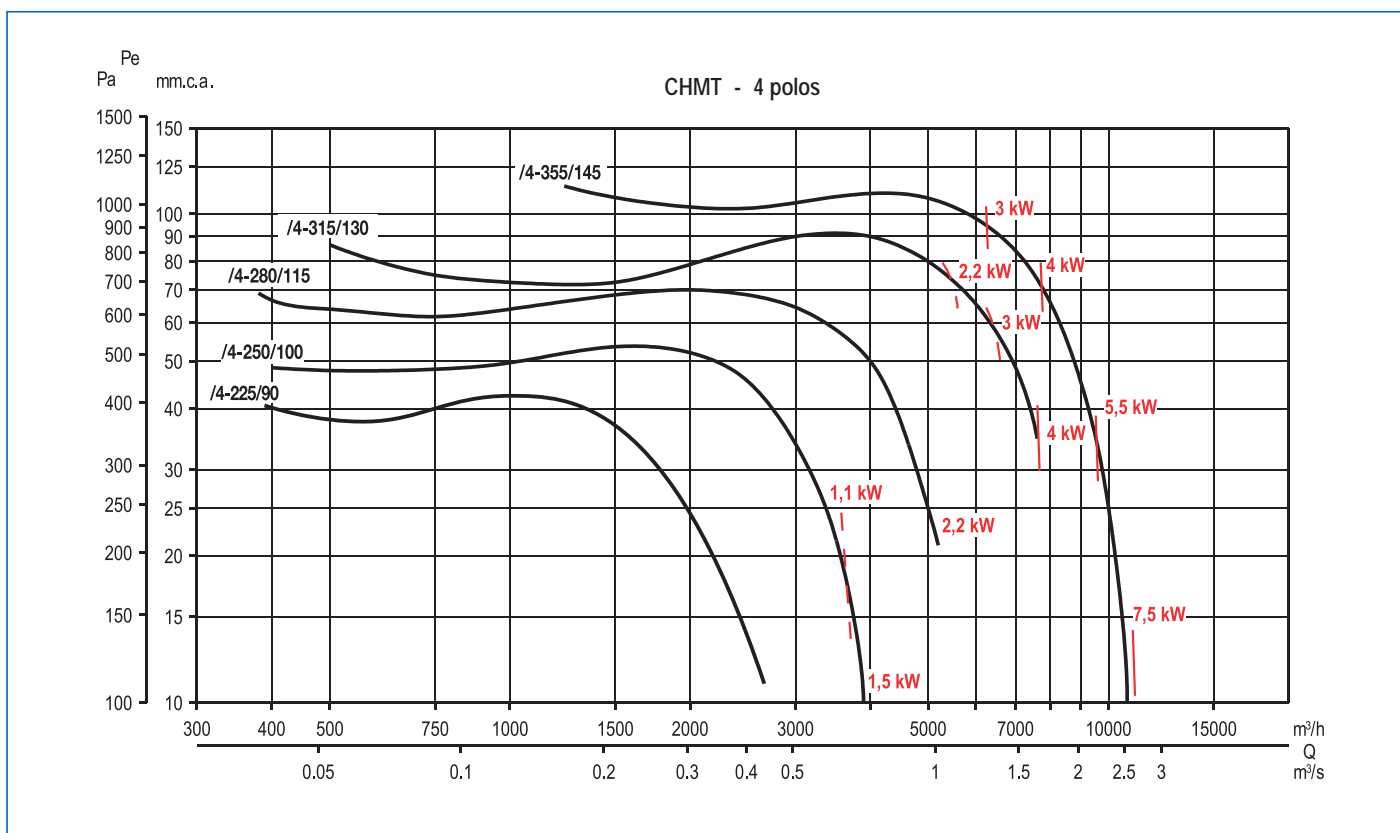

■ Curvas características

- Q = Caudal en m³/h y m³/s.
- Pe = Presión estática en mm.c.d.a y Pa.
- Aire seco normal a 20 °C y 760 mm c.d. Hg.
- Ensayos realizados de acuerdo a Normas UNE 100-212-89 BS 848, Part 1; AMCA 210-85 y ASHRAE 51-1985.

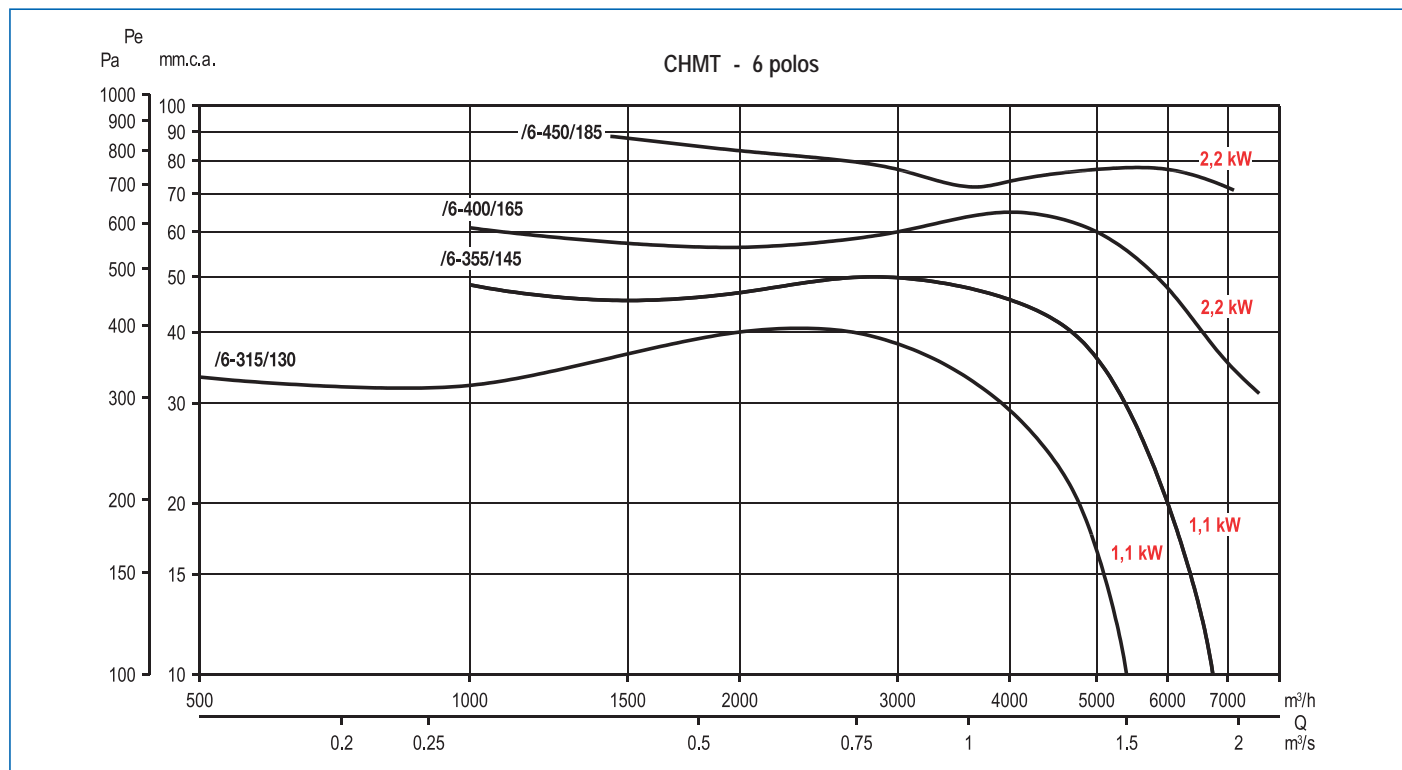

■ Accesorios de montaje

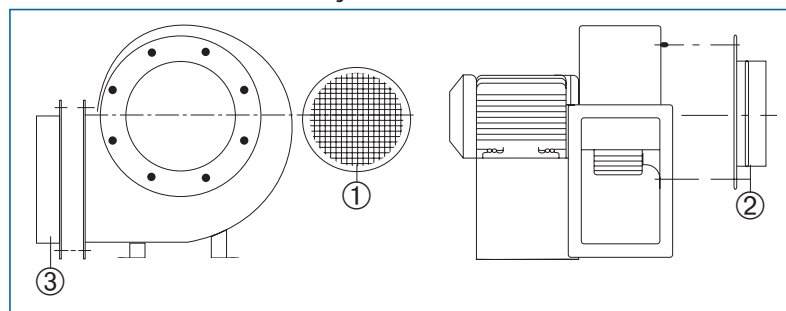

Modelo CHMT	① Rejilla	② Brida de aspiración	③ Brida de descarga
225/90	KRJ-225	KBA-225	KBD-225
250/100	KRJ-250	KBA-250	KBD-250
280/115	KRJ-280	KBA-280	KBD-280
315/130	KRJ-315	KBA-315	KBD-315
355/145	KRJ-355	KBA-355	KBD-355
400/165	KRJ-400	KBA-400	KBD-400
450/185	KRJ-450	KBA-450	KBD-450
500/205	KRJ-500	KBA-500	KBD-500

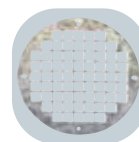
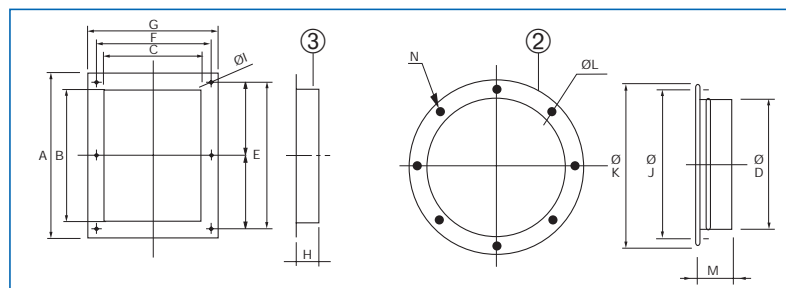

KRJ
Rejilla Defensa de Aspiración



KBA
Brida Circular Aspiración

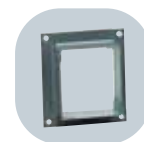

KBD
Brida Rectangular Descarga

Modelo de accesorio	A	B	C	ØD	E	F	G	H	Ø I	Ø J	Ø K	Ø L	M	N
225/90	279	219	143	224	256	180	203	45	10	256	280	9	65	8
250/100	313	253	168	250	290	205	228	45	10	282	306	9	65	8
280/115	363	303	183	280	340	220	243	50	10	320	348	9	65	8
315/130	383	323	203	315	360	240	263	50	11	354	382	9	65	8
355/145	343	283	231	355	318	266	291	50	11	394	422	9	65	8
400/165	404	324	254	400	370	300	334	55	11	438	464	9	65	8
450/185	444	364	288	450	404	328	368	55	11	485	515	9	65	8
500/205	544	454	319	500	500	365	409	60	11	535	565	9	65	8