

Cierres magnéticos

CIERRES MAGNÉTICOS. FABRICADOS EN MATERIAL PLÁSTICO, UN IMÁN PERMANENTE Y SUS CHAPAS DE HIERRO DULCE ZINCADO

	<i>págs.</i>
1 CIERRES MAGNÉTICOS	26
■ TOPES CON TIRAFONDOS	26
■ TIRAFONDO	26
■ PARA ATORNILLAR Y TOPE MÓVIL	27



1 CIERRES MAGNÉTICOS

CIERRES MAGNÉTICOS. FABRICADOS EN MATERIAL PLÁSTICO, UN IMÁN PERMANENTE Y SUS CHAPAS DE HIERRO DULCE ZINCADO.

CIERRE MAGNÉTICO.

			
BLANCO	281.004.006		
4 KGS. MARRÓN	281.004.010	100 ó 500	
NEGRO	281.004.021		

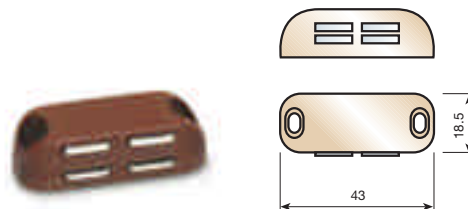

CIERRE MAGNÉTICO.

			
BLANCO	281.104.003		
4 KGS. MARRÓN	281.104.014	100 ó 500	
NEGRO	281.104.025		

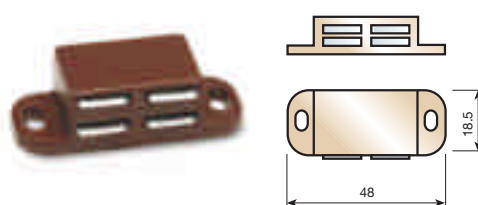

TOPES CON TIRAFONDOS

TOPE DE CIERRE CON UN TIRAFONDO.

			
ZINCADO	282.100.033	100 ó 2.000	

SE SUMINISTRA CON UN TIRAFONDO Ø2,70 x 13.

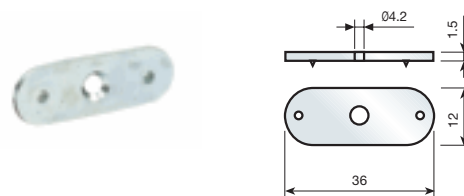

TOPE DE CIERRE CON DOS TIRAFONDOS.

			
ZINCADO	282.200.030	1.000 ó 5.000	

SE SUMINISTRA CON DOS TIRAFONDOS Ø2,70 x 13.

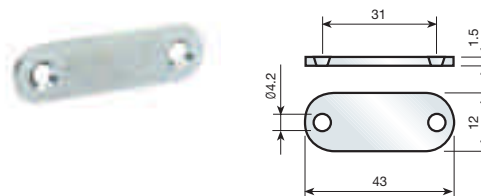

TIRAFONDO

TIRAFONDO SUJECIÓN CUERPO.

			
Ø 3 x 15	986.915.031	1.000 ó 5.000	



PARA ATORNILLAR Y TOPE MÓVIL

CIERRE MAGNÉTICO PARA ATORNILLAR Y TOPE MÓVIL Ø14 MM.

			
BLANCO	281.404.001		
4 KGS. MARRÓN	281.404.012	50 ó 500	
NEGRO	281.404.023		

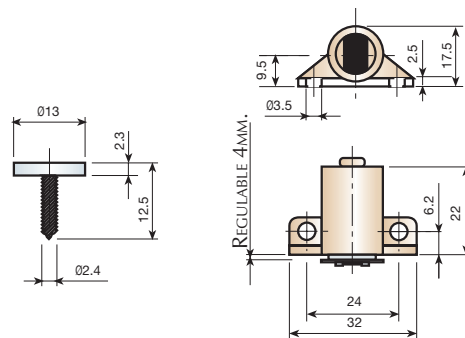

CIERRE MAGNÉTICO CON CHAPA PARA ATORNILLAR Y TOPE MÓVIL Ø14 MM.

			
BLANCO	281.504.005		
4 KGS. MARRÓN	281.504.016	50 ó 500	
NEGRO	281.504.020		

