

Herrajes para puertas ligeras

HERRAJES PARA PUERTAS CORREDERAS APOYADAS:
PUERTAS LIGERAS EN MADERA O ALUMINIO. PUERTAS HASTA 50Kp.
PUERTAS DE ARMARIO SIN MECANIZACIÓN. PUERTA JAPONESA SIN MECANIZACIÓN.

	<i>págs.</i>
1 "JUNIOR-0"	576
<hr/>	
2 "JUNIOR-1"	577
<hr/>	
3 "MINI"	578
<hr/>	
4 "TALL"	579
<hr/>	
5 "UPPER"	580
<hr/>	
6 "DÚO"	582

1 "JUNIOR-0"

PERFIL SUPERIOR PARA PUERTA INTERIOR

	CORTADO A MEDIDA	BARRA DE 6M.	
NATURAL	706.000.503	706.060.504	10

EN BARRAS DE 6M.



PERFIL INFERIOR PARA PUERTA INTERIOR

	CORTADO A MEDIDA	BARRA DE 6M.	
NATURAL	706.100.500	706.160.501	10

EN BARRAS DE 6M.



CONJUNTO DE HERRAJES PARA PUERTA INTERIOR

		
PUERTA	705.500.106	10

EMPAQUETADO EN UNA CAJA DE 10 BOLSAS CONTENIENDO LOS CARROS INFERIORES Y PATINES SUPERIORES NECESARIOS PARA UNA PUERTA CADA UNA.

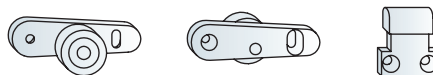

PERFIL INFERIOR/SUPERIOR PARA PUERTA EXTERIOR

	CORTADO A MEDIDA	BARRA DE 6M.	
NATURAL	706.200.504	706.260.505	10

EN BARRAS DE 6M.



CONJUNTO DE HERRAJES PARA PUERTA EXTERIOR

		
PUERTA	705.600.103	10

EMPAQUETADO EN UNA CAJA DE 10 BOLSAS CONTENIENDO LOS CARROS SUPERIORES, INFERIORES Y TOPES NECESARIOS PARA UNA PUERTA CADA UNA.

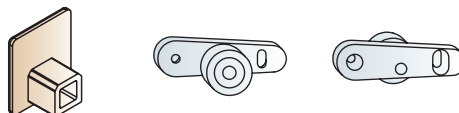

Ejemplo puerta interior de madera

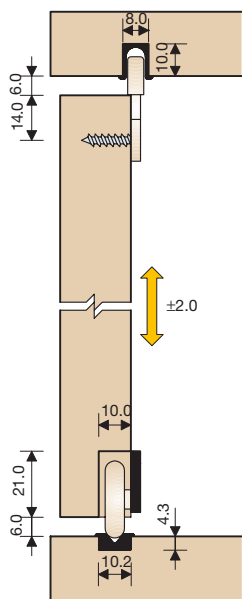

Ejemplo puerta exterior de aluminio

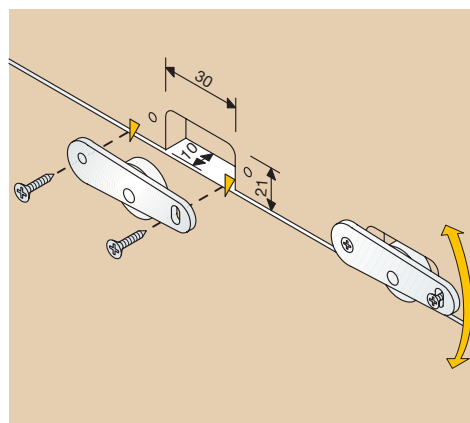
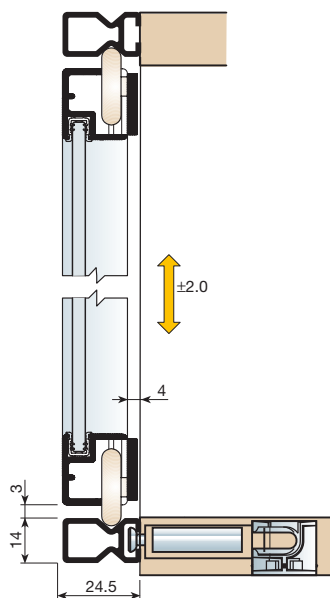

2 "JUNIOR-1"

PERFIL GUÍA SUPERIOR/INFERIOR

				
BLANCO	RAL 9003	721.006.005		25
MARRÓN	RAL 8016	721.006.016		
NEGRA	RAL 9005	721.006.020		
ROBLE	RAL 1002	721.006.193		

EN TIRAS DE 2M.

CUERPO SUPERIOR

				
MARRÓN	RAL 8016	721.707.011	200	

CUERPO INFERIOR

				
MARRÓN	RAL 8016	721.807.015	200	

TOPE REMATE DEL PERFIL

				
BLANCO	RAL 9003	741.606.003		200
MARRÓN	RAL 8016	741.606.014		
NEGRA	RAL 9005	741.606.025		
ROBLE	RAL 1002	741.606.191		

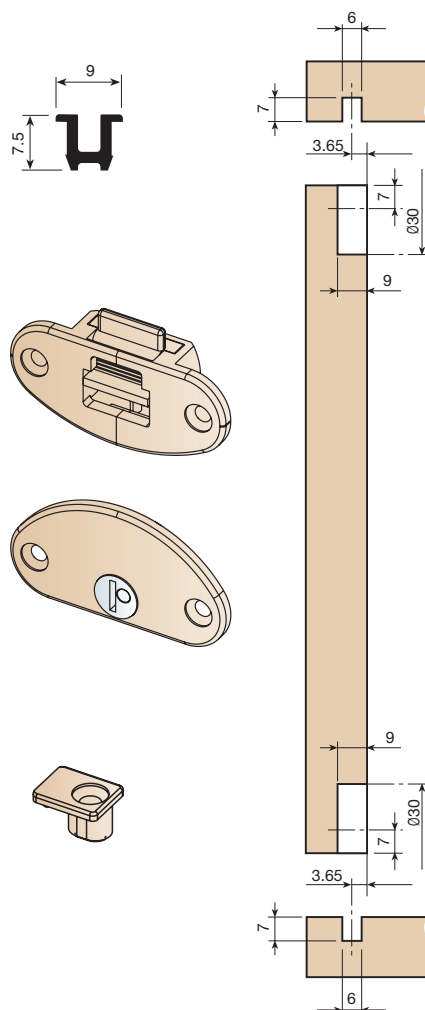

DATOS TÉCNICOS

ESTA CORREDERA ES DE GRAN LIGEREZA Y FÁCIL COLOCACIÓN. LA PARTE INFERIOR DISPONE DE UN SISTEMA QUE PERMITE REGULAR LA PUERTA 2 MM. ESTÁ PREVISTA HASTA PUERTAS DE 12 KGS. DE PESO.

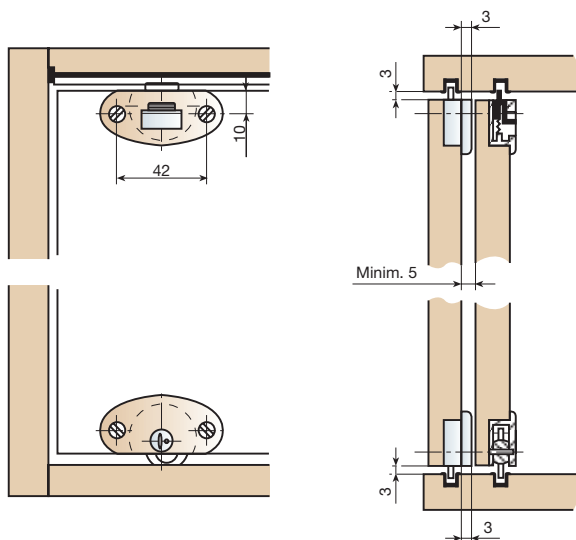

3 "MINI"

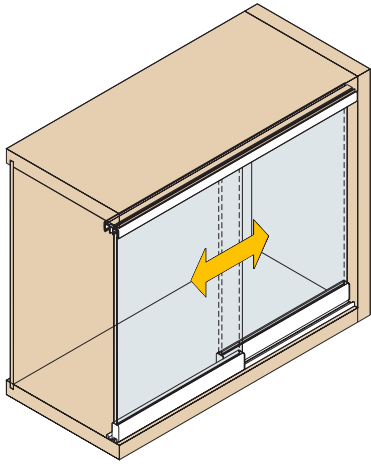

CONJUNTO DE PERFILES

PLATA MATE	709.900.516	1
------------	-------------	---

CADA REF. SE COMPONE DE 1 PERFIL SUPERIOR CON JUNQUILLO Y 1 PERFIL INFERIOR.



CONJUNTO DE HERRAJES PARA PUERTA

PLATA MATE	709.700.515	1
------------	-------------	---

CADA REF. SE COMPONE DE 1 PERFIL Y 2 CARROS.

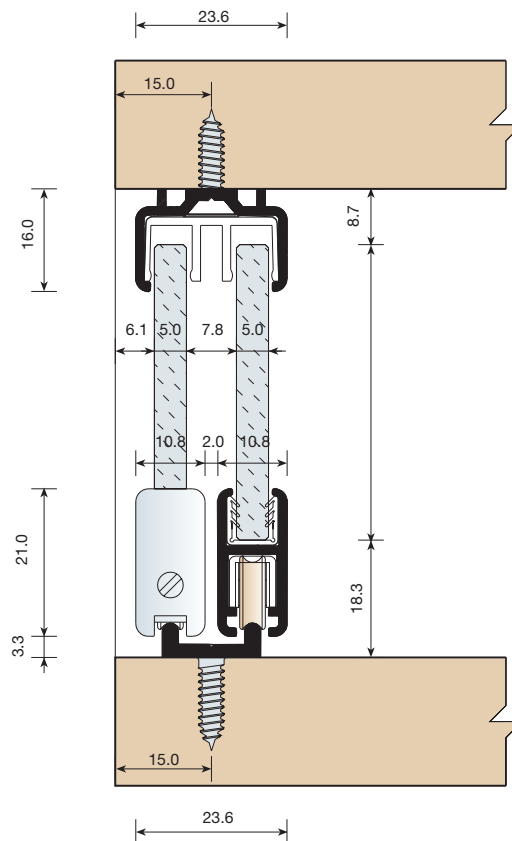
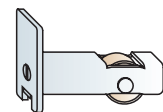

4 "TALL"

BOLSA DE COMPONENTES

ANODIZADO PLATA MATE	709.400.510 1

CADA BOLSA CONTIENE:

	UNIDADES
PERFIL VITRINA A	4
PERFIL GUÍA B	2
PERFIL DESLIZAMIENTO C	2
ESCUADRA DE UNIÓN D	4

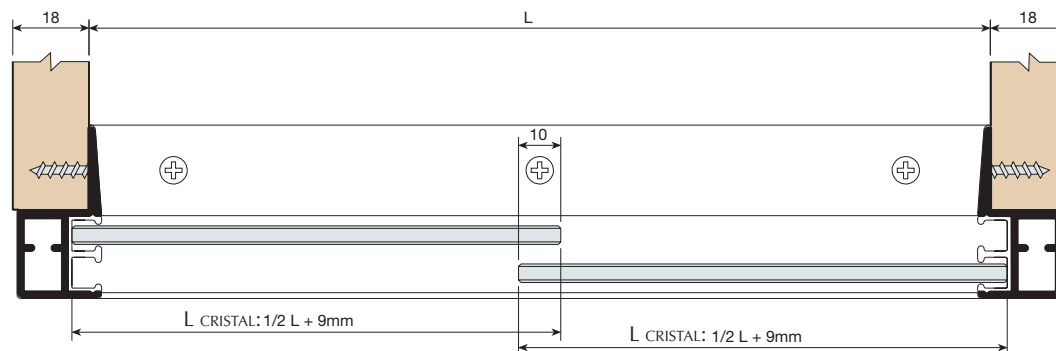
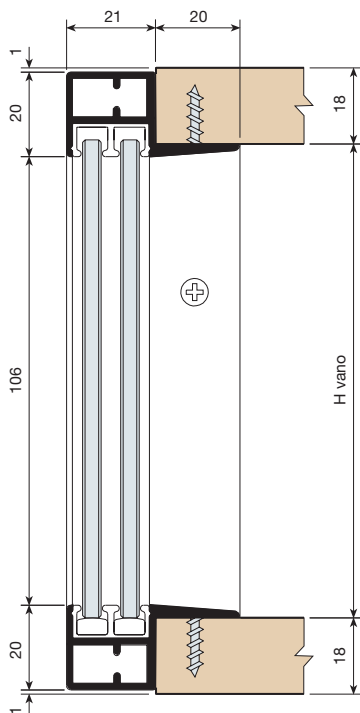
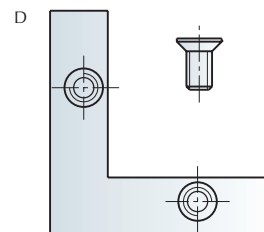
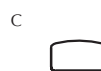

5 "UPPER"

PERFIL SUPERIOR

	CORTADO A MEDIDA	BARRA DE 3M.	
PLATA MATE	709.500.514	709.530.511	10



CONJUNTO DE HERRAJES

1 PUERTA	709.600.102	10
----------	-------------	----

CADA REF. SE COMPONE DE 2 CARROS SUPERIORES, 2 FRENOS, 1 PATÍN GUIA.

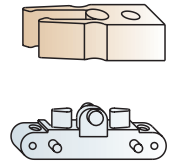
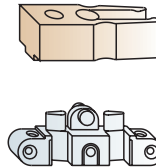
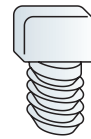

DATOS TÉCNICOS

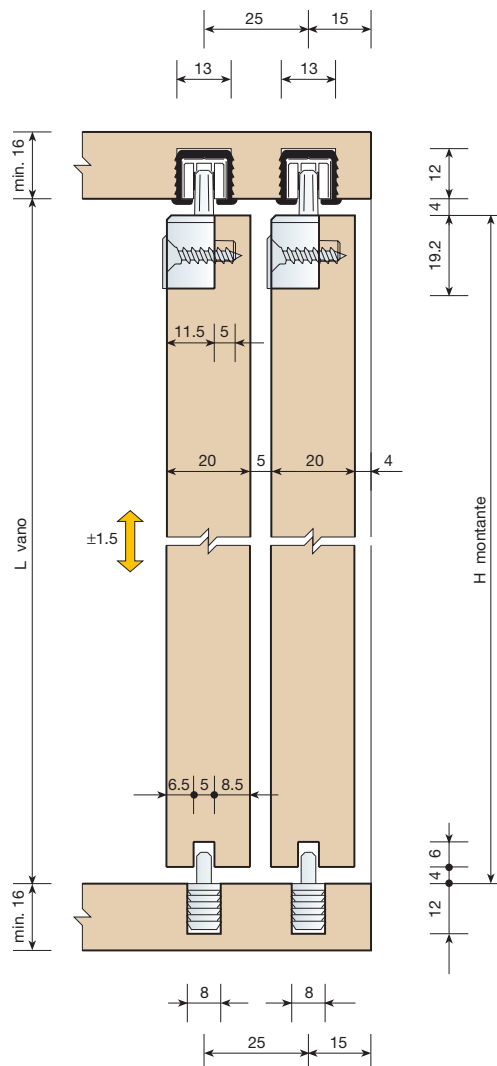
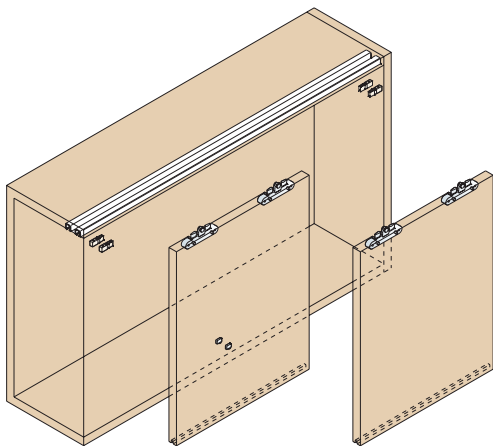

■ DATOS TÉCNICOS

Montaje

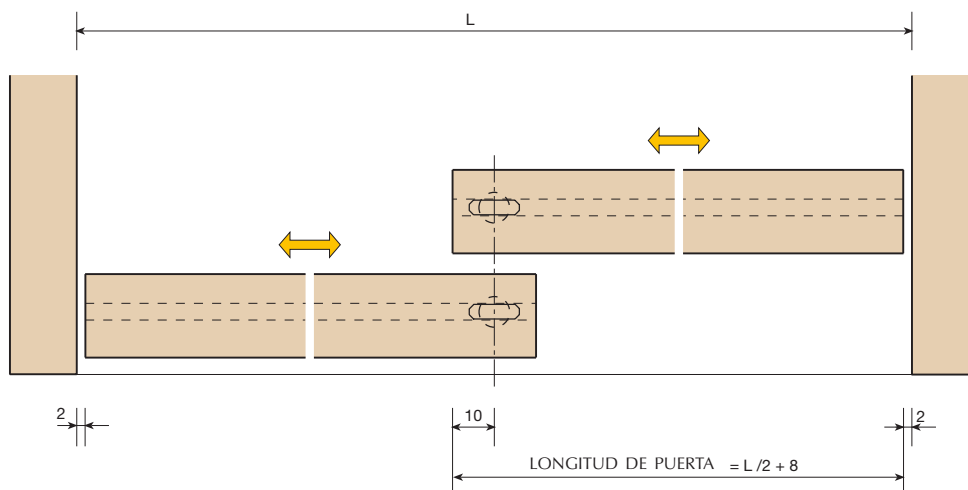
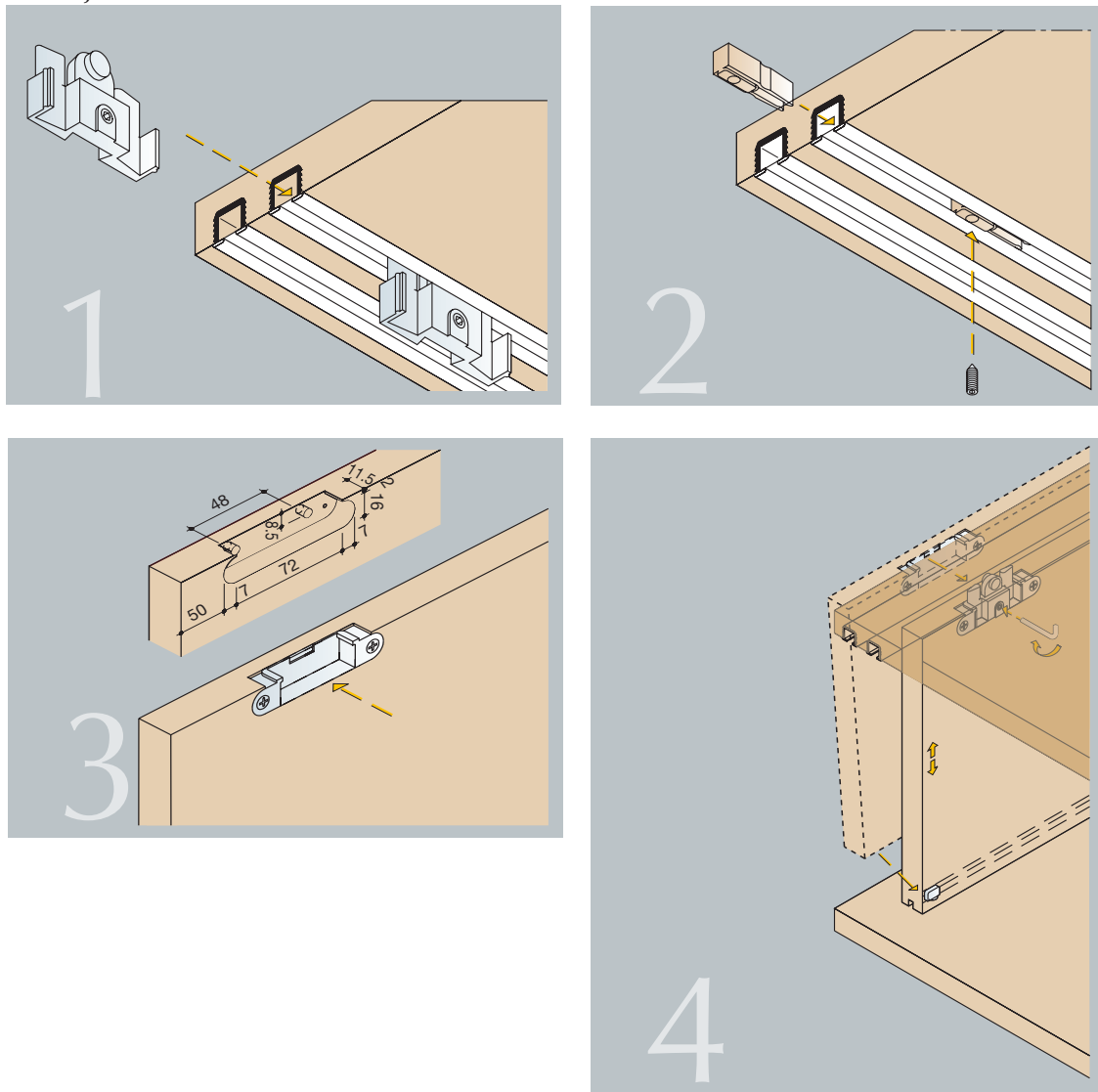

6 "DÚO"

CONJUNTO DE HERRAJES

TAMAÑO DE LA PUERTA		
655-705	703.507.103	1
755-805	703.508.105	
855-905	703.509.100	
955-1005	703.510.102	
1155-1205	703.512.106	

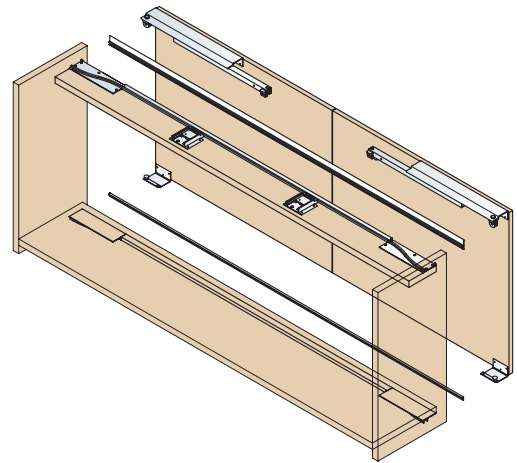

DATOS TÉCNICOS

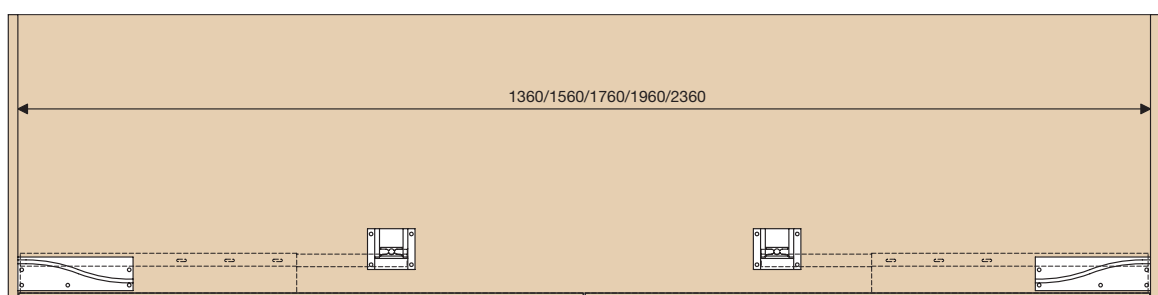
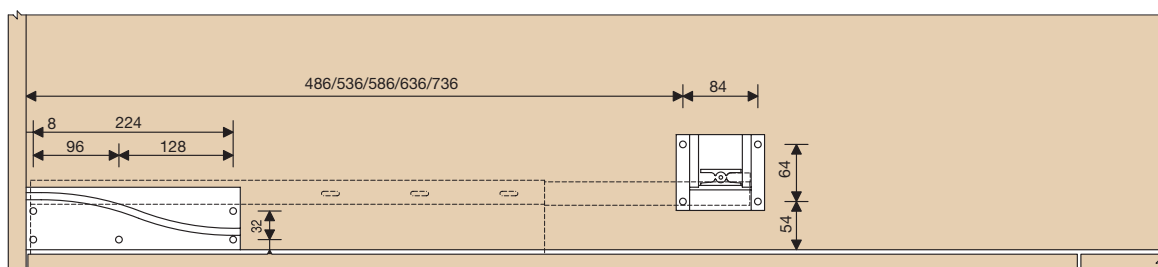
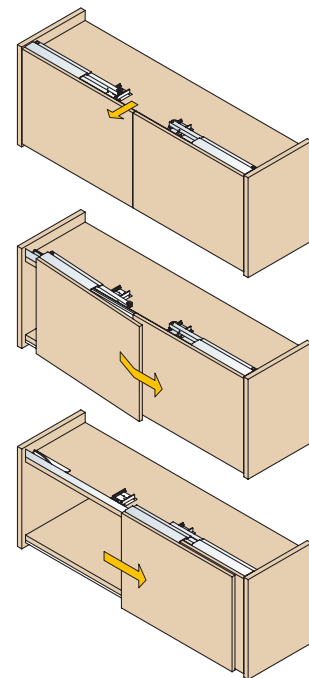
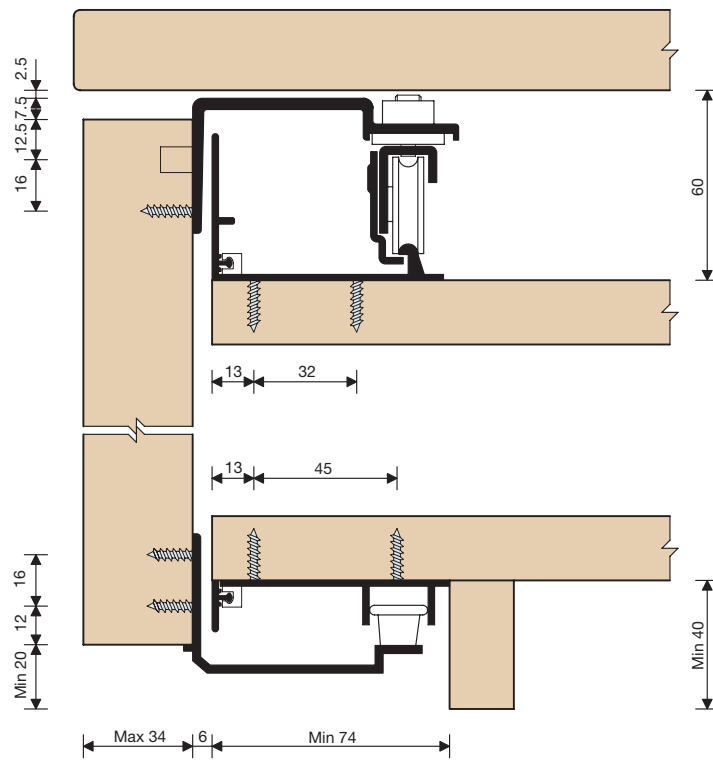

■ DATOS TÉCNICOS

Montaje

