

# Tornillos y tuercas

## ENSAMBLAJES DE UNIÓN

	<i>págs.</i>
<b>1</b> TORNILLOS .....	296
<hr/>	
<b>2</b> TORNILLOS Y TUERCAS .....	297
■ M6 CABEZA DE NYLON .....	297
■ M4 DE ACERO .....	297
■ M6 DE ACERO .....	298
■ 1/4" DE ACERO .....	298



# 1 TORNILLOS

## TORNILLO DE FIJACIÓN CABEZA ALLEN DE 5 MM.

L (MM.)	M6	
30	950.730.045	2.000
35	950.735.041	2.000
40	950.740.044	2.000
45	950.745.040	1.000
50	950.750.043	1.000
55	950.755.046	1.000
60	950.760.042	1.000

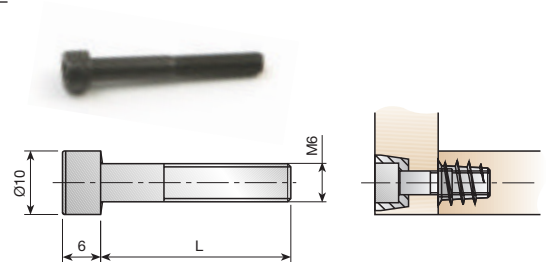

## EMBELLECEDOR DE TORNILLO.

		
LATÓN	580.200.106	500 ó 5.000
ACERO ZINCADO NEGRO	580.200.040	

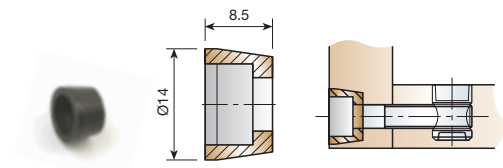

## TORNILLO DE FIJACIÓN EMBELLECEDOR 1/4".

L (MM.)	BICROMATADO	ZINCADO NEGRO	
30	953.130.054	953.130.043	2.000
35	953.135.050	953.135.046	2.000
40	953.140.053	953.140.042	2.000
45	953.145.056	953.145.045	1.000
50	953.150.052	953.150.041	1.000
55	953.155.055	953.155.044	1.000
60	953.160.051	953.160.040	1.000
65	953.165.054	953.165.043	1.000

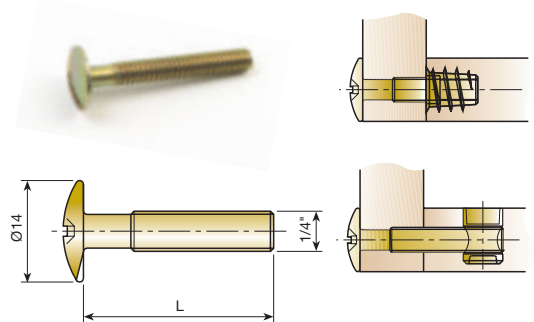

## TAPÓN PARA TORNILLO ALLEN DE 4 MM.

			
BLANCO	RAL 9003	540.500.004	2.000 ó 10.000
NEGRO	RAL 9005	540.500.026	
ROBLE	RAL 1002	540.500.192	

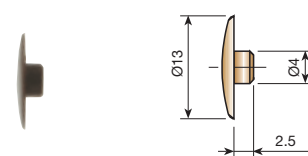

## TORNILLO ENSAMBLAJE 1/4".

L (MM.)	PAVONADO	BICROMATADO	
40	581.940.251	581.940.052	2.000
45	581.945.254	581.945.055	2.000
50	581.950.250	581.950.051	2.000
55	581.955.253	581.955.054	1.000

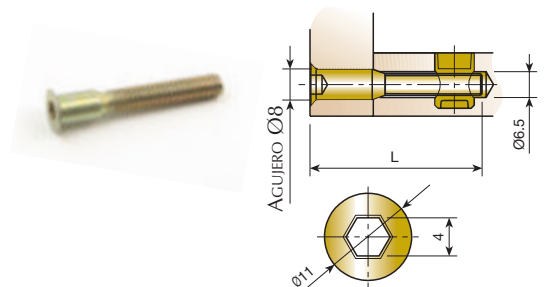

## TUERCA DE ALETAS CON CABEZA.

	1/4"	M6	
BICROMATADO		948.713.054	2.000
ZINCADO	948.613.035		



## TUERCA EMPOTRABLE CILÍNDRICA 1/4" DE ZAMAK

D (MM.)	Ø10		Ø12		
L (MM.)	13 (c=5MM.)	15 (c=6MM.)	13 (c=5MM.)	15 (c=6MM.)	2.000
ZINCADO	940.614.032	940.615.034	940.714.036	940.715.031	



## 2 TORNILLOS Y TUERCAS

### M6 CABEZA DE NYLON

#### TORNILLO ENSAMBLAJE M6 CABEZA NYLON CON RANURA.

L (MM.)	BLANCO RAL 9003	MARRÓN RAL 8016	NEGRO RAL 9005	
28	581.028.000	581.028.011	581.028.022	2.000
30	581.030.004	581.030.015	581.030.026	2.000
34	581.034.005	581.034.016	581.034.020	1.000

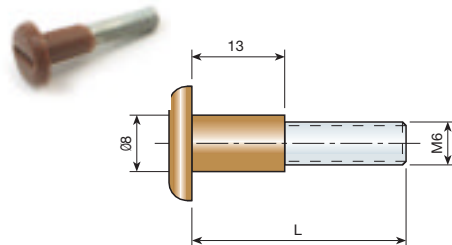

#### TUERCA ENSAMBLAJE M6 CON RANURA.

	BLANCO RAL 9003	MARRÓN RAL 8016	NEGRO RAL 9005	
				1.000 ó 4.000
	943.000.004	943.000.015	943.000.026	

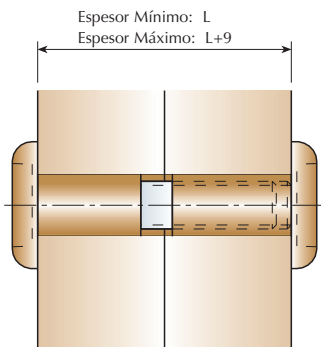
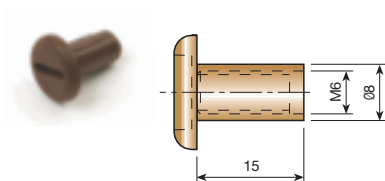

### M4 DE ACERO

#### TUERCA ENSAMBLAJE M4 DE ACERO.

L (MM.)	NIQUELADO	
15	941.915.063	3.000
20	941.920.066	2.500
25	941.925.062	2.000
30	941.930.065	2.000
35	941.935.061	2.000
40	941.940.064	2.000
45	941.945.060	1.000

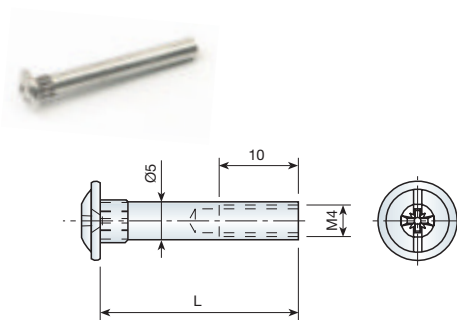

#### TORNILLO ENSAMBLAJE M4 CABEZA ALOMADA.

	NIQUELADO	
	730.510.060	1.000 ó 4.000

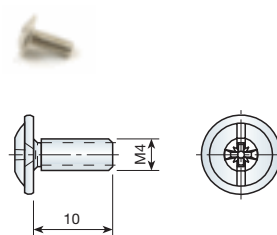
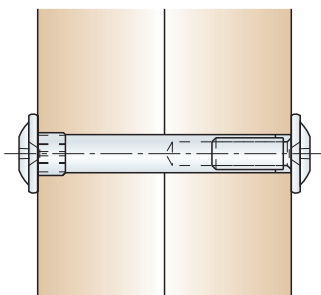

**M6 DE ACERO**

TUERCA ENSAMBLAJE DEL ESPARRAGO M6.

		
NIQUELADO	942.300.063	1.000 ó 5.000

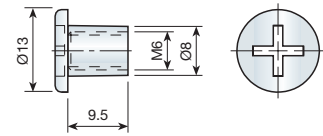

ESPARRAGO M6.

L (MM.)		
30	934.230.102	
35	934.235.105	
45	934.245.104	2.000
50	934.250.100	
60	934.260.106	

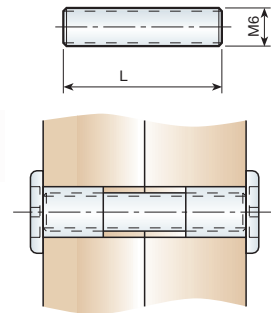

**1/4" DE ACERO**

TORNILLO ENSAMBLAJE 1/4" CABEZA ALOMADA.

		
NIQUELADO	581.200.060	500 ó 4.000

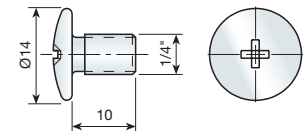

TUERCA ENSAMBLAJE 1/4 DE ACERO.

L (MM.)	ZINCADO	
20	941.620.035	2.000
25	941.625.031	2.000
30	941.630.034	2.000
35	941.635.030	2.000
40	941.640.033	2.000
45	941.645.036	1.000
50	941.650.032	1.000
55	941.655.035	1.000
60	941.660.031	1.000
65	941.665.034	1.000
70	941.670.030	1.000
75	941.675.033	500
80	941.680.036	500
85	941.685.032	500
90	941.690.035	500

