

# Ensamblajes de unión

## ENSAMBLAJES DE UNIÓN

	<i>págs.</i>
<b>1 TORNILLOS ENSAMBLAJE</b> .....	280
■ TAPAS .....	280
■ TORNILLOS .....	280
<hr/>	
<b>2 ENSAMBLAJES DE UNIÓN</b> .....	281
<hr/>	
<b>3 CUERPOS EMPOTRABLES</b> .....	282
<hr/>	
<b>4 TORNILLOS</b> .....	283
<hr/>	
<b>5 TUERCAS</b> .....	284

# 1 TORNILLOS ENSAMBLAJE

## TAPAS

TAPA CORTA Ø35 MM.

			
NIQUELADO		530.500.062	
BLANCO	RAL 9003	530.500.003	1.000
MARRÓN	RAL 8016	530.500.014	
NEGRO	RAL 9005	530.500.025	

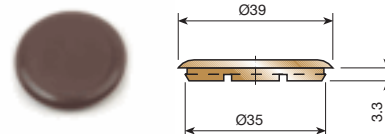

TAPA CON PATILLAS DE ENGANCHE Ø35 MM.

			
BLANCO	RAL 9003	530.700.004	
MARRÓN	RAL 8016	530.700.015	1.000
NEGRO	RAL 9005	530.700.026	

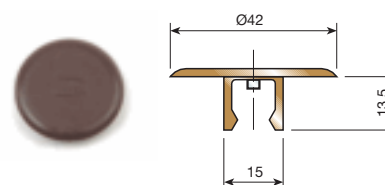

## TORNILLOS

TORNILLO ENSAMBLAJE CABEZA ALMENADA 1/4".

			
ZINCADO		581.532.033	1.000

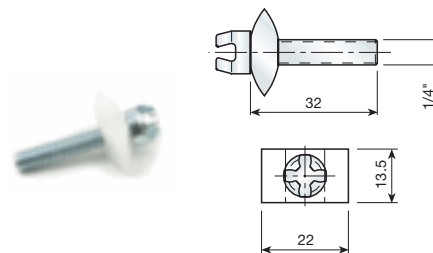

TUERCA ROSCA MADERA SIN CABEZA 1/4".

			
BICROMATADO		947.614.054	2.000

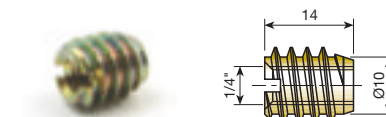

TORNILLO ENSAMBLAJE CABEZA ALMENADA

			
LONGITUD		1/4"	
32		581.432.106	2.000



ARANDELA ESPECIAL CON ALETAS

			
NATURAL		570.000.104	2.000



APRIETE DIRECTO  
POR ATORNILLADOR

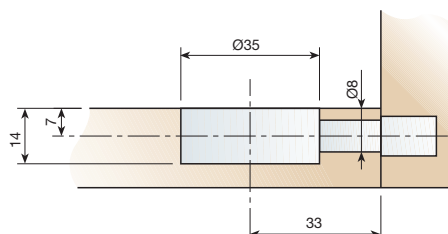
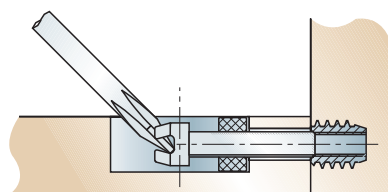

## 2 ENSAMBLAJE DE UNIÓN

### TAPA DE ENSAMBLAJE.

				
BLANCO	RAL 9003	530.300.002		
MARRÓN	RAL 8016	530.300.013	1.000	
NEGRO	RAL 9005	530.300.024		

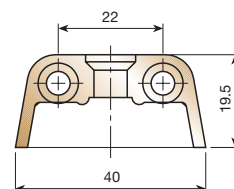

### TORNILLO DE FIJACIÓN 3/16".

				
ZINCADO		952.518.033	500 ó 2.500	

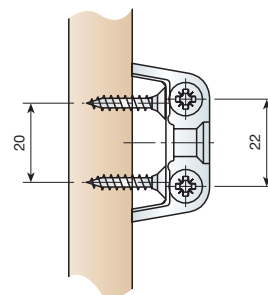

### CUERPO ENSAMBLAJE UNA ROSCA.

				
NATURAL		550.100.106	1.000	



### TIRAFONDO R/CHAPA DE FIJACIÓN Ø5.5 MM.

				
ZINCADO		989.219.033	500 ó 2.000	

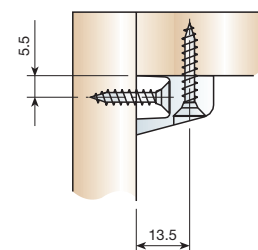

### CUERPO ENSAMBLAJE CON PUNTOS UNA ROSCA.

				
ZINCADO		550.200.033	1.000	



### CONJUNTO CUERPO ENSAMBLAJE

				
BLANCO		550.500.005	1000	

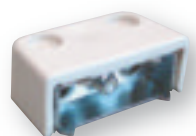

EL CONJUNTO SE COMPONE DE 1 TAPA, 1 CUERPO DE METAL, Y 1 TORNILLO DE FIJACIÓN.  
SE ENTREGA EL CONJUNTO MONTADO.

### 3 CUERPOS EMPOTRABLES

#### TORNILLO ENSAMBLAJE CON PUNTA M6.

L (MM.)	22	25	
ZINCADO	581.322.033	581.325.032	2.000

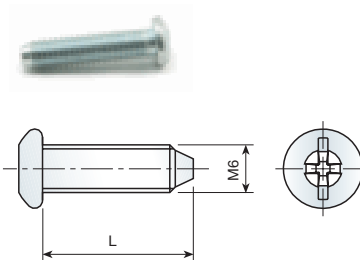

#### CUERPO EMPOTRABLE.

			
BLANCO	RAL 9003	550.000.006	
MARRÓN	RAL 8016	550.000.010	2.000
NEGRO	RAL 9005	550.000.021	

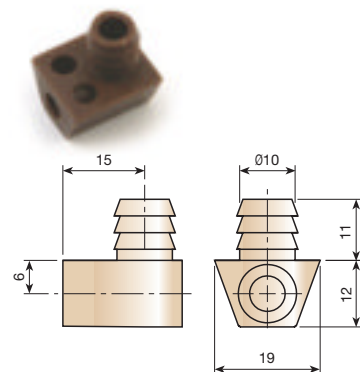

#### TUERCA EMPOTRABLE DE NYLON M6.

			
NATURAL		937.006.103	
MARRÓN	RAL 8016	937.006.011	2.000 ó 10.000
NEGRO	RAL 9005	937.006.022	



#### TUERCA EMPOTRABLE MOLETEADA DE ACERO M6.

L (MM.)	ZINCADO	
14	938.714.103	
16	938.716.100	1.000 ó 5.000
18	938.718.104	
20	938.720.101	

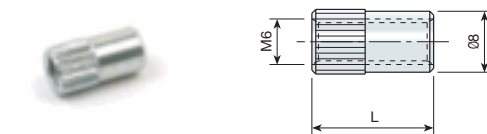

#### CONJUNTO CUERPO EMPOTRABLE

		
BLANCO	550.600.002	2500

EL CONJUNTO SE COMPONE DE 1 CUERPO EMPOTRABLE, 1 TUERCA EMPOTRABLE Y 1 TIRAFONDO .  
SE ENTREGA EL CONJUNTO MONTADO.

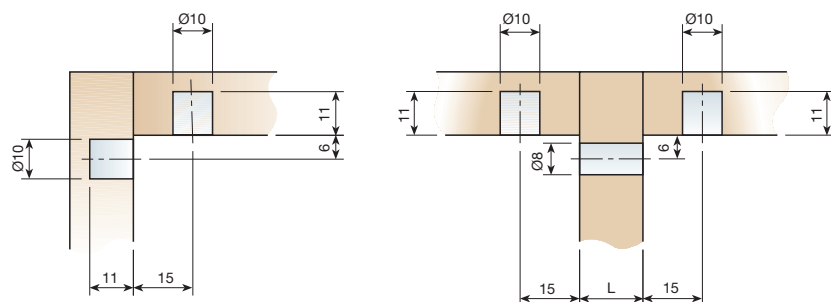

## 4 TORNILLOS

### TORNILLO DE FIJACIÓN CABEZA ALLEN DE 5 MM.

L (MM.)	M6	
30	950.730.045	2.000
35	950.735.041	2.000
40	950.740.044	2.000
45	950.745.040	1.000
50	950.750.043	1.000
55	950.755.046	1.000
60	950.760.042	1.000

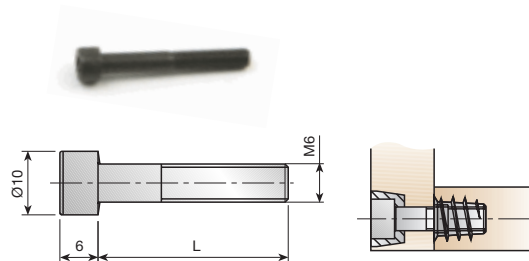

### EMBELLECEDOR DE TORNILLO.

		
LATÓN	580.200.106	500 ó 5.000
ACERO ZINCADO NEGRO	580.200.040	

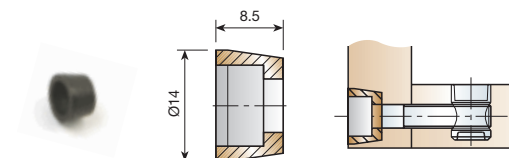

### TORNILLO DE FIJACIÓN EMBELLECEDOR 1/4".

L (MM.)	BICROMATADO	ZINCADO NEGRO	
30	953.130.054	953.130.043	2.000
35	953.135.050	953.135.046	2.000
40	953.140.053	953.140.042	2.000
45	953.145.056	953.145.045	1.000
50	953.150.052	953.150.041	1.000
55	953.155.055	953.155.044	1.000
60	953.160.051	953.160.040	1.000
65	953.165.054	953.165.043	1.000

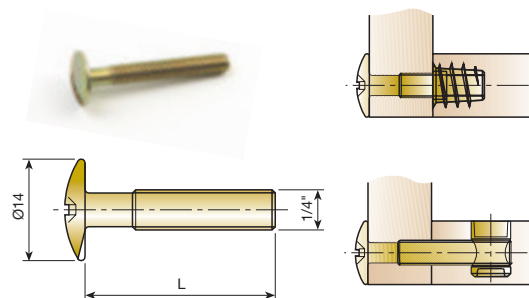

### TAPÓN PARA TORNILLO ALLEN DE 4 MM.

			
BLANCO	RAL 9003	540.500.004	2.000 ó 10.000
NEGRO	RAL 9005	540.500.026	
ROBLE	RAL 1002	540.500.192	

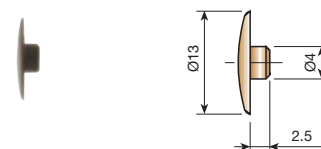

### TORNILLO ENSAMBLAJE 1/4".

L (MM.)	PAVONADO	BICROMATADO	
40	581.940.251	581.940.052	2.000
45	581.945.254	581.945.055	2.000
50	581.950.250	581.950.051	2.000
55	581.955.253	581.955.054	1.000

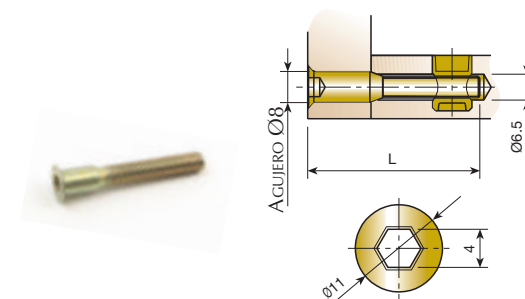

## 5 TUERCAS

### TUERCA EMPOTRABLE CILÍNDRICA 1/4" DE ZAMAK

D (MM.)	Ø10		Ø12		
L (MM.)	13 (c=5MM.)	15 (c=6MM.)	13 (c=5MM.)	15 (c=6MM.)	
	940.614.032	940.615.034	940.714.036	940.715.031	2.000

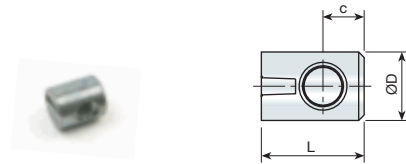

### TUERCA ESTRIADA M8

NATURAL	450.008.101		1.000
---------	-------------	--	-------

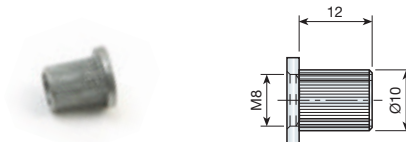

### TUERCA ROSCA MADERA DE ACERO, SIN CABEZA

BICROMATADO					
L (MM.)	Ød (MM.)	ØD (MM.)	1/4"	M6	
10	8	10	947.510.056	947.810.054	2.500
12	8	10	947.512.053	947.812.051	2.000
14	8	10	947.514.050	947.814.055	2.000
18	8	10	947.518.051	947.818.056	2.000
22	8	10	947.522.052	947.822.050	2.000
10	9	12	947.610.053	947.910.051	2.000
12	9	12	947.612.050	947.912.055	2.000
14	9	12	947.614.054	947.914.052	2.000
16	9	12	947.616.051	947.616.051	2.000
18	9	12	947.618.055	947.918.053	2.000

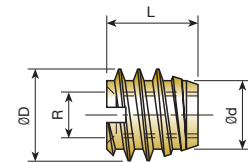

L (MM.)	Ød (MM.)	ØD (MM.)	M8	
22	11	14	948.222.052	1.500

### TUERCA EXPANSIBLE DE LATÓN

M4		2.000 ó 10.000
944.805.105		

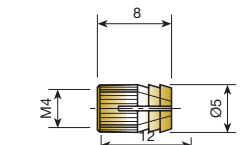

### TUERCA AUTOEXPANSIBLE DE LATÓN M6

M6		5.000
8 Øx 12 MM.	944.112.105	

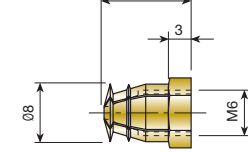

### TUERCA DE ALETAS

1/4"	M6		2.000
BICROMATADO	948.913.055		
ZINCADO	948.813.036		

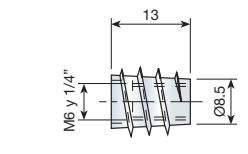

### TUERCA DE ALETAS CON CABEZA.

1/4"	M6	M8		2.000
BICROMATADO	948.713.054			
ZINCADO	948.613.035	948.515.035		

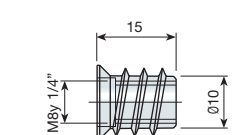
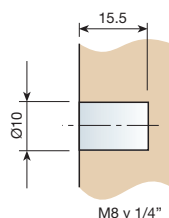
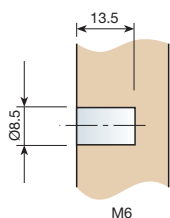
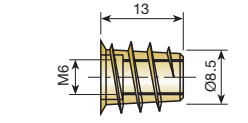

TUERCA EMPOTRABLE DE NYLON M4 PARA Ø8.

			
NATURAL		937.004.106	2.000 ó 10.000
MARRÓN	RAL 8016	937.004.014	

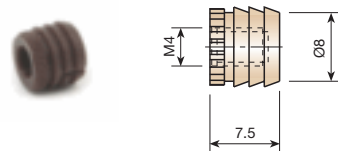

TUERCA EMPOTRABLE DE NYLON PARA Ø10

R	M6	1/4"	
NATURAL	937.006.103	937.014.105	2.000 ó 10.000
MARRÓN	RAL 8016 937.006.011	937.014.013	
NEGRO	RAL 9005 937.006.022	937.014.024	

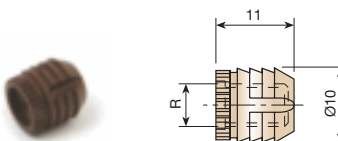

TUERCA EMPOTRABLE DE NYLON PARA Ø11

R	M6	1/4"	
NATURAL	937.106.100	937.114.102	2.000 ó 10.000
MARRÓN	RAL 8016 937.106.015	937.114.010	

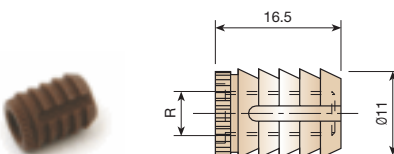

TUERCA EMPOTRABLE DE NYLON M6 PARA Ø10, EN TIRAS.

			
NATURAL		937.406.105	4.800
MARRÓN	RAL 8016	937.406.013	
NEGRO	RAL 9005	937.014.024	

CADA CAJA CONTIENE 200 TIRAS.  
SE OFRECEN TIRAS DE 24 PIEZAS; SU COLOCACIÓN PUEDE SER MANUAL O POR MEDIO DE PISTOLA NEUMÁTICA CON CARGADOR.

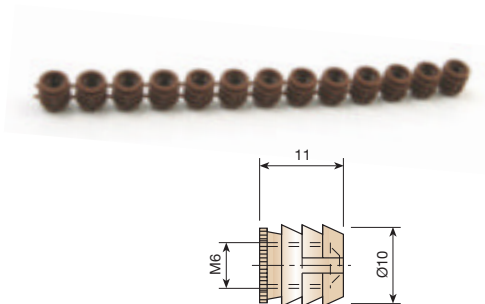

TUERCA EMPOTRABLE MOLETEADA DE ACERO M6

L	16 MM.	18 MM.	
ZINCADO	938.716.100	938.718.104	1.000 ó 5.000

