



Excéntrica Ø25

EXCÉNTRICAS

		<i>págs.</i>
1 EXCÉNTRICA Y TAPAS		254
2 PERNOS		255
3 TUERCAS		256

1 EXCÉNTRICA Y TAPAS

TAPA Ø25 MM.

			
BLANCO	RAL 9003	530.400.006	
MARRÓN	RAL 8016	530.400.010	2.000
NEGRO	RAL 9005	530.400.021	
NIQUELADO		530.400.065	1.000

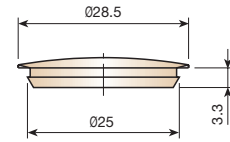

TAPA CON TETONES Ø25 MM.

			
BLANCO	RAL 9003	530.100.001	
MARRÓN	RAL 8016	530.100.012	2.000
NEGRO	RAL 9005	530.100.023	

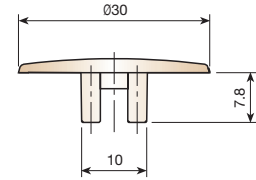

EXCÉNTRICA Ø25 MM.

			
NATURAL		510.011.106	2.000

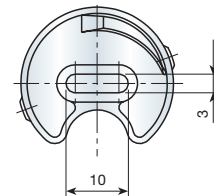
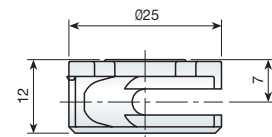

2 PERNOS

PERNO R/MADERA.

DISTANCIA DE TALADRADO 33MM.

ZINCADO

520.839.034

2.000

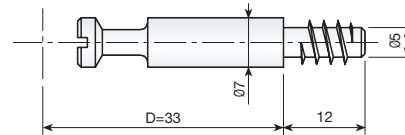
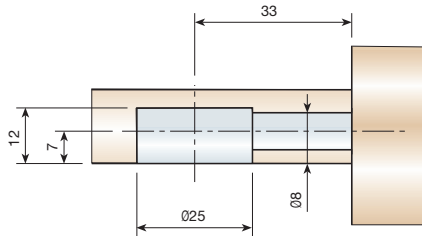

PERNO M6.

DISTANCIA DE TALADRADO 33MM.

ZINCADO

520.735.036

2.000

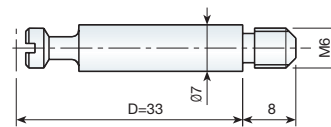
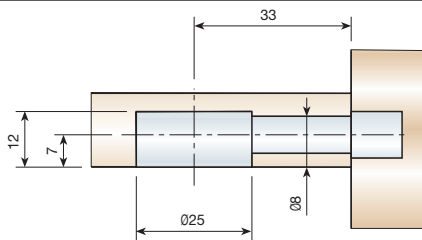

PERNO DOBLE CUELLO.

ZINCADO

522.077.032

1.000

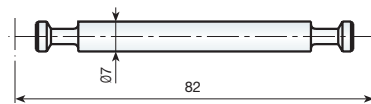
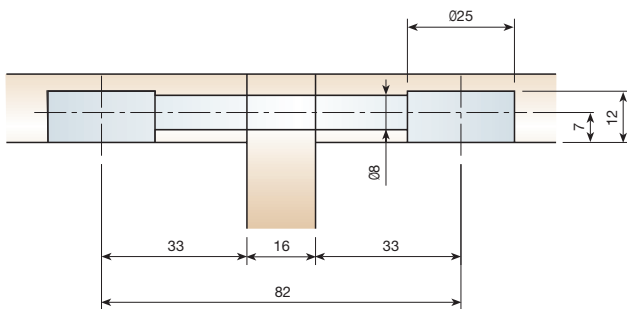

PERNO DOBLE CUELLO A ESCUADRA.

ZINCADO

522.100.036

1.000

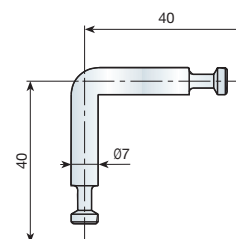
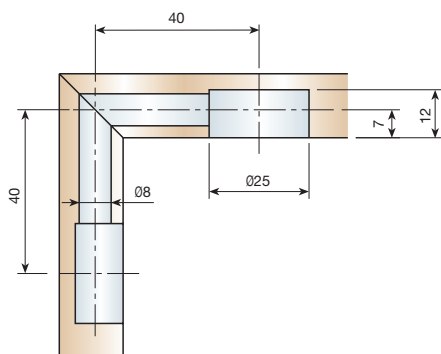

3 TUERCAS

TUERCA ROSCA MADERA DE ACERO, SIN CABEZA

BICROMATADO					
L (MM.)	Ød(MM.)	ØD (MM.)	1/4"	M6	
10	8	10	947.510.056	947.810.054	2.500
12	8	10	947.512.053	947.812.051	2.000
14	8	10	947.514.050	947.814.055	2.000
18	8	10	947.518.051	947.818.056	2.000
22	8	10	947.522.052	947.822.050	2.000
10	9	12	947.610.053	947.910.051	2.000
12	9	12	947.612.050	947.912.055	2.000
14	9	12	947.614.054	947.914.052	2.000
16	9	12	947.616.051	947.616.051	2.000
18	9	12	947.618.055	947.918.053	2.000

L (MM.)	Ød(MM.)	ØD (MM.)	M8	
22	11	14	948.222.052	1.500

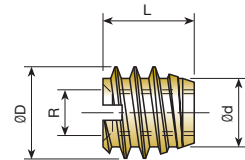

TUERCA EXPANSIBLE DE LATÓN

M4			
944.805.105	2.000 ó 10.000		

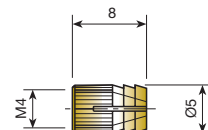

TUERCA AUTOEXPANSIBLE DE LATÓN M6

M6			
8 Øx 12 MM.	944.112.105	5.000	

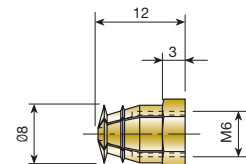

TUERCA DE ALETAS

1/4"		M6	
BICROMATADO	948.913.055	2.000	
ZINCADO	948.813.036		

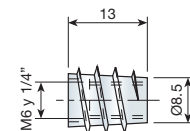

TUERCA DE ALETAS CON CABEZA.

1/4"		M6	M8	
BICROMATADO	948.713.054	2.000		
ZINCADO	948.613.035		948.515.035	

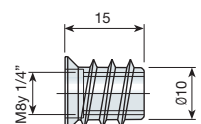
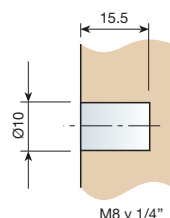
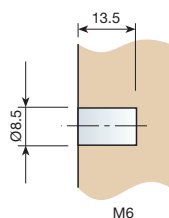
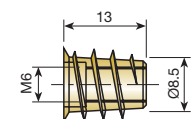

TUERCA EMPOTRABLE DE NYLON M4 PARA Ø8.

			
NATURAL		937.004.106	2.000 ó 10.000
MARRÓN	RAL 8016	937.004.014	

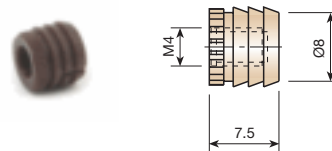

TUERCA EMPOTRABLE DE NYLON PARA Ø10

R	M6	1/4"	
NATURAL	937.006.103	937.014.105	2.000 ó 10.000
MARRÓN	RAL 8016 937.006.011	937.014.013	
NEGRO	RAL 9005 937.006.022	937.014.024	

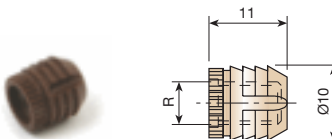

TUERCA EMPOTRABLE DE NYLON PARA Ø11

R	M6	1/4"	
NATURAL	937.106.100	937.114.102	2.000 ó 10.000
MARRÓN	RAL 8016 937.106.015	937.114.010	

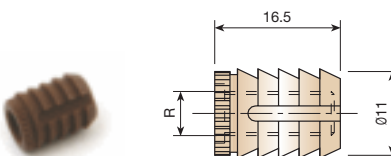

TUERCA EMPOTRABLE DE NYLON M6 PARA Ø10, EN TIRAS.

			
NATURAL		937.406.105	4.800
MARRÓN	RAL 8016	937.406.013	
NEGRO	RAL 9005	937.014.024	

CADA CAJA CONTIENE 200 TIRAS.
SE OFRECEN TIRAS DE 24 PIEZAS; SU COLOCACIÓN PUEDE SER MANUAL O POR MEDIO DE PISTOLA NEUMÁTICA CON CARGADOR.

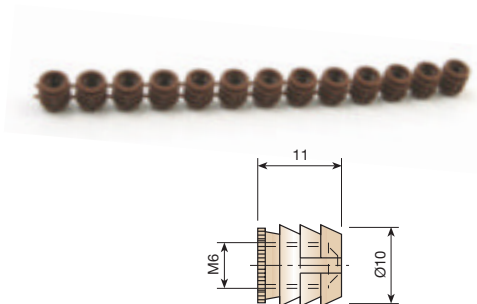

TUERCA EMPOTRABLE MOLETEADA DE ACERO M6

L	16 MM.	18 MM.	
ZINCADO	938.716.100	938.718.104	1.000 ó 5.000

