

Puertas de vitrinas

págs.

1 VITRINAS MECANIZADAS Y PERFILES PARA MECANIZAR .. 670

■ 20X20 RADIO 1	
<i>Vitrinas mecanizadas</i>	670
<i>Perfil para mecanizar</i>	671
■ 20X20 RADIO 6	
<i>Vitrinas mecanizadas</i>	672
<i>Perfil para mecanizar</i>	673
■ 20X20 7.5 VISIBLE	
<i>Vitrinas mecanizadas</i>	674
<i>Perfil para mecanizar</i>	675
■ 35X20 7.5 VISIBLE	
<i>Vitrinas mecanizadas</i>	676
<i>Perfil para mecanizar</i>	677
■ 45X20 7.5 VISIBLE	
<i>Vitrinas mecanizadas</i>	678
<i>Perfil para mecanizar</i>	679
■ 45X20 1.2 VISIBLE	
<i>Vitrinas mecanizadas</i>	680
<i>Perfil para mecanizar</i>	681
■ 45X20X20 VISIBLE	
<i>Vitrinas mecanizadas</i>	682
<i>Perfil para mecanizar</i>	683
■ 50X20X7.5 VISIBLE	
<i>Vitrinas mecanizadas</i>	684
<i>Perfil para mecanizar</i>	685

2 SIN MECANIZACIÓN: "SCREEN KIT" 686

1 VITRINAS MECANIZADAS

20X20 RADIO 1

ESTÁNDAR DE COCINA

VITRINA 20x20 RADIO 1

MÓDULO	DIM. CRISTAL 4MM.	ANOD. PLATA MATE	ANOD. INOXIDABLE	
70x30 (698x298)	671x271	143.130.514	143.130.562	1
70x35 (698x348)	671x321	143.135.510	143.135.565	
70x40 (698x398)	671x371	143.140.513	143.140.561	
70x45 (698x448)	671x421	143.145.516	143.145.564	
70x50 (698x498)	671x471	143.150.512	143.150.560	
70x60 (698x598)	671x571	143.160.511	143.160.566	
90x30 (898x298)	871x271	143.330.515	143.330.563	
90x35 (898x348)	871x321	143.335.511	143.335.566	
90x40 (898x398)	871x371	143.340.514	143.340.562	
90x45 (898x448)	871x421	143.345.510	143.345.565	
90x50 (898x498)	871x471	143.350.513	143.350.561	
90x60 (898x598)	871x571	143.360.512	143.360.560	

SE SUMINISTRAN MECANIZADAS Y DESMONTADAS CON LOS HERRAJES DE UNIÓN Y LOS JUNQUILLOS PARA CRISTAL DE 4MM. EN CAJAS DE 1 PUERTA.

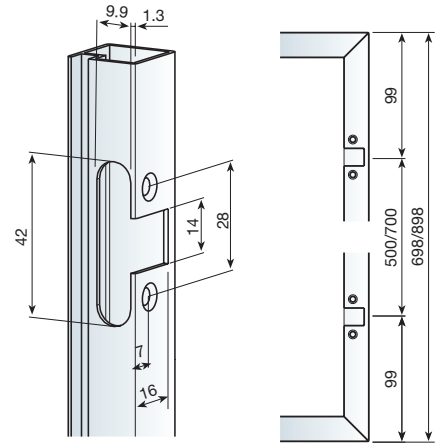
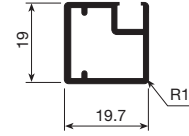

MECANIZADO Y SITUACIÓN DE LAS BISAGRAS

A MEDIDA

VITRINA 20x20 R1 A MEDIDA

PERFIL	BISAGRAS	ANOD. PLATA MATE	ANOD. INOXIDABLE	
20x20R1	0	143.100.510	143.102.565	1
20x20R1	2	143.102.514	143.102.562	
20x20R1	3	143.103.516	143.103.564	
20x20R1	4	143.104.511	143.104.566	

NOTA

LA POSICIÓN DE LAS BISAGRAS ESTÁ DEFINIDA DESDE EL INTERIOR DEL MUEBLE (LADO DE MECANIZACIÓN), A TENER EN CUENTA EN EL CASO DE QUE LA PUERTA SEA ASIMÉTRICA.

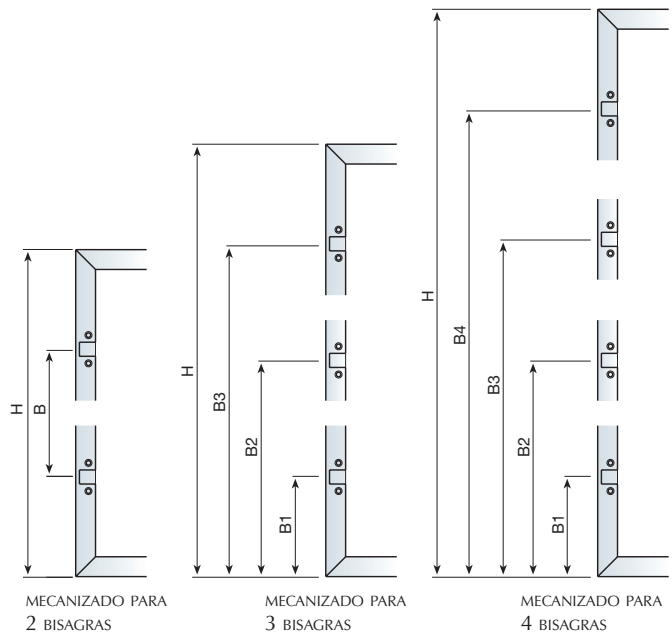

SEGÚN ESPECIFICACIÓN DE CLIENTE

VITRINA 20x20 R1 SEGÚN ESPECIFICACIÓN DE CLIENTE

PERFIL	ANOD. PLATA MATE	ANOD. INOXIDABLE	
20x20R1	143.199.512	143.199.560	1

1 PERFIL PARA MECANIZAR

20X20 RADIO 1

PERFIL PARA MECANIZAR

PERFIL PARA MECANIZAR 20x20 R1

	ANOD. PLATA MATE	ANOD. INOXIDABLE	
	149.060.516	149.060.564	10

BARRAS DE 6M.

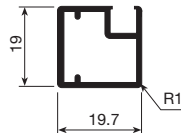

JUNQUILLO PARA CRISTAL DE 4MM.

TRANSPARENTE	753.604.316	50

BARRAS DE 3M. SE SUMINISTRA EN CAJAS DE 50UDS. PARA CRISTAL DE 4MM.



HERRAJES DE UNIÓN

ZINCADO	154.700.033	100

BOLSAS DE 4 ESCUADRA Y 8 TORNILLOS. PARA 100 PUERTAS

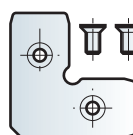

BISAGRA MESUCO 143 RAPID PARA MARCO DE ALUMINIO

APERTURA 110°		
RECTA	306.000.063	50
ACODADA	306.100.060	
SUPERACODADA	306.200.064	

PARA 25 PUERTAS.

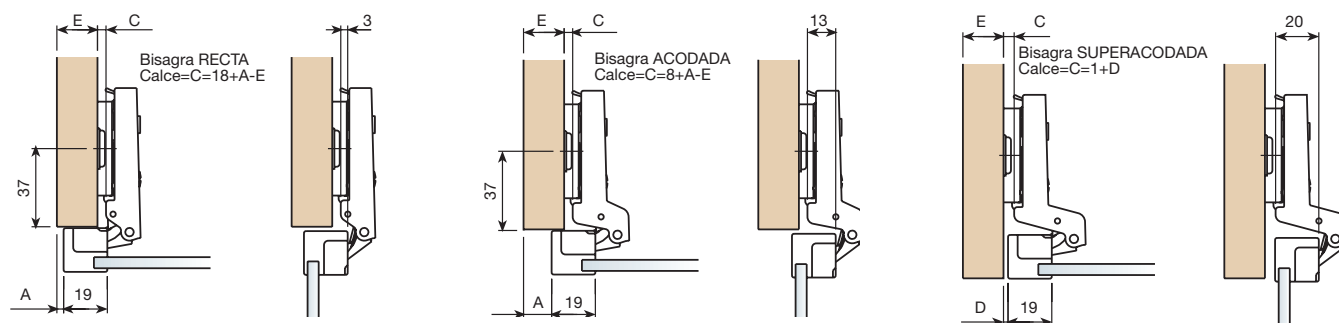
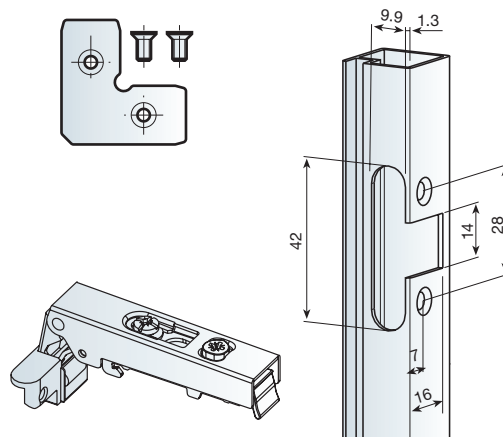

PLACA BASE SISTEMA 32 MONTAJE TIRAFONDOS

CALCE		
2	083.243.134	200
4	083.243.230	

SE SUMINISTRAN EN BOLSAS DE 500 UDS. CADA BOLSA PARA 25 PUERTAS.



1 VITRINAS MECANIZADAS

■ 20X20 RADIO 6

■ ESTÁNDAR DE COCINA

VITRINA 20x20 RADIO 6

MÓDULO	DIM. CRISTAL 4MM.	ANOD. PLATA MATE	ANOD. INOXIDABLE	
70x30 (698x298)	671x271	143.630.513	143.630.561	1
70x35 (698x348)	671x321	143.635.516	143.635.564	
70x40 (698x398)	671x371	143.640.512	143.640.560	
70x45 (698x448)	671x421	143.645.515	143.645.563	
70x50 (698x498)	671x471	143.650.511	143.650.566	
70x60 (698x598)	671x571	143.660.510	143.660.565	
90x30 (898x298)	871x271	143.830.514	143.830.562	
90x35 (898x348)	871x321	143.835.510	143.835.565	
90x40 (898x398)	871x371	143.840.513	143.840.561	
90x45 (898x448)	871x421	143.845.516	143.845.564	
90x50 (898x498)	871x471	143.850.512	143.850.560	
90x60 (898x598)	871x571	143.860.511	143.860.566	

SE SUMINISTRAN MECANIZADAS Y DESMONTADAS CON LOS HERRAJES DE UNIÓN Y LOS JUNQUILLOS PARA CRISTAL DE 4MM. EN CAJAS DE 1 PUERTA.

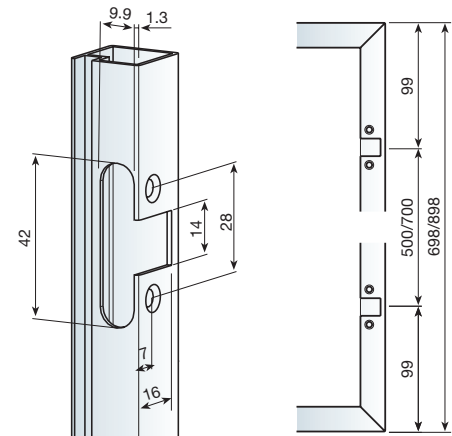
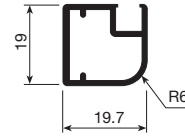

MECANIZADO Y SITUACIÓN DE LAS BISAGRAS

■ A MEDIDA

VITRINA 20x20 R6 A MEDIDA

PERFIL	BISAGRAS	ANOD. PLATA MATE	ANOD. INOXIDABLE	
20x20R6	0	143.600.516	143.600.564	1
20x20R6	2	143.602.513	143.602.561	
20x20R6	3	143.603.515	143.603.563	
20x20R6	4	143.604.510	143.604.565	

NOTA

LA POSICIÓN DE LAS BISAGRAS ESTÁ DEFINIDA DESDE EL INTERIOR DEL MUEBLE (LADO DE MECANIZACIÓN), A TENER EN CUENTA EN EL CASO DE QUE LA PUERTA SEA ASIMÉTRICA.

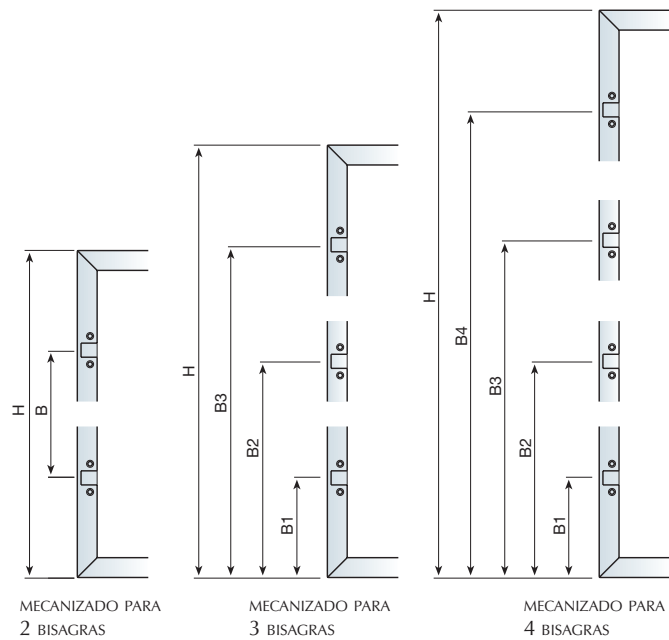

MECANIZADO PARA 2 BISAGRAS

MECANIZADO PARA 3 BISAGRAS

MECANIZADO PARA 4 BISAGRAS

■ SEGÚN ESPECIFICACIÓN DE CLIENTE

VITRINA 20x20 R6 SEGÚN ESPECIFICACIÓN DE CLIENTE

PERFIL	ANOD. PLATA MATE	ANOD. INOXIDABLE	
20x20R6	143.699.511	143.699.566	1

1 PERFIL PARA MECANIZAR

■ 20X20 RADIO 6

■ PERFIL PARA MECANIZAR

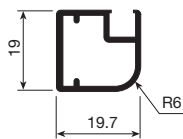

PERFIL PARA MECANIZAR 20x20 R6

ANOD. PLATA MATE	ANOD. INOXIDABLE	
149.160.513	149.160.561	10

BARRAS DE 6M. SE SUMINISTRA EN CAJAS DE 10UDS.

JUNQUILLO PARA CRISTAL DE 4MM.

TRANSPARENTE	753.604.316	
		50

BARRAS DE 3M. SE SUMINISTRA EN CAJAS DE 50UDS. PARA CRISTAL DE 4MM.



HERRAJES DE UNIÓN

ZINCADO	154.700.033	
		100

BOLSAS DE 4 ESCUADRA Y 8 TORNILLOS. SE SUMINISTRA EN CAJAS DE 100UDS. PARA 100 PUERTAS.

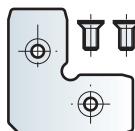

BISAGRA MESUCO 143 RAPID PARA MARCO DE ALUMINIO

APERTURA 110°		
RECTA	306.000.063	
ACODADA	306.100.060	50
SUPERACODADA	306.200.064	

PARA 25 PUERTAS.

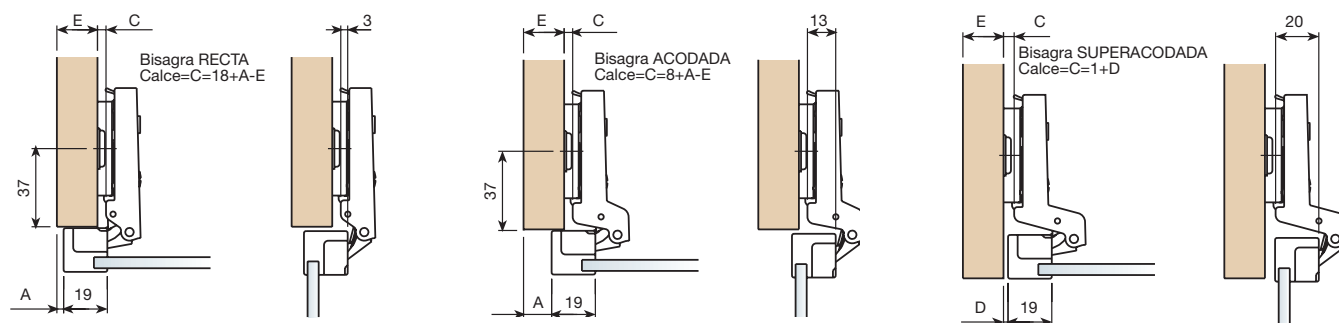
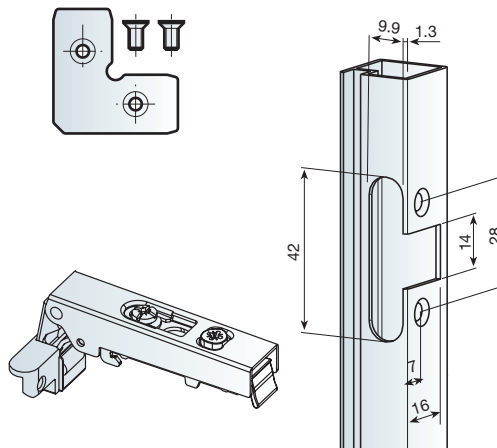

PLACA BASE SISTEMA 32 MONTAJE TIRAFONDOS

CALCE		
2	083.243.134	
4	083.243.230	200

SE SUMINISTRAN EN BOLSAS DE 50 UDS. CADA BOLSA PARA 25 PUERTAS.



1 VITRINAS MECANIZADAS

20X20 RADIO 7.5 VISIBLE

ESTÁNDAR DE COCINA

VITRINA 20x20x7.5 MM. VISTOS

MÓDULO	DIM. CRISTAL 4MM. ANOD. PLATA MATE	ANOD. INOXIDABLE	
70x30 (698x298)	694x294	144.130.512	144.130.560
70x35 (698x348)	694x344	144.135.515	144.135.563
70x40 (698x398)	694x394	144.140.511	144.140.566
70x45 (698x448)	694x444	144.145.514	144.145.562
70x50 (698x498)	694x494	144.150.510	144.150.565
70x60 (698x598)	694x594	144.160.516	144.160.564
90x30 (898x298)	894x294	144.330.513	144.330.561
90x35 (898x348)	894x344	144.335.516	144.335.564
90x40 (898x398)	894x394	144.340.512	144.340.560
90x45 (898x448)	894x444	144.345.515	144.345.563
90x50 (898x498)	894x494	144.350.511	144.350.566
90x60 (898x598)	894x594	144.360.510	144.360.565

SE SUMINISTRAN MECANIZADAS Y DESMONTADAS CON LOS HERRAJES DE UNIÓN Y LOS JUNQUILLOS PARA CRISTAL DE 4MM. EN CAJAS DE 1 PUERTA.

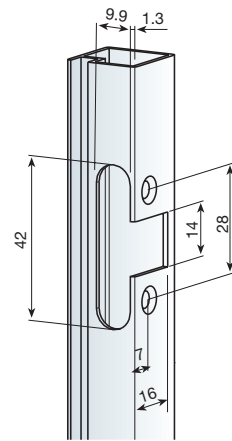
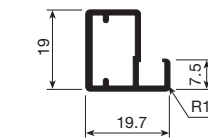

MECANIZADO Y SITUACIÓN DE LAS BISAGRAS

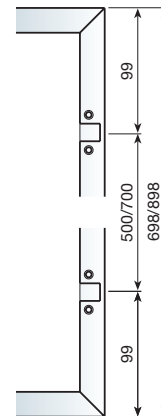

MONTAJE DE LAS PUERTAS CON TRAVESAÑOS

VITRINA CON UN TRAVESAÑO 20x20x7.5 MM.

MÓDULO	DIM. CRISTAL 4MM. ANOD. PLATA MATE	ANOD. INOXIDABLE	
70x30 (698x298)	344x294 2UDS	144.630.511	144.630.566
70x35 (698x348)	344x344 2UDS	144.635.514	144.635.562
70x40 (698x398)	344x394 2UDS	144.640.510	144.640.565
70x45 (698x448)	344x444 2UDS	144.645.513	144.645.561
70x50 (698x498)	344x494 2UDS	144.650.516	144.650.564
70x60 (698x598)	344x594 2UDS	144.660.515	144.660.563
90x30 (898x298)	444x294 2UDS	144.830.512	144.830.560
90x35 (898x348)	444x344 2UDS	144.835.515	144.835.563
90x40 (898x398)	444x394 2UDS	144.840.511	144.840.566
90x45 (898x448)	444x444 2UDS	144.845.514	144.845.562
90x50 (898x498)	444x494 2UDS	144.850.510	144.850.565
90x60 (898x598)	444x594 2UDS	144.860.516	144.860.564

VITRINA CON DOS TRAVESAÑOS 20x20x7.5 MM

MÓDULO	DIM. CRISTAL 4MM. ANOD. PLATA MATE	ANOD. INOXIDABLE	
228x294 3UDS	145.130.510	145.130.565	
228x344 3UDS	145.135.513	145.135.561	
228x394 3UDS	145.140.516	145.140.564	
228x444 3UDS	145.145.512	145.145.560	
228x494 3UDS	145.150.515	145.150.563	
228x594 3UDS	145.160.514	145.160.562	
294x294 3UDS	145.330.511	145.330.566	
294x344 3UDS	145.335.514	145.335.562	
294x394 3UDS	145.340.510	145.340.565	
294x444 3UDS	145.345.513	145.345.561	
294x494 3UDS	145.350.516	145.350.564	
294x594 3UDS	145.360.515	145.360.563	

SE SUMINISTRAN MECANIZADAS Y DESMONTADAS CON LOS HERRAJES DE UNIÓN Y LOS JUNQUILLOS PARA CRISTAL DE 4MM. EN CAJAS DE 1 PUERTA.

A MEDIDA

VITRINA 20x20x7.5 MM. A MEDIDA

PERFIL	BISAGRAS	ANOD. PLATA MATE	ANOD. INOXIDABLE	PLATA BRILLO
20x20x7.5	0	144.100.515	144.100.563	144.100.106
20x20x7.5	2	144.102.512	144.102.560	144.102.103
20x20x7.5	3	144.103.514	144.103.562	144.103.105
20x20x7.5	4	144.104.516	144.104.564	144.104.100

NOTA

LA POSICIÓN DE LAS BISAGRAS ESTÁ DEFINIDA DESDE EL INTERIOR DEL MUEBLE (LADO DE MECANIZACIÓN), A TENER EN CUENTA EN EL CASO DE QUE LA PUERTA SEA ASIMÉTRICA.

SEGÚN ESPECIFICACIÓN DE CLIENTE

VITRINA 20x20x7.5 MM. SEGÚN ESPECIFICACIÓN DE CLIENTE

PERFIL	ANOD. PLATA MATE	ANOD. INOXIDABLE	PLATA BRILLO
20x20x7.5	144.199.510	144.199.565	144.199.101

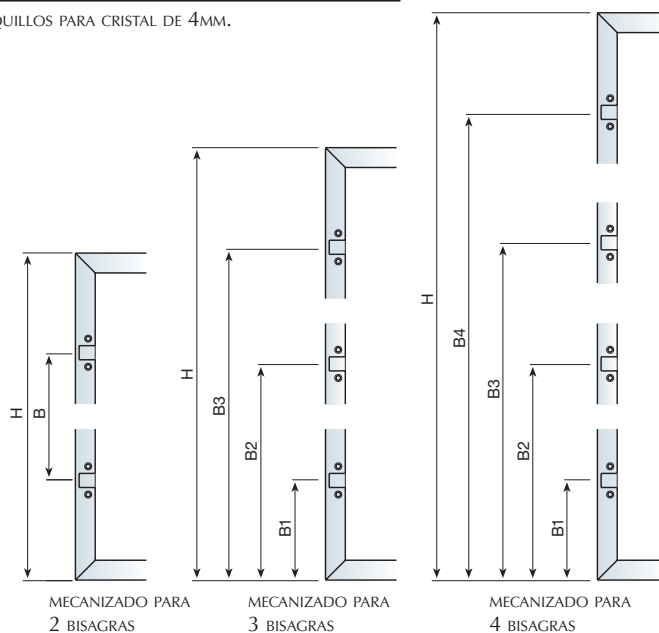

MECANIZADO PARA 2 BISAGRAS

MECANIZADO PARA 3 BISAGRAS

MECANIZADO PARA 4 BISAGRAS

1 PERFIL PARA MECANIZAR

20X20 7.5 VISIBLE

PERFIL PARA MECANIZAR

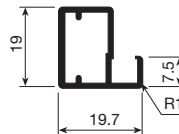

PERFIL PARA MECANIZAR 20x20x7.5 MM

	ANOD. PLATA MATE	ANOD. INOXIDABLE	PLATA BRILLO	
	149.260.510	149.260.565	149.260.101	10

BARRAS DE 6M. SE SUMINISTRA EN CAJAS DE 10UDS.

JUNQUILLO PARA CRISTAL DE 4MM.

		
TRANSPARENTE	753.604.316	50

BARRAS DE 3M. SE SUMINISTRA EN CAJAS DE 50UDS. PARA CRISTAL DE 4MM.



HERRAJES DE UNIÓN

		
ZINCADO	154.700.033	100

BOLSAS DE 4 ESCUADRA Y 8 TORNILLOS. SE SUMINISTRA EN CAJAS DE 100UDS. PARA 100 PUERTAS

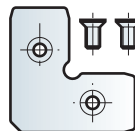

BISAGRA MESUCO 143 RAPID PARA MARCO DE ALUMINIO

APERTURA 110°		
RECTA	306.000.063	50
ACODADA	306.100.060	
SUPERACODADA	306.200.064	

PARA 25 PUERTAS.

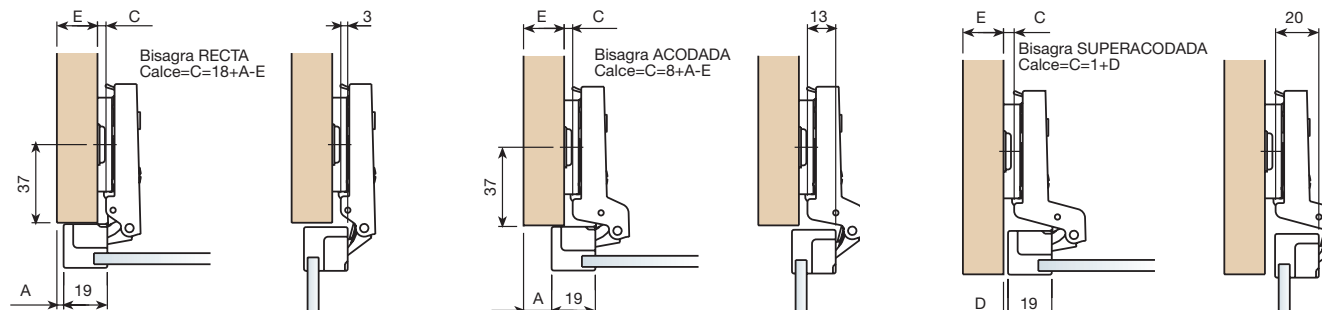
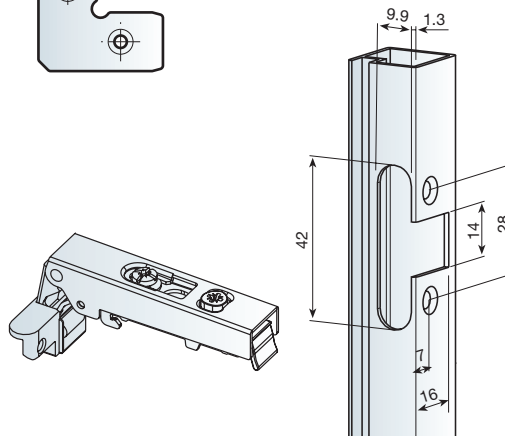

PLACA BASE SISTEMA 32 MONTAJE TIRAFONDOS

CALCE		
2	083.243.134	200
4	083.243.230	

SE SUMINISTRAN EN BOLSAS DE 50 UDS. CADA BOLSA PARA 2 PUERTAS.



1 VITRINAS MECANIZADAS

■ 35X20 7.5 VISIBLE

■ ESTÁNDAR DE COCINA

VITRINA 35x20x7.5 MM. VISTOS

MÓDULO	DIM. CRISTAL 4MM.	ANOD. PLATA MATE	ANOD. INOXIDABLE
70x30 (698x298)	694x294	145.630.516	145.630.564
70x35 (698x348)	694x344	145.635.512	145.635.560
70x40 (698x398)	694x394	145.640.515	145.640.563
70x45 (698x448)	694x444	145.645.511	145.645.566
70x50 (698x498)	694x494	145.650.514	145.650.562
70x60 (698x598)	694x594	145.660.513	145.660.561
90x30 (898x298)	894x294	145.830.510	145.830.565
90x35 (898x348)	894x344	145.835.513	145.835.561
90x40 (898x398)	894x394	145.840.516	145.840.564
90x45 (898x448)	894x444	145.845.512	145.845.560
90x50 (898x498)	894x494	145.850.515	145.850.563
90x60 (898x598)	894x594	145.860.514	145.860.562

SE SUMISTRAN MECANIZADAS Y DESMONTADAS CON LOS HERRAJES DE UNIÓN Y LOS JUNQUILLOS PARA CRISTAL DE 4MM. EN CAJAS DE 1 PUERTA.

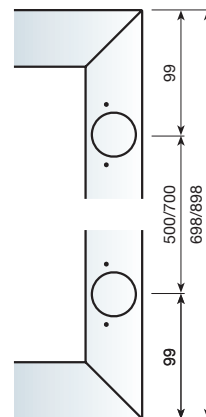
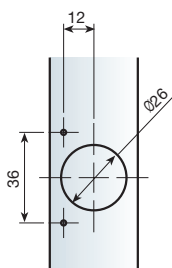
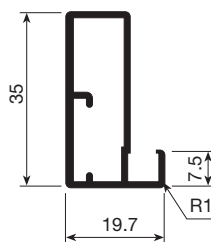

MECANIZADO Y SITUACIÓN DE LAS BISAGRAS

MONTAJE DE LAS PUERTAS CON TRAVESAÑOS

VITRINA CON UN TRAVESAÑO 35x20x7.5 MM.

MÓDULO	DIM. CRISTAL 4MM.	ANOD. PLATA MATE	ANOD. INOXIDABLE
70x30 (698x298)	344x294 2UDS	146.130.515	146.130.563
70x35 (698x348)	344x344 2UDS	146.135.511	146.135.566
70x40 (698x398)	344x394 2UDS	146.140.514	146.140.562
70x45 (698x448)	344x444 2UDS	146.145.510	146.145.565
70x50 (698x498)	344x494 2UDS	146.150.513	146.150.561
70x60 (698x598)	344x594 2UDS	146.160.512	146.160.560
90x30 (898x298)	444x294 2UDS	146.330.516	146.330.564
90x35 (898x348)	444x344 2UDS	146.335.512	146.335.560
90x40 (898x398)	444x394 2UDS	146.340.515	146.340.563
90x45 (898x448)	444x444 2UDS	146.345.511	146.345.566
90x50 (898x498)	444x494 2UDS	146.350.514	146.350.562
90x60 (898x598)	444x594 2UDS	146.360.513	146.360.561

VITRINA CON DOS TRAVESAÑOS 35x20x7.5 MM

DIM. CRISTAL 4MM.	ANOD. PLATA MATE	ANOD. INOXIDABLE
228x294 3UDS	146.630.514	146.630.562
228x344 3UDS	146.635.510	146.635.565
228x394 3UDS	146.640.513	146.640.561
228x444 3UDS	146.645.516	146.645.564
228x494 3UDS	146.650.512	146.650.560
228x594 3UDS	146.660.511	146.660.566
294x294 3UDS	146.830.515	146.830.563
294x344 3UDS	146.835.511	146.835.566
294x394 3UDS	146.840.514	146.840.562
294x444 3UDS	146.845.510	146.845.565
294x494 3UDS	146.850.513	146.850.561
294x594 3UDS	146.860.512	146.860.560

SE SUMISTRAN MECANIZADAS Y DESMONTADAS CON LOS HERRAJES DE UNIÓN Y LOS JUNQUILLOS PARA CRISTAL DE 4MM. EN CAJAS DE 1 PUERTA.

■ A MEDIDA

VITRINA 35x20x7.5 MM. A MEDIDA

PERFIL	BISAGRAS	ANOD. PLATA MATE	ANOD. INOXIDABLE
35x20x7.5	0	145.600.512	145.600.560
35x20x7.5	2	145.602.516	145.602.564
35x20x7.5	3	145.603.511	145.603.566
35x20x7.5	4	145.604.513	145.604.561

NOTA

LA POSICIÓN DE LAS BISAGRAS ESTÁ DEFINIDA DESDE EL INTERIOR DEL MUEBLE (LADO DE MECANIZACIÓN), A TENER EN CUENTA EN EL CASO DE QUE LA PUERTA SEA ASIMÉTRICA.

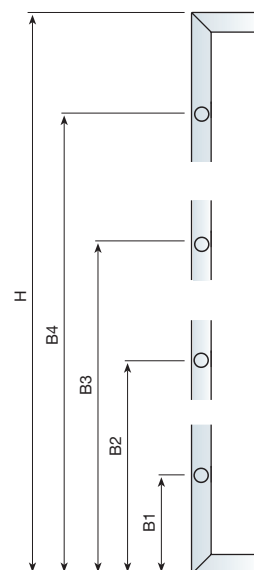
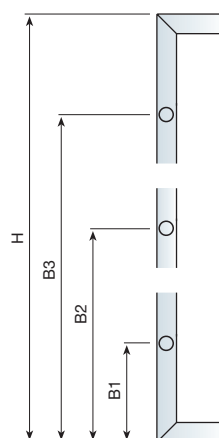
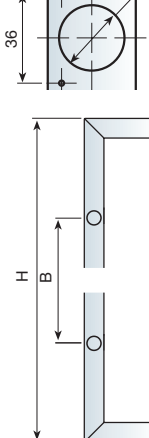
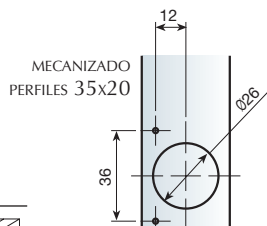

MECANIZADO PARA 2 BISAGRAS

MECANIZADO PARA 3 BISAGRAS

MECANIZADO PARA 4 BISAGRAS

■ SEGÚN ESPECIFICACIÓN DE CLIENTE

VITRINA 35x20x7.5 MM. SEGÚN ESPECIFICACIÓN DE CLIENTE

PERFIL	ANOD. PLATA MATE	ANOD. INOXIDABLE
30x20x7.5	145.699.514	145.699.562

1 PERFIL PARA MECANIZAR

■ 35X20 7.5 VISIBLE

■ PERFIL PARA MECANIZAR

PERFIL PARA MECANIZAR 30x20x7.5 MM

	ANOD. PLATA MATE	ANOD. INOXIDABLE	
	149.360.514	149.360.562	10

BARRAS DE 6M. SE SUMINISTRA EN CAJAS DE 10UDS.

JUNQUILLO PARA CRISTAL DE 4MM.

		
TRANSPARENTE	753.604.316	50

BARRAS DE 3M. SE SUMINISTRA EN CAJAS DE 50UDS. PARA CRISTAL DE 4MM.

HERRAJES DE UNIÓN

		
ZINCADO	154.700.033	100

BOLSAS DE 4 ESCUADRA Y 8 TORNILLOS. SE SUMINISTRA EN CAJAS DE 100UDS. PARA 100 PUERTAS

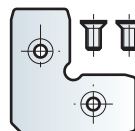
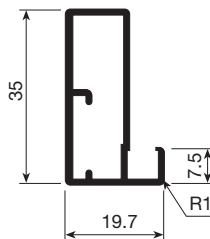

1 VITRINAS MECANIZADAS

45X20 7.5 VISIBLE

ESTÁNDAR DE COCINA

VITRINA 45X20X7.5 MM. VISTOS

MÓDULO	DIM. CRISTAL 4MM.	ANOD. PLATA MATE	ANOD. INOXIDABLE
70x30 (698x298)	694x294	147.630.512	147.630.560
70x35 (698x348)	694x344	147.635.515	147.635.563
70x40 (698x398)	694x394	147.640.511	147.640.566
70x45 (698x448)	694x444	147.645.514	147.645.562
70x50 (698x498)	694x494	147.650.510	147.650.565
70x60 (698x598)	694x594	147.660.516	147.660.564
90x30 (898x298)	894x294	147.830.513	147.830.561
90x35 (898x348)	894x344	147.835.516	147.835.564
90x40 (898x398)	894x394	147.840.512	147.840.560
90x45 (898x448)	894x444	147.845.515	147.845.563
90x50 (898x498)	894x494	147.850.511	147.850.566
90x60 (898x598)	894x594	147.860.510	147.860.565



1

SE SUMISTRAN MECANIZADAS Y DESMONTADAS CON LOS HERRAJES DE UNIÓN Y LOS JUNQUILLOS PARA CRISTAL DE 4MM. EN CAJAS DE 1 PUERTA.

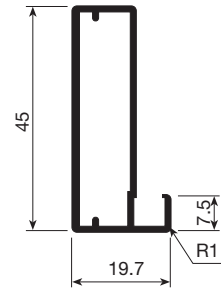

MECANIZADO Y SITUACIÓN DE LAS BISAGRAS

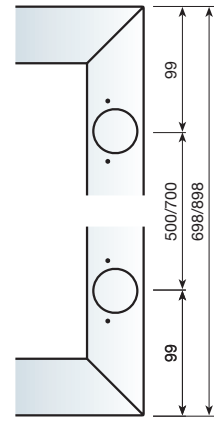

MONTAJE DE LAS PUERTAS CON TRAVESAÑOS

VITRINA CON UN TRAVESAÑO 45X20X7.5 MM.

MÓDULO	DIM. CRISTAL 4MM.	ANOD. PLATA MATE	ANOD. INOXIDABLE
70x30 (698x298)	344x294 2UDS	148.130.511	148.130.566
70x35 (698x348)	344x344 2UDS	148.135.514	148.135.562
70x40 (698x398)	344x394 2UDS	148.140.510	148.140.565
70x45 (698x448)	344x444 2UDS	148.145.513	148.145.561
70x50 (698x498)	344x494 2UDS	148.150.516	148.150.564
70x60 (698x598)	344x594 2UDS	148.160.515	148.160.563
90x30 (898x298)	444x294 2UDS	148.330.512	148.330.560
90x35 (898x348)	444x344 2UDS	148.335.515	148.335.563
90x40 (898x398)	444x394 2UDS	148.340.511	148.340.566
90x45 (898x448)	444x444 2UDS	148.345.514	148.345.562
90x50 (898x498)	444x494 2UDS	148.350.510	148.350.565
90x60 (898x598)	444x594 2UDS	148.360.516	148.360.564

VITRINA CON DOS TRAVESAÑOS 45X20X7.5 MM

MÓDULO	DIM. CRISTAL 4MM.	ANOD. PLATA MATE	ANOD. INOXIDABLE
228x294 3UDS	228x294 3UDS	148.630.510	148.630.565
228x344 3UDS	228x344 3UDS	148.635.513	148.635.561
228x394 3UDS	228x394 3UDS	148.640.516	148.640.564
228x444 3UDS	228x444 3UDS	148.645.512	148.645.560
228x494 3UDS	228x494 3UDS	148.650.515	148.650.563
228x594 3UDS	228x594 3UDS	148.660.514	148.660.562
294x294 3UDS	294x294 3UDS	148.830.511	148.830.566
294x344 3UDS	294x344 3UDS	148.835.514	148.835.562
294x394 3UDS	294x394 3UDS	148.840.510	148.840.565
294x444 3UDS	294x444 3UDS	148.845.513	148.845.561
294x494 3UDS	294x494 3UDS	148.850.516	148.850.564
294x594 3UDS	294x594 3UDS	148.860.515	148.860.563



1

SE SUMISTRAN MECANIZADAS Y DESMONTADAS CON LOS HERRAJES DE UNIÓN Y LOS JUNQUILLOS PARA CRISTAL DE 4MM. EN CAJAS DE 1 PUERTA.

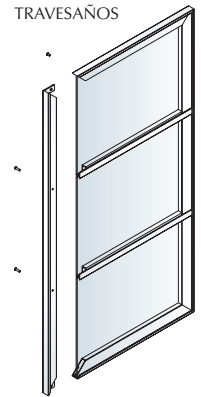

A MEDIDA

VITRINA 45X20X7.5 MM. A MEDIDA

PERFIL	BISAGRAS	ANOD. PLATA MATE	ANOD. INOXIDABLE
45x20x7.5	0	147.600.515	147.600.563
45x20x7.5	2	147.602.512	147.602.560
45x20x7.5	3	147.603.514	147.603.562
45x20x7.5	4	147.604.516	147.604.564



1

NOTA

LA POSICIÓN DE LAS BISAGRAS ESTÁ DEFINIDA DESDE EL INTERIOR DEL MUEBLE (LADO DE MECANIZACIÓN), A TENER EN CUENTA EN EL CASO DE QUE LA PUERTA SEA ASIMÉTRICA.

SEGÚN ESPECIFICACIÓN DE CLIENTE

VITRINA 45X20X7.5 MM. SEGÚN ESPECIFICACIÓN DE CLIENTE

PERFIL	ANOD. PLATA MATE	ANOD. INOXIDABLE	PLATA BRILLO
45x20x7.5	147.699.510	147.699.565	147.699.101



1

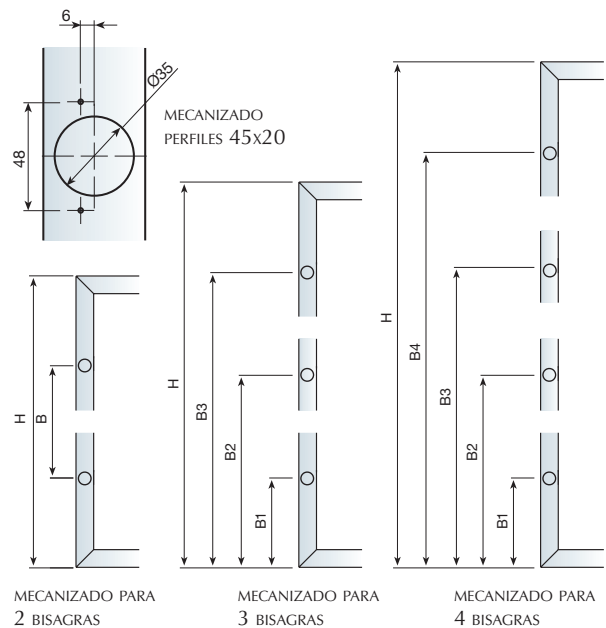

MECANIZADO PARA 2 BISAGRAS

MECANIZADO PARA 3 BISAGRAS

MECANIZADO PARA 4 BISAGRAS

1 PERFIL PARA MECANIZAR

■ 45X20 7.5 VISIBLE

■ PERFIL PARA MECANIZAR

PERFIL PARA MECANIZAR 45x20x7.5 MM

ANOD. PLATA MATE	ANOD. INOXIDABLE	PLATA BRILLO	NEGRO	
149.560.515	149.560.563	149.560.106	149.560.541	10

BARRAS DE 6M. SE SUMINISTRA EN CAJAS DE 10UDS.

JUNQUILLO PARA CRISTAL DE 4MM.

TRANSPARENTE	753.604.316	
		50

BARRAS DE 3M. SE SUMINISTRA EN CAJAS DE 50UDS. PARA CRISTAL DE 4MM.

HERRAJES DE UNIÓN

ZINCADO	154.800.030	
		100

BOLSAS DE 4 ESCUADRA Y 8 TORNILLOS. SE SUMINISTRA EN CAJAS DE 100UDS. PARA 100 PUERTAS

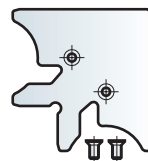
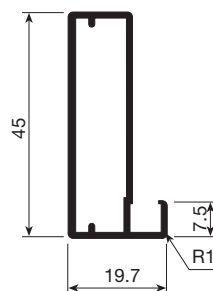

1 VITRINAS MECANIZADAS

45X20 1.2 VISIBLE

ESTÁNDAR DE COCINA

VITRINA 45x20x1.2 PARA CRISTAL ADHERIDO

MÓDULO	DIM. CRISTAL 4MM.	ANOD. PLATA MATE	ANOD. INOXIDABLE	
70x30 (698x298)	695x295	147.130.513	147.130.561	1
70x35 (698x348)	695x345	147.135.516	147.135.564	
70x40 (698x398)	695x395	147.140.512	147.140.560	
70x45 (698x448)	695x445	147.145.515	147.145.563	
70x50 (698x498)	695x495	147.150.511	147.150.566	
70x60 (698x598)	695x595	147.160.510	147.160.565	
90x30 (898x298)	895x295	147.330.514	147.330.562	
90x35 (898x348)	895x345	147.335.510	147.335.565	
90x40 (898x398)	895x395	147.340.513	147.340.561	
90x45 (898x448)	895x445	147.345.516	147.345.564	
90x50 (898x498)	895x495	147.350.512	147.350.560	
90x60 (898x598)	895x595	147.360.511	147.360.566	

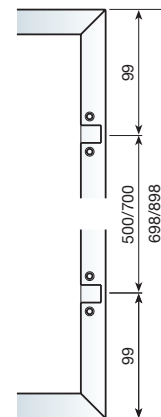
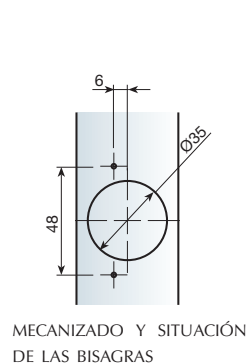
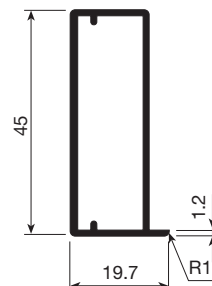

SE SUMINISTRAN MECANIZADAS Y DESMONTADAS CON LOS HERRAJES DE UNIÓN Y LOS JUNQUILLOS PARA CRISTAL DE 4MM. EN CAJAS DE 1 PUERTA.

A MEDIDA

VITRINA 45x20x1.2 A MEDIDA

PERFIL	BISAGRAS	ANOD. PLATA MATE	ANOD. INOXIDABLE	
45x20x1.2	0	147.100.516	147.100.564	1
45x20x1.2	2	147.102.513	147.102.561	
45x20x1.2	3	147.103.515	147.103.563	
45x20x1.2	4	147.104.510	147.104.565	

NOTA

LA POSICIÓN DE LAS BISAGRAS ESTÁ DEFINIDA DESDE EL INTERIOR DEL MUEBLE (LADO DE MECANIZACIÓN), A TENER EN CUENTA EN EL CASO DE QUE LA PUERTA SEA ASIMÉTRICA.

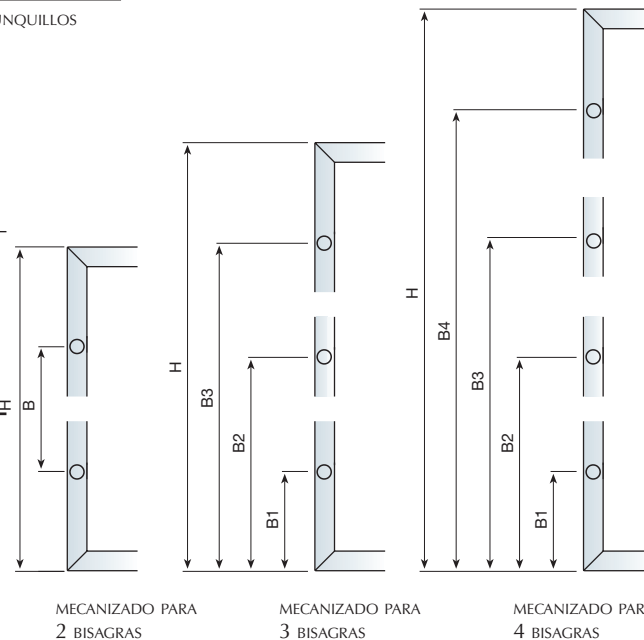
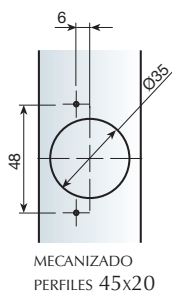

SEGÚN ESPECIFICACIÓN DE CLIENTE

VITRINA 45x20x1.2 SEGÚN ESPECIFICACIÓN DE CLIENTE

PERFIL	ANOD. PLATA MATE	ANOD. INOXIDABLE	
45x20x1.2	147.199.511	147.199.566	1

1 PERFIL PARA MECANIZAR

■ 45X20 1.2 VISIBLE

■ PERFIL PARA MECANIZAR

PERFIL PARA MECANIZAR 45x20x1.2 MM

	ANOD. PLATA MATE	ANOD. INOXIDABLE	
	149.460.511	149.460.566	10

BARRAS DE 6M. SE SUMINISTRA EN CAJAS DE 10UDS.

HERRAJES DE UNIÓN

		
ZINCADO	154.800.030	100

BOLSAS DE 4 ESCUADRA Y 8 TORNILLOS. SE SUMINISTRA EN CAJAS DE 100UDS. PARA 100 PUERTAS

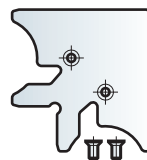
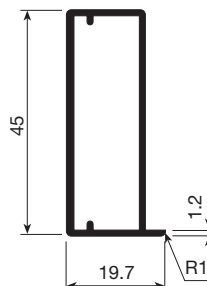

1 VITRINAS MECANIZADAS

45X20X20 VISIBLE

A MEDIDA

VITRINA 45x20x20 A MEDIDA

PERFIL	BISAGRAS	ANOD. PLATA MATE	
45x20x20	0	147.500.511	1
45x20x20	2	147.502.515	
45x20x20	3	147.503.510	
45x20x20	4	147.504.512	

NOTA

LA POSICIÓN DE LAS BISAGRAS ESTÁ DEFINIDA DESDE EL INTERIOR DEL MUEBLE (LADO DE MECANIZACIÓN), A TENER EN CUENTA EN EL CASO DE QUE LA PUERTA SEA ASIMÉTRICA.

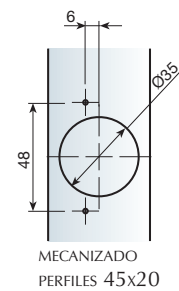
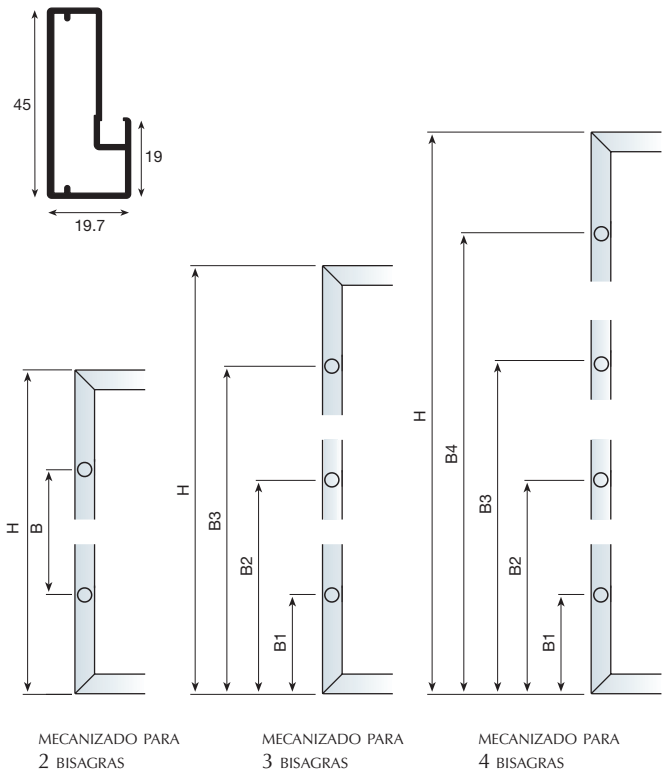

SEGÚN ESPECIFICACIÓN DE CLIENTE

VITRINA 45x20x20 SEGÚN ESPECIFICACIÓN DE CLIENTE

PERFIL	ANOD. PLATA MATE	
45x20x20	147.599.513	1

1 PERFIL PARA MECANIZAR

45X20X20 VISIBLE

■ PERFIL PARA MECANIZAR

PERFIL PARA MECANIZAR 45x20x20 MM

	ANOD. PLATA MATE	
	151.760.512	10

BARRAS DE 6M. SE SUMINISTRA EN CAJAS DE 10UDS.

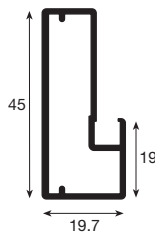

JUNQUILLO PARA CRISTAL DE 4MM.

	TRANSPARENTE	753.604.316	
			50

BARRAS DE 3M. SE SUMINISTRA EN CAJAS DE 50UDS. PARA CRISTAL DE 4MM.



HERRAJES DE UNIÓN

	ZINCADO	154.800.030	
			100

BOLSAS DE 4 ESCUADRA Y 8 TORNILLOS. SE SUMINISTRA EN CAJAS DE 100UDS. PARA 100 PUERTAS

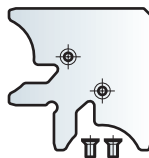

1 VITRINAS MECANIZADAS

50X20X7.5 VISIBLE

A MEDIDA

VITRINA 50x20x7.5 A MEDIDA

PERFIL	BISAGRAS	ANOD. PLATA MATE	
50x20x7.5	0	147.700.512	1
50x20x7.5	2	147.702.516	
50x20x7.5	3	147.703.511	
50x20x7.5	4	147.704.513	

NOTA

LA POSICIÓN DE LAS BISAGRAS ESTÁ DEFINIDA DESDE EL INTERIOR DEL MUEBLE (LADO DE MECANIZACIÓN), A TENER EN CUENTA EN EL CASO DE QUE LA PUERTA SEA ASIMÉTRICA.

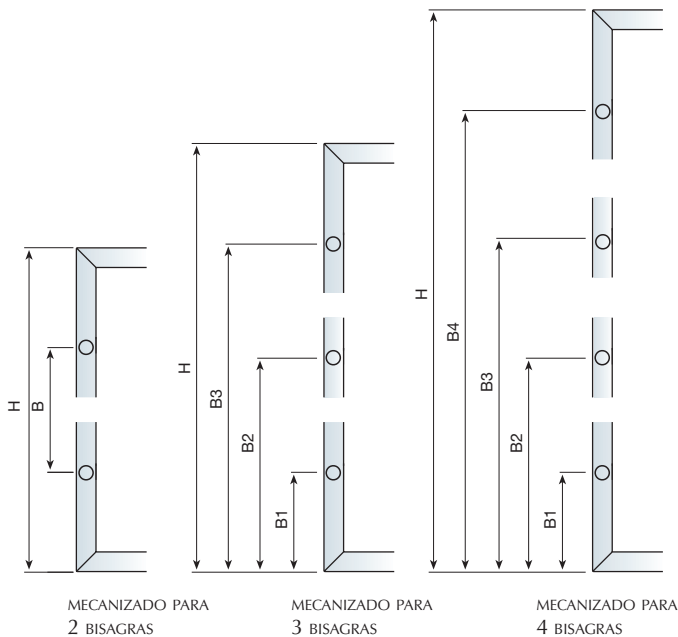
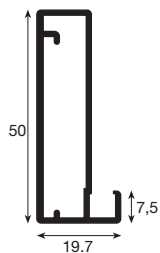
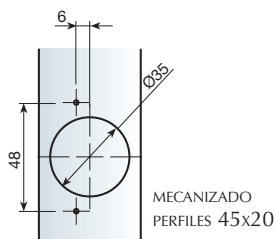

SEGÚN ESPECIFICACIÓN DE CLIENTE

VITRINA 45x20x20 SEGÚN ESPECIFICACIÓN DE CLIENTE

PERFIL	ANOD. PLATA MATE	
50x20x7.5	147.799.514	1

1 PERFIL PARA MECANIZAR

50X20X7.5 VISIBLE

■ PERFIL PARA MECANIZAR

PERFIL PARA MECANIZAR 50x20x7.5 MM

	ANOD. PLATA MATE	
	151.860.516	10

BARRAS DE 6M. SE SUMINISTRA EN CAJAS DE 10UDS.

JUNQUILLO PARA CRISTAL DE 4MM.

		
TRANSPARENTE	753.604.316	50

BARRAS DE 3M. SE SUMINISTRA EN CAJAS DE 50UDS. PARA CRISTAL DE 4MM.

HERRAJES DE UNIÓN

		
ZINCADO	154.800.030	100

BOLSAS DE 4 ESCUADRA Y 8 TORNILLOS. SE SUMINISTRA EN CAJAS DE 100UDS. PARA 100 PUERTAS.

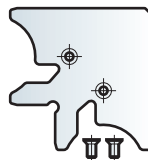
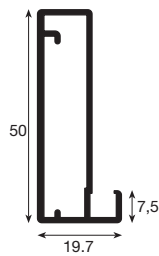

2 SIN MECANIZACIÓN: "SCREEN KIT"

PERFIL DE ALUMINIO

		
ANODIZADO PLATA MATE	150.630.513	20

BARRAS DE 3M. PARA CRISTAL DE 4MM.



PERFIL DE ALUMINIO

		
ANODIZADO PLATA MATE	150.930.500	20

BARRAS DE 3M. PARA CRISTAL DE 4MM.

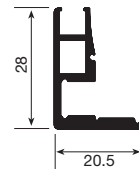

PERFIL REMATE DE PLÁSTICO

		
METALIZADO	150.730.311	20

BARRAS DE 3M.



JUNQUILLO PARA CRISTAL DE 4MM.

		
TRANSPARENTE	753.604.316	50

BARRAS DE 3M. PARA CRISTAL DE 4MM.



ESCUADRA DE UNIÓN DE PERFILES PARA MONTAJE SIN MECANIZACIÓN

ZINCADO	523.200.031	100
---------	-------------	-----

PARA 25 PUERTAS.

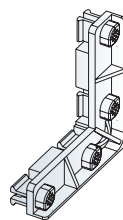

BISAGRA MESUCO 143 RAPID PARA MONTAJE SIN MECANIZACIÓN

APERTURA 110°		
RECTA	060.093.073	
ACODADA	061.193.075	50
SUPERACODADA	062.193.073	

PARA 25 PUERTAS.

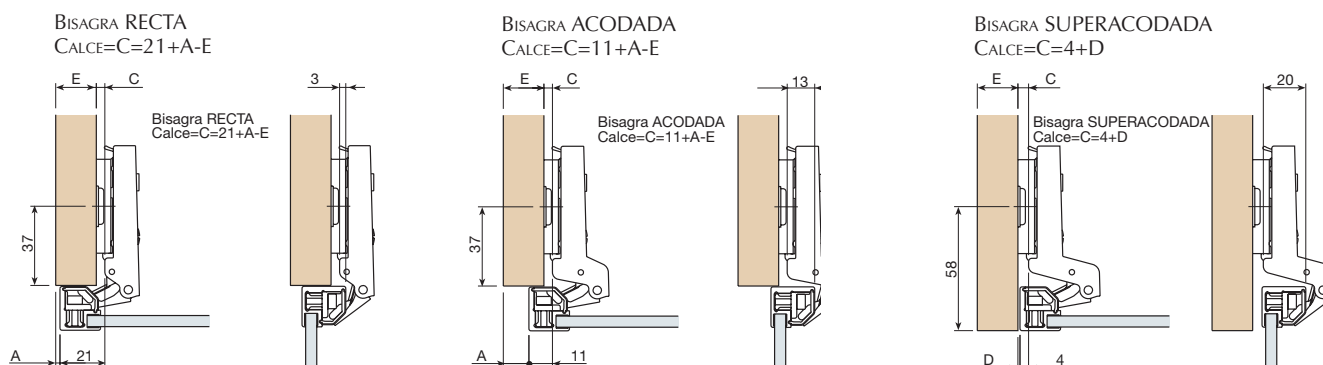
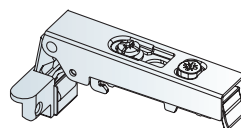

PLACA BASE SISTEMA 32 MONTAJE TIRAFONDOS

CALCE		
2	083.243.134	200
4	083.243.230	

SE SUMINISTRA EN BOLSAS DE 50UDS., EN CAJAS DE 200UDS. CADA BOLSA PARA 25 PUERTAS.



ADAPTADOR SISTEMA 32

APERTURA 110°		
ADAPTADOR SISTEMA 32 INDEPENDIENTE	526.200.032	
CON BASE PARA ELEVADOR DELTA	526.300.036	50
CON BASE PARA COMPÁS DE GAS	526.400.033	

PARA 25 PUERTAS.

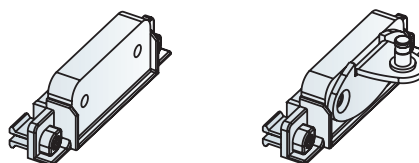

ADAPTADOR INDEPENDIENTE

ADAPTADOR ELEVADOR/COMPÁS

DATOS TÉCNICOS

Montaje

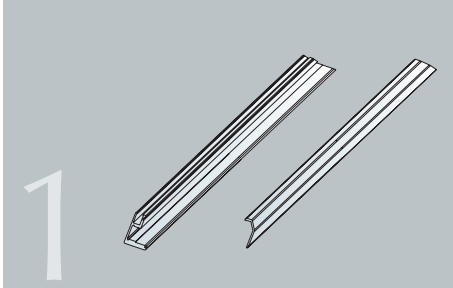

CORTAR LOS PERFILES DE ALUMINIO Y DE PLÁSTICO A LA MEDIDA DESEADA.

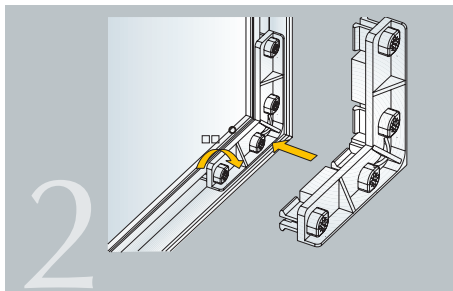

INTRODUCIR LOS JUNQUILLOS Y EL CRISTAL, MONTAR LA PUERTA CON LAS ESCUADRAS. PARA FIJAR LAS ESCUADRAS BASTA CON GIRAR 90° LOS TORNILLOS DE MONTAJE.

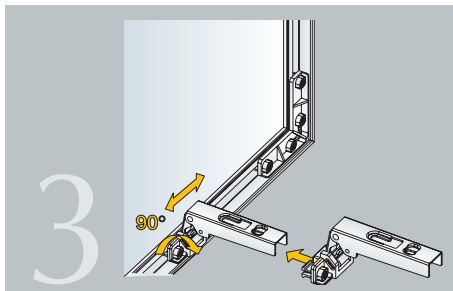

MONTAR LAS BISAGRAS. PRESIONAR LIGERAMENTE LA CAZOLETA CONTRA EL PERFIL, LA BISAGRA QUEDA MONTADA, NO SE SALE PERO PERMITE DESPLAZARSE A LO LARGO DEL PERFIL PARA SU POSICIONAMIENTO. PARA FIJAR LA POSICIÓN BASTA CON GIRAR 90° LOS TORNILLOS DE MONTAJE.

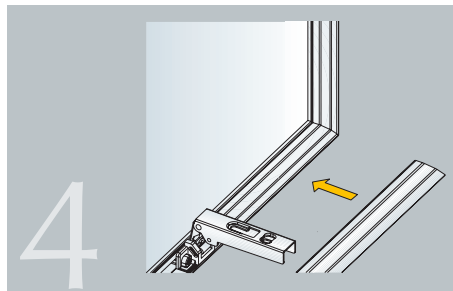

REMATAR LA PUERTA CON LOS PERFILES EMBELLECEDORES EN PLÁSTICO.