

Ventiladores centrífugos de alta presión en fundición de aluminio



CA



Construcción en aluminio de gran espesor para absorber ruidos y vibraciones

Ventiladores centrífugos de alta presión y simple aspiración con envolvente y turbina en fundición de aluminio.

Ventilador:

- Envolvente en fundición de aluminio
- Turbina en fundición de aluminio

Motor:

- Motores clase F, con rodamientos a bolas, protección IP55
- Trifásicos 230/400V.-50Hz.(hasta 5,5CV.) y 400/690V.-50Hz.(potencias superiores a 5,5CV.)
- Temperatura máxima del aire a transportar: -20°C.+ 120°C.

Acabado: Anticorrosivo en resina de poliéster, polimerizada a 190°C., previo desengrase alcalino y pretratamiento libre de fosfatos

Bajo demanda:

- Bobinados especiales para diferentes tensiones
- Ventilador preparado para transportar aire hasta 250°C
- Certificación ATEX Categoría 2

Características técnicas

Modelo	Velocidad (r/min)	Intensidad máxima admisible (A)			Potencia instalada (kW)	Caudal máximo (m3/h)	Nivel de presión sonora dB(A)	Peso Aprox. Kg.
		230V	400V	690V				
CA-234-2T	2870	1,73	1,00	-	0,37	280	72	10,2
CA-234-2M	2870	2,95	-	-	0,37	280	72	10,2
CA-142-2T-0,33	2735	1,39	0,80	-	0,25	460	73	22,5
CA-142-2T-0,50	2810	1,92	1,11	-	0,37	660	73	22,5
CA-148-2T-0,75	2830	2,42	1,40	-	0,55	420	74	28,0
CA-148-2T-1	2840	3,00	1,73	-	0,75	500	75	30,0
CA-148-2T-1,5	2850	4,16	2,40	-	1,10	990	76	32,0
CA-154-2T-1,5	2830	4,16	2,40	-	1,10	600	78	46,0
CA-154-2T-2	2860	5,63	3,25	-	1,50	800	79	48,5
CA-154-2T-3	2875	7,97	4,60	-	2,20	1280	80	50,5
CA-160-2T-2	2850	5,63	3,25	-	1,50	500	83	57,0
CA-160-2T-3	2860	7,97	4,60	-	2,20	900	84	58,0
CA-166-2T-3	2870	7,97	4,60	-	2,20	500	84	67,0
CA-166-2T-4	2870	10,57	6,10	-	3,00	950	85	73,0
CA-166-2T-5,5	2860	13,34	7,70	-	4,00	1600	86	76,0
CA-172-2T-5,5	2880	13,34	7,70	-	4,00	1100	87	90,0
CA-172-2T-7,5	2880	-	11,10	6,40	5,50	1710	88	112,0
CA-172-2T-10	2930	-	13,90	8,00	7,50	2300	89	124,0



Características acústicas

Los valores indicados, se determinan mediante medidas de nivel de presión y potencia sonora en dB(A) obtenidas en campo libre a una distancia equivalente a dos veces la envergadura del ventilador más el diámetro de la turbina, con un mínimo de 1,5 mts.

Espectro de potencia sonora Lw(A) en dB(A) por banda de frecuencia en Hz.

Modelo	63	125	250	500	1000	2000	4000	8000	Modelo	63	125	250	500	1000	2000	4000	8000
234	38	51	65	72	80	79	73	64	160-2	54	67	81	88	96	97	88	80
142	39	52	66	73	81	80	74	65	160-3	55	68	82	99	97	95	89	81
148-0,75	43	56	70	77	85	83	77	69	166-3	55	68	82	99	97	95	89	81
148-1	44	57	71	78	86	84	78	70	166-4	56	69	83	90	98	96	90	82
148-1,5	45	58	72	79	87	85	79	71	166-5,5	57	70	84	91	99	97	91	83
154-1,5	47	60	74	81	89	87	81	73	172-5,5	59	72	86	93	101	100	94	85
154-2	48	61	75	82	90	88	82	74	172-7,5	60	73	87	94	102	101	95	86
154-3	49	62	76	83	91	89	83	75	172-10	61	74	88	95	103	102	96	87

Orientaciones

Suministro standard LG 270

Posición LG 180 bajo demanda y con medidas de anclaje especiales.

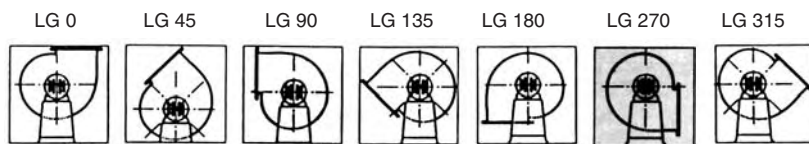

Dimensiones mm

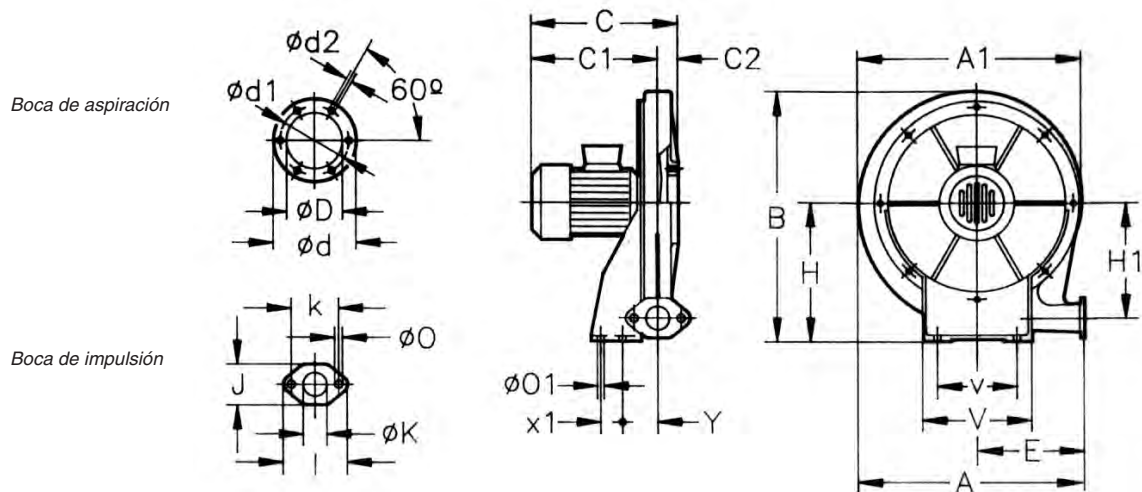

Modelo	A	A1	B	C	C1	C2	ØD	Ød	Ød1	Ød2	E	H	H1	I	J	ØK	k	ØO	ØO1	V	v	x1	Y
CA-234	376	381	415	272	242,5	29,5	98	130	115	M4	175	225	187	98	63	40	72	9	9	180	120	40	54



Dimensiones mm

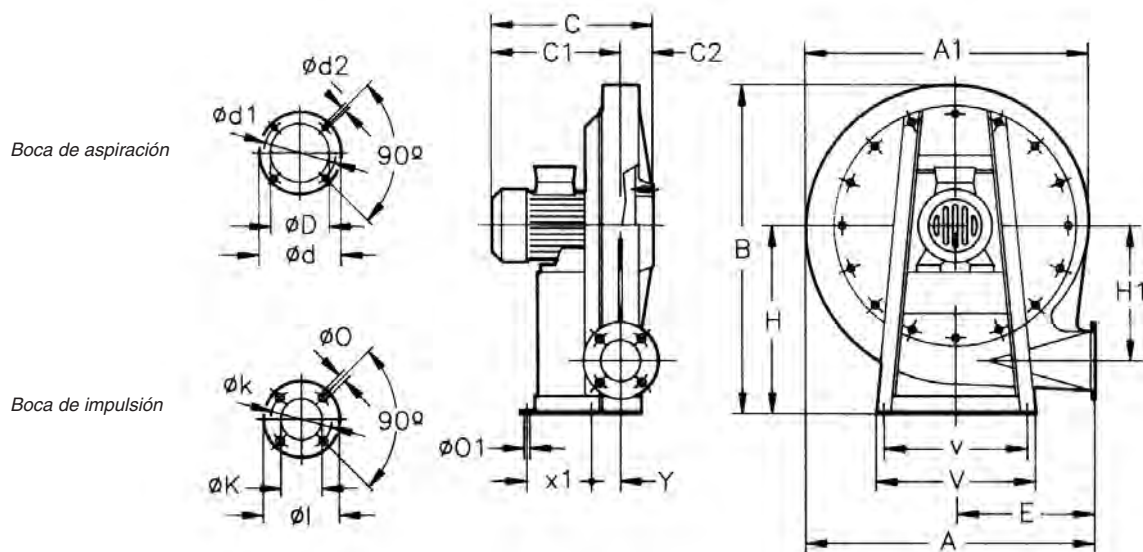

Modelo	A	A1	B	C	C1	C2	ØD	Ød	Ød1	Ød2	E	H	H1	ØI	ØK	Øk	ØO	O1	V	v	x1	Y
CA-142-2T-0,33	494	488	540	270	221,5	48,5	90	160	130	M8	240	301	235	120	60	90	11	12	300	270	130	51
CA-142-2T-0,50	494	488	540	290	241,5	48,5	90	160	130	M8	240	301	235	120	60	90	11	12	300	270	130	51
CA-148-2T-0,75	563	557,5	639	308,5	251,5	57	100	170	140	M8	270	360	269,5	150	73	110	11	12	330	290	140	60
CA-148-2T-1	563	557,5	639	324,5	267,5	57	100	170	140	M8	270	360	269,5	150	73	110	11	12	330	290	140	60
CA-148-2T-1,5	563	557,5	639	324,5	267,5	57	100	170	140	M8	270	360	269,5	150	73	110	11	12	330	290	140	60
CA-154-2T-1,5	630	625	708	348	268,5	79,5	115	183	155	M10	300	395	308	160	80	120	13	12	356	320	210	62
CA-154-2T-2	630	625	708	371	291,5	79,5	115	183	155	M10	300	395	308	160	80	120	13	12	356	320	210	62
CA-154-2T-3	630	625	708	396	316,5	79,5	115	183	155	M10	300	395	308	160	80	120	13	12	356	320	210	62
CA-160-2T-2	708	699	785	381	291	90	130	230	192	M10	336	440	338	160	85	120	13	12	373	322	220	62
CA-160-2T-3	708	699	785	406	316	90	130	230	192	M10	336	440	338	160	85	120	13	12	373	322	220	62
CA-166-2T-3	759	752	866	399	319,5	79,5	140	230	200	M10	364	490	372	160	85	120	13	12	450	400	245	70
CA-166-2T-4	759	752	866	423	343,5	79,5	140	230	200	M10	364	490	372	160	85	120	13	12	450	400	245	70
CA-166-2T-5,5	759	752	866	445	365,5	79,5	140	230	200	M10	364	490	372	160	85	120	13	12	450	400	265	70
CA-172-2T-5,5	818	813	923	451	371	80	148	230	200	M10	390	516	404	175	90	140	13	12	450	400	260	78
CA-172-2T-7,5	818	813	923	492	412	80	148	230	200	M10	390	516	404	175	90	140	13	12	450	400	300	78
CA-172-2T-10	818	813	923	492	412	80	148	230	200	M10	390	516	404	175	90	140	13	12	450	400	300	78

Accesorios

Ver apartado accesorios.

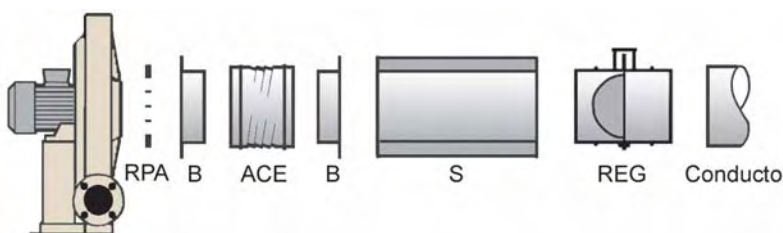



Curvas Características

Q = Caudal en m³/h y m³/s.

Pe = Presión estática en mm.c.a. y Pa.

