

Extractores helicoidales tubulares de gran robustez, con Certificación ATEX



HCT/ATEX



Banda de aluminio para prevenir chispas según norma EN-14986:2006



EEEx "e" marcado: $\text{CE} \text{Ex} \text{II 2 G. EEx e}$
 EEEx "d" marcado: $\text{CE} \text{Ex} \text{II 2 G. EEx d}$
 Organismo notificado: L.O.M.
 Nº de identificación: LOM3ATEX0157

Extractores helicoidales tubulares, con Certificación ATEX, para trabajar en atmósferas explosivas.

Ventilador:

- Envoltorio tubular en chapa de acero, con banda de aluminio en la zona de la hélice según norma EN-14986:2005
- Hélice fundición de aluminio
- Incorpora trampilla de inspección
- Dirección aire motor-hélice

Motor:

- Motores clase F, con rodamientos a bolas, protección IP55, con certificación ATEX, antiexplosivos EEEx"e" o antideflagrantes EEEx"d"
- Trifásicos 230/400V.-50Hz.(hasta 5,5CV.) y 400/690V.-50Hz.(potencias superiores a 5,5CV.)
- Temperatura de trabajo: -20°C.+ 40°C.

Acabado: Anticorrosivo en resina de poliéster, polimerizada a 190°C., previo desengrase alcalino y pretratamiento libre de fosfatos

Bajo demanda:

- Bobinados especiales para diferentes tensiones y frecuencias
- Construcción ATEX para diferentes categorías
- Extractores con motor de 2 velocidades

Características técnicas

Modelo	Velocidad	Potencia instalada (kW)	Caudal máximo (m3/h)	Nivel sonoro dB(A)	Peso aprox. con motor	
	(r/min)				EEEx-e (Kg)	EEEx-d (Kg)
HCT-35-2T/ATEX	2800	0,37	5750	77	13	23
HCT-35-4T/ATEX	1440	0,12	3100	59	12	19
HCT-40-2T-1,5/ATEX	2900	1,10	8750	84	27	40
HCT-40-4T-0,33/ATEX	1450	0,25	5100	64	21	30
HCT-45-2T-2/ATEX	2900	1,50	10300	86	30	49
HCT-45-2T-3/ATEX	2900	2,20	12800	88	33	54
HCT-45-4T-0,5/ATEX	1450	0,37	7100	68	25	33
HCT-50-4T-0,75/ATEX	1450	0,55	10300	70	27	41
HCT-56-4T-0,75/ATEX	1450	0,55	11000	72	32	46
HCT-56-4T-1/ATEX	1450	0,75	12900	73	34	47
HCT-56-4T-1,5/ATEX	1450	1,10	14000	74	36	55
HCT-56-4T-2/ATEX	1450	1,50	15300	75	39	59
HCT-56-6T-0,33/ATEX	950	0,25	8400	61	31	39
HCT-56-6T-0,5/ATEX	950	0,37	9300	61	34	43
HCT-56-6T-0,75/ATEX	950	0,55	10000	62	34	47
HCT-63-4T-1/ATEX	1450	0,75	14100	73	43	56
HCT-63-4T-1,5/ATEX	1450	1,10	17000	74	45	64
HCT-63-4T-2/ATEX	1450	1,50	18900	75	48	68
HCT-63-4T-3/ATEX	1450	2,20	22000	76	53	76
HCT-63-4T-4/ATEX	1450	3,00	25200	77	56	79
HCT-63-6T-0,5/ATEX	950	0,37	12000	64	43	52



Características técnicas

Modelo	Velocidad	Potencia instalada	Caudal máximo	Nivel sonoro	Peso aprox. con motor	
	(r/min)	(kW)	(m3/h)	dB(A)	EEx-e (Kg)	EEx-d (Kg)
HCT-63-6T-0,75/ATEX	950	0,55	12600	65	43	56
HCT-63-6T-1/ATEX	950	0,75	13800	66	45	64
HCT-71-4T-1,5/ATEX	1450	1,10	19900	78	51	70
HCT-71-4T-2/ATEX	1450	1,50	21000	79	54	74
HCT-71-4T-3/ATEX	1450	2,20	24000	81	60	83
HCT-71-4T-4/ATEX	1450	3,00	29400	82	63	86
HCT-71-6T-0,75/ATEX	950	0,55	15000	67	49	62
HCT-71-6T-1/ATEX	950	0,75	17200	68	51	70
HCT-71-6T-1,5/ATEX	950	1,10	21100	69	54	75
HCT-80-4T-3/ATEX	1450	2,20	29500	82	69	92
HCT-80-4T-4/ATEX	1450	3,00	37000	83	72	95
HCT-80-4T-5,5/ATEX	1450	4,00	40500	84	74	98
HCT-80-6T-1/ATEX	950	0,75	23000	71	60	79
HCT-80-6T-1,5/ATEX	950	1,10	26000	72	63	84
HCT-80-6T-2/ATEX	950	1,50	29700	73	71	95
HCT-80-6T-3/ATEX	950	2,20	33500	74	74	98
HCT-90-4T-4/ATEX	1450	3,00	40000	87	87	110
HCT-90-4T-5,5/ATEX	1450	4,00	46500	89	90	114
HCT-90-4T-7,5/ATEX	1450	5,50	51000	91	103	142
HCT-90-4T-10/ATEX	1450	7,50	54700	92	111	145
HCT-90-6T-2/ATEX	950	1,50	34300	77	86	110
HCT-90-6T-3/ATEX	950	2,20	38000	78	90	114
HCT-90-6T-4/ATEX	950	3,00	42400	79	102	142
HCT-100-4T-7,5/ATEX	1450	5,50	54000	92	98	137
HCT-100-4T-10/ATEX	1450	7,50	63000	93	122	156
HCT-100-4T-15/ATEX	1460	11,00	68000	94	159	256
HCT-100-4T-20/ATEX	1455	15,00	72000	95	178	279
HCT-100-6T-3/ATEX	950	2,20	43000	82	101	125
HCT-100-6T-4/ATEX	950	3,00	47000	83	113	153
HCT-100-6T-5,5/ATEX	950	4,00	53000	84	120	156

Dimensiones mm

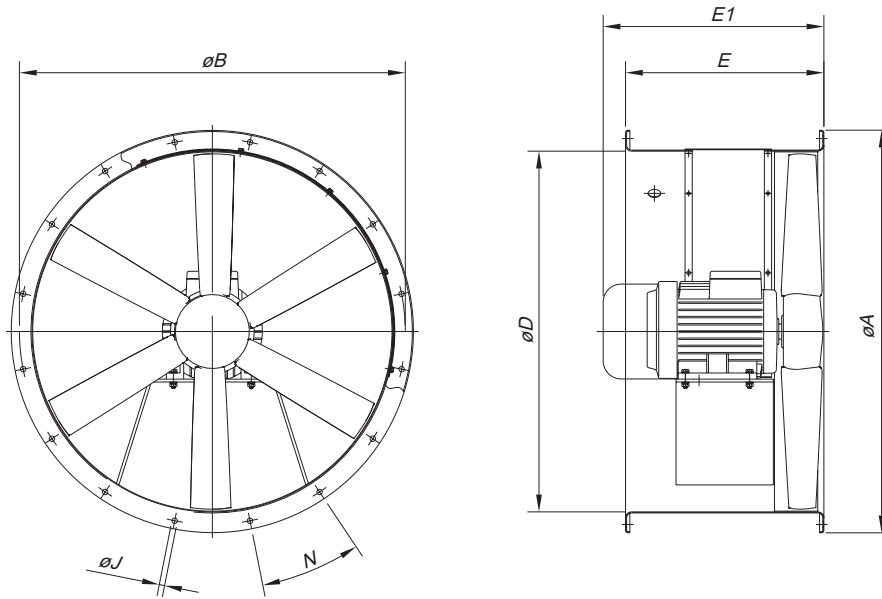

Modelo	ØA	ØB	D	EEx-"e"	EEx-"d"	øJ	N
HCT-35-2T/ATEX	425	395	355	230	230	10	8x45
HCT-35-4T/ATEX	425	395	355	230	230	10	8x45
HCT-40-2T-1.5/ATEX	490	450	410	320	351	12	8x45
HCT-40-4T-0.33/ATEX	490	450	410	320	320	12	8x45
HCT-45-2T-2/ATEX	540	500	460	360	379	12	8x45
HCT-45-2T-3/ATEX	540	500	460	360	379	12	8x45
HCT-45-4T-0.5/ATEX	540	500	460	360	370	12	8x45
HCT-50-4T-0.75/ATEX	600	560	514	360	366	12	12x30
HCT-56-4T-0.75/ATEX	660	620	560	400	400	12	12x30
HCT-56-4T-1/ATEX	660	620	560	400	400	12	12x30
HCT-56-4T-1.5/ATEX	660	620	560	400	420	12	12x30
HCT-56-4T-2/ATEX	660	620	560	400	420	12	12x30
HCT-56-6T-0.33/ATEX	660	620	560	400	400	12	12x30
HCT-56-6T-0.5/ATEX	660	620	560	400	400	12	12x30
HCT-56-6T-0.75/ATEX	660	620	560	400	400	12	12x30
HCT-63-4T-1/ATEX	730	690	640	430	430	12	12x30
HCT-63-4T-1.5/ATEX	730	690	640	430	430	12	12x30
HCT-63-4T-2/ATEX	730	690	640	430	430	12	12x30
HCT-63-4T-3/ATEX	730	690	640	430	490	12	12x30
HCT-63-4T-4/ATEX	730	690	640	430	490	12	12x30
HCT-63-6T-0.5/ATEX	730	690	640	430	430	12	12x30
HCT-63-6T-0.75/ATEX	730	690	640	430	430	12	12x30
HCT-63-6T-1/ATEX	730	690	640	430	430	12	12x30
HCT-71-4T-1.5/ATEX	810	770	710	500	500	12	16x2230'
HCT-71-4T-2/ATEX	810	770	710	500	500	12	16x2230'
HCT-71-4T-3/ATEX	810	770	710	500	517	12	16x2230'

Modelo	ØA	ØB	D	EEx-"e"	EEx-"d"	øJ	N
HCT-71-4T-4/ATEX	810	770	710	500	517	12	16x2230'
HCT-71-6T-0.75/ATEX	810	770	710	500	500	12	16x2230'
HCT-71-6T-1/ATEX	810	770	710	500	500	12	16x2230'
HCT-71-6T-1.5/ATEX	810	770	710	500	500	12	16x2230'
HCT-80-4T-3/ATEX	900	860	800	500	517	12	16x2230'
HCT-80-4T-4/ATEX	900	860	800	500	517	12	16x2230'
HCT-80-4T-5.5/ATEX	900	860	800	500	535	12	16x2230'
HCT-80-6T-1/ATEX	900	860	800	500	500	12	16x2230'
HCT-80-6T-1.5/ATEX	900	860	800	500	500	12	16x2230'
HCT-80-6T-2/ATEX	900	860	800	500	517	12	16x2230'
HCT-80-6T-3/ATEX	900	860	800	500	535	12	16x2230'
HCT-90-4T-4/ATEX	1015	970	900	500	517	15	16x2230'
HCT-90-4T-5.5/ATEX	1015	970	900	500	535	15	16x2230'
HCT-90-4T-7.5/ATEX	1015	970	900	500	571	15	16x2230'
HCT-90-4T-10/ATEX	1015	970	900	500	616	15	16x2230'
HCT-90-6T-2/ATEX	1015	970	900	500	517	15	16x2230'
HCT-90-6T-3/ATEX	1015	970	900	500	535	15	16x2230'
HCT-90-6T-4/ATEX	1015	970	900	500	571	15	16x2230'
HCT-100-4T-7.5/ATEX	1115	1070	1000	550	567	15	16x2230'
HCT-100-4T-10/ATEX	1115	1070	1000	550	612	15	16x2230'
HCT-100-4T-15/ATEX	1115	1070	1000	650	701	15	16x2230'
HCT-100-4T-20/ATEX	1115	1070	1000	650	701	15	16x2230'
HCT-100-6T-3/ATEX	1115	1070	1000	550	565	15	16x2230'
HCT-100-6T-4/ATEX	1115	1070	1000	550	567	15	16x2230'
HCT-100-6T-5.5/ATEX	1115	1070	1000	550	612	15	16x2230'



Características acústicas

Los valores indicados, se determinan mediante medidas de nivel de presión y potencia sonora en dB(A) obtenidas en campo libre a una distancia equivalente a dos veces la envergadura del ventilador más el diámetro de la hélice, con un mínimo de 1,5 mts.

Espectro de potencia sonora Lw(A) en dB(A) por banda de frecuencia en Hz.

Modelo	Lp dB(A)	63	125	250	500	1000	2000	4000	8000	Modelo	Lp dB(A)	63	125	250	500	1000	2000	4000	8000
HCT-35-2T/ATEX	77	48	63	82	81	82	81	76	67	HCT-71-4T-4/ATEX	82	59	79	87	92	94	91	84	73
HCT-35-4T/ATEX	59	30	45	64	63	64	63	58	49	HCT-71-6T-0,75/ATEX	67	44	64	72	77	79	76	69	58
HCT-40-2T-1,5/ATEX	84	49	66	78	86	91	91	87	80	HCT-71-6T-1/ATEX	68	45	65	73	78	80	77	70	59
HCT-40-4T-0,33/ATEX	64	29	46	58	66	71	71	67	60	HCT-71-6T-1,5/ATEX	69	46	66	74	79	81	78	71	60
HCT-45-2T-2/ATEX	86	51	68	80	88	93	93	89	82	HCT-80-4T-3/ATEX	82	59	79	87	92	94	91	84	73
HCT-45-2T-3/ATEX	88	53	70	82	90	95	95	91	84	HCT-80-4T-4/ATEX	83	60	80	88	93	95	92	85	74
HCT-45-4T-0,5/ATEX	68	33	50	62	70	75	75	71	64	HCT-80-4T-5,5/ATEX	84	61	81	89	94	96	93	86	75
HCT-50-4T-0,75/ATEX	70	37	54	67	74	79	80	75	68	HCT-80-6T-1/ATEX	71	48	68	76	81	83	80	73	62
HCT-56-4T-0,75/ATEX	72	47	67	75	80	82	79	72	61	HCT-80-6T-1,5/ATEX	72	49	69	77	82	84	81	74	63
HCT-56-4T-1/ATEX	73	48	68	76	81	83	80	73	62	HCT-80-6T-2/ATEX	73	50	70	78	83	85	82	75	64
HCT-56-4T-1,5/ATEX	74	49	69	77	82	84	81	74	63	HCT-80-6T-3/ATEX	74	51	71	79	84	86	83	76	65
HCT-56-4T-2/ATEX	75	50	70	78	83	85	82	75	64	HCT-90-4T-4/ATEX	87	65	86	93	98	101	97	90	79
HCT-56-6T-0,33/ATEX	61	36	56	64	69	71	68	61	50	HCT-90-4T-5,5/ATEX	89	67	88	95	100	103	99	92	81
HCT-56-6T-0,5/ATEX	61	36	56	64	69	71	68	61	50	HCT-90-4T-7,5/ATEX	91	69	90	97	102	105	101	94	83
HCT-56-6T-0,75/ATEX	62	37	57	65	70	72	69	62	51	HCT-90-4T-10/ATEX	92	70	91	98	103	106	102	95	84
HCT-63-4T-1/ATEX	73	50	70	78	83	85	82	75	64	HCT-90-6T-2/ATEX	77	55	76	83	88	91	87	80	69
HCT-63-4T-1,5/ATEX	74	51	71	79	84	86	83	76	65	HCT-90-6T-3/ATEX	78	56	77	84	89	92	88	81	70
HCT-63-4T-2/ATEX	75	52	72	80	85	87	84	77	66	HCT-90-6T-4/ATEX	79	57	78	85	90	93	89	82	71
HCT-63-4T-3/ATEX	76	53	73	81	86	88	85	78	67	HCT-100-4T-7,5/ATEX	92	72	92	100	105	107	104	97	86
HCT-63-4T-4/ATEX	77	54	74	82	87	89	86	79	68	HCT-100-4T-10/ATEX	93	73	93	101	106	108	105	98	87
HCT-63-6T-0,5/ATEX	64	41	61	69	74	76	73	66	55	HCT-100-4T-15/ATEX	94	74	94	102	107	109	106	99	88
HCT-63-6T-0,75/ATEX	65	42	62	70	75	77	74	67	56	HCT-100-4T-20/ATEX	95	75	95	103	108	110	107	100	89
HCT-63-6T-1/ATEX	66	43	63	71	76	78	75	68	57	HCT-100-6T-3/ATEX	82	62	82	90	95	97	94	87	76
HCT-71-4T-1,5/ATEX	78	55	75	83	88	90	87	80	69	HCT-100-6T-4/ATEX	83	63	83	91	96	98	95	88	77
HCT-71-4T-2/ATEX	79	56	76	84	89	91	88	81	70	HCT-100-6T-5,5/ATEX	84	64	84	92	97	99	96	89	78
HCT-71-4T-3/ATEX	81	58	78	86	91	93	90	83	72										

Curvas Características

Ver curvas características serie HCT.

Accesorios

Ver apartado accesorios.

