

Ejes rectos con freno "Monobloc" STANDARD. (velocidad 25/40 Km/h).

STANDARD straight axles with "Monobloc" brake. (speed 25/40 Km/h).

AGRÍCOLA

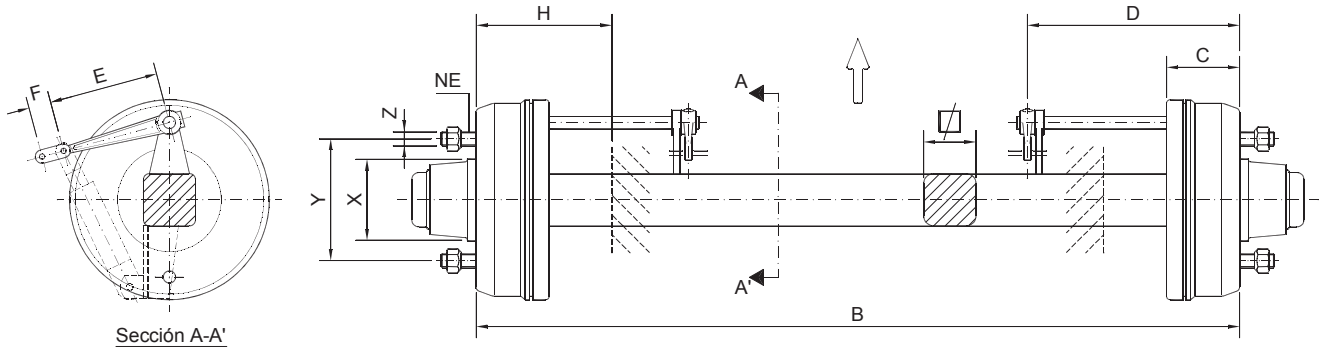

Cód. Code	Referencia/Reference	Ataque Wheel fixing X x Y/NE-Z	Rodamientos Bearings	Cotas (mm) Dimensions (mm)						M.M.T.A. por semi-eje (Kg.) a 40 Km/h M.M.T.A. per semi-axle (Kg.) at 40Km/h			Peso Aprox. Aprox. weight (Kg.)	
				D	C	E	F	H	B					
EQUIPO DE FRENO 140Ax30 / 140Ax30 BRAKE EQUIPMENT														
13059	RM- 3025.140x030.05812-850	30	58 x 98 / 4-M12 Asiento esférico R12	30204/30205	243	61	100	-	135	850	850	700	600	14,3
12038	RM- 3025.140x030.05812-1000								1000	15,2				
312039	RM- 3525.140x030.05812-1100								205	1100				18,2
EQUIPO DE FRENO 200Ax40 / 200Ax40 BRAKE EQUIPMENT														
13060	RM- 4030.200x040.09316-1200	40		30205/30206	395				205	1200	1500	1300	1050	31,6
12041	RM- 4030.200x040.09316-1250									1250				32,2
13237	RM- 4540.200x040.09316-1300	45		30206/30208						1300	2200	1900	1500	48,6
13180	RM- 5045.200x040.09316-1100	50	93 x 140 / 5-M16 Asiento esférico R14	30206/30209	415	66	110	30	250	1100	2700	2200	2000	39
14297	RM- 5045.200x040.09316-1200									1200				40,9
12042	RM- 5045.200x040.09316-1350									1350				43,6
13150	RM- 5045.200x040.09316-1450									1450				45,6
13267	RM- 5045.200x040.09316-1500									1500				46,6
14352	RM- 5045.200x040.09316-1700									1700				50,6
14298	RM- 5045.200x040.09316-1800	1800	52,6											
EQUIPO DE FRENO 250Ax40 / 250Ax40 BRAKE EQUIPMENT														
13182	RM- 5045.250x040.016018-1200	50		30206/30209					250	1200	2700	2200	2000	43
12357	RM- 6050.250x040.016018-1300									1300	68,5			
13439	RM- 6050.250x040.016018-1450	60	160 x 205 / 6-M18 Asiento esférico R16	30207/30210	400	72	110	30	250	1450	3800	3400	3000	72,5
11207	RM- 6050.250x040.016018-1700									1700	77			

NOTAS DE INTERÉS: / NOTES OF INTEREST:

- * M.M.T.A.: Masa Máxima Técnicamente Admisible. / Technically Allowable Maximum Mass.
- * Capacidad de carga a velocidad inferior 40Km/h.: Consultar pag 61. / Load capacity at a speed of less than 40 Km/h.: Consult page 61.
- * M.M.T.A. indicado se garantiza con la cota "H" que refleja el catálogo. / The M.M.T.A. indicated is guaranteed with the "H" cote of this catalogue.
- * NE: Número de tornillos (espárragos). / NE: Number of screws. (studs).

Ejes rectos con freno "Monobloc" STANDARD (velocidad 25/40 Km.)

STANDARD straight axles with "Monobloc" brake. (speed 25/40 Km.h)

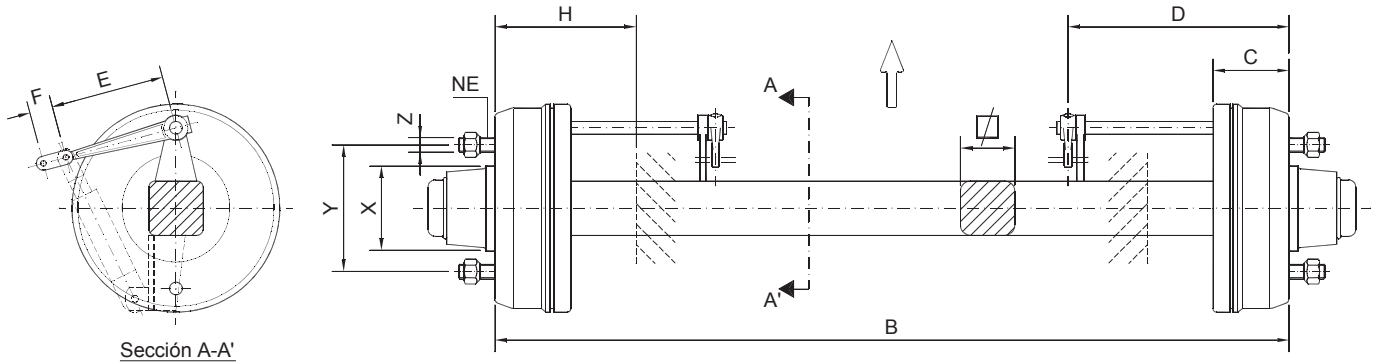

Cód. Code	Referencia/Reference	Ataque Wheel fixing X x Y/NE-Z	Rodamientos Bearings	Cotas (mm) Dimensions (mm)						M.M.T.A. por semi-eje (Kg.) a 40 Km/h M.M.T.A. per semi-axle (Kg.) at 40Km/h			Peso Aprox. Aprox. weight (Kg.)		
				D	C	E	F	H	B						
EQUIPO DE FRENO 300Ax60 / 300Ax60 BRAKE EQUIPMENT															
13657	RM- 6055.300x060.16018-1350	60	30208/30211	160 x 205 / 6 - M18 Asiento esférico R16	425					250	1350	4400	3800	3400	90,7
12053	RM- 6055.300x060.16018-1500										1500				95
13070	RM- 6055.300x060.16018-1600										1600				98
13071	RM- 6055.300x060.16018-1700										1700	100,8			
13123	RM- 7055.300x060.16018-1350										70	30210/30213	160 x 205 / 6 - M20 Asiento esférico R18	430	94
12055	RM- 7055.300x060.16018-1500	1500	111,5												
12002	RM- 7065.300x060.16018-1500	1600	113,6												
13075	RM- 7065.300x060.16018-1600	1700	117,6												
13418	RM- 7065.300x060.16018-1700	1900	121,4												
2999	RM- 7065.300x060.16018-1900	80	30211/30215	160 x 205 / 6 - M20 Asiento esférico R18	430	94	150	30	350	6000	5300	4500	129		
13076	RM- 7065.300x060.16020-1600									1600			120,8		
13977	RM- 8065.300x060.16018-1600									1700			138		
13078	RM- 8065.300x060.16020-1600									1600	139				
13079	RM- 8065.300x060.16020-1700									1700	144				
13082	RM- 8075.300x060.16020-1600	90	30211/30215	160 x 205 / 6 - M20 Asiento esférico R18	430	94	150	30	400	6000	6350	5500	143		
13083	RM- 8075.300x060.16020-1700									7100			148		
13084	RM- 8075.300x060.16020-1800									1800			152		
12081	RM- 9075.300x060.16020-1600									1600	161				
13085	RM- 9075.300x060.16020-1700									1700	167				
13086	RM- 9075.300x060.16020-1800	1800	173												
13087	RM- 9075.300x060.16020-1900	1900	179												

NOTAS DE INTERÉS: / NOTES OF INTEREST:

- * M.M.T.A.: Masa Máxima Técnicamente Admisible. / Technically Allowable Maximum Mass.
- * Capacidad de carga a velocidad inferior 40Km/h.: Consultar pag 61. / Load capacity at a speed of less than 40 Km/h.: Consult page 61.
- * M.M.T.A. Indicado se garantiza con la cota "H" que refleja el catálogo. / The M.M.T.A. indicated is guaranteed with the "H" cote of this catalogue.
- * NE: Número de tornillos (espárragos). / NE: Number of screws. (studs).