

Palancas de freno.

Brake levers.

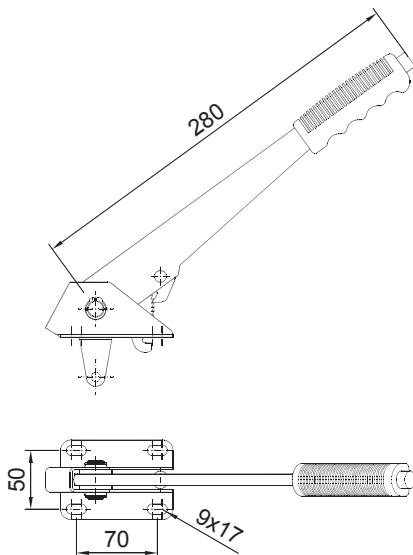

PALANCA DE FRENO CON PULSADOR / BRAKE LEVER WITH PRESS BUTTON.

Cód. Code	Referencia/Reference	Ref de origen Original. Ref.	Long. de la palanca (mm.)	Peso Aprox. Aprox. weight (Kg.)
16935	PLC. FR. C/SPT. DE TIRO FIJO /280 / BRAKE LEVER WITH FIXED DRAW SUPPORT	1012201	280	0,6

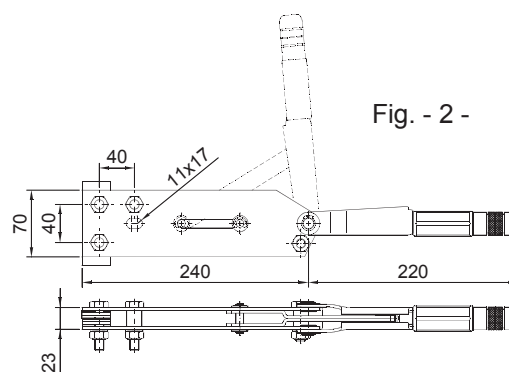
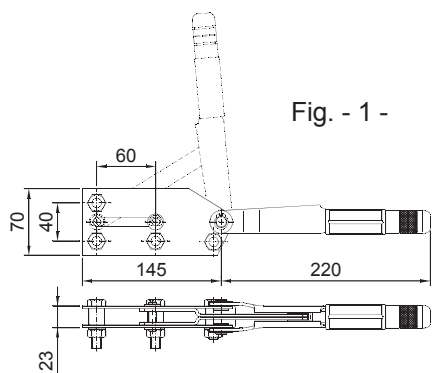

PALANCA DE FRENO CON REGULADOR DE TIRO / BRAKE LEVERS.

Cód. Code	Referencia/Reference	Ref de origen Original. Ref.	Fig.	Long. det. cuerpo (mm.)	Long. de la palanca (mm.)	Peso Aprox. Aprox. weight (Kg.)
5941	PLC. FR. REG PUÑO METAL /145 + 220	1526500	1	145	220	1,2
5942	PLC. FR. REG PUÑO METAL /240 + 220	1526003	2	240		1,8

PALANCA DE FRENO / BRAKE LEVER.

Cód. Code	Referencia/Reference	Peso Aprox. Aprox. weight (Kg.)
1408	PALANCA DE FRENO P-162C/MANETA / WITH HANDLE	2,4

* Palanca de freno normalizada según norma CUNA 441-02. / Standardised brake lever to CUNA 441-02 standards.

