



**C 400 H**  
**C 500 H**  
**C 600 H**



[www.ausea.com](http://www.ausea.com)

**AUSA - Automóviles Utilitarios, S.L.U.** ● Ctra. de Vic, Km 2.8 - P.O.B. 194, 08243 Manresa - BARCELONA (ESPAÑA) Tel.: +34 93 874 73 11 E-mail: [ausea@ausea.com](mailto:ausea@ausea.com)

ISO 9001

ISO 14001



(Sede central AUSA-Manresa)

**AUSA MADRID** ● Pol. Ind. Coslada-Marconi 15-17, 28820 Coslada - MADRID (ESPAÑA) Tel.: +34 91 669 00 06 E-mail: [ausea.madrid@ausea.com](mailto:ausea.madrid@ausea.com)  
**AUSA FRANCE** ● Z. I. Saint Charles-Rue de Zürich, 66000 PERPIGNAN (FRANCE) Tel.: +33 (0) 4 68 54 38 97 E-mail: [ausea.france@ausea.com](mailto:ausea.france@ausea.com)  
**AUSA UK** ● UNITS 6 & 7 Alma Industrial Estate, Regent Street - ROCHDALE OL12 0HQ (U.K.) Tel.: +44 (0) 1706 64 96 91 E-mail: [ausea.uk@ausea.com](mailto:ausea.uk@ausea.com)  
**AUSA DEUTSCHLAND GmbH.** ● Heinrich - Welken Straße 5, 59069 HAMM - RHYNERN (GERMANY) Tel.: +49 2385922245 E-mail: [ausea.deutschland@ausea.com](mailto:ausea.deutschland@ausea.com)  
**AUSA CORPORATION** ● 2655 Le Jeune Road - Suite 916, CORAL GABLES FL 33134 (USA) Toll free: 1 800 820 AUSA E-mail: [ausea.corp@ausea.com](mailto:ausea.corp@ausea.com)  
**BEIJING REPRESENTATIVE OFFICE** ● Address Room 527, HengXiang Building, Tuanjiehu Nanli, Chaoyang District. - Beijing 100026 CHINA  
 Tel: 86-10-8597 1983 - Fax: 86-10-8597 1993 - E-mail: [lunafeng@ausea.com](mailto:lunafeng@ausea.com)



C 400 H\_4000 Kg

C 500 H\_5000 Kg

C 600 H\_6000 Kg



## MEASUREMENTS (mm)

		C 400 H	C 500 H	C 600 H
Lift	<b>h3</b> Lift	3600		
	<b>h2</b> Normal free lift	100		60
Fork support		FEM 3B	FEM 4B	FEM 4B
Fork size (standard)	L x B x D	1200X140X50	1200x130x60	1200x150x60
Mast tilt angle	Forward / rear	14°/12°		15°/12°
Overall	<b>L</b> Total length incl. fork support	3685		3780
	<b>B</b> Overall width	2000		2185
Measurements	<b>h1</b> Height, operational mast retracted	2800		2775
	<b>h4</b> Height, operational mast extended	4450		4580
	<b>h6</b> Height above safety roof	2670		2690
Track	Centre tyres front/rear	1590/1570		1740/1510
	Load distance x from center front axle	740		880
Working corridor width		5475		5825
	Pallet 800 x 1200 lengthwise			

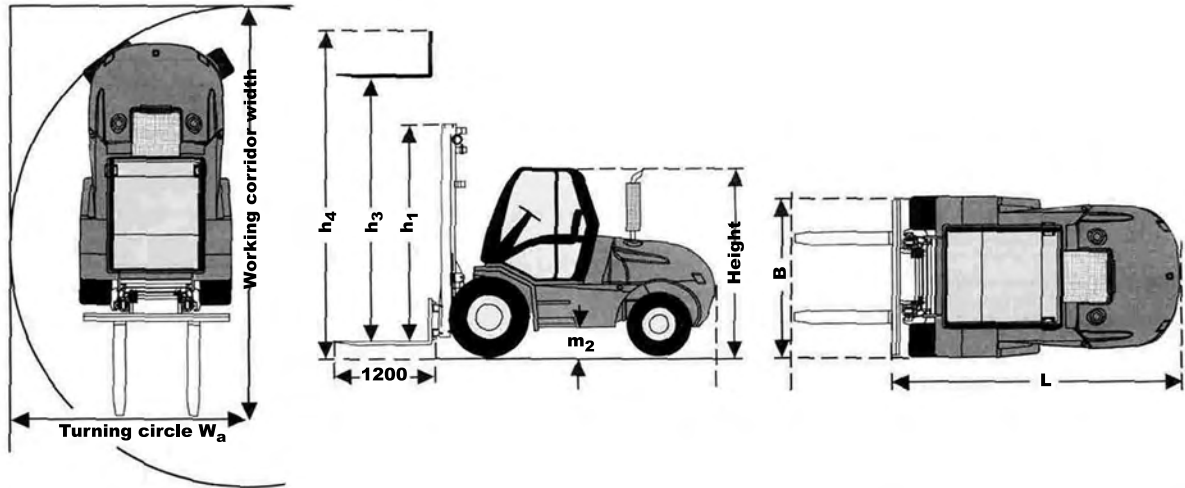

## TECHNICAL SPECIFICATIONS

		C 400 H	C 400 H x4	C 500 H	C 500 H x4	C 600 H	C 600 H x4
Load capacity (Kg)	Lifting load without support	4000		5000		6000	
At loadcenter	Center of gravity (mm)			600			
Lifting height	h3 (Standard duplex mast) (mm)			3600			
Combustion engine	Drive unit			Diesel			
	Battery (voltage/size) (V/Ah)			12/110			
	Manufacturer/Model	PERKINS 1004.42	DEUTZ BF4M2012	PERKINS 1004.42	DEUTZ BF4M2012	PERKINS 1004-40T	DEUTZ BF4M2012
	Power acc./DIN 70020 (KW/HP)	63/86	74.9/102.2	63/86	74.9/102.2	74.5/101	74.9/102.2
Number of revolutions (rpm)		2300	2500	2300	2500	2200	2500
	Cylinders/cubic capacity			4/4000			
Steering type	Seat-steering			Hydraulic			
Gearbox	Type/steps			Hydrostatic, 2 automatic			
Gearshift	Type/steps			Load-dependent, automatic			
Unladen weight (Kg)		8350	8500	8850	9000	10170	
Axle weight (Kg)	Without load front / rear	3950/4400	3950/4550	4050/4800	4050/4950	4710/5460	
Gradient negotiable	With full load / without load	30/35	32/40	28/35	32/40	28/35	
Speeds	Driving with/without lifting load (Km/h)			20/20		17/20	
	Lifting with/without load (m/s)			0.43/0.50		0.23/0.36	
	Lowering with/without load (m/s)			0.48/0.38		0.42/0.40	
Tyres	Front	16/70 x 20	405/70-20	16/70 x 20	405/70-20	18-19.5 16 PR	
	Rear	11.5/80 x 15.3 *	12-16.5	11.5/80 x 15.3 *	12-16.5	265/70 R 19.5 **	
Ground Clearance	m <sub>1</sub> At deepest point (mm)			260		280-310	
	m <sub>2</sub> Half Wheelbase (mm)			380		400	
External turning circle	W <sub>a</sub> (mm)	3300	4250	3300	4250	3650	
Service brake				Hydraulic, power assisted			
Parking brake				Hydraulic			
Working pressure (bar)				180			
Sound level	Average at driver's ear (dB)(A)			78		79	

\* Optional 8.25-15 \*\* Optional 305/70 R 19.5

## STANDARD EQUIPMENT

Comfort full cab, tilting hydraulically with heater and GRAMMER comfort seat;
Green tinted glass; 2 windscreen wipers; 1 panorama rear view mirror; Three valves joystick control;
2 lockable doors; Noise reduction kit; Beacon; 3 worklights;
Electro-Hydraulic parking brake and differential lock;
Exhaust and cyclon preairfilter mounted upwards;
Full road Lighting equipment in accordance with CE regulations for traffic lighting equipment;
Overhead exhaust muffler;

## OPTIONAL EQUIPMENT

Sideshift FEM III 1.850 mm	Sideshift FEM IV 2.000 mm
2 hydraulic kits; 4th valve; BLAUPUNKT Stereo radio cassette player; Sawmill Kit	