

Technical leaflet

Float Switch Type AKS 38

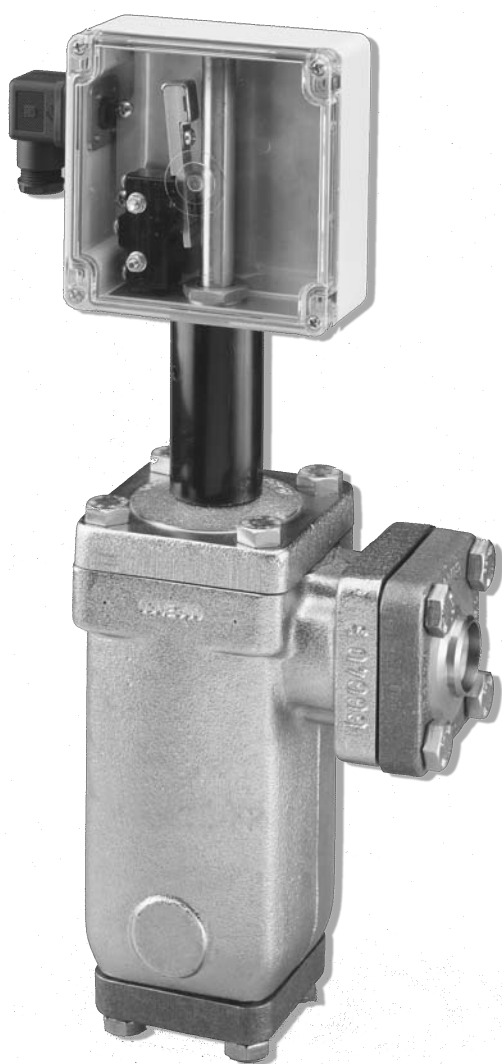

Introduction

AKS 38 is an electro-mechanical float switch designed to provide a reliable, electro-mechanical response to liquid level changes.

The simple and basic design ensures long lifetime performance and reliable operation for many applications.

AKS 38 can control liquid level in vessels and accumulators or can be used as a low/high level safety alarm.

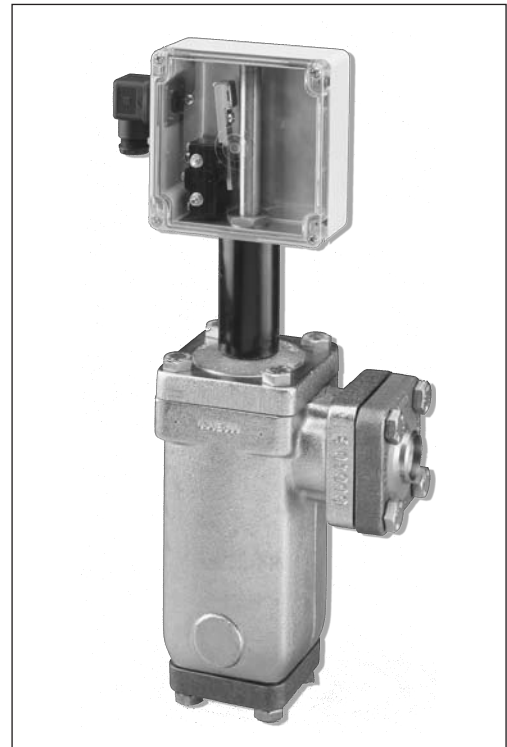
Features

- Based on Danfoss float type 38E
- DIN, ANSI and FPT/NPT flanges
- The switch box can be placed in any position on top of float housing for ease of installation.
- Adjustable liquid level differential switch point.
- Electric magnetic microswitch, mechanically activated.
- The complete switch box can easily be replaced without any interference with the refrigeration system.
- Switch box supplied with a DIN plug for easy installation and service.
- Flanges included.

Technical data

- **Refrigerants**
Can be used for all common non-flammable refrigerants, including R717 and non-corrosive gases/liquids dependent on sealing material compatibility. Flammable hydrocarbons are not recommended.
- **Temperature range**
-50°C/+65°C (-58°F/+149°F)
- **Pressure range**
AKS 38 is designed for a max. working pressure of 28 bar g (406 psi g)
- **Material**
Float housing:
Cast Iron, zinc chromated, EN-GJS-400-18-LT
Floats housing bolts:
Stainless steel
A2-70 (DIN 267-11) / ASTM A-276
Flanges:
P285QH
EN 10222-4 / AISI 3004, A276
Flange gasket:
Fiber, non asbestos
Pressure tube:
Stainless steel
X5CrNi18-10, EN 10088 / AISI 304, A276
O-ring:
Neoprene (Cloroprene)
Gasket between pressure tube and housing:
Aluminium
Electrical switch box:
Shock resistant polycarbonate
CT-661-T

IMPORTANT

Should pressure testing in excess of 28 bar g (406 psig) be necessary then the internal float assembly must be removed, thus allowing a maximum test pressure of 42 bar g (609 psig).

Technical data

- *Electrical data*
 - **Change over Micro (SPDT) switch**
250 V a.c / 10 A
30 V d.c / 5 A
Normally Open (NO) and Normally Closed (NC) function
 - **DIN Plug**
DIN 43650 connection
PG 11, 8-10 mm (0.31"-0.39")
Screw terminal 1.5 mm² (16 AWG)
3+PE
- *Liquid level differential*
Variable between 12.5 mm to 50 mm (½" to 2") in 12.5 mm (½") increments. Required differential setting should be made prior to installation. Factory set at 50 mm (2").
- *Enclosure*
IP 65
- *Weight (including flanges)*
9.75 kg (21.5 lb)
- *Approvals*
CE – for further details please see instruction.

Design

AKS 38 is an electro-mechanical float switch.

The design is based on a mechanical float, which will operate in the refrigerant. When the set level is reached an electrical volt free micro (SPDT) switch will be activated.

The microswitch is located in the switch box which has a clear front cover and allows viewing of the switch position. The micro-switch is fully isolated from the refrigeration system and operates by means of a magnet.

AKS 38 is supplied with a DIN plug for the electrical connections. The microswitch

provides volt free contacts to open/close solenoid valves or energise/de-energise contactors for the starting/stopping refrigerant pumps/compressors.

Can be used as a safety device for acoustic alarms/switches for visual indication when there is a danger of high or low liquid level.

The switch box can be placed in any position on top of the float housing for easy installation and can be replaced without any interference with the refrigeration system. Flanges are included.

Function

- 1 Internal float assembly
- 2 Switch box
- 3 M4x8 pinol tailstock screw
- 4 Top cover
- 5 4 pcs M12x35 stainless steel bolts
- 6 AKS 38 housing
- 7 Pressure tube
- 8 Top cover gasket
- 9 O-ring for pressure tube
- 10 DIN-plug for electrical connection
- 11 Aluminium gasket
- 12 Locking ring for internal float
- 13 Stainless steel bolts
- 14 Flanges
- 15 Flange gaskets

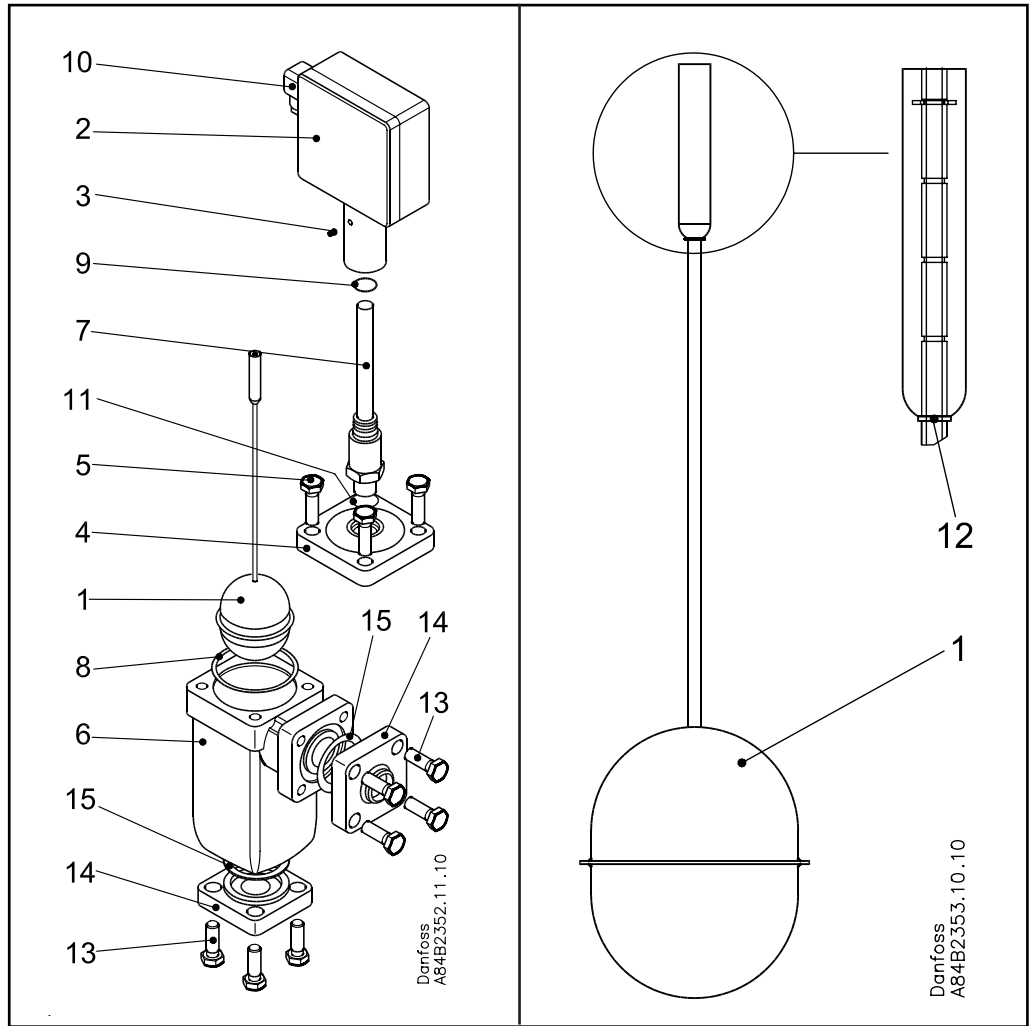

AKS 38 incorporates an internal float assembly (1), which will operate directly in accordance with the refrigerant level.

The internal float will follow the liquid level vertically up and down.

The upper part of the internal float assembly moves within the pressure tube (7).

At a specific switch point the upper part of the internal float assembly will via a magnet activate the electrical microswitch in the switch box (2).

A volt free signal can be detected by wiring to terminals at the DIN-plug (10). The actual switch point can be adjusted by means of a locking ring (12) before installation.

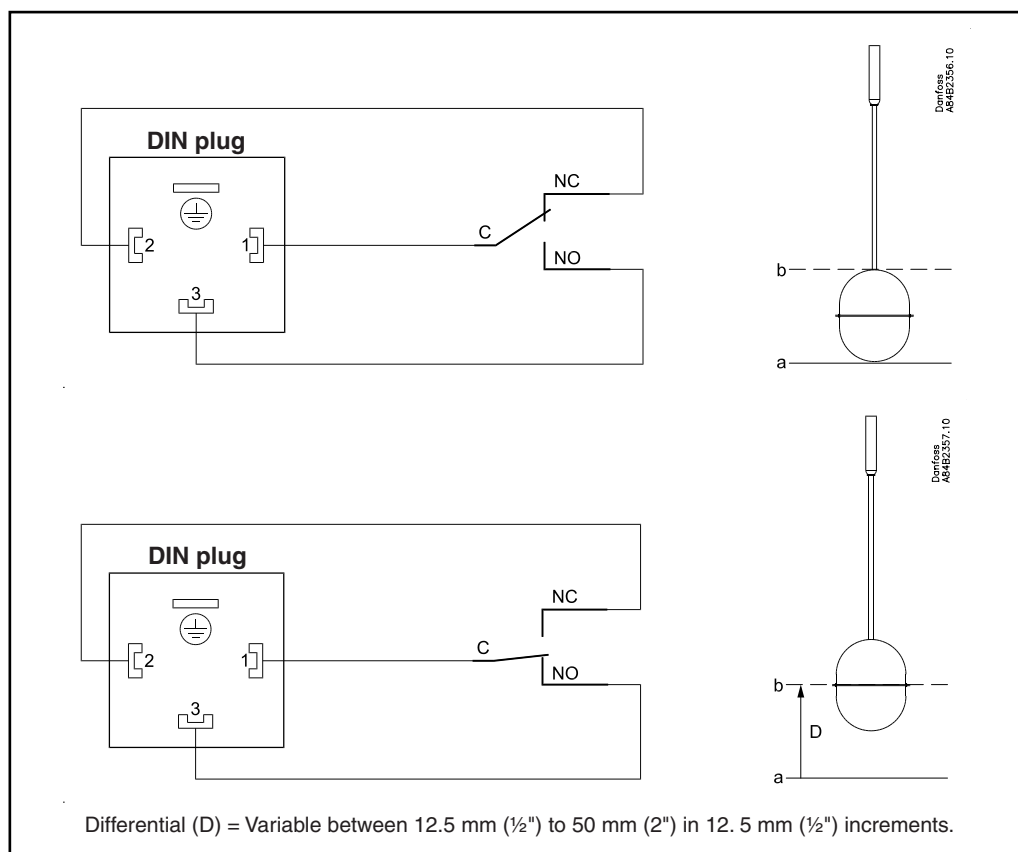
Function

Application

For the control and detection of liquid levels in: -

- Liquid over-feed accumulators.
- Flooded surge drums.
- Flooded shell & tube chillers.
- High and low pressure receivers.
- Inter coolers.
- Use as low/high level safety switch to protect circulating pumps/compressors.

Ordering

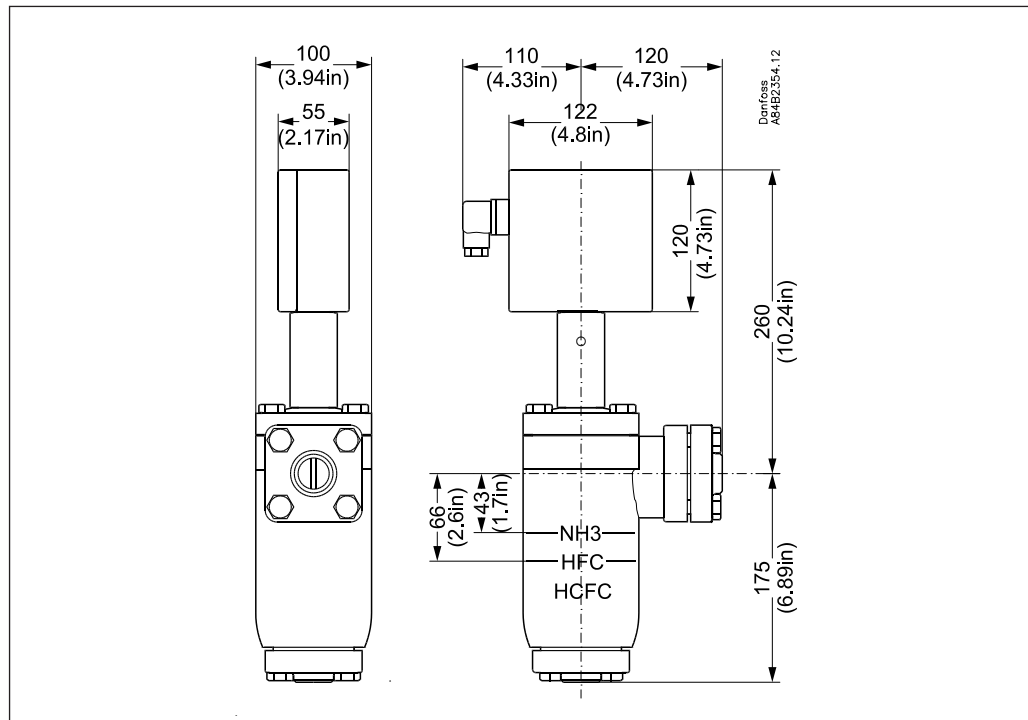
Type	Code No.
AKS 38 Butt Weld, DIN DN 25 (1 in.)	148H3194
AKS 38 Butt Weld, ANSI DN 25 (1 in.)	148H3204
AKS 38 Socket Weld, ANSI DN 20 (3/4 in.)	148H3205
AKS 38 Socket Weld, ANSI DN 25 (1 in.)	148H3206
AKS 38 FPT, NPT DN 20 (3/4 in.)	148H3207
AKS 38 FPT, NPT DN 25 (1 in.)	148H3208

Dimensions

Spare parts

Type	Code no.
Repair kit:	148H3200
Top cover gasket	
O-ring for pressure tube	
Alu. gasket	
Flange gasket	
Locking ring for internal float	
Internal float assembly	148H3203
Electrical switch box	148H3202
Flanges:	
AKS 38 Butt Weld, DIN DN 25 (1 in.)	027N1026
AKS 38 Butt Weld, ANSI DN 25 (1 in.)	027N2023
AKS 38 Socket Weld, ANSI DN 20 (3/4 in.)	027N2012
AKS 38 Socket Weld, ANSI DN 25 (1 in.)	027N2013
AKS 38 FPT, NPT DN 20 (3/4 in.)	027G1007
AKS 38 FPT, NPT DN 25 (1 in.)	027G1008
Please observe: Same flanges as for NRVA 25 and NRVA 32	

Danfoss can accept no responsibility for possible errors in catalogues, brochures and other printed material. Danfoss reserves the right to alter its products without notice. This also applies to products already on order provided that such alterations can be made without subsequential changes being necessary in specifications already agreed. All trademarks in this material are property of the respective companies. Danfoss and the Danfoss logotype are trademarks of Danfoss A/S. All rights reserved.



DK-6430 Nordborg
Denmark