



INDICE

NOVEDADES 2007

	Resumen de las novedades más destacadas introducidas en la gama 2006	2
--	--	---

CORTADORES

	Gama Standard	4
	Gama Profesional	5
	Especialistas en Colocación	6
	Cortaterrazos	8









TRONZADORAS PORTATILES

	Tronzadoras portátiles	10
	Tronzadoras portátiles serie Baticoup y Clio	12





TRONZADORAS - INGLETADORAS DE MESA

	Tronzadoras serie TRONKA - COUPECO	14
	Supertronzadoras Serie MM	15

UTILLAJE MANUAL

	Niveles y plomadas	18
	Recogedores / limpiadores lechada / accesorios	19
	Limpieza de pavimentos	21
	Accesorios de colocación	22
	Protección	24
	Peines, llanas palas y paletas	25
	Cuñas y crucetas de plástico	27
	Trampilla registro sanitarios	28
	Mazos, macetas y cortafrios	29
	Accesorios para perforar cerámica	30
	Foragres - Perforación de gres porcelánico	31
	Pinzas y tenazas	33
	Trazadores, útiles de serrar, recortar y pulir	33



DISCOS DIAMANTE

	Discos de altas prestaciones	35
	Gres y cerámica	36
	Corte materiales de construcción (no abrasivos)	37
	Corte de todos los materiales abrasivos	39
	Corte de piedra abrasiva	39
	Corte de hormigón / asfalto	40
	Platos diamantados cóncavos	41
	Discos abrasivos speedflex	41

MAQUINARIA CONSTRUCCION

	Llenado de juntas y limpieza	43
	Pulidoras de suelos Benepule	44
	Vibradores eléctricos	45
	Reglas vibrantes Beneregle	45
	Vibración del hormigón	46
	Cortadoras de suelo Benesol	46
	Rozadora eléctrica Bi Diam	46
	Perforadoras Benefor	47
	Fratadoras Beneliss	48
	Mezclador eléctrico	48
	Mezclador electrónico	49



FONTANERIA Y SANEAMIENTO

	Curvatubos - cortatubos - rodeles	50
	Llaves lavabo Stillson	50
	Rectificadores	50
	Terrajas	51
	Desatascadores	51

PRODUCTOS TRATAMIENTO TERSOL PARA PAVIMENTOS POROSOS

	Decapantes y limpiadores	52
	Protectores	52
	Ceras	52
	Mantenimiento	52
	Impermeabilizantes	52

PERFILES DE PVC Y METALICOS

	Cantoneras, Juntas de dilatación, Escocia, Perfiles Mono-Capa de PVC	
	Cantoneras y perfiles diversos metálicos	54

MUEBLES EXPOSITORES

	Utilillaje y cortadores	68
	Perfiles	68
	Cortadores, discos y coronas	68
	Expositor para mostrador	69

NOVEDADES 2007

GAMA CEPILLOS



Página 22

AURICULARES ANTIRUIDO



Página 24

LLANAS DE NIVELAR



Página 25

SOPORTE TAMPÓN TAF



Página 21

ANGULAR MAGNÉTICO



Página 24

PLATOS DIAMANTADOS



Página 41

PERFILES (Nuevos modelos y medidas).



Pag.55, Incorporación Perfil de Aluminio e Inox en 15mm. a la Gama Tekno-trim metal.

Pag.56, Incorporación Perfil de Acero Inox Cepillado a la Gama Tekno-angle.

Pag.61, Incorporación Perfil de Aluminio a la Gama Tekno-step metal.

Pag.63, Incorporación Perfil de Aluminio e Inox a la Gama Tekno-list de 10mm. y 25mm.

Pag.64, Incorporación Perfil de Madera Roble americano a la Gama Tekno-nivel.

CORTADORES

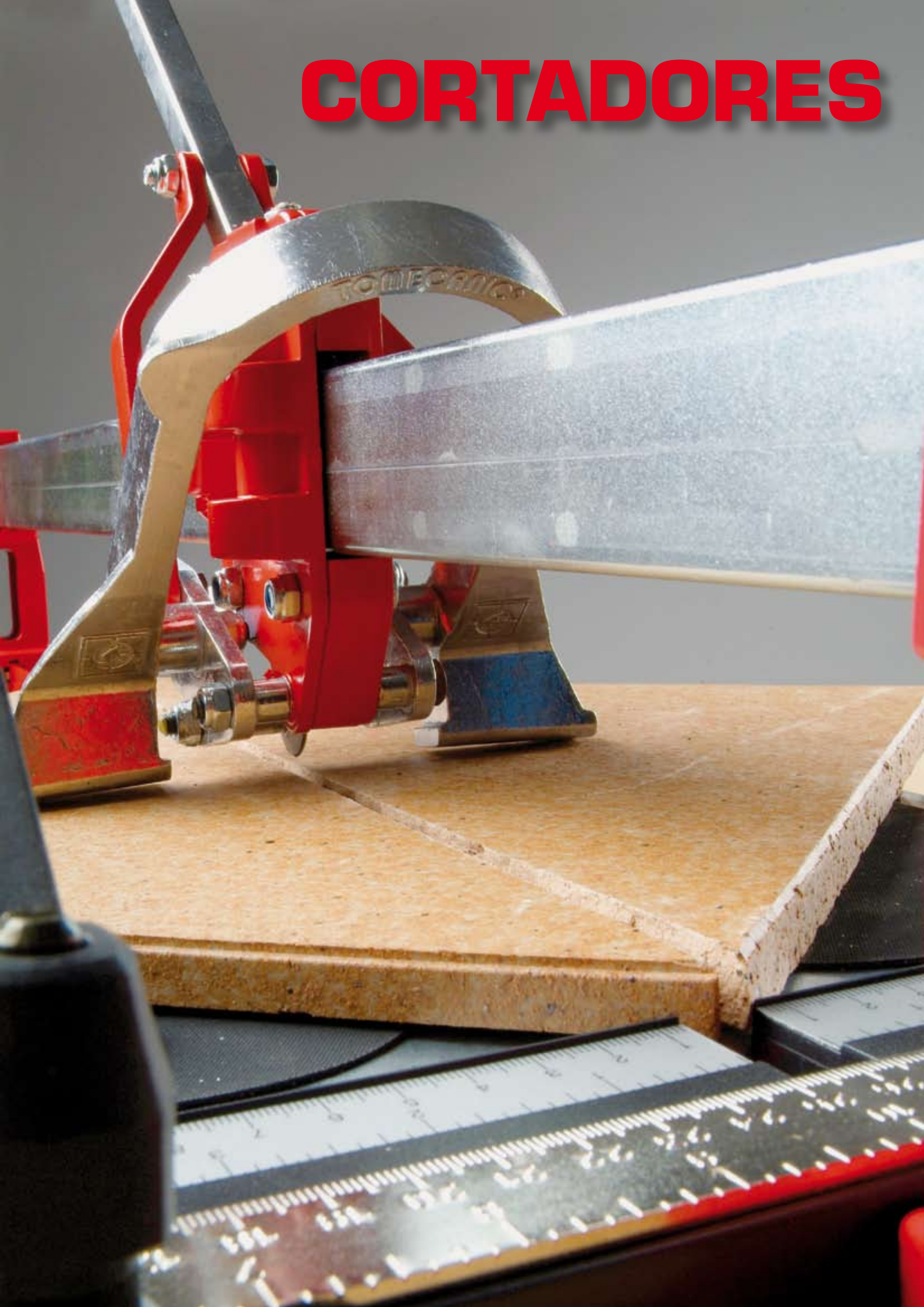

GAMA STANDARD

SERIE SPRINT

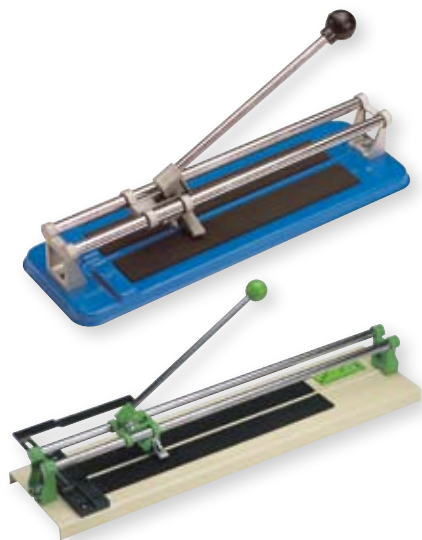

	Ref.						€
EKO 300	831030	6	145 mm	30 x 30 cm	21 x 21 cm	15 mm	11,60
SPRINT EKO 430	831043	6	145 mm	43 x 43 cm	30 x 30 cm	15 mm	18,60
SPRINT 500	831050	6	155 mm	50 x 50 cm	35 x 35 cm	15 mm	27,65
SPRINT 570	831057	6	155 mm	57 x 57 cm	40 x 40 cm	15 mm	30,60

Máquinas destinadas al corte de la cerámica en general. Destaca su sencillez de manejo sus longitudes de corte y un precio al alcance de los aficionados al bricolaje. Incorpora separador móvil.

SERIE STANDARD y STRASS



	Ref.						€
STANDARD 300	311330	6	155 mm	30 x 30 cm	21 x 21 cm	15 mm	28,80
con maleta	312330	2					40,05
STANDARD 400	311340	6	155 mm	40 x 40 cm	28 x 28 cm	15 mm	29,65
con maleta	312340	2					41,95
STANDARD 470	311347	6	155 mm	47 x 47 cm	33 x 33 cm	15 mm	32,50
con maleta	351347	2					43,75
STRASS 500 con maleta	361155	6	155 mm	50 x 50 cm	35 x 35 cm	15 mm	46,55
STRASS 570 con maleta	361165	2	155 mm	57 x 57 cm	40 x 40 cm	15 mm	50,30

Máquinas con una excelente presentación con y sin maleta aptas para el corte de cerámica en general. Sus características se adecuan perfectamente al usuario con necesidades puntuales del corte de la cerámica..

SERIE CUT







	Ref.						€
CUT 330	311433	6	160 mm	33 x 33 cm	23 x 23 cm	15 mm	34,95
con maleta	312433	2					43,95
CUT 400	311440	4	160 mm	40 x 40 cm	28 x 28 cm	15 mm	39,30
con maleta	312440	2					50,95
CUT 470	311447	4	160 mm	47 x 47 cm	33 x 33 cm	15 mm	45,95
con maleta	312447	2					56,60

Máquinas con amplia capacidad de corte en gres y cerámica. Adaptada a las personas que necesitan de un máquina con buen rendimiento gracias a su rodillo de 18 mm.

GAMA PROFESIONAL





SERIE PROCUT

	Ref.						€
PROCUT 430	311543	6	160 mm	43 x 43 cm	30 x 30 cm	15 mm	58,05
con maleta	312543	2					71,80
PROCUT 500	311550	3	215 mm	50 x 50 cm	35 x 35 cm	15 mm	61,45
con maleta	312550	2					79,80
PROCUT 660	311566	2	215 mm	66 x 66 cm	46 x 46 cm	15 mm	75,55
con maleta	312566	2					93,95



Máquinas que se adaptan a las necesidades puntuales del profesional gracias a sus características de longitud, rodil de 18 mm y su separador móvil. Recomendada para el corte de gres y cerámica convencional.

SERIE ROLLERCUT

	Ref.						€
ROLLERCUT 430	311643	4	170 mm	43 x 43cm	30 x 30 cm	15 mm	68,50
ROLLERCUT 500	311650	2					75,30
con maleta	312650	2	170 mm	50 x 50 cm	35 x 35 cm	15 mm	101,25
ROLLERCUT 600	311660	2	170 mm	60 x 60 cm	42 x 42 cm	15 mm	87,70
con maleta	312660	2					113,75



Máquinas con deslizamiento de cabezal mediante dos cilindros de bolas, de gran comodidad para el profesional y todas aquellas personas que requieran una máquina corta-azulejos con buen rendimiento.

GAMA ESPECIALISTAS EN COLOCACIÓN

SERIE CORTAGRES



Guía tope para diagonales



Alargos laterales escamoteables

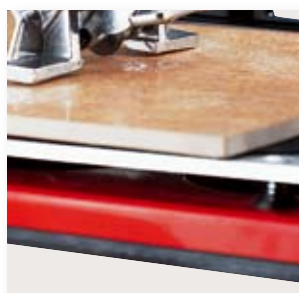

Base sobre muelles

	Ref.						€
CORTAGRES 430	314043	2	230 mm	43 x 43 cm	30 x 30 cm	20 mm	180,00
con maleta	314243	2					212,00
CORTAGRES 600	314060	2	230 mm	60 x 60 cm	42 x 42 cm	20 mm	205,00
con maleta	314260	2					237,00
	536715	1	Guía tope para cortes en diagonal. Para CORTAGRES y SUPERCOUPE.				3,55

Se suministra con 1 rodel \varnothing 6 mm, 1 rodel \varnothing 10 mm y 1 guía tope para diagonales.

Máquinas de elevadas prestaciones técnicas que incorpora desplazamiento del cabezal mediante 6 rodamientos, bases sobre muelles, separador móvil y escuadra graduable.

Destaca por su precisión y rapidez de corte. Recomendada especialmente para el corte del gres porcelánico y aquellos profesionales que requieren de una máquina de altas prestaciones.

GAMA ESPECIALISTAS EN COLOCACIÓN

SERIE SUPERCROUP



Guía tope para diagonales

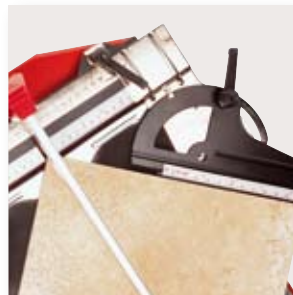

Escuadra graduable



Bases sobre muelles

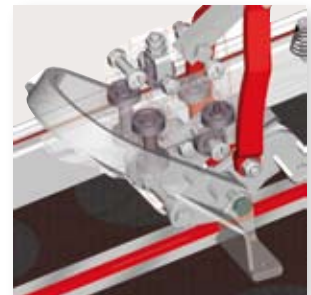

Desplazamiento del cabezal mediante 9 rodamientos



Separador móvil

	Ref.						€
SUPERCROUP 45	2145	1	320 mm	45 x 45 cm	30 x 30 cm	20 mm	294,00
SUPERCROUP 60	2160	1	320 mm	60 x 60 cm	40 x 40 cm	20 mm	303,00
SUPERCROUP 75	2175	1	320 mm	75 x 75 cm	52 x 52 cm	20 mm	333,00
SUPERCROUP 90	2190	1	320 mm	90 x 90 cm	64 x 64 cm	20 mm	387,00
SUPERCROUP 140	311008	1	320 mm	135 x 135 cm	96 x 96 cm	20 mm	649,00

Se suministra con rodel para todo tipo de materiales y 1 guía tope para diagonales.

Máquinas de gran robustez y precisión capaces de cortar los materiales más resistentes como el GRES EXTRUSIONADO, GRES RUSTICO, GRES PORCELANICO y el resto de materiales cerámicos.

RODELES PARA LOS CORTADORES



Ref.			Cortador Serie	€
834605	5	15 x 6 x 1,5 mm	EKO 300 / SPRINT EKO 430	3,85
326015	5	15 x 6 x 2 mm	STANDARD y SPRINT	7,85
185	5	18 x 6 x 4 mm	CUT y PROCUT	8,65
326016	5	22 x 6 x 2 mm	ROLLERCUT	9,10
118/3	5	22 x 6 x 5 mm	SUPERCROUP	9,45
118/2	5	22 x 6 x 5 mm	311065 - 2397	9,05

Los rodeles de TOMECHANIC están fabricados en aleación de carburo de tungsteno obteniendo como resultado unas elevadas prestaciones en dureza y longevidad.

Gracias a sus características son recomendables para el corte de todo tipo de cerámica.

RODELES PARA CORTAGRES



Ref.			€
326017	6	6 x 6 x 2 mm	7,85
326018	6	10 x 6 x 2 mm	8,25
326019	6	18 x 6 x 2 mm	13,35

Rodeles para CORTAGRES compatibles con otros fabricantes.

CORTATERRAZOS



Ref.	Longitud corte	Espesor corte		€
CT00440	44 cm	5,5 cm	33 Kg	312,00
CT00580	58 cm	5,5 cm	57 Kg	385,00

- Corte perfecto al poseer la cuchilla en sus extremos
- Corte con el mínimo esfuerzo el terrazo y baldosas de hormigón hasta 5,5 cms de espesor.

TRONZADORAS ELÉCTRICAS PORTÁTILES



10 TRONZADORAS ELECTRICAS PORTATILES

ACTIVA 180



Ref.	Modelo	€
534009	ACTIVA 180 220/230 V-50 Hz	118,00
534016	ACTIVA 180 115/120 V-60 Hz	118,00

- ✓ Indicada para gres, azulejos y cerámicas.
- ✓ Disco corona continua incluido. Disco de reposición Ref: 822.



180	33	800	2.800	430 x 385 x 250	12	150 mm	22,2 mm

ACTIVA 180 CON MALETA



Ref.	Modelo	€
534020	ACTIVA 180 220/230 V-50 Hz Con Maleta	149,00
534017	ACTIVA 180 115/120 V 60 Hz Con Maleta	149,00

- ✓ Indicada para gres, azulejos y cerámicas.
- ✓ Disco corona continua incluido. Disco de reposición Ref: 822.
- ✓ Disco turbo incluido. Disco de reposición Ref: 580165.

+2 Discos



180	33	800	2.800	430 x 385 x 250	12	150 mm	22,2 mm

ASTRO 800



Ref.	Modelo	€
507590	ASTRO 800	171,00
560105	Caballete metálico articulado	60,00

- ✓ Indicada para gres, azulejos y cerámicas.
- ✓ Mesa de trabajo inoxidable perforada para recuperación y evacuación del agua.
- ✓ **Disco corona continua incluido.** Disco de reposición Ref: 889.



200	45	230	800	2.800	420 x 385 x 240	13	400 mm	22,2 mm

ASTRO 800 CON MALETA



Ref.	Modelo	€
507596	ASTRO 800 Con maleta	198,00
560105	Caballete metálico articulado	60,00
507600	ASTRO 800 115/120 60 Hz Con maleta	198,00

- ✓ Indicada para gres, azulejos y cerámicas.
- ✓ Mesa de trabajo inoxidable perforada para recuperación y evacuación del agua.
- ✓ **Disco corona continua incluido.** Disco de reposición Ref: 889.
- ✓ **Disco turbo incluido.** Disco de reposición Ref: 580170.

+2 Discos



200	45	230	800	2.800	420 x 385 x 240	13	400 mm	22,2 mm

12 TRONZADORAS ELECTRICAS PORTATILES

BATICOUP 200 N3

- ✓ Indicada para gres, azulejos y cerámicas.
- ✓ Mesa de trabajo inoxidable, muy robusta y acabados perfectos.
- ✓ Protector térmico y parada por falta de tensión.
- ✓ **Disco corona continua incluido.**
Disco de reposición Ref: 889.
Disco turbo incluido.
Disco de reposición Ref: 580170.
- ✓ Máquina sobre pies (sin contacto directo con el suelo).
- ✓ **Potencia: 1,2 CV**

+2 Discos

Ref.	Modelo	€
530029	BATICOUP 200	218,00
560105	Caballete metálico articulado	60,00



200	43	230	900	2.800	480 x 470 x 340	17	450 mm	22,2 mm

SERIE CLIO

Ref.	Modelo										€
507542	CLIO 230 SUPER	230	45	220	1.230	2.800	600 x 530 x 330	30	650 mm	25,4 mm	675,00
507543	CLIO 300 SUPER	300	75	220	2.000	2.800	600 x 530 x 330	34	650 mm	25,4 mm	726,00
560105	Caballete metálico articulado										60,00

- ✓ Indicada para barro cocido, gres, azulejos, mármol y otros materiales de la obra.
- ✓ Mesa de trabajo inox, muy robusta y acabados perfectos.
- ✓ Protector térmico y parada por falta de tensión.
- ✓ **Disco diamante NO INCLUIDO.**





TRONZADORAS de MESA

14 TRONZADORAS INGLETADORAS DE MESA

TRONKA 710

Ref.	Modelo	VOLT	WATT				máx	mm		L x A x H cm.	kg	€
500471	TRONKA 710	230 V - 50 Hz	800	2.800	230	25,4 mm	710 mm	60	95 x 63 x 46	80	550,00	



- ✓ Sobre 4 patas desmontables.
- ✓ Cabezal montado sobre rodamiento.
- ✓ Con un disco TURBO \varnothing 230 (para materiales no abrasivos + 1 disco gratis \varnothing 230 de banda continua para cerámica).
- ✓ Protector térmico y parada por falta de tensión.
- ✓ Cabezal abatible a 45° para ingletes.
- ✓ **Disco corona continua incluido.**
Disco de reposición Ref: 834.
- ✓ **Disco turbo incluido.**
Disco de reposición Ref: 835.

+2 Discos



COUPECO

Ref.	Modelo	VOLT	WATT				máx	mm		L x A x H cm.	kg	€
T00019G	COUPECO 230 V	230 V - 50 Hz	2.200	2.800	300/350	25,4 mm	780 mm	115	120 x 63 x 55	80	1.165,00	
T00019H	COUPECO 380 V	380 V - 50 Hz	3.000	2.800	300/350	25,4 mm	780 mm	115	120 x 63 x 55	80	1.165,00	
T00019A	COUPECO 115 V	115 V - 60 Hz	2.200	2.800	300/350	25,4 mm	780 mm	115	120 x 63 x 55	80	1.165,00	



- ✓ Sobre 4 patas desmontables.
- ✓ El carro se desliza mediante cojinetes de bolas.
- ✓ Escuadra orientable.
- ✓ Protector térmico y parada por falta de tensión.
- ✓ Disco de diamante \varnothing 300-350 mm - **No incluido.**
- ✓ Cabezal disco regulable en altura y abatible a 45° para ingletes.



SERIE MM

Ref.	Modelo	VOLT	WATT				máx	mm	L x A x H cm.	kg	€
5001410	MM 1000	230 - 50 Hz	2.200	2.800	350	25,4 mm	1.000 mm	110	140 x 66 x 77	120	1.985,00
5001420	MM 1000	400 - 50 Hz	3.000	2.800	350	25,4 mm	1.000 mm	110	140 x 66 x 77	120	1.985,00
5001405	MM 1000	115 - 60 Hz	2.200	2.800	350	25,4 mm	1.000 mm	110	140 x 66 x 77	120	1.985,00
5001610	MM 1200	230 - 50 Hz	2.200	2.800	350	25,4 mm	1.200 mm	110	160 x 66 x 77	160	2.085,00
5001620	MM 1200	400 - 50 Hz	3.000	2.800	350	25,4 mm	1.200 mm	110	160 x 66 x 77	160	2.085,00
5001605	MM 1200	115 - 60 Hz	2.200	2.800	350	25,4 mm	1.200 mm	110	160 x 66 x 77	160	2.085,00
5001810	MM 1500	230 - 50 Hz	2.200	2.800	350	25,4 mm	1.500 mm	110	197 x 66 x 77	180	2.880,00
5001820	MM 1500	400 - 50 Hz	3.000	2.800	350	25,4 mm	1.500 mm	110	197 x 66 x 77	180	2.880,00
5001805	MM 1500	115 - 60 Hz	2.200	2.800	350	25,4 mm	1.500 mm	110	197 x 66 x 77	180	2.880,00
5001825	MM 1500 S	400 - 50 Hz	4.000	2.800	450	25,4 mm	1.500 mm	180	197 x 88 x 77	210	3.380,00
17MM000	MESA COMPLEMENTARIA DE RODILLOS PARA SERIE MM										340,00

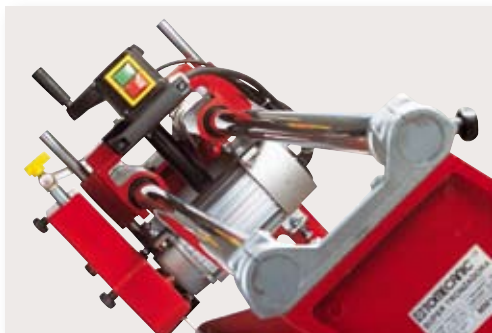

- ✓ El cabezal se desliza mediante cojinetes de bolas lineales sobre las barras cromadas y rectificadas de 40 mm y 50 mm en modelo MM 1500 S.
- ✓ Cabezal inclinable de 0° a 45°.
- ✓ Altura regulable del disco mediante volante giratorio.
- ✓ Bomba de agua eléctrica sumergida en la cubeta.
- ✓ Incluye mesa complementaria de chapa.
- ✓ Altura de corte: 110 mm y 180 mm en el modelo MM 1500 S.
- ✓ Sistema de seguridad eléctrico según normas CE.
- ✓ Disco no incluido.



16 SUPER TRONZADORAS MM



BIG CUT



BIG CUT XL



- ✓ El cabezal se desliza mediante cojinetes de bolas lineales sobre las barras cromadas y rectificadas: 50 mm.
- ✓ Altura regulable del disco mediante volante giratorio.
- ✓ Bomba de agua eléctrica sumergida en la cubeta.

- ✓ Incluye mesa complementaria de chapa.
- ✓ Altura de corte: 150 mm.
- ✓ Sistema de seguridad eléctrico según normas CE.
- ✓ **Disco no incluido.**

BIG CUT

Ref.	Modelo	VOLT	WATT								€
					(mm)	(mm)	máx	mm	L x A x H cm.	kg	
500203	MM 2000	400 - 50 Hz	4.000	1.400	450	25,4 mm	2.000 mm	150	275 x 66 x 77	245	5.640,00
500200	MM 2000	230 - 50 Hz	2.200	2.800	450	25,4 mm	2.000 mm	150	275 x 66 x 77	245	4.790,00
17MM000	MESA COMPLEMENTARIA DE RODILLOS PARA SERIE MM										340,00

- ✓ Control del corte mediante tracción de correa del cabezal accionado por un volante ubicado en el "puesto del operador".

BIG CUT XL

Ref.	Modelo	VOLT	WATT								€
					(mm)	(mm)	máx	mm	L x A x H cm.	kg	
500205	MM 2000XL	400 - 50 Hz	4.000	1.400	450	25,4 mm	2.000 mm	150	275 x 66 x 77	266	6.715,00
500210	MM 2000XL	230 - 50 Hz	2.200	2.800	450	25,4 mm	2.000 mm	150	275 x 66 x 77	266	5.760,00
17MM000	MESA COMPLEMENTARIA DE RODILLOS PARA SERIE MM										340,00

- ✓ Control de corte mediante tracción de correa del cabezal, accionada por un motor reductor de control electrónico.

HERRAMIENTAS Y UTILLAJE MANUAL

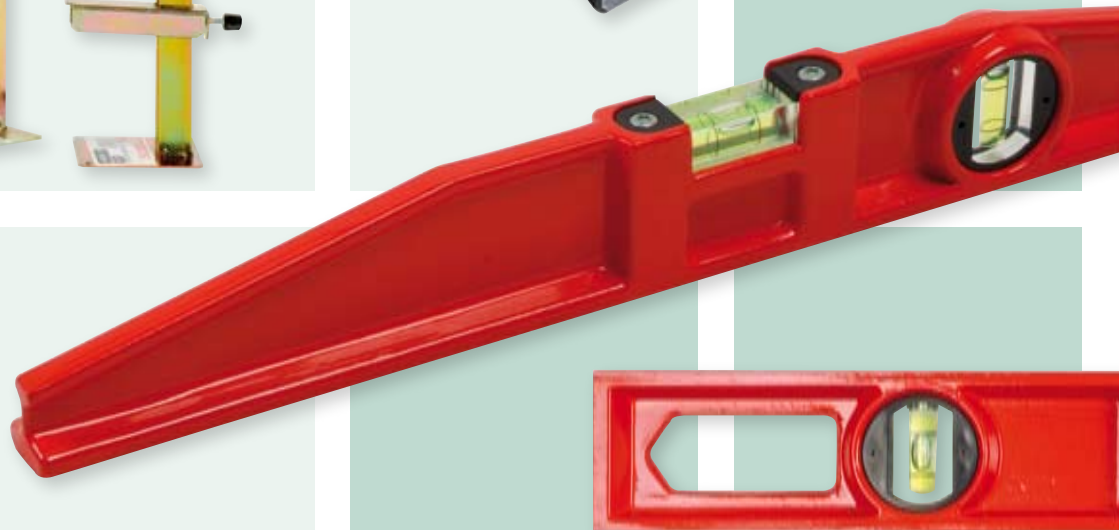

NIVELES

NIVELES DE ALTA CALIDAD

- ✓ Niveles profesionales de fundición de aluminio
- ✓ Alta precisión: 0,5 mm.
- ✓ Dureza 95 / 105 kg. / Mm2
- ✓ Refuerzo central en H que asegura una mayor rigidez
- ✓ Tipo ala de avión: ángulos redondeados (*mayor confort de utilización y manipulación*)
- ✓ Gama completa de 40 a 100 cm
- ✓ Burbuja irrompible - garantía: 10 años
- ✓ Bases rectificadas

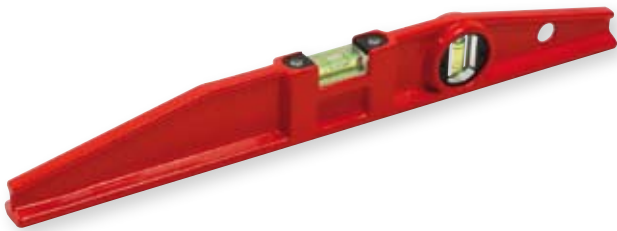

Ref.	Descripción			€
304040	Nivel antichoc tipo ala de avión	40 cm	10	24,65
304050	Nivel antichoc tipo ala de avión	50 cm	10	27,15
304060	Nivel antichoc tipo ala de avión	60 cm	10	30,35
304080	Nivel antichoc tipo ala de avión	80 cm	10	36,20
304100	Nivel antichoc tipo ala de avión	100 cm	10	40,90



304042	Nivel antichoc tipo ala de avión <i>magnético</i>	40 cm	10	36,25
304052	Nivel antichoc tipo ala de avión <i>magnético</i>	50 cm	10	39,80
304062	Nivel antichoc tipo ala de avión <i>magnético</i>	60 cm	10	43,10
304082	Nivel antichoc tipo ala de avión <i>magnético</i>	80 cm	10	52,35
304102	Nivel antichoc tipo ala de avión <i>magnético</i>	100 cm	10	62,90



304140	Nivel antichoc rectangular	40 cm	10	28,90
304150	Nivel antichoc rectangular	50 cm	10	33,70
304160	Nivel antichoc rectangular	60 cm	10	37,75
304180	Nivel antichoc rectangular	80 cm	10	40,80

PLOMADAS

PLOMADAS

- ✓ Plomada y nuez de acero zincado anticorrosivo.
- ✓ Opción nuez metálica magnética.
- ✓ Longitud cuerda: 5 m.



Ref.	Descripción			€
304500	Plomada de acero-nuez metálica	500 gr.	5	7,95
304700	Plomada de acero-nuez metálica	700 gr.	5	9,40
304900	Plomada de acero-nuez metálica	1.000 gr	5	11,25
304505	Plomada de acero-nuez metálica <i>magnética</i>	500 gr.	5	14,30
304705	Plomada de acero-nuez metálica <i>magnética</i>	700 gr.	5	15,65
304905	Plomada de acero-nuez metálica <i>magnética</i>	1.000 gr.	5	17,40

RECOGEDORES - LIMPIADORES DE LECHADA



915

902

349202

Ref.	Descripción			€
902	Llana goma especial montura inoxidable.	245 x 100 mm	6	11,95
915	Llana de rejuntar base de resina Especial para juntas Epoxy y similares	260 x 100 mm	6	13,50
349202	Espátula para alisar juntas		6	4,10

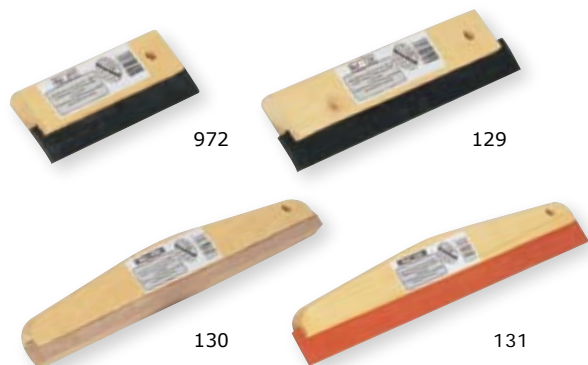

972

129

130

131

Ref.	Descripción			€
972	Regleta goma montura madera	180 mm	12	2,00
129	Regleta goma montura madera	270 mm	12	2,70
130	Regleta doble espuma con acoplamiento para mango	440 mm	12	3,80
131	Regleta goma calidad superior con acoplamiento para mango	450 mm	12	4,40



323020

323020	Regleta para azulejos montura ABS	280 mm	10	4,85
--------	-----------------------------------	--------	----	------



191

194/1

194/2

194/3

194/4

349320

191	Regleta metálica. Goma espuma	650 mm	6	24,35
194/1	Regleta doble espuma (montura metálica)	350 mm	12	2,95
194/2	Regleta doble espuma (montura metálica)	430 mm	12	3,20
194/3	Regleta doble espuma (montura metálica)	540 mm	12	3,95
194/4	Regleta doble espuma (montura metálica)	750 mm	12	7,95

349320	Rascador universal	127 x 550 mm	6	14,60
--------	--------------------	--------------	---	-------

349019	Mango madera	1,2 m	12	1,80
--------	--------------	-------	----	------

RECOGEDORES - LIMPIADORES DE LECHADA



323130



323140



323150



323160



323605



323610

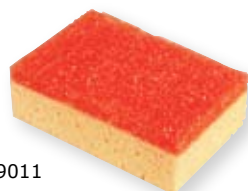

349011



349010



349016



349013

Ref.	Descripción			€
323130	Talocha con goma esponja naranja espesor 15 mm	205 x 135 mm	6	7,05
323140	Talocha de ángulo con goma esponja naranja	350 x 70 mm	3	10,50
323150	Talocha con goma esponja naranja espesor 15 mm	400 x 70 mm	3	8,15
323160	Talocha de frotar con esponja, espesor 40 mm	350 x 120 mm	3	8,20

Ref.	Descripción			€
323605	Talocha de enmasillar espuma dura	280 x 140 mm	6	5,80
323610	Talocha con esponja amarilla	280 x 140 mm	6	5,90

349010	Esponja 200 x 100 x 65		18	1,40
349011	Esponja 200 x 100 x 65	Mixta	18	1,95
270601	Estopa para limpieza junta	aprox. 30 m ²	1	17,15

Ref.	Descripción			€
349016	Kit de limpieza con dos talochas	10 litros (cubeta)	1	35,30
349013	Kit de limpieza sobre ruedas. 2 rodillos, reja de separación, 2 talochas	22 litros (cubeta)	1	53,75

LIMPIEZA DE PAVIMENTOS



Ref.	Descripción			€
909	Llana inox con 2 tampones negro y blanco (nylon y poliester)	250 x 115 mm	3	13,45
910	Llana inox con 3 tampones; verde, salmón y blanco	250 x 115 mm	3	15,90



Ref.	Descripción			€
270003	Porta tampón TAF adhesivo para mango Ref. 908	225 x 95 mm	1	9,70
270004	Mango metal cromado ø 22 mm	130 cm	1	2,85

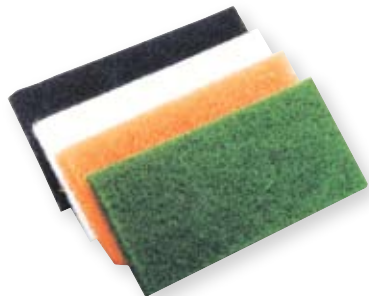

Ref.	Descripción			€
904/1	Tampón TAF negro fibra nylon muy abrasivo	250 x 115 mm	5	2,85
904/2	Tampón TAF verde fibra nylon abrasiva	250 x 115 mm	5	2,85
904/3	Tampón TAF salmon fibra polyester semi-suave	250 x 115 mm	5	2,85
904/4	Tampón TAF blanco fibra polyester suave	250 x 115 mm	5	2,85



Consultar otros diámetros de discos TAF

Ref.	Discos TAF para JUNTASOL	∅		€
280511	Disco TAF negro fibra nylon muy abrasivo (cartón 5 unidades)	406	1	47,70
280512	Disco TAF verde fibra nylon abrasiva (cartón 5 unidades)	406	1	47,70
280513	Disco TAF salmón fibra polyester semi-suave (cartón 5 unidades)	406	1	43,35
280514	Disco TAF blanco fibra polyester suave (cartón 5 unidades)	406	1	45,90



Consultar otros diámetros de discos TAF

Ref.	Discos TAF para JUNTASOL SUPER 50	∅		€
214170	Disco TAF negro fibra nylon muy abrasivo (cartón 5 unidades)	505	1	75,60
214155	Disco TAF verde fibra nylon abrasivo (cartón 5 unidades)	505	1	68,65
214165	Disco TAF rojo fibra nylon suave (cartón 5 unidades)	505	1	66,95
214160	Disco TAF blanco fibra nylon muy suave (cartón 5 unidades)	505	1	66,95

LIMPIEZA DE PAVIMENTOS



Ref.	Descripción			€
270005	Cepillo barrendero de fibra (Completo mango + garra)	500 x 65 mm	6	8,20

NUEVO



270006	Cepillo manual de fibra (sin mango)	215 x 52 mm	12	2,15
--------	-------------------------------------	-------------	----	------



270007	Cepillo buque de fibra (sin mango)	220 x 60 mm	12	3,05
--------	------------------------------------	-------------	----	------



270008	Cepillo con mango puas acero latonado	290 x 30 mm	12	1,80
--------	---------------------------------------	-------------	----	------



270009	Cepillo sin mango puas acero latonado	180 x 50 mm	12	2,15
--------	---------------------------------------	-------------	----	------



270010	Mango madera roscado ø 22 mm para cepillo buque		12	1,95
--------	---	--	----	------

ACCESORIOS PARA LA COLOCACIÓN



Ref.	Descripción	Características		€
135/1	Aplanador suela goma, haya barnizada	300 x 115 mm	1	18,80
135/2	Aplanador suela goma, haya barnizada	400 x 145 mm	1	25,35

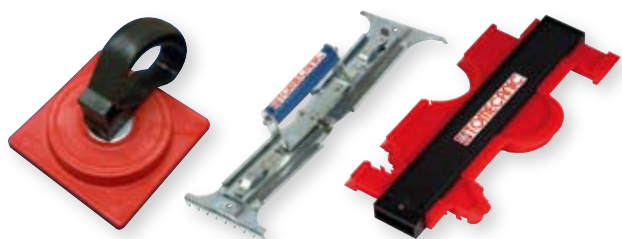

Ref.	Descripción		€
991	Ventosa para todo uso - Máximo 50 Kgs.	3	13,90
349961	Transportador de baldosas (de 30 a 50 cm)	1	12,85
349068	Plantilla de formas	3	13,30

ACCESORIOS PARA LA COLOCACIÓN



Ref.	Descripción			€
349063	Par de zuecos con puntas	365 x 190 mm	1	21,05



349064	Par de zuecos lisos	365 x 190 mm	1	20,20
--------	---------------------	--------------	---	-------



349065	Par de zuecos estriados	365 x 190 mm	1	18,05
--------	-------------------------	--------------	---	-------



993	Mezclador	long. 60 cm	10 mm	6	7,05
994	Mezclador helicoidal	long. 50 cm	10 mm	6	12,05
503100	Mezclador diámetro 120 mm	long. 60 cm	M14	2	22,15
503102	Mezclador diámetro 140 mm	long. 60 cm	M14	6	27,40
503101	Mezclador diámetro 160 mm	long. 60 cm	M14	2	32,80

994

993

503100
503102
503101



Ref.	Descripción	Ø		€
349901	Clavo hexagonal de sujeción 250 mm Acero templado	10 mm	25	3,05

ACCESORIOS PARA LA COLOCACIÓN



Ref.	Descripción	€
022100	Juego de angulares magnéticos	12,95

022150	Juego de 2 soportes regla	15 cms	1	15,75
022300	Juego de 2 soportes regla	30 cms	1	17,70
022500	Juego de 2 soportes regla	50 cms	1	19,50

990	Pistola para rellenar juntas	330 mm / 750 c.c.	1	28,35
990B	Boquilla recambio para Ref. 990	330 mm / 750 c.c.	1	1,25
349250	Kit de 2 mangas de rejuntar + 3 boquillas		1	16,25

PROTECCION



	Descripción		
139	Rodillera profesional caucho calidad superior	12	7,40
139/2	Rodillera profesional caucho calidad superior (en blister)	8	8,45
530515	Recambio goma rodillera	50	0,75
832505	Par de rodilleras (en blister)	6	10,45
832591	Rodillera goma (antes Ref. 308)	12	4,40
352510	Par de rodilleras (en blister)	6	14,10

560225	Auriculares antiruido acolchado cumple con directiva 89/686/CEE y norma EN352	1	8,40
560000	Kit seguridad (gafas de protección+ mascarilla anti-polvo)	1	5,30

PEINES, LLANAS

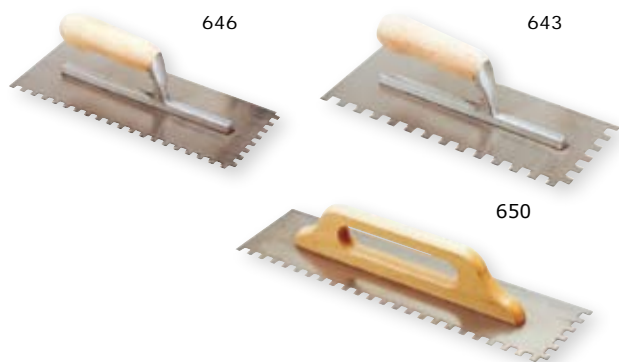

646

643

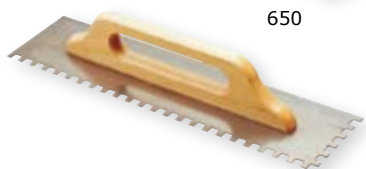

650



649-659

648

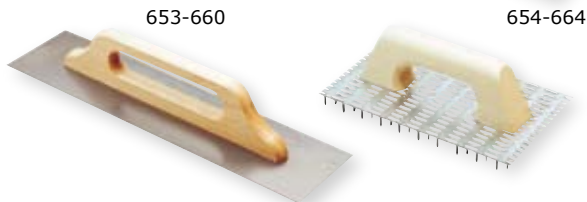

653-660



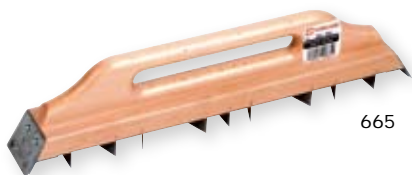



654-664



665



NUEVO

Ref.	Descripción	mm	Tipo	Dimensiones		€
642	Dentado	3 x 3		280 x 120 mm	5	6,65
643	Dentado	5 x 5		280 x 120 mm	5	6,65
644	Dentado	7 x 7		280 x 120 mm	5	6,65
645	Dentado	8 x 8		280 x 120 mm	5	6,65
646	Dentado	10 x 10		280 x 120 mm	5	6,65
650	Dentado	10 x 10		480 x 120 mm	5	14,05











648	Llana rectangular			280 x 120 mm	5	6,40
649	Llana rectangular			300 x 160 mm	12	6,95
659	Llana rectangular inox.			300 x 160 mm	6	10,55
660	Alisador suizo inox.			480 x 120 mm	6	17,40
653	Alisador suizo morteros mono capa			480 x 120 mm	6	15,10

654	Raspador mortero monocapa (15 mm)			240 x 145 mm	6	9,05
664	Raspador mortero monocapa (8 mm)			240 x 145 mm	6	8,50

665	Raspador acero para yeso (11 hojas)			470 x 70 mm	2	22,95
-----	-------------------------------------	--	--	-------------	---	-------

331450	Llana de nivelar inox.			450 x 120/90 mm	1	21,95
331550	Llana de nivelar inox.			550 x 120/90 mm	1	23,55



689/4	Espátula peine	4 mm		194x 86 mm	6	0,80
689/5	Espátula peine	5 mm		194x 86 mm	6	0,80
683/3	Espátula peine madera	3 mm		185x 130 mm	6	2,30
690/4	Espátula peine madera	4 mm		185x 130 mm	6	2,30
690/5	Espátula peine madera	5 mm		185x 130 mm	6	2,30
683/6	Espátula peine madera	6 mm		185x 130 mm	6	2,30
683/9	Espátula peine madera	9 mm		185x 130 mm	6	2,30
691/4	Espátula peine madera	4 mm		250x 130 mm	6	3,60
691/5	Espátula peine madera	5 mm		250x 130 mm	6	3,60
684/6	Espátula peine madera	6 mm		250x 130 mm	6	3,60
684/9	Espátula peine madera	9 mm		250x 130 mm	6	3,60

PEINES, LLANAS, PALAS Y PALETAS



Ref.	Descripción	Características		€
651	Paleta Catalana	165 x 120 mm	12	9,85
652	Paleta Norte	180 x 116 mm	12	10,15
670	Paleta Sevilla	190 x 114 mm	12	9,95
671	Paleta Madrid	190 x 105 mm	12	8,85
672	Paletín punta aguda	125 x 75 mm	12	6,85
673	Paletín punta redonda	130 x 75 mm	12	6,85
674	Paleta Solador redonda	120 x 105 mm	12	9,75
675	Paleta Solador recta	125 105 mm	12	9,75
676	Paletín hoja laurel	140 x 60 mm	12	6,85
331680	Paletín inox. ángulos internos	200 x 120 mm x 0,4 mm	6	10,95



Ref.	Descripción	Dimensiones		€
050001	Talocha de plástico Punta	27 x 18 cm	6	3,20
050005	Talocha de plástico Rectangular	27 x 18 cm	6	3,40
050006	Talocha de plástico Rectangular	27 x 35 cm	6	4,60



303200	Pala cuadrada / mango anilla madera	6	13,20
303205	Pala cuadrada / mango muleta	6	12,30
303210	Pala punta / mango anilla madera	6	12,45
303215	Pala punta / mango muleta	6	11,65

CUÑAS Y CRUCETAS DE PLASTICO

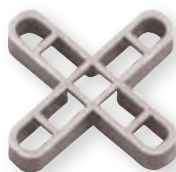

Ref.	Descripción	Unidades		€
855/2	Cuñas plásticas	250	12	2,00
532	Crucetas 1 mm	250	12	1,55
533	Crucetas 1,5 mm	100	12	1,45
534	Crucetas 2 mm	250	12	1,60
534/1	Crucetas 2 mm	500	6	2,60
856/2	Crucetas 3 mm	250	12	1,85
856/1	Crucetas 3 mm	500	6	3,05
857/2	Crucetas 5 mm	250	12	2,30
857/1	Crucetas 5 mm	500	6	3,95
1038/2	Crucetas 7 mm	250	12	4,95
1038/4	Crucetas 7 mm	1.000	6	16,35
858/2	Crucetas 8 mm	100	12	1,95
530524	Crucetas 8 mm	1.000	6	11,85
531/1	Crucetas 10 mm	100	6	4,50
531/3	Crucetas 10 mm	500	6	17,70
1026/2	Crucetas 3 mm (forma T)	250	6	3,45
1027/2	Crucetas 5 mm (forma T)	250	6	3,60
1028/2	Crucetas 7 mm (forma T)	250	6	5,35
861/2	Crucetas 8 mm (forma T)	100	6	2,50
1029/1	Crucetas 10 mm (forma T)	100	6	5,20
324202	Crucetas PVC para pavé de vidrio	20	6	6,40

Consultar precios y disponibilidad para embalajes superiores

MERCHANDISING "OPEN PACK" TOMECANIC

MENOS MANIPULACION - MAS ECONOMICO - MAYOR RENTABILIDAD

El OPEN PACK se define como un producto suministrado en embalaje de cartón pre-recortado. Al quitar la zona pre-recortada nos queda un pequeño contenedor con el material a la vista, ordenado y ocupando un menor espacio.



Atención: Por razones informáticas, conviene pedir cantidades de OPEN PACK, no de bolsas.

Ejemplo:

Al pedir 1 OPEN PACK ref. 892404, recibirá una caja de cartón con 36 bolsas de 250 cuñas recuperables.

El Cartón OPEN PACK, tiene su propio código de barras, este le permitirá hacer una gestión correcta de sus compras. En el interior del OPEN PACK, cada bolsa lleva otro código de barras que le facilitará la gestión de sus ventas.

Composición Código Barras por caja OPEN PACK			Composición Código Barras para bolsas			DESCRIPCION	Cantidad por OPEN PACK	PVP caja OPEN PACK	PVP aproximado por BOLSA
Código Proveedor	Ref. Comercial	Clave	Código Proveedor	Ref. Comercial	Clave			Euros	Euros
322167	892404	8	322167	324204	8	Cuña recuperable de 1 a 5 mm. Saco 250 u.	36	48,60	1,35
322167	892470	3	322167	324270	3	Cruceta de 2 mm. Saco 200 unidades	54	52,95	0,98
322167	892472	7	322167	324272	7	Cruceta de 3 mm. Saco 200 unidades	40	43,30	1,08
322167	892474	1	322167	324274	1	Cruceta de 4 mm. Saco 200 unidades	48	52,50	1,09
322167	892476	5	322167	324276	5	Cruceta de 5 mm. Saco 200 unidades	40	50,95	1,27
322167	892478	9	322167	324278	9	Cruceta de 8 mm. Saco 100 unidades	40	49,45	1,24
322167	892479	6	322167	324279	6	Cruceta de 10 mm. Saco 100 unidades	40	58,35	1,46

TRAMPILLA REGISTRO SANITARIOS

SERIE UNIVERSAL



Ref.	Descripción		€
380040	Kit magnético trampilla de registro de sanitarios	6	5,95

SERIE NOVATRAP



Con protección bicromatado por electrolisis, reversible para colocación con cemento cola o mortero.

Ref.	Combinación de azulejos por trampilla	L x A*		€
110003	4 de 15 x 15 o 1 de 30 x 30 cm	30,5 x 30,5	1	29,95
110019	4 de 10 x 10 o 2 de 20 x 20 cm	40,4 x 20,2	1	31,20
110023	8 de 10 x 20 ó 4 de 20 x 20 cm 2 de 20 x 40 ó 1 de 40 x 40	40,4 x 40,4	1	41,70
110024	6 de 10 x 20 ó 4 de 15 x 20	30,3 x 40,4	1	36,75

* Medidas interiores del cuadro en centímetros.

SERIE PRACTIC



Plato en acero galvanizado.
Cuadro con protección electrozincada.
Para colocación con cemento cola únicamente.

Ref.	Combinación de azulejos por trampilla	L x A*		€
380011	4 de 15 x 15 o 1 de 30 x 30 cm	30,5 x 30,5	1	22,65
380014	3 de 10 x 20 ó 1 de 20 x 30 cm	30,2 x 20,2	1	18,65
380015	8 de 10 x 20 ó 4 de 20 x 20 cm 1 de 40 x 40	40,4 x 40,4	1	29,60

* Medidas interiores del cuadro en centímetros.

MAZOS - MACETAS - CORTAFRIOS



Ref.	Descripción	∅	kg		€
153/0	Mazo de goma plano - cóncavo	45 mm	250 grs	4	4,05
153/1	Mazo de goma plano - cóncavo	60 mm	500 grs	6	5,35
153/2	Mazo de goma plano - cóncavo	90 mm	1.000 grs	4	7,80
153/6	Mazo de goma blanca	60 mm	500 grs	6	7,35
834821	Mazo de goma	60 mm	500 grs	6	3,70

010700	Maceta Española mango madera	750 grs	6	10,55
011000	Maceta Española mango madera	1.000 grs	6	11,80
011400	Maceta Española mango madera	1.250 grs	4	13,35

011100	Maceta Española mango de fibra	1.000 grs	4	14,95
011250	Maceta Española mango de fibra	1.250 grs	4	16,90

021000	Maceta Cuadrada mango madera	1.000 grs	4	11,50
021250	Maceta Cuadrada mango madera	1.250 grs	4	13,65
021500	Maceta Cuadrada mango madera	1.500 grs	4	15,30

031500	Maceta Cuadrada mango de fibra	1.500 grs	4	16,95
--------	--------------------------------	-----------	---	-------

Ref.	Descripción		€
080200	Puntero 200 mm Acero templado	10	5,20
080250	Puntero 250 mm Acero templado	10	5,40
080300	Puntero 300 mm Acero templado	10	6,30
080350	Puntero 350 mm Acero templado	10	7,40
080400	Puntero 400 mm Acero templado	10	8,20
070200	Cortafríos 200 mm Acero templado	10	5,10
070250	Cortafríos 250 mm Acero templado	10	5,75
070300	Cortafríos 300 mm Acero templado	10	6,15
070350	Cortafríos 350 mm Acero templado	10	6,55
070400	Cortafríos 400 mm Acero templado	10	7,40

ACCESORIOS PARA PERFORAR CERAMICA (Azulejos, barro cocido)



Ref.	Descripción	Presentación		€
349018	KIT DE CORONAS PERFORADORAS Compuesto de: · 5 coronas de carburo de tungsteno \varnothing 33 - 53 - 67 - 73 - 83 · 1 Soporte corona · 1 Broca centradora · 1 Lima media caña de carburo de tungsteno	Maleta	2	64,60



Ref.	Descripción	Presentación		€
518075	KIT DE CORONAS PERFORADORAS Compuesto de: · 4 coronas de carburo de tungsteno \varnothing 33 - 53 - 67 - 73 · 1 Soporte corona · 1 Broca centradora	Blister	4	35,70



Ref.	Descripción	\varnothing		€
349080	Corona de carburo de tungsteno	33 mm	4	8,30
349081	Corona de carburo de tungsteno	53 mm	4	11,30
349082	Corona de carburo de tungsteno	67 mm	4	12,15
349083	Corona de carburo de tungsteno	73 mm	4	13,75
349084	Corona de carburo de tungsteno	83 mm	4	15,15
349085	Broca centradora		6	6,15
349086	Soporte corona		6	7,60



Ref.	Descripción	Características		€
116/2	Broca extensible de carburo de tungsteno adaptable a taladro, con una cuchilla de recambio.	de \varnothing 22 a \varnothing 100	3	12,80

FORAGRES - PERFORACIÓN DE GRES Y PORCELANICO



Ref.	Descripción	€
349087	Guia FORAGRES en ABS con ventosa	22,10



Ref.	Descripción	€
349089	Guia FORAGRES metálica con ventosa	40,70



Ref.	Descripción	€
349088	Depósito 5 l. a presión para refrigeración coronas	34,90



349131

KIT FORAGRES CON MALETA		
Ref.	Descripción	€
349090	KIT FORAGRES CON AGUA Compuesto de: · 6 coronas diamantadas de agua \varnothing 27 - 35 - 45 - 55 - 65 - 75 mm. · 1 Guia FORAGRES universal · 1 Maletín	315,00
349131	KIT FORAGRES CON AGUA Compuesto de: · 4 coronas diamantadas de agua \varnothing 6 - 8 - 10 - 18 mm. · 1 Maletín	66,65
349091	KIT FORAGRES EN SECO Compuesto de: · 6 coronas diamantadas en seco \varnothing 27 - 35 - 50 - 60 - 65 - 75 mm. · 1 Guia FORAGRES universal · 1 Maletín · 1 Adaptador M14 a \varnothing 10 mm.	386,00

FORAGRES - PERFORACIÓN DE GRES Y PORCELANICO

CORONAS CORTE CON AGUA



Corona de agua				
Ref.	Profundidad máxima	∅		€
349120	30 mm	6 mm	1	10,65
349121	30 mm	8 mm	1	12,10
349122	30 mm	10 mm	1	14,95
349123	30 mm	18 mm	1	22,05
349124	30 mm	27 mm	1	32,95
349125	30 mm	35 mm	1	42,25
349126	30 mm	45 mm	1	47,40
349127	30 mm	55 mm	1	57,70
349128	30 mm	65 mm	1	68,00
349129	30 mm	67 mm	1	70,05
349130	30 mm	75 mm	1	78,30

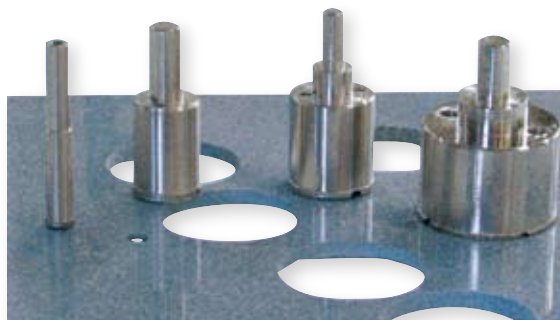

CORONAS CORTE EN SECO



Corona en seco				
Ref.	Profundidad máxima	∅		€
349137	35 mm	20 mm	1	27,80
349138	35 mm	27 mm	1	34,00
349139	35 mm	35 mm	1	45,30
349140	35 mm	50 mm	1	67,00
349141	35 mm	60 mm	1	72,10
349142	35 mm	65 mm	1	80,30
349143	35 mm	67 mm	1	83,45
349144	35 mm	75 mm	1	91,65
518726	30 mm	100 mm	1	112,25
518727	30 mm	125 mm	1	151,00
349092	Adap. M14 a ∅ 10 mm.		1	7,60



349092

Adaptador de coronas para taladro

PINZAS Y TENAZAS



Ref.	Descripción	máx		€
725	Pinza de ceramista	200 mm	6	14,50
115 119	Pinza para monocido y revestimiento vítreo con brazos recubiertos y curvados	200 mm	6	14,85
124	Pinza curvada con resorte de retroceso y brazos recubiertos	190 mm	6	9,40
123	Tenaza con resorte de retroceso y brazos recubiertos	220 mm	6	10,60
784	Pinza de cortar con rodil de carburo de tungsteno		6	9,90
216VB	Pinza de cortar perfil PVC, indicador graduable de ángulo		1	20,50

TRAZADORES - UTILES DE SERRAR - RECORTAR Y PULIR



Ref.	Descripción	máx		€
349300	Rascador de juntas		6	4,85
349306	Hoja de recambio (blister 3 unidades)		6	6,05
113	Trazador de tungsteno con bola de protección. Doble punta. Doble uso.	180 mm	6	4,60
143	Trazador-cortador a mordaza	200 mm	6	8,70

955	Sierra berbiquí con broca e hilo de carburo de tungsteno	S. 300 mm Berb. Ø 10	3	9,80
863	Hilo cortador de carburo de tungsteno	305 mm	6	5,45
862	Hoja de serrar de carburo de tungsteno	305 mm	6	6,70

137	Piedra pulidora rectangular	Grano medio	6	6,85
-----	-----------------------------	-------------	---	------



519/2	Lima abrasiva de tungsteno doble cara con mango recubierto	325 mm	6	12,15
349044	Lima media caña carburo tungsteno	325 mm	6	10,25

DIAFER-MAT

EL TODO TERRENO DEFINITIVO

Corte más rápido,
más limpio y
más económico

CORTA TODO TIPO DE MATERIALES

- Tubos, plancha de acero, varilla de acero del hormigón, hierro colado...
- Gres, hormigón, materiales tradicionales...
- Tejas de hormigón, barro cocido, pizarra...

disponible en varios diámetros:

Ø 115 mm Ø 125 mm Ø 150 mm Ø 230 mm Ø 300 mm Ø 350 mm

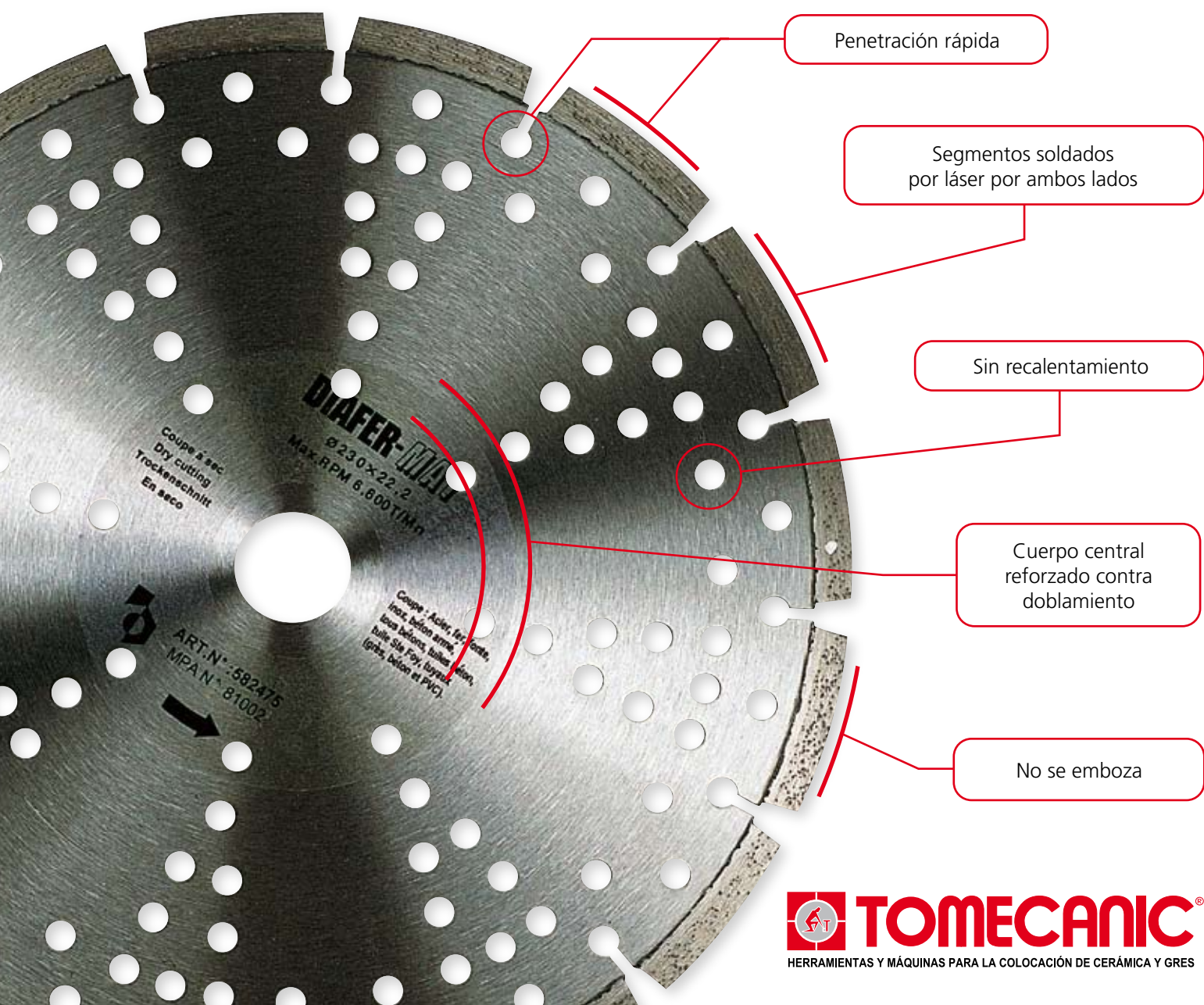

Penetración rápida

Segmentos soldados por láser por ambos lados

Sin recalentamiento

Cuerpo central reforzado contra doblamiento

No se emboza

DISCOS DE ALTAS PRESTACIONES

DIAFER-MAT

TODO TERRENO



Corte en seco y húmedo

Indicado para: Todo tipo de materiales de la obra - Corte fino y preciso

Corta tubos, plancha de acero, varilla de acero, hierro colado, gres, hormigón, tejas de hormigón, barro cocido, pizarra, piedra, etc.

Calidad: Buen rendimiento

Ref.	(mm)	(mm)	(mm)	€
582471	115 mm	22,2 mm	8	63,00
582472	125 mm	22,2 mm	8	79,00
582473	150 mm	22,2 mm	8	101,00
582475	230 mm	22,2 mm	8	133,00
582476	230 mm	22,2 mm	12	147,00
582479	300 mm	22,2 mm	8	240,00
582480	300 mm	25,4 mm	8	240,00
582486	350 mm	22,2 mm	8	273,00
582487	350 mm	25,4 mm	8	273,00

GRIND CUT



Ref.	(mm)	(mm)	(mm)	€
560640	105 mm	22,2 mm	5	39,00

Con 12 refuerzos laterales diamantados

Modalidad de uso: Corte en seco y húmedo

Muy apropiado para: Rebajar, ajustar, biselar todo tipo de cerámica, mármol, piedra, granito y pizarra, etc.

Calidad: Superior

CRODIAM

ALTO RENDIMIENTO



Corte en seco y húmedo

Indicado para: Cortar todos los productos de hormigón (excepto hormigón fresco), bloque de hormigón, tejas, rocas, etc.

Calidad: Corte rápido - Alto rendimiento.

Ref.	(mm)	(mm)	(mm)	€
581091	230 mm	22,2 mm	10	141,00
582607	300 mm	22,2 mm	10	263,00
582608	300 mm	25,4 mm	10	263,00
582612	350 mm	22,2 mm	10	298,00
582613	350 mm	25,4 mm	10	298,00

CERACUT

CERÁMICA MUY DURA



Corte en seco y húmedo

Indicado para: Cerámica y baldosas muy duras.

Calidad: Larga duración.

Ref.	(mm)	(mm)	(mm)	€
560625	115 mm	22,2 mm	5	31,00
560630	125 mm	22,2 mm	5	35,00

EXTREMM

LARGA DURACION



Corte en seco y húmedo

Indicado para: Corte y acabado con precisión. Para cortar en seco cerámica, porcelánico, granito y otras baldosas muy duras
Rendimiento y duración extremos.

Ref.	(mm)	(mm)	(mm)	€
580340	115 mm	22,2 mm	6	48,00
580345	125 mm	22,2 mm	6	58,00

GRES Y CERAMICA

DIAM CUT STANDARD



CERAMICA

**Corte húmedo**

Indicado para: Todo tipo de cerámica.

Calidad: Buena.



Ref.				€
811	125 mm	25,4 mm	5	29,00
816	150 mm	25,4 mm	5	33,00
822	180 mm	30 mm	5	37,00
889	200 mm	30 mm	5	48,00
834	230 mm	25,4 mm	5	53,00
887	250 mm	25,4 mm	5	122,00
560602	300 mm	25,4 mm	5	134,00
583140	350 mm	25,4 mm	5	153,00

DIAM CUT DX

CERAMICA

**Corte húmedo**

Indicado para: Todo tipo de cerámica.

Calidad: Superior.



Ref.				€
560605	125 mm	25,4 mm	6	31,00
560606	150 mm	25,4 mm	6	43,00
872	180 mm	30 mm	6	49,00
827	200 mm	30 mm	6	56,00
833	230 mm	25,4 mm	6	66,00
886	250 mm	25,4 mm	7	127,00
893	300 mm	25,4 mm	8	139,00

GRES PORCELANICO CORTE HUMEDO

**Corte húmedo**

Indicado para: Gres porcelánico

Calidad: Larga duración.

Ref.				€
5830850	300 mm	30/25,4 mm	5	208,00
5830900	350 mm	30/25,4 mm	5	260,00



GRES PORCELANICO SEC

EN SECO

**Corte en seco y húmedo**

Indicado para: Gres porcelánico

Calidad: Larga duración.

Ref.				€
5830650	180 mm	22,2 mm	5	67,00
5830700	200 mm	25,4/22,2 mm	5	90,00
5830750	230 mm	25,4/22,2 mm	5	106,00



GRES PORCELANICO SEC

EN SECO

**Corte en seco y húmedo**

Indicado para: Gres porcelánico

Calidad: Larga duración.

Ref.				€
580340	115 mm	22,2 mm	5	48,00
580345	125 mm	22,2 mm	5	58,00

MATERIALES CONSTRUCCION (EXCEPTO ABRASIVOS)

BASIC SEGMENTADO GENERAL OBRA

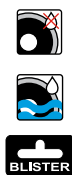

Corte en seco y húmedo
Indicado para: Para todos los materiales de la obra - Disco económico
Calidad: Standard

Ref.				€
568405	115 mm	22,2 mm	6	14,00
568410	125 mm	22,2 mm	6	15,00
568415	230 mm	22,2 mm	6	38,00

BASIC TURBO GENERAL OBRA



Corte en seco y húmedo
Indicado para: Para todos los materiales de la obra - Disco económico
Calidad: Standard-Plus

Ref.				€
568455	115 mm	22,2 mm	6	15,00
568460	125 mm	22,2 mm	6	17,00
568465	230 mm	22,2 mm	6	39,00

SE KF - SANKYO GENERAL OBRA



Corte en seco y húmedo
Indicado para: Para todos los materiales de la obra - Universal segmentado
Calidad: Buen rendimiento

Ref.				€
580110	115 mm	22,2 mm	6	23,00
580115	125 mm	22,2 mm	6	25,00
580120	150 mm	22,2 mm	6	48,00
580125	180 mm	22,2 mm	6	51,00
580811	230 mm	22,2 mm	10	61,00
580135	230 mm	22,2 mm	6	54,00
560610	300 mm	25,4 mm	6	117,00
897	350 mm	25,4 mm	6	128,00

LCA LASER SUPER TRABAJOS INTENSIVOS



Corte en seco y húmedo
Indicado para: Para trabajo intensivo sobre todos los productos de hormigón (excepto hormigón fresco), terrazo, etc.

Ref.				€
580200	115 mm	22,2 mm	6	37,00
580205	125 mm	22,2 mm	6	40,00
580210	150 mm	22,2 mm	6	50,00
580225	230 mm	22,2 mm	6	74,00

TURBINO RK GENERAL OBRA



Corte en seco y húmedo
Indicado para: Para todos los materiales de la obra - Corte fino y preciso
Calidad: Buen rendimiento

Ref.				€
580150	115 mm	22,2 mm	6	22,00
580155	125 mm	22,2 mm	6	25,00
580160	150 mm	22,2 mm	6	48,00
580165	180 mm	22,2 mm	6	55,00
580170	200 mm	22,2 mm	6	56,00
829	200 mm	30 mm	6	58,00
580175	230 mm	22,2 mm	6	57,00
560041	230 mm	22,2 mm	6	67,00
835	230	30 mm	6	69,00
866	300 mm	30 mm	6	155,00

BENEDUR SDE LARGA DURACION



Corte en seco y húmedo
Indicado para: Granito, terrazo, tejas de todo tipo, etc.
Calidad: Penetración elevada - Larga duración

Ref.				€
580035	115 mm	22,2 mm	6	47,00
580040	125 mm	22,2 mm	6	54,00
580045	150 mm	22,2 mm	6	74,00
580050	180 mm	22,2 mm	6	86,00
580060	230 mm	22,2 mm	6	119,00
580085	300 mm	25,4 mm	6	168,00

MATERIALES CONSTRUCCION (EXCEPTO ABRASIVOS)



SPRINTER H8

SUPER RAPIDO

**Corte en seco y húmedo**

Indicado para: Para cortar más rápidamente todo tipo de material de obra.

Calidad: Corte muy rápido - Super ventilado y dentado **con refuerzos**

Ref.				€
580037	115 mm	22,2 mm	8	71,00
580042	125 mm	22,2 mm	8	74,00
580047	150 mm	22,2 mm	8	107,00
580051	180 mm	22,2 mm	8	118,00
580066	230 mm	22,2 mm	10	157,00
580081	300 mm	22,2 mm	10	245,00
580086	300 mm	25,4 mm	10	245,00



CALAV ER

ESPECIAL COLOCADOR

**Corte húmedo**

Indicado para: Para cortar todo tipo de material de la obra (granito, ladrillo, mármol, terrazo, teja...)

Calidad: Buen rendimiento - Especial colocador.

Ref.				€
582070	250 mm	25,4 mm	10	153,00
582075	300 mm	25,4 mm	10	173,00
582085	350 mm	25,4 mm	10	211,00
582095	400 mm	25,4 mm	10	315,00
582100	450 mm	25,4 mm	10	371,00
582105	500 mm	25,4 mm	10	422,00

CORTE DE MARMOL

ELECTRODEPOSITADO MARMOL EN SECO

**Corte en seco y húmedo**

Indicado para: Cortar mármol en seco.

Con 3 o 4 refuerzos laterales según tamaño del disco.

Ref.				€
585010	115 mm	22,2 mm	5	85,00
585015	125 mm	22,2 mm	5	91,00
585025	180 mm	22,2 mm	5	138,00
585030	200 mm	22,2 mm	5	146,00
585035	230 mm	25,4 mm	5	162,00

MARMOL MC

CORTE HUMEDO

**Corte húmedo**

Indicado para: Especialmente adaptado para cortar con agua el mármol.

Ref.				€
582250	250 mm	25,4/50 mm	6	181,00
582255	300 mm	25,4/50 mm	6	214,00
582260	350 mm	25,4/50 mm	6	260,00
582265	400 mm	25,4/50 mm	6	319,00
582270	450 mm	25,4/50 mm	6	428,00
582275	500 mm	25,4/50 mm	6	450,00
582280	600 mm	100/60/50 mm	6	605,00
582290	700 mm	100/60/50 mm	6	815,00

CORTE DE TODOS LOS MATERIALES ABRASIVOS



LW ALQ LASER ABRASIVOS EN SECO



Corte en seco y húmedo

Indicado para: Asfalto, hormigón fresco, refractarios, piedras abrasivas, ladrillos cara vista, arenisca, autoblocantes.

Calidad: Larga duración

Ref.				€
580240	115 mm	22,2 mm	6	66,00
580250	125 mm	22,2 mm	6	70,00
580260	150 mm	22,2 mm	6	90,00
580265	180 mm	22,2 mm	6	112,00
580270	200 mm	22,2 mm	6	119,00
580275	230 mm	22,2 mm	6	128,00
580480	300 mm	22,2 mm	7	213,00
580485	300 mm	25,4 mm	7	213,00
580495	350 mm	22,2 mm	7	267,00
580500	350 mm	25,4 mm	7	267,00

MACO ABRASIVOS CORTE HUMEDO



Corte húmedo

Indicado para: Tejas de hormigón, auto-blocantes refractarios, ladrillos cara vista, arenisca

Ref.				€
582110	300 mm	25,4 mm	6	316,00
582115	350 mm	25,4 mm	6	355,00
582120	400 mm	25,4 mm	6	395,00
582125	500 mm	25,4 mm	6	633,00
582131	625 mm	25,4 mm / 60 mm	6	917,00

CORTE DE PIEDRA ABRASIVA

PR - PIEDRA ABRASIVA



Corte húmedo

Indicado para: Particularmente apropiado para el corte de piedra abrasiva.

Ref.				€
582160	300 mm	25,4/50 mm	6	315,00
582165	350 mm	25,4/50 mm	6	389,00
582170	400 mm	25,4/50 mm	6	432,00
582175	450 mm	25,4/50 mm	6	496,00
582180	500 mm	25,4/50 mm	6	618,00
582185	625 mm	100/60/50 mm	6	949,00
582190	725 mm	100/60/50 mm	6	1.274,00

GIT - GRANITO



Corte húmedo

Indicado para: Especialmente adaptado para cortar el granito.

Calidad: Disco muy resistente

Ref.				€
582300	300 mm	25,4/50 mm	10	275,00
582305	350 mm	25,4/50 mm	10	306,00
582310	400 mm	25,4/50 mm	10	371,00
582315	450 mm	25,4/50 mm	10	489,00
582320	500 mm	25,4/50 mm	10	575,00
582325	600 mm	100/60/50 mm	10	765,00



CORTE DE HORMIGON / ASFALTO

LASER BF

HORMIGON FRESCO

**Corte húmedo**

Indicado para: corte de hormigón fresco (-21 días), conglomerado silíceo, chapas anti-desgaste

Ref.				€
582230	300 mm	25,4 mm	6	230,00
582235	350 mm	25,4 mm	6	287,00

LASER BVPG

HORMIGON VIEJO

**Corte húmedo**



Indicado para: cortar el hormigón viejo (+21 días) y todo tipo de conglomerados.

Ref.				€
582135	300 mm	25,4 mm	6	234,00
582140	350 mm	25,4 mm	6	279,00
582145	400 mm	25,4 mm	6	362,00
582150	450 mm	25,4 mm	6	471,00
582155	500 mm	25,4 mm	6	626,00

LASER BFA SUPER HORMIGON FRESCO

**Corte en seco y húmedo**



Indicado para: cortar el asfalto en seco o con agua

Ref.				€
580010	300 mm	25,4 mm	8	246,00
580015	350 mm	25,4 mm	8	329,00
580020	400 mm	25,4 mm	8	513,00
580025	450 mm	25,4 mm	8	639,00

LASER BFA ASFALTO CORTE HUMEDO

**Corte húmedo**

Indicado para: cortar con agua el asfalto, silicio calcáreo y abrasivo

Ref.				€
582210	350 mm	25,4 mm	7	297,00
582215	400 mm	25,4 mm	7	378,00
582220	450 mm	25,4 mm	7	460,00
582225	500 mm	25,4 mm	7	605,00

PLATOS DIAMANTADOS CÓNCAVOS

PLATOS DIAMANTADOS



Corte en seco

Calidad: Superior

Ref.	(mm)	(mm)		€
584300	110 mm	22,2 mm	1	110,00
584400	125 mm	22,2 mm	1	140,00
584405	180 mm	22,2 mm	1	260,00

DISCOS ABRASIVOS SPEEDFLEX

CORTE ACERO



Corte en seco

Calidad: Superior

Ref.	(mm)	(mm)	(mm)		€
568004	115 mm	22,2 mm	3,2	25	1,10
568005	125 mm	22,2 mm	3,2	25	1,15
568006	230 mm	22,2 mm	3,2	25	2,35
568008	300 mm	22,2 mm	3,5	25	6,85

DESBASTE ACERO

Ref.	(mm)	(mm)	(mm)		€
568017	115 mm	22,2 mm	6,4	25	1,65
568018	125 mm	22,2 mm	6,4	25	1,85
568019	230 mm	22,2 mm	6,4	25	4,75

CORTE MATERIAL CONSTRUCCION



Corte en seco

Calidad: Superior

Ref.	(mm)	(mm)	(mm)		€
568014	115 mm	22,2 mm	3,2	25	1,15
568015	125 mm	22,2 mm	3,2	25	1,30
568016	230 mm	22,2 mm	3,2	25	2,60
568081	300 mm	22,2 mm	3,5	25	5,85

DESBASTE HORMIGON



Trabajo en seco

Indicado para: Hormigón.

Calidad: Superior

Ref.	(mm)	(mm)	Grano		€
568115	115 mm	22,2 mm	36	25	2,50
568125	125 mm	22,2 mm	36	25	2,65
568180	180 mm	22,2 mm	36	25	2,80

MAQUINARIA para CONSTRUCCIÓN



MAQUINA ELECTRICA PARA LLENADO DE JUNTAS Y LIMPIEZA



8874



503055B

JUNTASOL

Ref.	Modelo	€
8874	JUNTASOL	1.025,00

- Máquina eléctrica con cepillo incluido Ref. 8854
- Motor monofásico: 220 V Potencia HP 0'75
· 2 velocidades (66 R.P.M. - 132 R.P.M.)
- Depósito 10 litros (Agua/Ácidos) incluido.
- Diámetro del cepillo de nylon: 400 mm · Peso de la máquina 25 Kg.

JUNTASOL SUPER 50

Ref.	Modelo	€
503055B	JUNTASOL SUPER 50	1.480,00

- Máquina eléctrica con cepillo incluido reg. 590101B
- Motor monofásico: 220 V Potencia 1,5 CV / 2 velocidades (55 R.P.M. - 110 R.P.M.)
- Depósito 10 litros (Agua/Ácidos) incluido. · Peso de la máquina: 42 Kg.

Ref.	Accesorios JUNTASOL 8874	€
8853	Acoplador para rejuntar Ø 380 mm Equipado de 5 láminas de vulkolán reforzado	95,00
8854	Cepillo Ø 384 mm. Púas de polipropileno	87,00
8876	Acoplador adhesivo para disco TAF	94,00
8877	Acoplador - cepillo metálico para limpiar	102,00
8878	Acoplador - plancha para alisar	111,00

Ref.	Accesorios JUNTASOL SUPER 50	€
590095B	Acoplador para rejuntar Ø 560 mm Equipado de láminas de vulkolán reforzado	133,00
590096B	Acoplador adhesivo para disco TAF Ø 460 mm.	125,00
590101B	Cepillo duro Ø 500 mm blanco	102,00
590102B	Cepillo blando Ø 500 mm amarillo	122,00

SEGMENTOS DIAMANTADOS

PARA PULIDO DE PAVIMENTOS

Ref.	Características	€
024060	Grano 60 verde. Muy abrasivo	13,45
024120	Grano 120 negro. Abrasivo	13,45
024400	Grano 400 marrón. Suave	13,45
024800	Grano 800 blanco. Muy suave	13,45



DISCOS TAF FIBRAS DE NYLON O POLIESTER

PARA MÁQUINAS ELÉCTRICAS DE LIMPIAR SUELOS

Ref.	Accesorios JUNTASOL y SUPER 50	Ø	Icono	€
280511	Disco TAF negro fibra nylon muy abrasivo (cartón 5 unidades)	406	1	47,70
280512	Disco TAF verde fibra nylon abrasiva (cartón 5 unidades)	406	1	47,70
280513	Disco TAF salmón fibra polyester semi-suave (cartón 5 unidades)	406	1	42,95
280514	Disco TAF blanco fibra polyester suave (cartón 5 unidades)	406	1	45,40
214170	Disco TAF negro fibra nylon muy abrasivo (cartón 5 unidades)	505	1	75,60
214155	Disco TAF verde fibra nylon abrasivo (cartón 5 unidades)	505	1	68,85
214165	Disco TAF rojo fibra nylon suave (cartón 5 unidades)	505	1	66,90
214160	Disco TAF blanco fibra nylon muy suave (cartón 5 unidades)	505	1	66,90



Fijación a velcro con platos adhesivos.

Ref. 8876 o 590096

PULIDORAS DE SUELO BENEPULE



504105



504110

Ref.	Modelo	Motor	∅ plato	kg	€
504105	BENEPULE 250	220V-50Hz / 3CV / 1.500 r.p.m.	250 mm	70	1.830,00
504110	BENEPULE 300	380V-50Hz / 4CV / 1.500 r.p.m.	300 mm	84	2.050,00

Dotadas de virolas de protección y muelle amortiguador

BLOQUES DIAMANTADOS PARA PULIDORA

Ref.	Grano	€
584265	Bloc terrazo "Blanco"	195,00
584270	Bloc hormigón fresco "Verde"	233,00
584275	Bloc hormigón viejo "Rojo"	224,00
584280	Bloc Granito "Azul"	192,00
584285	Bloc mármol "Amarillo"	152,00

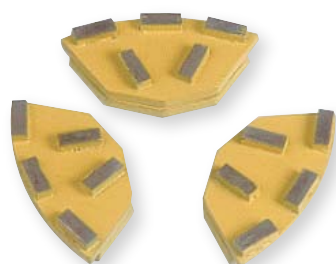

BLOQUES ABRASIVOS PARA PULIDORA

Ref.	Grano	Aplicación	€
588215	16	Desbaste	2,45
588220	36	Mediano	2,45
588225	60	Mediano	2,45
588230	120	Suave	2,45
588335	220	Antes Pulido	2,45
588340	320	Antes Pulido	2,65
588345	400	Antes Pulido	2,75
588350	5 Extra	Pulido	11,70

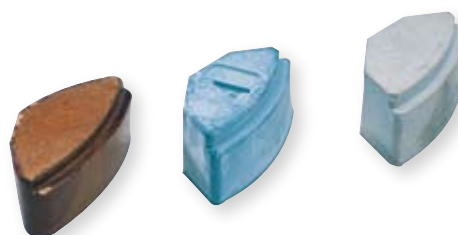

LIMPIA JUNTAS



Ref.	Modelo	€
M100E	LIMPIA JUNTAS	1.230,00

- Conexión a la red eléctrica 230 V.
- Equipada con transformador y banda esponja - Tensión: 36 V - Potencia: 180 W
- Revolución con reducción 80 R.P.M.
- Peso de la máquina: 32 Kg.

Ref.	Banda esponja para limpiar juntas	€
2737	Banda esponja para Ref. M100S y Ref. M100E	129,00
0341	Banda esponja para Ref. M100S y Ref. M100E	85,00

VIBRADORES ELECTRICOS



MINI VIBRADOR

Ref.	Modelo	€
820	MINI VIBRADOR	508,00

- Vibrador eléctrico manual
- Motor eléctrico: 42 V / 75 W
- Transformador: 220 V / 48 V, 1 Amperio
- Variador de velocidad - potenciómetro
- Peso: 9 Kg.



VIBRO 5

Ref.	Modelo	€
850	VIBRADOR	944,00

- Vibrador eléctrico de 50 rodillos
- Motor eléctrico: 42 V / 250 W
- Transformador: 220 V / 42 V, 2 Amperios
- Variador de velocidad - potenciómetro
- Peso: 43 Kg.
- Dimensiones: 55 x 49 cm



VIBRO 10

Ref.	Modelo	€
900	VIBRO 10	1.230,00

- Vibrador eléctrico de 10 rodillos contínuos
- Motor eléctrico: 36 V / 200 W
- Transformador: 220 V / 36 V, 7 Amperios
- Variador de velocidad
- Peso: 50 Kg.
- Dimensiones: 51 x 46 cm

REGLAS VIBRANTES BENEREGLE



Ref.	Descripción	€
590154	Regla aluminio 2 metros	122,00
590169	Regla aluminio 2,5 metros	153,00
590155	Regla aluminio 3 metros	182,00
590170	Bloc motor Honda 1,2 CV + pertiga	826,00



- Regla vibrante de gran velocidad
- Motor gasolina 4T. 1,2 CV
- Vibración de alta frecuencia

EQUIPO PARA VIBRACION DEL HORMIGON



Ref.	Modelo	Motor	€
797555H	MOTOR VIBRADOR HORMIGON	115 / 120 V - 60 Hz	263,00
797666H	MOTOR VIBRADOR HORMIGON	220/230 V - 50 Hz	263,00

- Bloque motor 2.000 Watts - 220 V / 50 Hz
- Vibración alta frecuencia 16.000 r.p.m. en vacío - 9.000 r.p.m. en carga
- Peso: 6 Kg.

FLEXIBLES CON AGUJA

Ref.	Modelo	Longitud	€
797035H	Flexible con aguja Ø 35	4 m	256,00
797042H	Flexible con aguja Ø 42	4 m	263,00
797050H	Flexible con aguja Ø 50	4 m	273,00

CORTADORAS DE SUELO BENESOL



Ref.	Modelo	Motor	Profundidad de corte	Ø Disco	€
507045	BENESOL 350	Gasolina HONDA 5,5 CV	110 mm	350 mm	2,265,00
507070	BENESOL 450	Gasolina HONDA 13 CV	170 mm	400-450 mm	2,925,00

- Para hormigón, asfalto, en seco o con agua
- Depósito de agua: 25 litros. - Peso: 115 Kg.

ROZADORA ELECTRICA BI DIAM



Ref.	Modelo	€
T00195	ROZADORA BI DIAM Ø 180	845,00

- MOTOR 220 V - 50 HZ - 1.800 W
- 2 discos Ø 180 mm. **No incluido**
- Máquina suministrada con maletín metálico, piedra afiladora y cincel de vaciado de las rozas.
- Corte: profundidad 60 mm. / ancho de 8 a 50 mm.
- Peso: 14 Kg. con maleta

Ref.	Modelo	€
580265	Disco laser Ø 180 materiales abrasivos	112,00
580165	Disco laser Ø 180 general obra	55,00

Ref.	Modelo	€
504030	ASPIRADOR ASPIDIAM	390,00

- Aspirador de polvo y agua
- Depresión m.c.a.: 2.200 - Caudal: 170 m³/h.
- Motor eléctrico: 230 V -50 Hz. 1.200 W
- Capacidad; 25 litros. Peso: 10 Kg.



PERFORADORAS BENEFOR



Ref.	Modelo	€
508210	KIT BENEFOR 120/150 mm con agua	1.750,00

CARACTERISTICAS:

- Motor eléctrico: 1.800 W - 230 V
- 2 velocidades:

Velocidad	1	2	
r.p.m.	600	2.200	
Ø máximo	120 mm	60 mm	Hormigón
Ø máximo	150 mm	100 mm	Piedra

- Con sistema de seguridad PRCD.
- Columna de aluminio inclinable de 40 x 50 x 700 mm.
- Depósito 8 litros a presión o conexión a la red de agua.
- **Con maleta PVC** y empuñadura.
- Peso: 15 Kg · Salida eje 1/2 "



Ref.	Modelo	€
508230	KIT BENEFOR 200/250 mm con agua	3.560,00

CARACTERISTICAS:

- Motor eléctrico: 2.600 W - 230 V
- 3 velocidades:

Velocidad	1	2	3	
r.p.m.	400	800	1.200	
Ø máximo	220 mm	100 mm	50 mm	Hormigón
Ø máximo	250 mm	150 mm	100 mm	Piedra

- Con sistema de seguridad PRCD.
- Columna de aluminio inclinable de 70 x 70 x 1.000 mm.
- Sistema de refrigeración incluido.
- Con rueda de transporte.
- Peso: 15 Kg · Salida eje 1/2 "

CORONAS PARA PERFORADORAS

	ADAPTADORES	€
590087	M 16 X 1/2 G	19,00
590086	M 16 X 1"1/4 UNC	37,00
590088	M 30 X 1/2 G	20,00
590085	M 30 X 1"1/4 UNC	31,00

- Longitud = 42 cm

Ref.	Ø Ext.	Segmentos	€
586180	40	4	151,00
586200	50	5	177,00
586220	60	5	185,00
586225	65	6	204,00
586230	70	6	212,00

Ref.	Ø Ext.	Segmentos	€
586240	80	7	230,00
586250	90	7	237,00
586255	95	8	259,00
586260	100	8	267,00
586270	110	9	302,00
586280	120	10	339,00
586300	130	11	362,00
586310	140	11	396,00
586320	150	12	465,00
586330	160	13	510,00
586340	170	13	528,00
586350	180	14	556,00
586355	185	14	578,00
586360	200	15	596,00



FRATASADORAS BENELISS

Ref.	Modelo	Motor	kg	€
502065	FRATASADORA Ø 900mm	Gasolina HONDA 5,5 CV	90	2.890,00
502080	FRATASADORA Ø 1.200 mm	Gasolina HONDA 9 CV	110	3.980,00



PALAS DE RECAMBIO

Ref.	BENELIS '900	€
590146	Pala de desbaste	101,00
590148	Pala mixta	87,00
590149	Pala acabado	79,00

Ref.	BENELIS '1.200	€
590147	Pala de desbaste	110,00
590150	Pala mixta	102,00
590151	Pala acabado	89,00

- Reglaje de inclinación de palas mecánico
- Se suministra con juego de palas mixtas
- Doble aislamiento eléctrico
- Tubo gancho para un transporte cómodo y fácil
- Parada de seguridad
- Brazo plegable y regulable

MEZCLADOR ELECTRICO

- Cubeta PVC 60 litros
- Motor monofásico 230 V / 50-60 Hz - 2.800 r.p.m. - 1.200 w
- Velocidad reductor: 55 r.p.m. - Peso: 24 Kgs.
- Mezclador universal: morteros, pinturas, colas, barnices, resinas epoxy.

Ref.	Modelo	€
503090B	BENECOL 60	645,00

590735	Cubeta de goma	25,70
--------	----------------	-------



MEZCLADOR ELECTRONICO CON MALETA

Máquina electrónica de gran potencia para la mezcla de todo tipo de materiales como cemento cola, pinturas, cementos con resinas, etc.



Ref.	Modelo	€
503165	Mezclador electrónico	270,00
523165	Mezclador electrónico con maleta	296,00

CARACTERISTICAS:

- Motor: 1.600 W - 0 a 450 r.p.m.
- 2 velocidades mediante engranajes:
Velocidad 1: 150 - 400 r.p.m.
Velocidad 2: 250 - 700 r.p.m.
- Variador electrónico de velocidad.
- Incluye varilla de mezcla \varnothing de 140 mm.
- Anclaje para varilla con rosca M14.
- Gran capacidad de mezcla.
- Peso: 6 Kg.

Ref.	Modelo	€
523110	Mezclador electrónico con maleta	257,00
100111	Porta broca \varnothing 13 mm con llave	24,00
100112	Recambio espiga	13,05

CARACTERISTICAS:

- Motor: 1.100 W - 0 a 450 r.p.m.
- Anclaje para varilla M14.
- Batidor de 120 mm. de diámetro (opcional).
- Control electrónico de revoluciones.
- Maletín para transporte.

Ref.	Modelo	⊠	€
503100	Batidor \varnothing 120 mm M14	60 cm	22,15
503102	Batidor \varnothing 140 mm M14	60 cm	27,40
503101	Batidor \varnothing 160 mm M14	60 cm	32,80

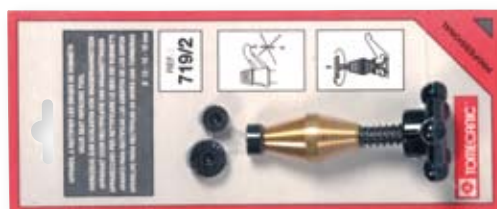

Ref.	Descripción		€
718	Abocinador de 10-12-14-16 mm	6	21,60
760	Abocinador de 10-12-14-16-18-20-22 mm	3	44,35
711	Abocardador de 10-12-14-16 mm	6	5,65

430300	Tenaza curvatubos 8 x 10 mm	3	17,95
430301	Tenaza curvatubos 10 x 12 mm	3	18,50
430302	Tenaza curvatubos 12 x 14 mm	3	23,50
430303	Tenaza curvatubos 14 x 16 mm	3	24,50

726/10	Muelle curvatubos 8 x 10 mm	6	5,10
726/12	Muelle curvatubos 10 x 12 mm	6	5,45
726/14	Muelle curvatubos 12 x 14 mm	6	5,95
726/16	Muelle curvatubos 14 x 16 mm	6	6,95

707	Cortatubos para cobre de 3 a 30 mm	6	7,95
708	Mini-cortatubos para cobre de 3 a 22 mm	6	5,75
765	Cortatubos telescópico de 3 a 32 mm	6	14,90
768	Cortatubos para hierro de 1/8" a 1 1/4"	1	65,85

715	Rodel recambio para Ref. 707-708	6	3,95
770	Rodel recambio para Ref. 765	6	2,85

773	Tenaza de canal 240 mm	6	13,85
-----	------------------------	---	-------

702/4	Llave de cadena reversible	3	42,45
703/32	Llave extensible lavabo 32 mm	3	19,70
703/48	Llave extensible lavabo 48 mm	3	24,65
721/32	Llave tuerca lavabo 32 mm	3	11,55
721/48	Llave tuerca lavabo 48 mm	3	14,25

704/10	Llave Stillson 10"	2	17,75
704/14	Llave Stillson 14"	2	23,10
704/18	Llave Stillson 18"	2	32,70
704/24	Llave Stillson 24"	2	53,30

430100	Llave tipo sueca 1" 315 mm	2	13,40
430101	Llave tipo sueca 1 1/2" 430 mm	2	16,50
430102	Llave tipo sueca 2" 560 mm	2	22,80

719/1	Rectificador asiento grifería (10-12-13-14-15-16 mm)	3	13,10
719/2	Rectificador asiento grifería (13-15-18 mm)	2	11,20



Ref.	Descripción		€
430005	Brazo monobloc con cabeza para terrajas	1	31,05
430006	Terraja 3/8" (Para tubo Ø 12 x 17 mm)	1	14,70
430007	Terraja 1/2" (Para tubo Ø 15 x 21 mm)	1	15,25
430008	Terraja 3/4" (Para tubo Ø 20 x 27 mm)	1	15,70
430009	Terraja 1" (Para tubo Ø 26 x 34 mm)	1	16,55
430010	Terraja 1 1/4" (Para tubo Ø 33 x 42 mm)	1	16,95
430041	Estuche terrajas con brazo monobloc y 5 terrajas intercambiables: 3,8", 1/2", 3/4", 1", 1 1/4"	1	92,35

DESATASCADORES



712	Desatascador con escobilla nylon Longitud 1,5 m.	3	9,45
-----	---	---	------



430210	Desatascador de tambor. Longitud 4,6 m. Escobilla y espiral 12 mm.	1	13,15
--------	---	---	-------

430221	Desatascador de manivela Longitud 6 m. Escobilla y espiral 20 mm.	1	14,45
--------	--	---	-------



776	Desatascador con escobillas 20 - 30 mm y manivela Longitud 3 m.	3	12,40
-----	--	---	-------



778	Desatascador con espiral, escobillas 30 mm y manivela. Longitud 1,5 m.	3	19,65
-----	---	---	-------



780	Desatascador con espiral, escobillas 30 mm. y manivela. Longitud 2 m.	3	27,40
-----	--	---	-------



788	Desatascador 10 mm. con espiral y escobilla 30 mm. Longitud 3 m.	3	28,20
-----	---	---	-------



790	Desatascador 12 mm. con espiral y escobillas 20-30-50 mm. Longitud 4m.	3	40,80
-----	---	---	-------



782	Desatascador de presión con 2 ventosas	3	20,65
-----	--	---	-------

783	Escobilla metálica para Ref. 776-778-780-788-790	3	6,95
-----	--	---	------



DECAPAR · LIMPIAR · MANTENER

Ref.	Descripción		€
DA 40/1L	Decapante - Superficie / Litro: 15 a 20 m ²	6	4,60
DA 40/5L	Acido neutro para salitre, manchas de cemento y otras	4	15,50
NT 25	Limpiador - Superficie/Litro: 10 a 20 m ² Solución de base alcalina para manchas de grasa y cera	6	6,90
SV 30	Disolvente - Superficie / Litro: 20 m ² Solución a base de disolvente para barnices y viejas ceras	6	10,65

PROTECCION

Ref.	Descripción		€
PRO 10/1L	Protector - Superficie / Litro: 15 a 20 m ²	6	6,50
PRO 10/5L	Emulsión hidrófuga de protección anterior al llenado de juntas	4	26,95
PRO 20/1L	Protector - Sup./Litro: 15 a 30 m ² Protector antimanchas en gres porcelánico pulido. Aplicado antes de rellenar las juntas con morteros coloreados, limita la absorción de los pigmentos y facilita la limpieza posterior.	6	14,55
PRO 20/5L		4	67,25

TRATAR · ENCERAR

Ref.	Descripción		€
N 50/1L	Cirwax natural - Superficie / Litro: 10 m ²	6	8,55
N 50/5L	Emulsión a base de cera vegetal para tratamiento completo en profundidad	4	37,95
VC 60/1L	Cirwax cuero viejo - Superficie / Litro: 10 m ²	6	8,90
VC 60/5L	Emulsión a base de cera vegeta para tratamiento completo en profundidad.	4	39,30

MANTENER · RENOVAR

Ref.	Descripción		€
PROP' 9	Mantener - Renovar - Lustrar - Superficie / Litro: 10 m ²	6	6,10

IMPERMEABILIZAR

Ref.	Descripción		€
IM 20/1L	Impermeabilizante - Superficie / Litro: 10 a 20 m ²	6	14,85
IM 20/5L	Protección contra proyección de agua y manchas corrientes	4	69,25
IM 28/1L	Impermeabilizante - Superficie / Litro: 10 a 20 m ²	6	20,95
IM 28/5L	Superprotector contra todas las manchas	4	97,45
IM 10/5L	Protector - Superficie / Litro: 7 a 10 m ² Impermeabilizante para todo tipo de piedra	4	61,30

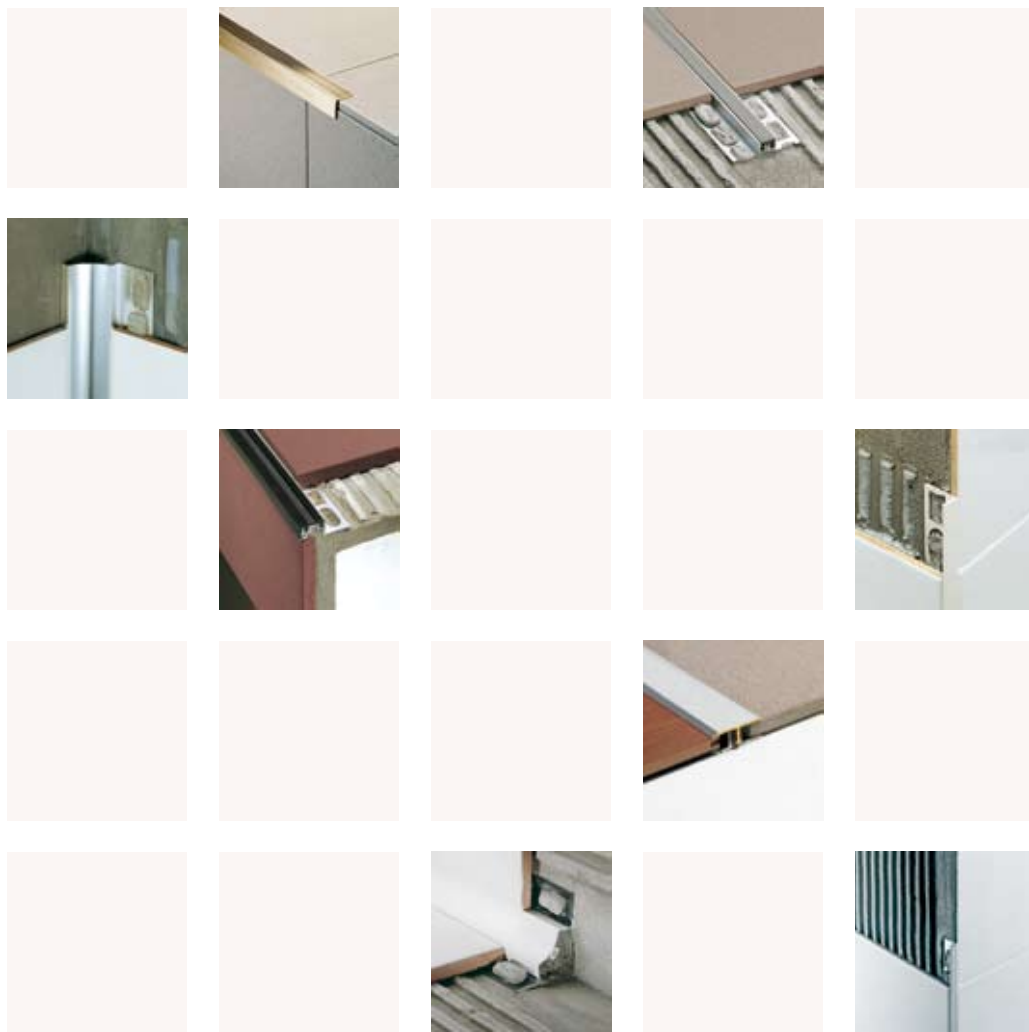

TOMECANIC®



 **TOMECANIC®**
División de Perfiles

TEKNO-TRIM PVC

Serie 877

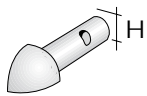

Longitud: 2'70 m.

Color	H 6,5 mm	H 8 mm	H 10 mm	Pack
Blanco	877201	877401	877601	100
Marfil	877210	877410	877610	100
Gris claro	877202	877402	877602	100
Beige	877205	877405	877605	100
Gris oscuro	877203	877403	877603	100
Caramelo	877206	877406	877606	100
Rosa	877204	877404	877604	100
Rojo	877209	877409	877609	100
Marron	877208	877408	877608	100
Azul	877207	877407	877607	100
Amarillo	877211	877411	877611	100
Negro	877212	877412	877612	100
Euros	1,25	1,34	1,39	

Piezas de ángulo
(Blíster de 12 piezas)

H 6,5 mm	H 8 mm	H 10 mm
879401	879501	879601
879410	879510	879610
879402	879502	879602
879405	879505	879605
879403	879503	879603
879406	879506	879606
879404	879504	879604
879409	879509	879609
879408	879508	879608
879407	879507	879607
879411	879511	879611
879412	879512	879612
7,20	7,20	7,20

GAMA STANDARD PVC

Serie 878



Longitud: 2'60 m.

Color	H 10 mm	H 12 mm	Pack
Blanco	878101	878201	100
Marfil	878110	878210	100
Gris claro	878102	878202	100
Beige	878105	878205	100
Gris oscuro	878103	878203	100
Caramelo	878106	878206	100
Rosa	878104	878204	100
Rojo	878109	878209	100
Marrón	878108	878208	100
Azul	878107	878207	100
Amarillo	878111	878211	100
Negro	878112	878212	100
Euros	1,06	1,30	

MARMOL-TRIM PVC

Serie 875

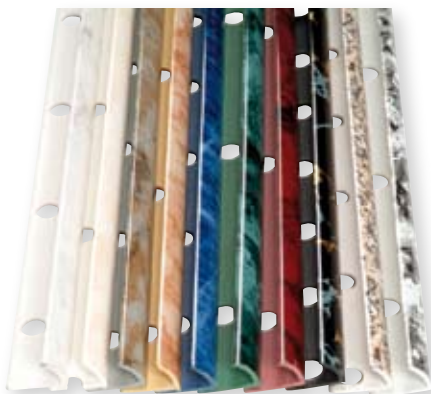

Longitud: 2'60 m.

Color	H 10 mm	Pack
Marmoleado Blanco	875181	100
Marmoleado Crema	875180	100
Marmoleado Gris	875184	100
Marmoleado Marrón	875182	100
Marmoleado Azul	875186	100
Marmoleado Verde	875188	100
Marmoleado Granate	875185	100
Marmoleado Negro	875183	100
Granito Marron	875187	100
Granito Negro	875189	100
Euros	2,52	

Sobre pedido se pueden fabricar los perfiles en altura de 6,5 y 8 mm.

TEKNO-CORNER

Serie 777

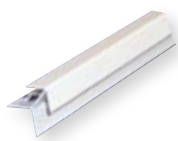

Longitud: 2'70 m.

Color	H (mm)	Pack	Ref.	Euros
Aluminio lacado blanco	12,5 mm	20	777001	11,85
Aluminio plata brillante	12,5 mm	20	777002	11,85
Aluminio oro brillante	12,5 mm	20	777003	11,85

TEKNO-TRIM METAL

Serie 777



Longitud: 2'70 m.

Color	H (mm)	Pack	Ref.	Euros
Latón natural	10	20	777460	38,60
Latón pulido	10	20	777990	50,80
Latón pulido barnizado	8	20	777012	51,80
	10	20	777014	56,80
Latón cromado	10	20	777442	62,90
Acero inoxidable	8	20	777422	25,40
	10	20	777424	26,55
	12,5	20	777426	28,25
	15	20	777428	30,40
Acero inoxidable pulido brillante	10	20	777418	31,95
	12,5	20	777419	33,70
Acero inoxidable cepillado	10 mm	20	777432	29,95
	12,5 mm	20	777433	31,70
	15 mm	20	777434	35,75
Aluminio anodizado natural	8	20	777072	10,65
	10	20	777074	11,75
	12,5	20	777076	13,05
Aluminio anodizado oro	15	20	777078	14,25
	10	20	777044	11,75
	8	20	777312	15,90
Aluminio cromado brillante	10	20	777314	16,65
	12,5	20	777318	18,90
Aluminio oro brillante	8	20	777342	15,90
	10	20	777344	16,65
	12,5	20	777348	18,90
Aluminio lacado blanco	8	20	777102	12,85
	10	20	777104	13,05
	12,5	20	777106	14,60
Aluminio lacado crema	8	20	777132	12,85
	10	20	777134	13,05
Aluminio lacado perla	8	20	777162	12,85
	10	20	777164	13,35
Aluminio lacado beige	8	20	777192	12,85
	10	20	777194	13,35
Aluminio lacado gris	8	20	777222	12,85
	10	20	777224	13,35
Aluminio lacado gris claro	8	20	777252	12,85
	10	20	777254	13,35
Aluminio lacado rojo	8	20	777282	12,85
	10	20	777284	13,35
Aluminio lacado negro	8	20	777402	12,85
	10	20	777404	13,35

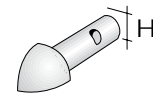

Piezas de ángulo
(Blister 2 piezas)

Ref.	Euros
777694	5,10
777692	5,10
777694	5,10
777487	11,50
777488	11,80
777608	8,15
777610	8,15
777618	8,15
777692	5,10
777694	5,10
777702	5,10
777704	5,10
777622	5,10
777624	5,10
777632	5,10
777634	5,10
777642	5,10
777644	5,10
777652	5,10
777654	5,10
777662	5,10
777664	5,10
777672	5,10
777674	5,10
777682	5,10
777684	5,10
777592	5,10
777594	5,10

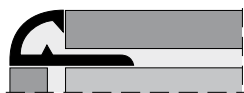

NUEVO
NUEVO

TEKNO-ANGLE METAL

Serie 708

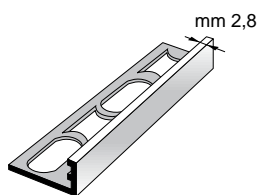

Longitud: 2'70 m.

Descripción	H (mm)	Pack	Ref.	Euros
Latón natural	8	20	708025	19,50
	10	20	708026	20,85
	12,5	20	708027	22,45
	15	20	708028	24,20
Latón cromado brillante	8	20	708115	48,55
	10	20	708116	49,60
	12,5	20	708117	51,35
Aluminio natural	10	20	708161	6,90
	12,5	20	708162	7,25
Aluminio anodizado natural	8	20	708205	8,60
	10	20	708206	8,95
	12,5	20	708207	10,35
	15	20	708208	11,10
	17,5	20	708209	11,70
	20	20	708210	12,05
	22,5	20	708211	13,10
	25	20	708212	14,80
	27,5	20	708213	15,60
	30	20	708214	16,55
Aluminio anodizado oro	8	20	708250	8,60
	10	20	708251	8,95
	12,5	20	708252	10,35
Acero inoxidable	8	20	708644	19,75
	10	20	708646	20,35
	12,5	20	708648	21,15
	15	20	708650	22,30
	17,5	20	708652	23,45
	20	20	708654	24,25
	22,5	20	708656	25,60
	25	20	708658	27,25
	27,5	20	708660	28,35
Acero inoxidable cepillado	10	20	708675	23,90
	12,5	20	708676	24,75

NUEVO

TEKNO-ANGLE PVC

Serie 700

Longitud: 2'70 m.

Descripción	H (mm)	Pack	Ref.	Euros
PVC Blanco	8	100	700401	1,35
	10	100	700601	1,40



Sobre pedido se pueden fabricar la misma gama de color de la serie 877 TEKNO-TRIM

TEKNO-ANGLE METAL

Serie 708

Longitud: 2'70 m.

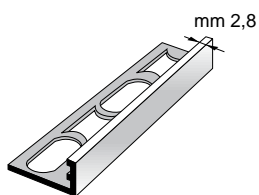

Descripción	H (mm)	Pack	Ref.	Euros
Aluminio cromado brillante	8	20	708295	15,95
	10	20	708296	16,65
	12,5	20	708297	18,35
Aluminio oro brillante	8	20	708340	15,95
	10	20	708341	16,65
	12,5	20	708342	18,35
Aluminio lacado blanco	8	20	708385	11,20
	10	20	708386	11,85
	12,5	20	708387	12,60
Aluminio lacado crema	8	20	708430	11,20
	10	20	708431	12,20
	12,5	20	708432	12,90
Aluminio lacado perla	8	20	708475	11,20
	10	20	708476	12,20
	12,5	20	708477	12,90
Aluminio lacado beige	8	20	708520	11,20
	10	20	708521	12,20
	12,5	20	708522	12,90
Aluminio lacado gris	8	20	708545	11,20
	10	20	708546	12,20
	12,5	20	708547	12,90
Aluminio lacado gris claro	8	20	708590	11,20
	10	20	708591	12,20
	12,5	20	708592	12,90
Aluminio lacado rojo	8	20	708635	11,20
	10	20	708636	12,20
	12,5	20	708637	12,90
Aluminio lacado negro	8	20	708680	11,20
	10	20	708681	12,20
	12,5	20	708682	12,90

TEKNO-ROUND METAL

Serie 732

Longitud: 2'70 m.

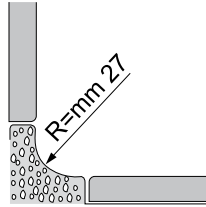

Color	H (mm)	Pack	Ref.	Euros
Aluminio anodizado natural	8	10	732031	21,85
	10	10	732032	22,15
	12,5	10	732033	22,45
Aluminio lacado blanco	8	10	732071	26,10
	10	10	732072	26,40
	12,5	10	732073	26,70
Acero inoxidable	8	10	732021	33,75
	10	10	732022	34,45
	12,5	10	732023	35,30

Piezas de ángulo
(Blíster 2 piezas)

Color	H (mm)	Ref.	Euros
Aluminio anodizado natural	Externo	732075	15,35
	Interno	732077	15,35
Aluminio lacado blanco	Externo	732083	15,35
	Interno	732085	15,35
Acero inoxidable	Externo	732087	24,05
	Interno	732089	24,05

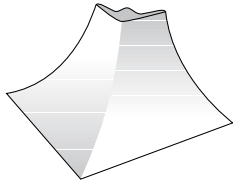

Externo

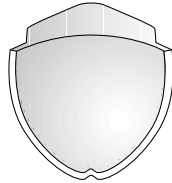

Interno

TEKNO-ROUND PVC

Serie 732

Longitud: 2'70 m.

TEKNO-ROUND

Blíster 2 piezas

Piezas de ángulo

Color	H (mm.)	Pack	Ref.	Euros
Blanco	8	20	732800	10,75
Blanco	10	20	732801	11,30
Gris claro	8	20	732805	10,75
Gris claro	10	20	732806	11,30
Gris piedra	8	20	732810	10,75
Gris piedra	10	20	732811	11,30
Beige	8	20	732815	10,75
Beige	10	20	732816	11,30

Ref. A	Ref. B	Ref. C	Ref. D	Euros
732850	732851	732852	732853	4,40
732860	732861	732862	732863	4,40
732870	732871	732872	732873	4,40
732880	732881	732882	732883	4,40

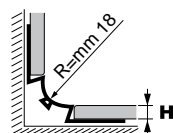

H=mm 8

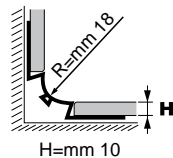

H=mm 10

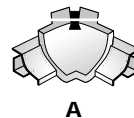

A

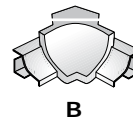

B

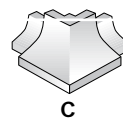

C



D

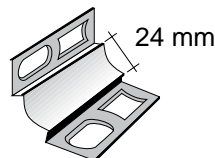

TEKNO-ROUND B

Serie 732



Longitud: 3 m.

Color	Medidas	Pack	Ref.	Euros
Acero inoxidable	30 x 30	20	732990	32,85
Acero inoxidable adhesivo	30 x 30	20	732991	40,75

Piezas de ángulo (Blíster 2 piezas)

PIEZAS ESPECIALES (PVC efecto Cromo Inox)	Pack	Ref.	Euros
Modelo A - Angulo externo	4	732515	4,50
Modelo B - Angulo interno 3 perfiles	4	732516	4,50
Modelo C - Angulo interno	4	732517	4,50
Modelo D - Cierres lateral	4	732518	4,50

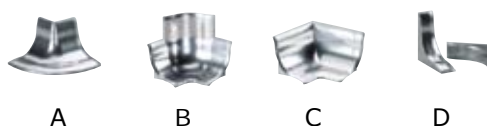
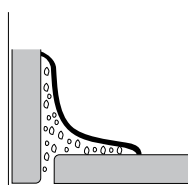
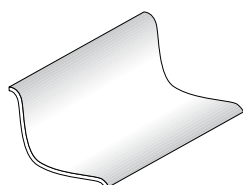

TEKNO-BAÑO PVC

Serie 732

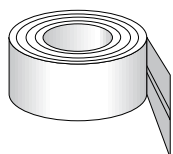

Longitud: 3,5 m.

Material / Color	Fijación	Pack	Ref.	Euros
Cinta PVC color blanco	Adhesivo	12	732020	9,75

TEKNO-BAÑO ALUMINIO

Serie 732



Longitud: 2,70 m.

Material / Color	Fijación	Pack	Ref.	Euros
Perfil PVC color blanco		20	732490	9,55
Perfil PVC color blanco	Adhesivo	20	732470	12,65
Aluminio lacado blanco	Adhesivo	20	732460	18,20
Piezas de ángulo y terminación (blíster 4 piezas) PVC			732480	4,60

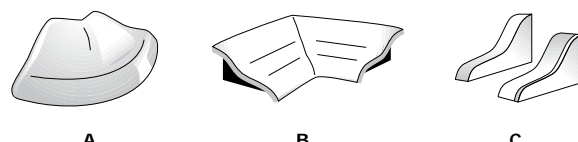
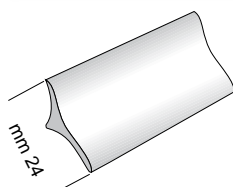
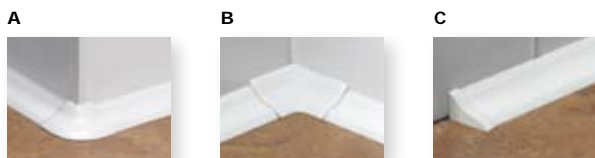

TEKNO-BORD INOX

Serie 732

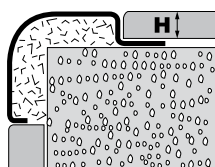

Longitud: 2,70 m

Color	H (mm)	Pack	Ref.	Euros
Acero inoxidable	8 mm	10	732994	39,75
	10 mm	10	732995	40,55
	12,5	10	732996	41,50

TEKNO-STEP 52 mm

Serie 797

Longitud: 2,70 m.

BASE ALUMINIO + GOMA

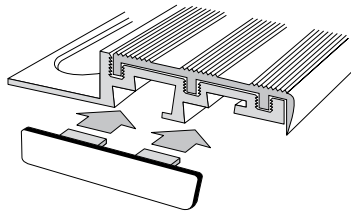
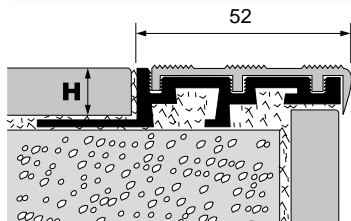

Descripción	H (mm)	Pack	Ref.	Euros
Perfil de aluminio + Goma PVC Gris	10	10	797461	41,20
	12,5	10	797521	43,35
	15	10	797581	45,80
Perfil de aluminio + Goma PVC Avellana	10	10	797481	41,20
	12,5	10	797541	43,35
	15	10	797601	45,80
Perfil de aluminio + Goma PVC Negro	10	10	797501	41,20
	12,5	10	797561	43,35
	15	10	797621	45,80

Descripción	Color	Ref.	Euros
Cierre lateral 52 mm.	Gris	797895	3,30
	Avellana	797896	3,30
	Negro	797897	3,30

Blister 2 piezas: Derecha + Izquierda

TEKNO-STEP 24 mm

Serie 797

Longitud: 2,70 m.

BASE ALUMINIO + GOMA

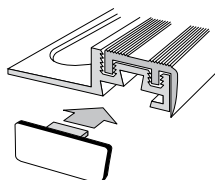
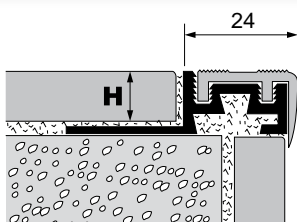

Descripción	H (mm)	Pack	Ref.	Euros
Perfil de aluminio + Goma PVC Gris	10	10	797061	28,85
	12,5	10	797121	29,85
Perfil de aluminio + Goma PVC Avellana	10	10	797081	28,85
	12,5	10	797141	29,85
Perfil de aluminio + Goma PVC negro	10	10	797101	28,85
	12,5	10	797161	29,85

Blister 2 piezas: Derecha + Izquierda

Descripción	Color	Ref.	Euros
Cierre lateral 24 mm.	Gris	797890	3,00
	Avellana	797891	3,00
	Negro	797892	3,00

TEKNO-PELDAÑO

Serie 797

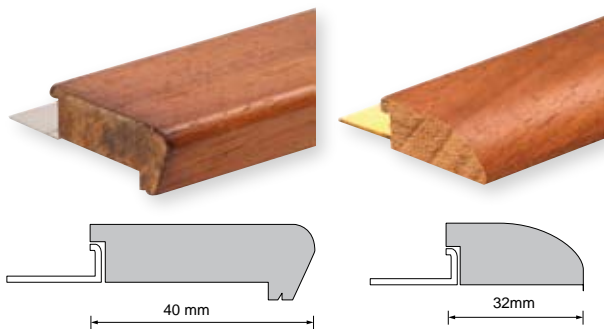

Longitud: 3 m.

Descripción	Ancho	H (mm)	Pack	Ref.	Euros
Iroco Natural	40 mm	11 mm	10	797015	42,15
Iroco Barnizado	40 mm	11 mm	10	797025	59,30
Iroco Natural	32 mm	11 mm	10	797115	38,15
Iroco Barnizado	32 mm	11 mm	10	797125	47,10

TEKNO-PELDAÑO CLÁSICO

Serie 797

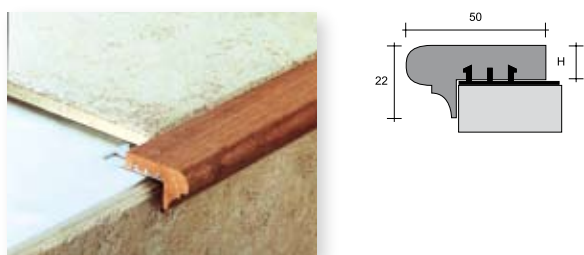

Longitud: 2,70 m.

Descripción	Ancho	H (mm)	Pack	Ref.	Euros
Madera de roble americano	50 mm	10 mm	5	797175	87,00
	50 mm	12,5 mm	5	797180	89,50
	50 mm	15 mm	5	797185	92,50
	50 mm	22 mm	5	797190	96,15
Madera de mahogany	50 mm	10 mm	5	797195	80,35
	50 mm	12,5 mm	5	797200	82,85
	50 mm	15 mm	5	797205	85,80
	50 mm	22 mm	5	797210	89,50

TEKNO-PELDAÑO REDONDO

Serie 797

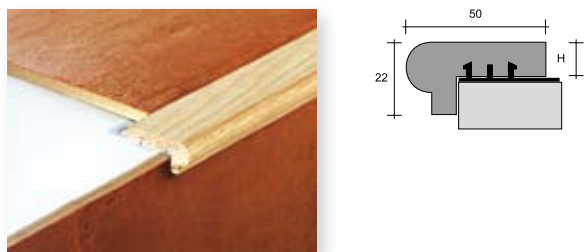

Longitud: 2,70 m.

Descripción	Ancho	H (mm)	Pack	Ref.	Euros
Madera de roble americano	50 mm	10 mm	5	797215	72,95
	50 mm	12,5 mm	5	797220	75,70

TEKNO-PELDAÑO RECTO

Serie 797

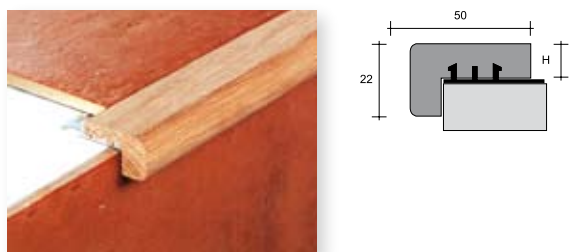

Longitud: 2,70 m.

Descripción	Ancho	H (mm)	Pack	Ref.	Euros
Madera de roble americano	50 mm	10 mm	5	797225	87,00
	50 mm	12,5 mm	5	797230	89,50

TEKNO-STEP SM METAL

Serie 797

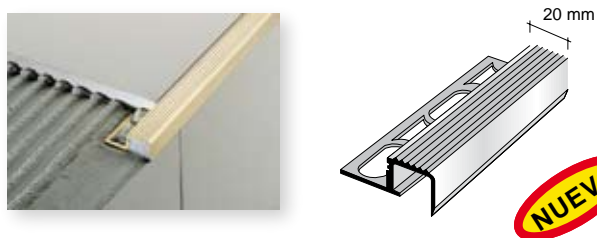

Longitud: 2,70 m.

Descripción	Longitud	H (mm)	Pack	Ref.	Euros
Latón natural	270 cm	10 mm	20	797972	66,55
Latón natural	270 cm	12,5 mm	20	797973	70,35
Aluminio natural	270 cm	10 mm	20	797970	16,95
Aluminio natural	270 cm	12,5 mm	20	797971	17,95

TEKNO-JOINT PVC

Serie 731

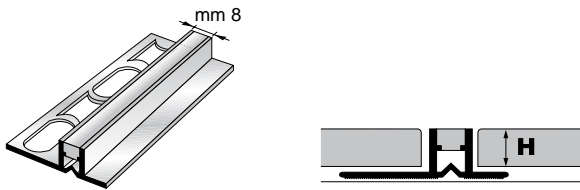

Longitud: 2'70 m.

JUNTA DE DILATACIÓN

Color	H (mm.)	Pack	Ref.	Euros
Gris perla	10	80	731603	2,80
Marrón	10	80	731608	2,80
Negro	10	80	731612	2,80
Gris perla	12,5	80	731623	2,95
Marrón	12,5	80	731628	2,95
Negro	12,5	80	731632	2,95
Gris perla	15	64	731643	3,30
Marrón	15	64	731648	3,30
Negro	15	64	731652	3,30
Gris perla	20	56	731663	3,75
Marrón	20	56	731668	3,75
Negro	20	56	731672	3,75
Gris perla	25	40	731683	4,25
Marrón	25	40	731688	4,25
Negro	25	40	731692	4,25

TEKNO-JOINT METAL + GOMA

Serie 731

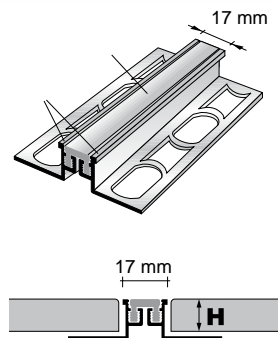

Longitud: 2'70 m.

JUNTA DE DILATACIÓN

Descripción	Goma	H (mm)	Pack	Ref.	Euros
Latón	Negra	8	10	731950	77,80
	Gris	8	10	731960	77,80
Latón	Negra	10	10	731951	80,15
	Gris	10	10	731961	80,15
Latón	Negra	12,5	10	731952	84,40
	Gris	12,5	10	731962	84,40
Latón	Negra	15	10	731953	87,50
	Gris	15	10	731963	87,50
Latón	Negra	20	10	731954	95,05
	Gris	20	10	731964	95,05
Aluminio	Negra	8	10	731970	27,90
	Gris	8	10	731980	27,90
Aluminio	Negra	10	10	731971	28,45
	Gris	10	10	731981	28,45
Aluminio	Negra	12,5	10	731972	29,30
	Gris	12,5	10	731982	29,30

TEKNO-JOINT NF PVC

Serie 731

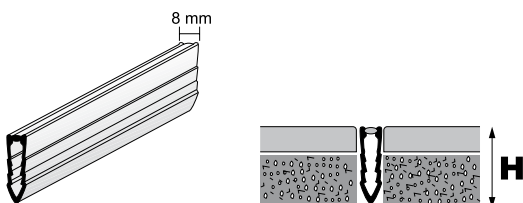

Longitud: 2'70 m.

JUNTA DE DILATACIÓN

Color	H (mm.)	Pack	Ref.	Euros
Gris	25	40	731800	4,40
Gris	30	40	731805	4,95
Gris	35	40	731810	5,15
Gris	45	20	731820	6,35

TEKNO-DECOR METAL

Serie 795

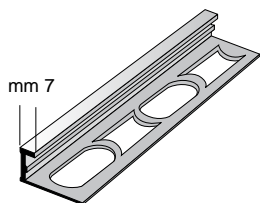

Longitud: 2'70 m.

Descripción	H (mm)	Pack	Ref.	Euros
Latón natural	8	20	795620	33,30
	10	20	795622	34,20
	12,5	20	795624	35,75
Latón pulido	8	20	795654	42,70
	10	20	795656	42,95
	12,5	20	795658	44,80
Latón cromado	8	20	795900	60,10
	10	20	795902	61,65
	12,5	20	795904	63,85
Aluminio anodizado natural	8	20	795930	13,95
	10	20	795932	14,75
	12,5	20	795934	15,50
Acero inoxidable pulido AISI 304	8	20	795906	24,85
	10	20	795908	25,10
	12,5	20	795910	25,55

TEKNO-STYLE METAL

Serie 795

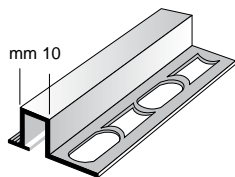

Longitud: 2'70 m.

Descripción	H (mm)	Pack	Ref.	Euros
Aluminio anodizado natural	10	20	795380	14,75
	12,5	20	795382	15,50
Latón natural	10	10	795302	40,85
	12,5	10	795304	45,80
Latón pulido	8	10	795324	44,95
	10	10	795326	44,95
	12,5	10	795328	51,15
Acero inox. cepillado	10	10	795350	30,60
	12,5	10	795352	32,20

TEKNO-LIST METAL

Serie 793

Ancho 10 mm



Longitud: 2'70 m

Descripción	Pack	Ref.	Euros
Aluminio anodizado natural	20	793255	10,05
Aluminio anodizado cromado	20	793252	14,55
Aluminio anodizado oro brillante	20	793253	14,55
Aluminio lacado blanco	20	793254	14,90
Aluminio lacado rojo	20	793260	14,90
Aluminio lacado negro	20	793261	14,90
Acero inox. brillante	20	793286	14,75
Acero inox. cepillado	20	793287	20,25

Ancho 25 mm

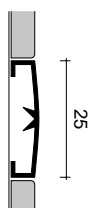

Descripción	Pack	Ref.	Euros
Aluminio anodizado natural	20	793270	14,95
Aluminio anodizado cepillado	20	793244	20,96
Aluminio anodizado cromado	20	793272	19,85
Aluminio anodizado oro brillante	20	793273	19,85
Aluminio lacado blanco	20	793274	20,50
Aluminio lacado rojo	20	793280	20,50
Aluminio lacado negro	20	793281	20,50

TEKNO-NIVEL METAL

Serie 792



Para moqueta

Longitud: 2'70 m.

Descripción	H (mm)	Pack	Ref.	Euros
Latón Natural	8	10	792890	38,90
	10	10	792892	42,45
	12,5	10	792894	55,40
Latón pulido	10	10	792952	51,55
	12,5	10	792954	64,45
Aluminio anodizado natural	8	10	792010	12,25
	10	10	792012	13,95
	12,5	10	792014	17,65

TEKNO-NIVEL METAL

Serie 792



Para pavimento

Longitud: 2'70 m.

Descripción	H (mm)	Pack	Ref.	Euros
Latón Natural	10	10	792122	41,60
	12,5	10	792123	51,95
	14	10	792124	60,15
Latón pulido	10	10	792152	51,55
	12,5	10	792153	61,90
	14	10	792154	70,90
Aluminio anodizado natural	8	10	792181	13,85
	10	10	792182	15,10
	12,5	10	792183	16,75
	14	10	792184	18,25
Acero inox	10	10	792094	28,50
Madera roble americano	10	10	792550	44,70
	12,5	10	792554	52,40
	15	10	792558	62,60

TEKNO-JUNTAS METAL

Serie 730

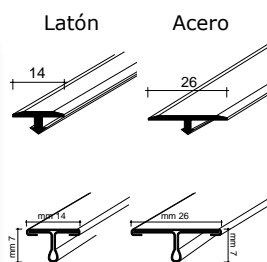
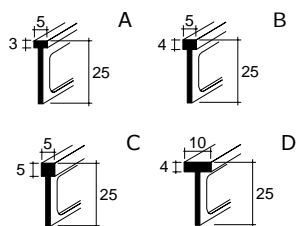

Descripción	Long	Pack	Ref.	Euros
Latón extrusionado natural (A)	2,55	50	730977	20,35
Latón extrusionado natural (B)	2,55	50	730987	24,30
Latón extrusionado natural (C)	2,55	50	730997	26,85
Latón extrusionado natural (D)	2,55	50	730907	41,20

Descripción	Long	Ancho	Pack	Ref.	Euros
Latón extrusionado natural	2,70	14 mm	50	730087	19,75
Latón extrusionado natural	2,70	26 mm	20	730088	34,50
Latón cromado	2,70	14 mm	50	730086	39,30
Latón cromado	2,70	26 mm	20	730089	52,30
Acero inoxidable pulido	2,70	14 mm	30	730092	23,30
Acero inoxidable pulido	2,70	26 mm	20	730096	32,90
Acero inoxidable cepillado	2,70	14 mm	30	730093	28,90
Acero inoxidable cepillado	2,70	26 mm	20	730097	39,35

TEKNO-EXTERN METAL

Externos para esquinas

Serie 776

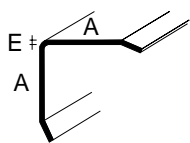

Longitud: 3 m.

Descripción	Ancho (mm) A x A x E	Pack	Sin Adhesivo		Adhesivo	
			Ref.	Euros	Ref.	Euros
Acero inoxidable	15 x 15 x 0,6	30	776888	13,10	776938	17,85
	20 x 20 x 0,6	30	776898	15,80	776948	20,55
	25 x 25 x 0,6	30	776908	18,60	776958	23,35
	30 x 30 x 1	20	776008	27,70	776148	31,95
Acero inoxidable alimentario	40 x 40 x 1	20	776018	35,80	776158	40,05
	50 x 50 x 1	20	776028	42,55	776168	46,80

TEKNO-EXTERN METAL

Externos para esquinas

Serie 776

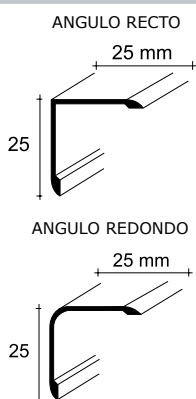

Longitud: 3 m.

Descripción	Pack	Sin Adhesivo		Adhesivo	
		Ref.	Euros	Ref.	Euros
Anodizado natural (ángulo recto)	30	776068	12,45	776098	15,85
Anodizado oro (ángulo recto)	30	776078	12,45	776108	15,85
Anodizado bronce (ángulo recto)	30	776089	12,45	776118	15,85
Lacado blanco (ángulo recto)	30	776128	16,30	776208	19,65
Anodizado natural (án. redondo)	30	776688	15,35	776894	18,70
Anodizado oro (ángulo redondo)	30	776890	15,35	776896	18,70
Lacado blanco (ángulo redondo)	30	776900	19,15	776916	22,50

ESQUINA YESERO

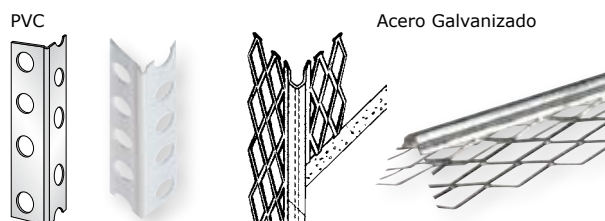

Descripción	Long	Pack	Ref.	Euros
Perfil esquina yesero blanco PVC	2,5 m	100	700800	0,95
Esquinero yesero de acero galvanizado	2,5 m	100	700840	1,50

PERFIL para MONOCAPA

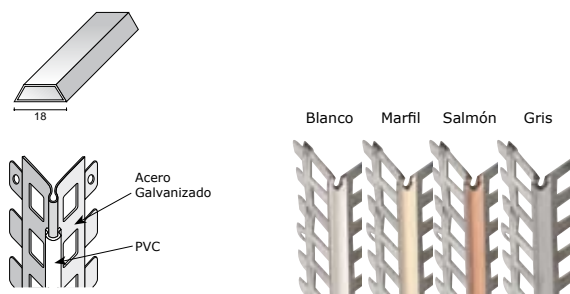

Descripción	Long	Ancho	Pack	Ref.	Euros
Monocapa hueco PVC	2,60 m	18 mm	100	700810	0,82
Monocapa acero galvanizado con recubrimiento PVC blanco	2,50 m	41 mm	25	700860	3,95
PVC marfil	2,50 m	41 mm	25	700861	4,15
PVC salmón	2,50 m	41 mm	25	700862	4,15
PVC gris	2,50 m	41 mm	25	700863	4,15

ANTIDESLIZANTE

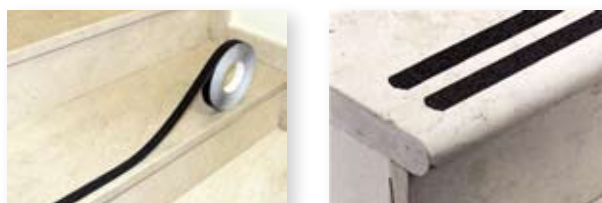

Descripción	Long	Ancho	Pack	Ref.	Euros
Cinta antideslizante negra	18,2 m	19 mm	4	723002	26,15
Cinta antideslizante negra	18,2 m	25 mm	4	723004	35,20
Cinta antideslizante negra	18,2 m	50 mm	4	723006	66,00
Pinza de cortar perfil PVC indicador graduable de ángulo				216VB	20,45

CALENDARIO DE FERIAS 2007



CEVISAMA - VALENCIA

Del 6 al 10-02-2007
Pabellón 6 Stand C - 107

FERROFORMA - BILBAO

Del 7 al 10-03-2007
Pabellón 3 Stand D - 54

CONSTRUMAT - BARCELONA

Del 14 al 10-05-2007
Pabellón 8 Stand A - 107

CERSAIE - BOLOGNA (ITALIA)

Del 02 al 06-10-2007

BATIMAT - PARIS (FRANCIA)

Del 05 al 10-11-2007

BIG 5 SHOW - DUBAÏ (EMIRATOS ARABES UNIDOS)

Del 26 al 30-11-2007

CONDICIONES GENERALES DE VENTA

PRECIOS

- Los precios de tarifa se entienden siempre franco Esparreguera.
- Los precios indicados en las tarifas se incrementarán con el I.V.A. y, en su caso, con el recargo de equivalencia correspondiente.
- Precios Vigentes hasta la edición de nueva tarifa, salvo error de impresión.

PEDIDOS

- Con el fin de evitar errores, rogamos a nuestros clientes redacten los pedidos con los números y referencias de las tarifas.

PLAZO DE ENTREGA

- Nuestros plazos de entrega son a título orientativo y, por lo tanto, no pueden derivar ninguna indemnización en caso de retraso.

EXPEDICION

- Los portes serán pagados para expediciones de un importe mínimo facturado de 375 euros. Para Exportación e Islas Canarias consultar condiciones particulares
- Para las expediciones con carácter urgente, solicitadas por el cliente, los portes correrán a cargo del mismo.

CONDICIONES DE PAGO

- Transferencia anticipada: 2%
- Reposición o recibo a la vista a los 10 días: 2%
- Financiación máxima: 90 días
- Domiciliación bancaria (20 dígitos) en todos los efectos.
- Los efectos impagados sufrirán un recargo por los gastos de devolución y demora correspondientes.
- Las facturas de importe inferior a 200 euros se abonarán siempre por recibo a la vista domiciliado, reposición a un máximo de 30 días, o contrareembolso.
- El material entregado permanece de nuestra propiedad hasta el pago total y definitivo.

RECLAMACIONES

- Sólo se admiten en un plazo de 8 días después de la recepción del material.
- Los gastos generados por devolución del género serán a cargo del cliente.
- Tomecanic se reserva el derecho a modificar cualquier característica o referencia de los artículos sin previo aviso, no derivándose en ningún caso derecho a reclamación.

GARANTIA

- La garantía se limita a la reposición de piezas toda vez reconocido defecto de fabricación, y su utilización en condiciones normales de trabajo.
- El bono de garantía debe ser devuelto a TOMECHANIC HISPANIA debidamente cumplimentado, en los primeros diez días siguientes a la adquisición de la máquina por el usuario. Imprescindible sello del establecimiento expedidor.
- En el caso de reparación los gastos de devolución-expedición correrán a cargo del cliente.

JURISDICCION

- Las partes contratantes se someten expresamente al fuero y jurisdicción del Juzgado y Tribunales de Partido de Sant Feliu de Llobregat, con renuncia expresa a su propio domicilio si lo tuviesen diferente.

Las fotografías y características de nuestros productos no son contractuales.

Con el afán de mejora y perfeccionamiento de sus productos TOMECHANIC se reserva el derecho a modificar las características en cualquier momento y sin previo aviso.

UTILLAJE Y CORTADORES



Ref.	Dimensiones	€
77777-1	80 x 180 x 40 cm	93,00



Ref.	Dimensiones	€
99999-1	133 x 225 x 45cm	198,00

PERFILES



Ref.	Dimensiones	€
66666-1	80 x 180 x 50 cm	84,00

CORTADORES, DISCOS Y CORONAS

Vitrina giratoria con cierre de seguridad

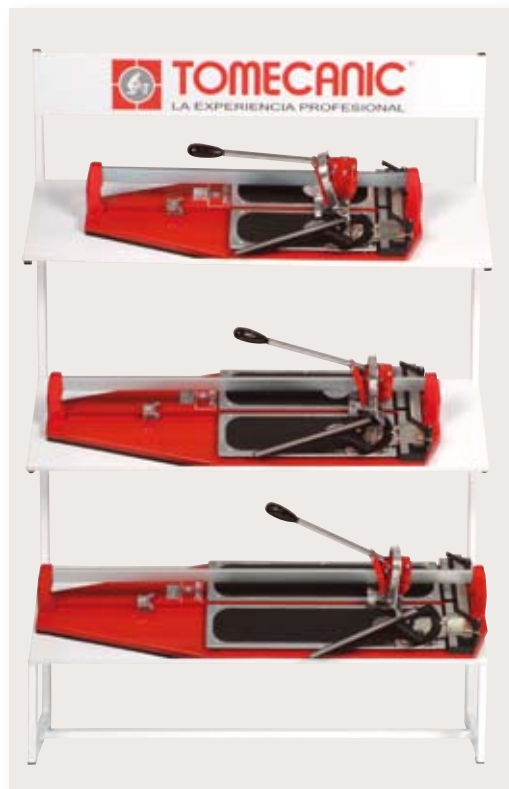

Ref.	Dimensiones	€
88888-1	100 x 180 x 60 cm	133,00



Ref.	Dimensiones	€
013835-1	55 x 55 x 185 cm	1.040,00

