

# SISTEMI UNIFORM

5000/S	5000/S LA219	Complanare 5000/S	5000/S BRONZO	UNITHERM	Verbund 5000/S
					
Soft-Line	Soft-Line LA236	Soft-Line Plus	Soft-Line/S	N68 Soft	Verbund Soft-Line
					
Light/45 con/senza Guida	Light/45 Monoblocco	1000/45	Soft-Line/45	Scorr. Mediterraneo	Verbund/45
					

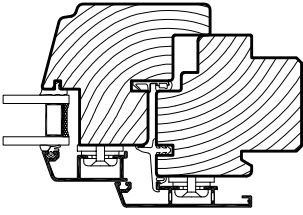

**BATTUTA 15mm – CLIPS GIREVOLI**

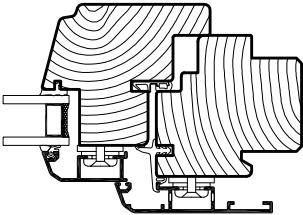
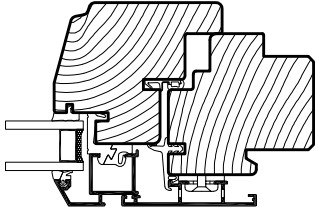
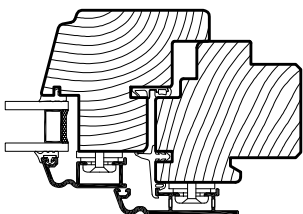
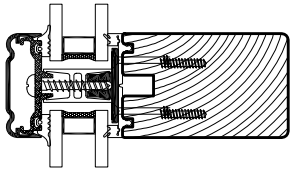
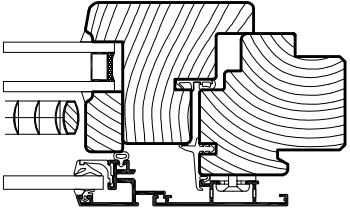
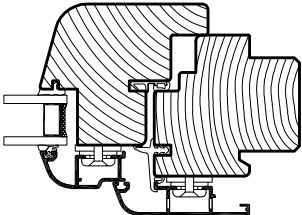
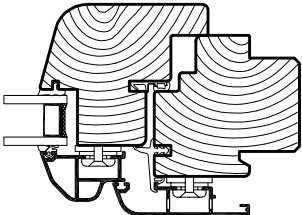
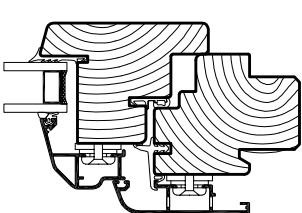
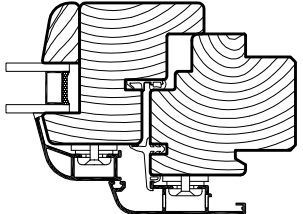
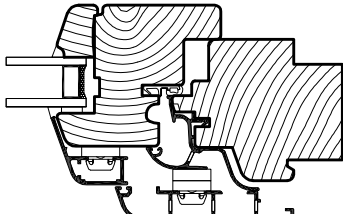
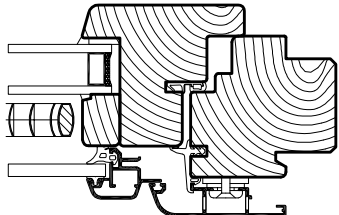
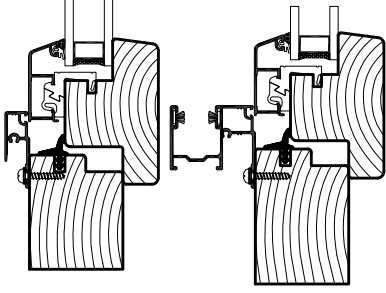
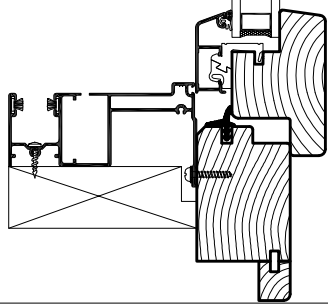
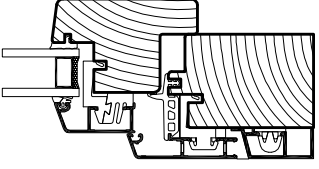
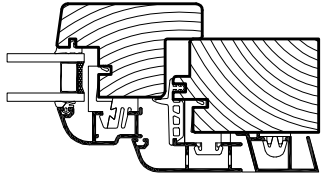
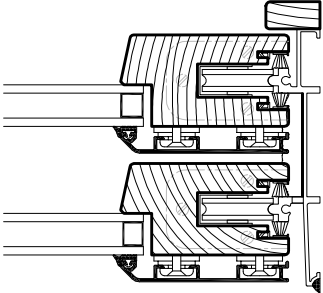
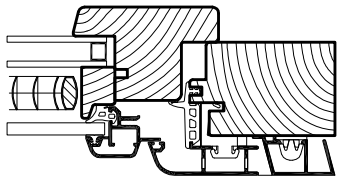
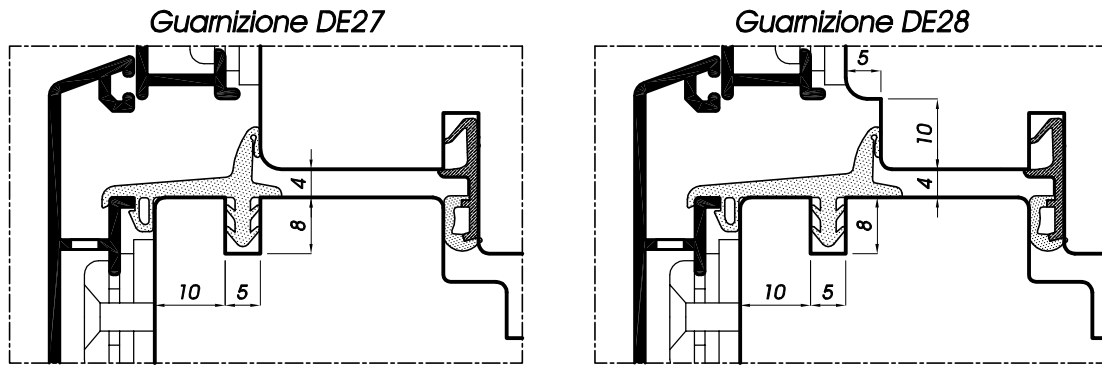
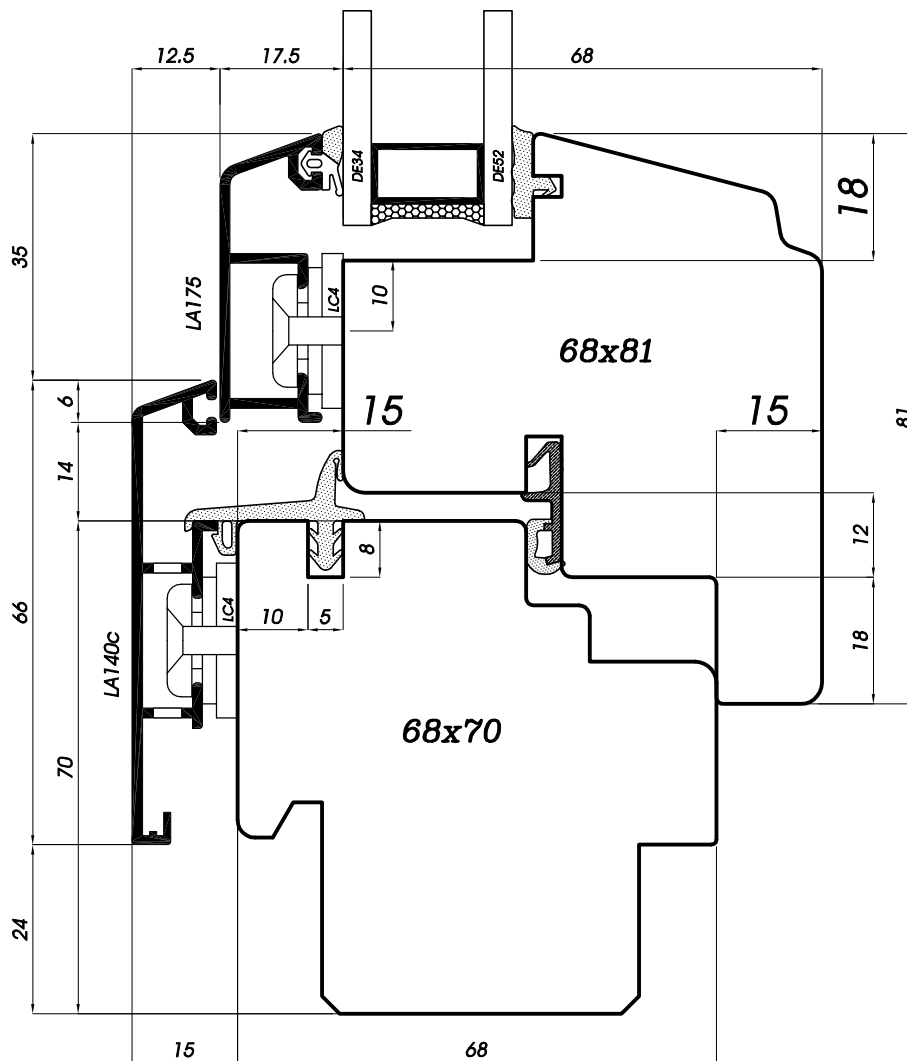

*Sezione verticale traverso inferiore finestra con battuta squadratura anta 15mm*  
*Vertikalschnitt Fenster quer unten mit Außenprofilierung 15mm*  
*Sección vertical travesaño inferior de ventana con galce del escuadrado de la hoja de 15 mms*  
*Coupe verticale traverse inférieure fenêtré avec recouvrement épaisseur 15 mm sur ouvrant*  
*Vertical section of the window's lower ledger with rabbet for a squared wing 15mm*



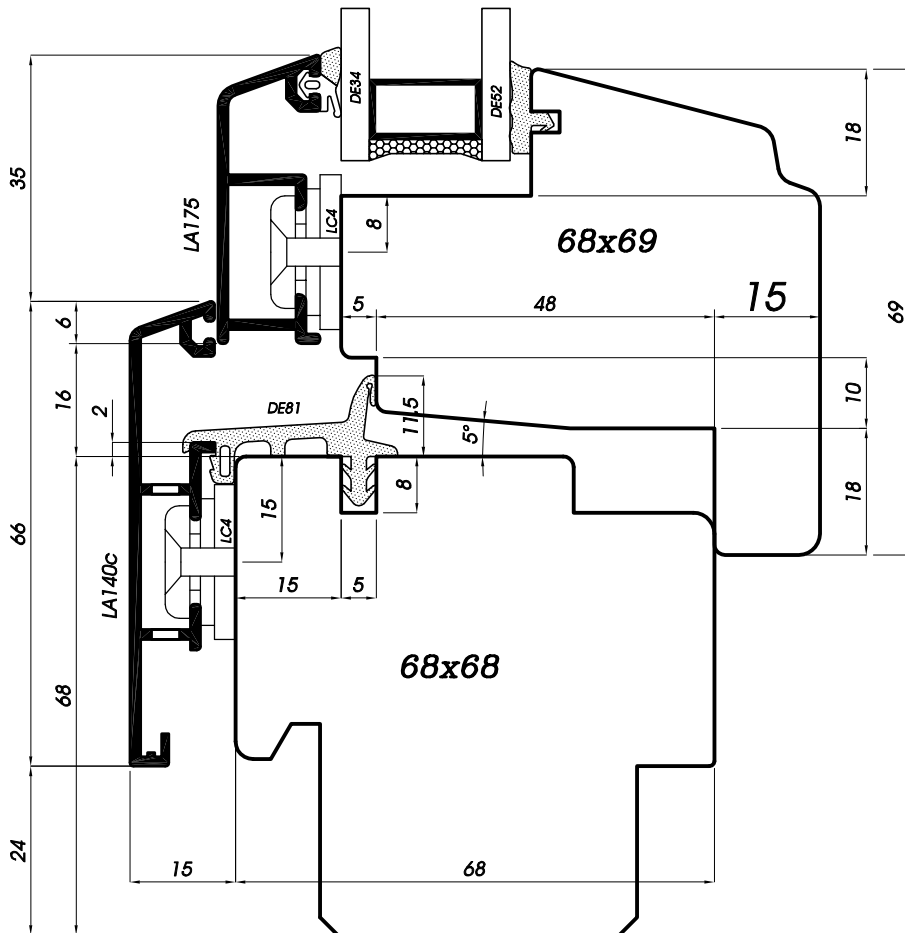
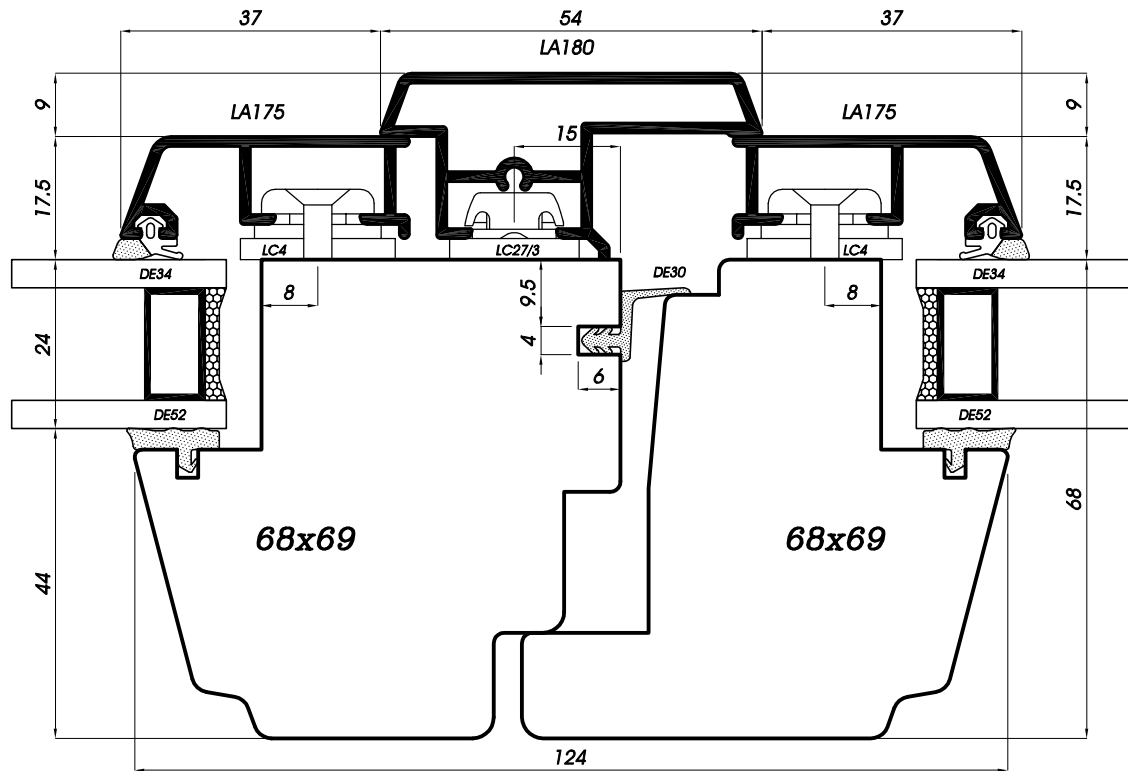

**Sezione verticale trasverso inferiore finestra e nodo centrale finestra con guarnizione DE81**  
**Vertikalschnitt Fenster quer unten und Stulpprofil mit Dichtung DE81**  
**Sección vertical travesaño inferior de ventana y nudo central de la ventana con junta DE81**  
**Coupe verticale traverse inférieure fenêtré et battement central avec joint DE81**  
**Vertical section of the window's lower ledger and window's middle point with gasket DE81**

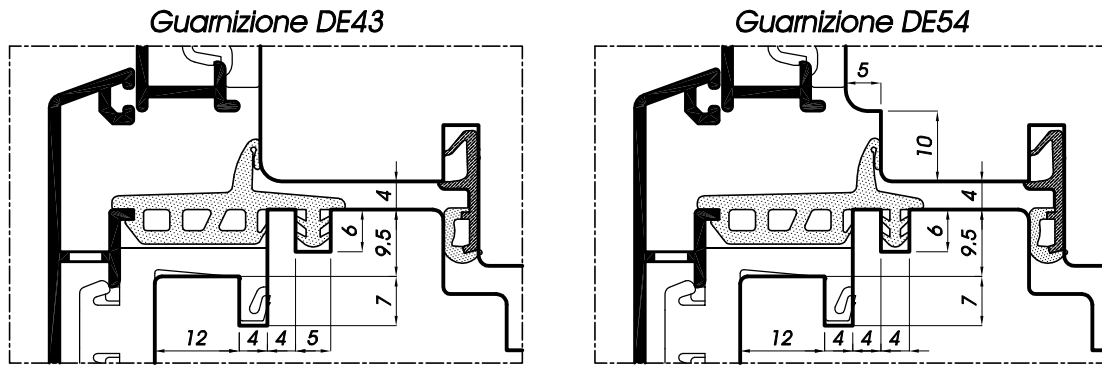

**BATTUTA 15mm – CLIPS A SCATTO**

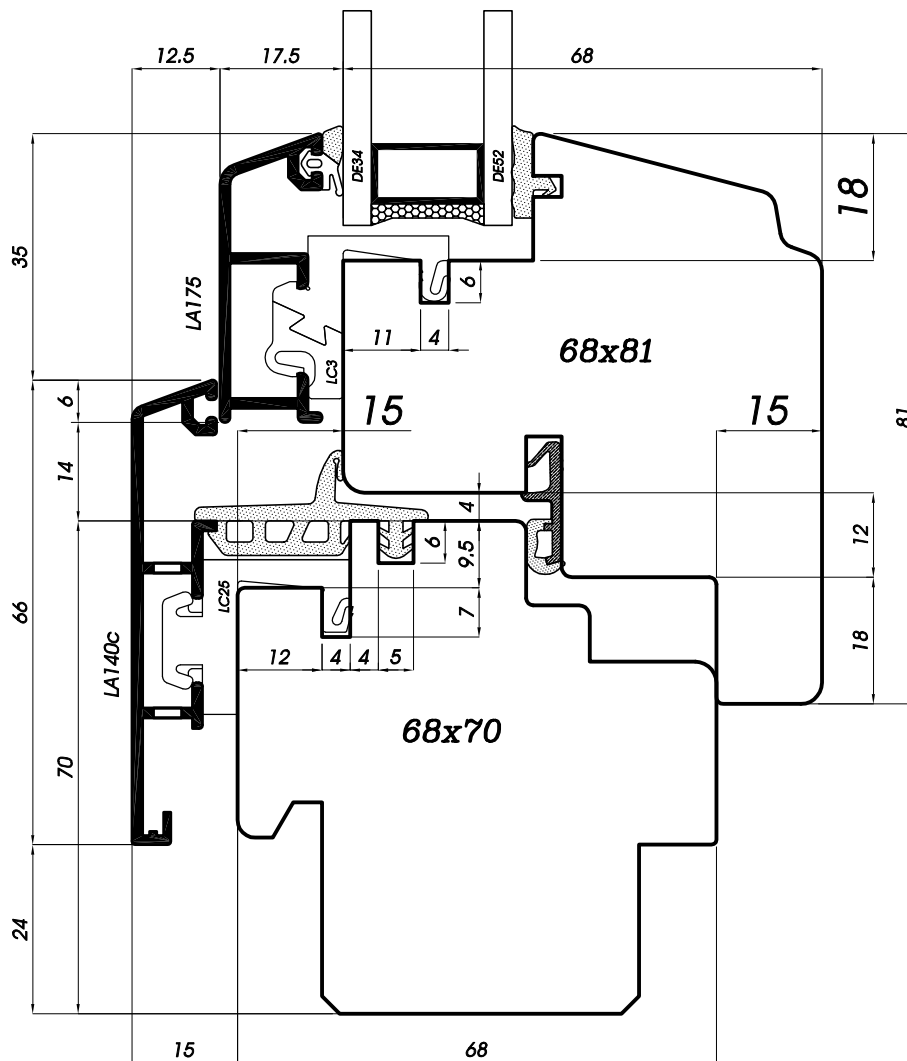

*Sezione verticale trasverso inferiore finestra con battuta squadratura anta 15mm (battuta vetro 18mm)*  
*Vertikalschnitt Fenster quer unten mit Außenprofilierung Flügel 15 mm (Glasfalz 18mm)*  
*Sección vertical travesaño inferior de ventana con galce del escuadrado de la hoja de 15mms (galce cristal de 18mms)*  
*Coupe verticale traverse inférieure fenêtré avec recouvrement épaisseur 15mm sur ouvrant (feuillure à verre 18 mm)*  
*Vertical section of the window's lower ledger with rabbet for a squared wing 15mm (glass rabbet 18 mm)*

**BATTUTA VETRO 20mm**  
**BATTUTA 15mm – CLIPS A SCATTO**

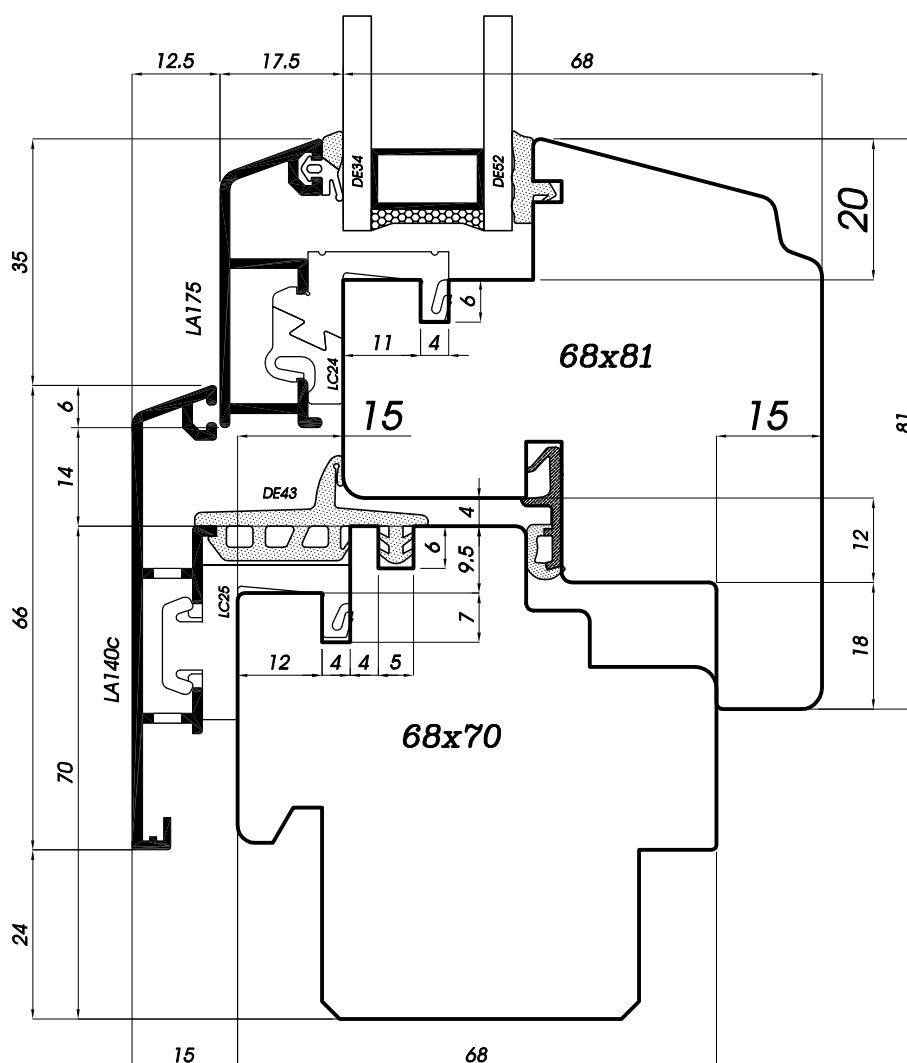

*Sezione verticale trasverso inferiore finestra con battuta squadrata anta 15mm (battuta vetro 20mm)*  
*Vertikalschnitt Fenster quer unten mit Außenprofilierung Flügel 15 mm (Glasfalz 20mm)*  
*Sección vertical travesaño inferior de ventana con galce del escuadrado de la hoja de 15mms (galce cristal de 20mms)*  
*Coupe verticale traverse inférieure fenêtre avec recouvrement épaisseur 15mm sur ouvrant (feuillure à verre 20mm)*  
*Vertical section of the window's lower ledger with rabbet for a squared wing 15mm (glass rabbet 20mm)*

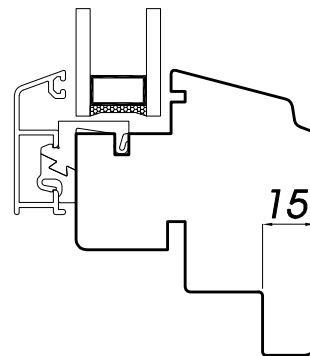
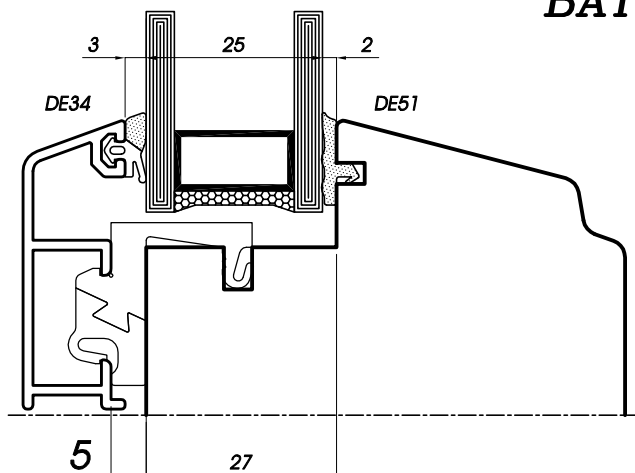
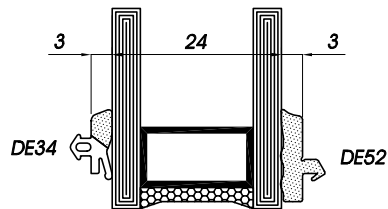
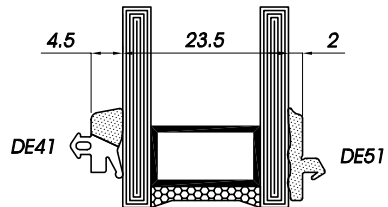
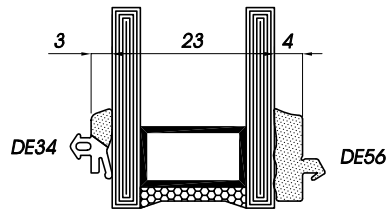
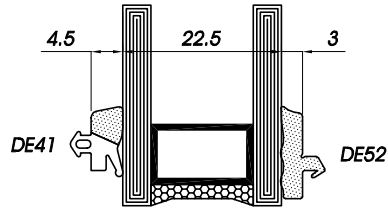
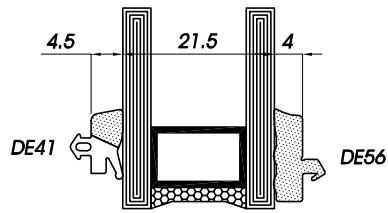

**BATTUTA 15mm**

*Variazione spessori vetro*  
*Abänderung der Glasstärke*  
*Variación de los espesores del vidrio*  
*Variations épaisseurs vitres*  
*Range of the glass' thickness*

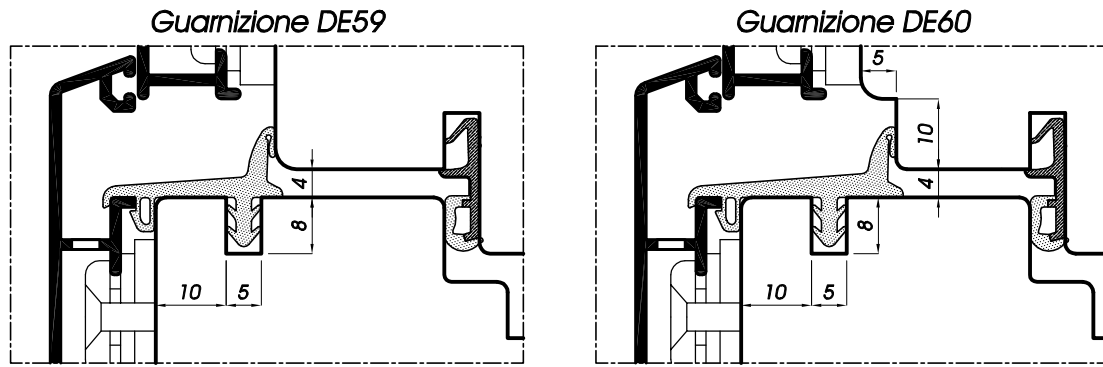

## BATTUTA 17mm — CLIPS GIREVOLI

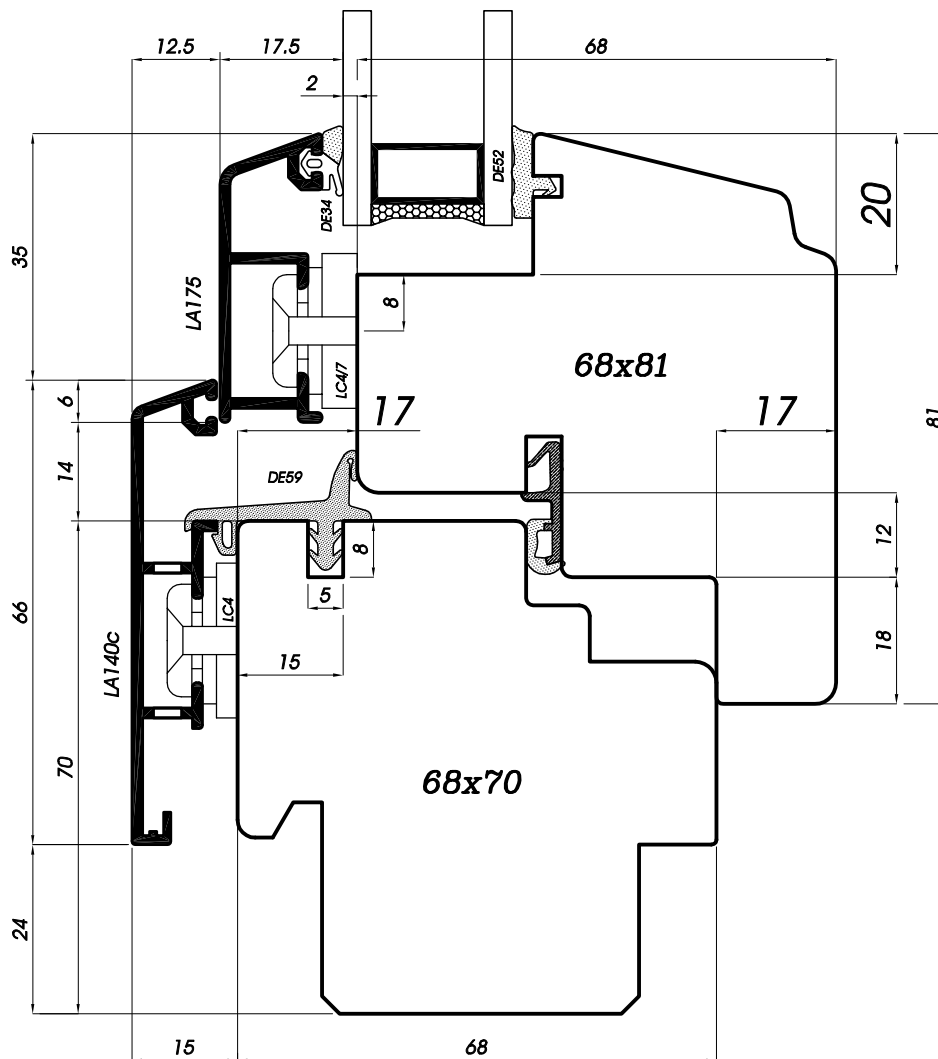

*Sezione verticale traverso inferiore finestra con battuta squadrata anta 17mm (battuta vetro 20mm)*

*Vertikalschnitt Fenster quer unten mit Außenprofilierung Flügel 17 mm (Glasfalz 20mm)*

*Sección vertical travesaño inferior de ventana con galce del escuadrado de la hoja de 17mms (galce cristal de 20mms)*

*Coupe verticale traverse inférieure fenêtré avec recouvrement épaisseur 17mm sur ouvrant (feuillure à verre 20mm)*

*Vertical section of the window's lower ledger with rabbet for a squared wing 17mm (glass rabbet 20 mm)*

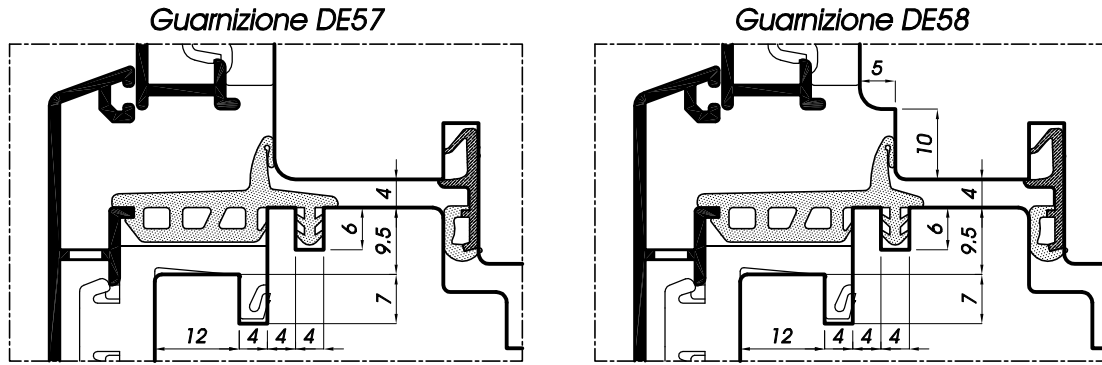

**BATTUTA 17mm — CLIPS A SCATTO**

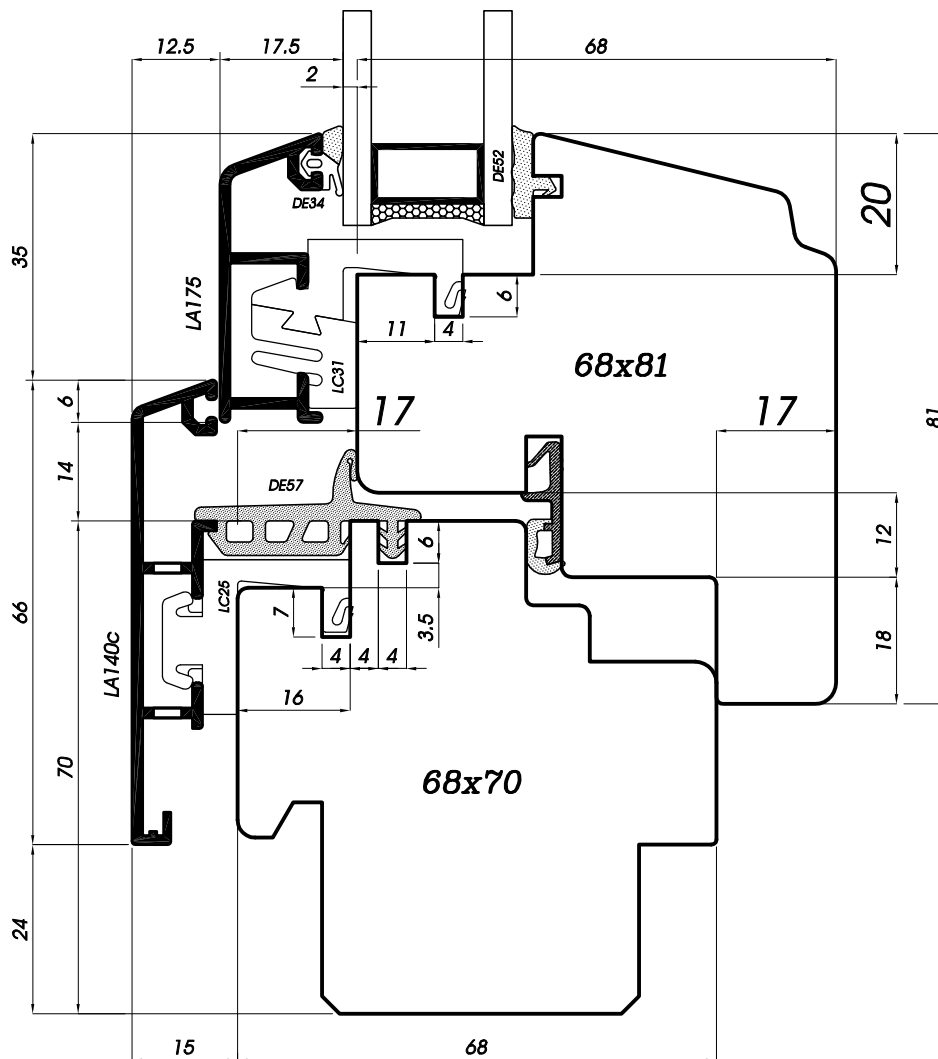

Sezione verticale trasverso inferiore finestra con battuta squadratura anta 17mm (battuta vetro 20mm)

Vertikalschnitt Fenster quer unten mit Außenprofilierung Flügel 17 mm (Glasfalz 20mm)

Sección vertical travesaño inferior de ventana con galce del escuadrado de la hoja de 17mms (galce cristal de 20mms)

Coupe verticale traverse inférieure fenêtre avec recouvrement épaisseur 17mm sur ouvrant (feuillure à verre 20mm)

Vertical section of the window's lower ledger with rabbet for a squared wing 17mm (glass rabbet 20mm)

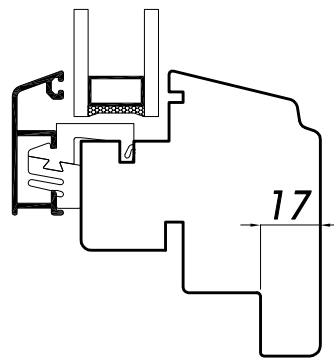
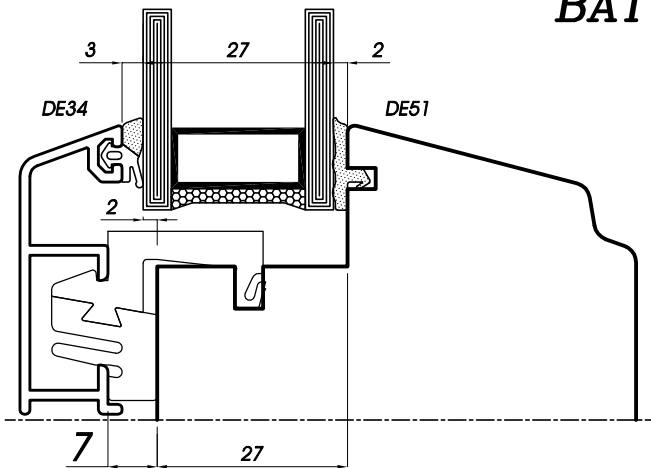
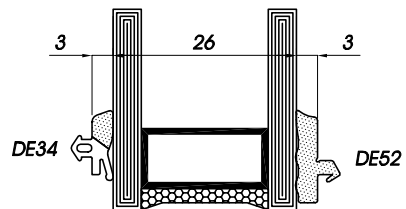
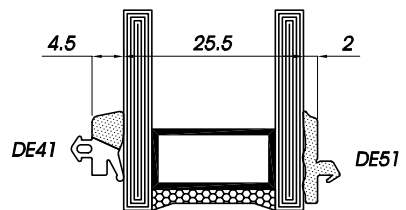
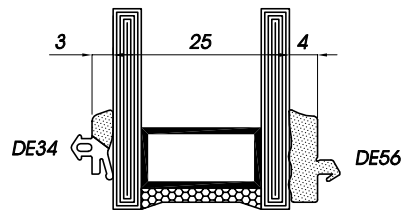
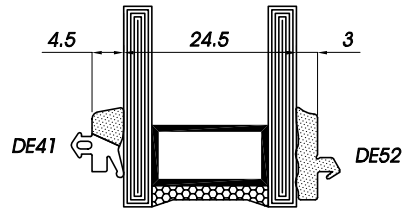
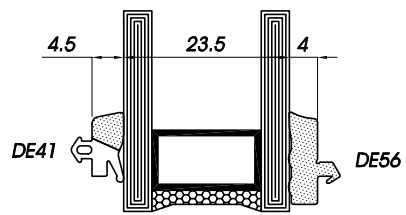

**BATTUTA 17mm**

*Variatione spessori vetro*  
*Abänderung der Glasstärke*  
*Variación de los espesores del vidrio*  
*Variations épaisseurs vitres*  
*Range of the glass' thickness*

DE29

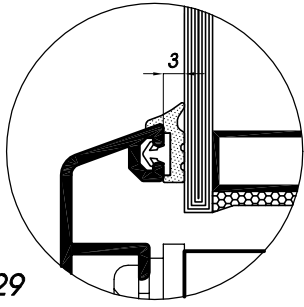

DE32  
con silicone

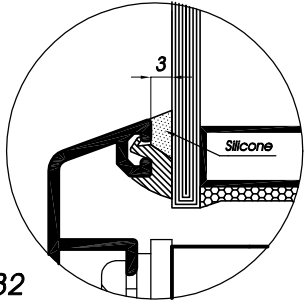

DE34

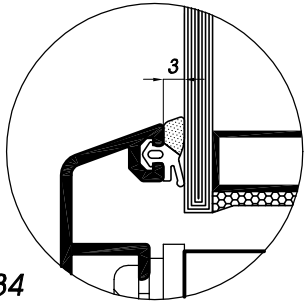

DE41

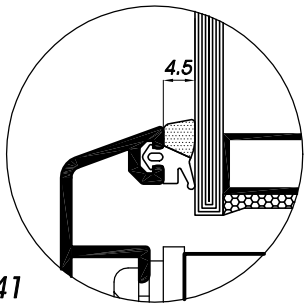

DR01/15  
DR01/18  
DR01/20

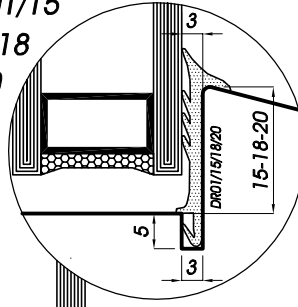

DE65

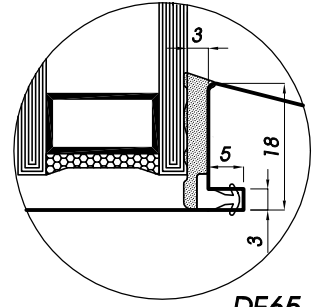

DE51

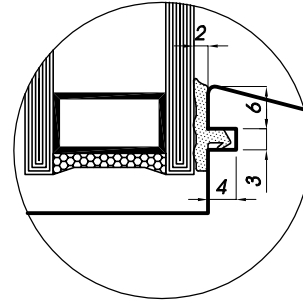

DE52

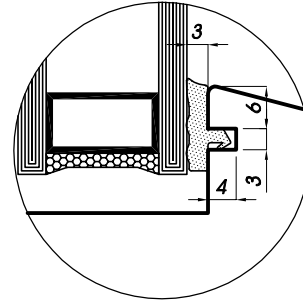

DE56

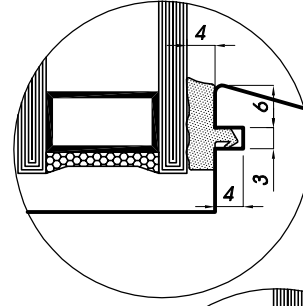

GUARNIZIONI ESTERNO ANTA

GUARNIZIONI INTERNO ANTA

PROFILO ANTA

3-4,5

2-3-4

Nastro  
LG15/3

Guarnizione e nastri di tenuta  
Dichtung und Klebebänder zur Abdichtung  
Juntas y cintas de estanqueidad  
Joints et rubans pour isolation  
Gasket and seal tapes



LC4 -Clips girevole con vite 5mm  
 LC4/7 -Clips girevole con vite 7mm

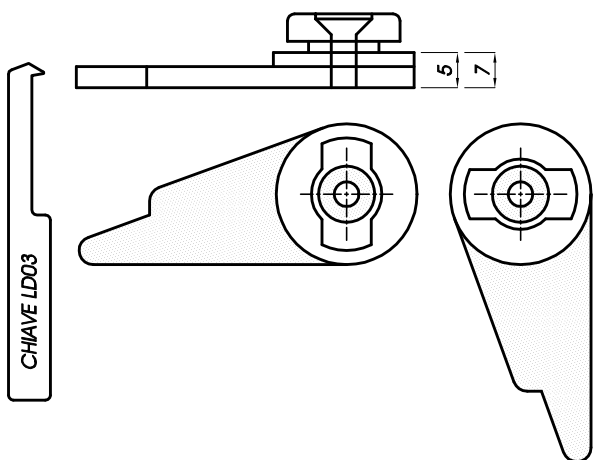

LC5 - Clips girevole con vite 3mm

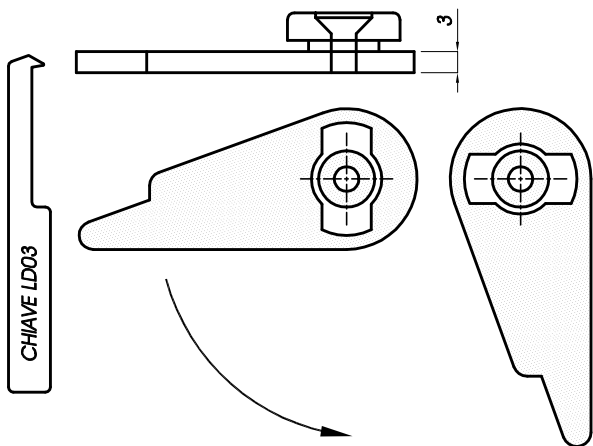

LC26/3 e LC26/5  
 Clips girevole con vite

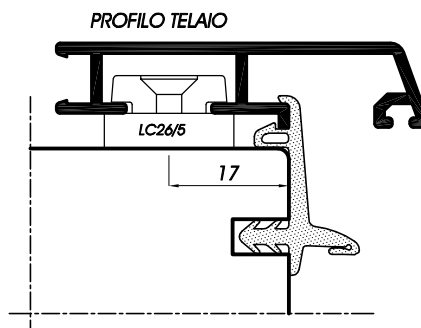
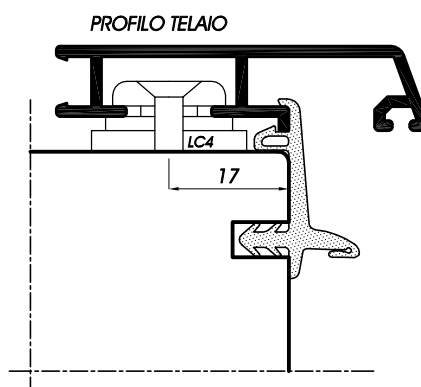
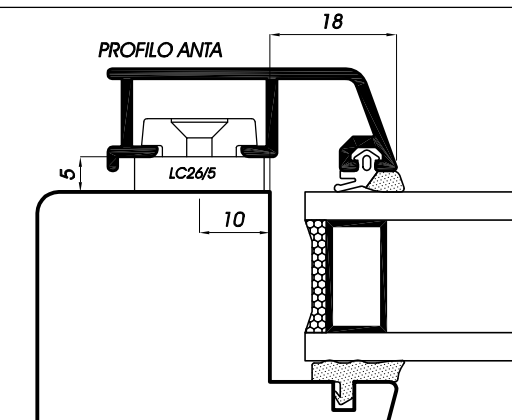
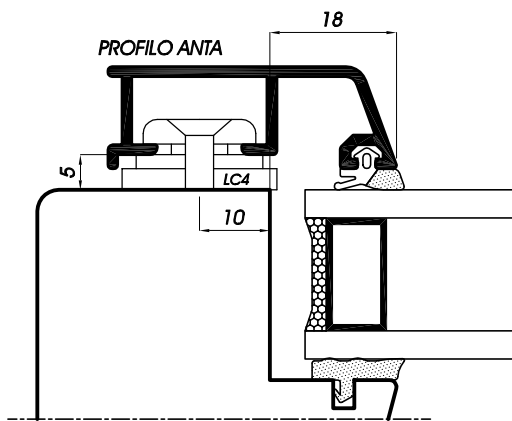
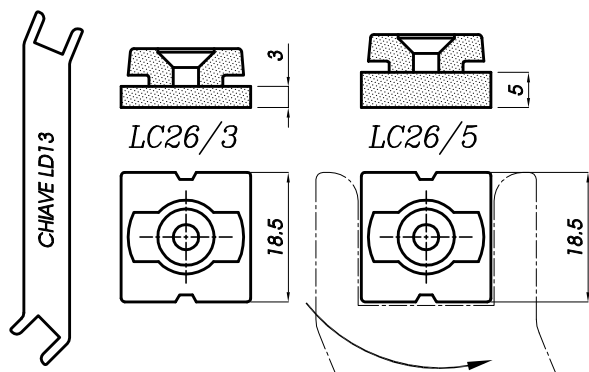

Clips a rotazione con vite  
 Drehhalter mit Schrauben  
 Clips giratorios con tornillo  
 Clips tournants avec vis  
 Turning clips with screw

LC27/3 e LC27/5  
Clips girevole a scatto con vite

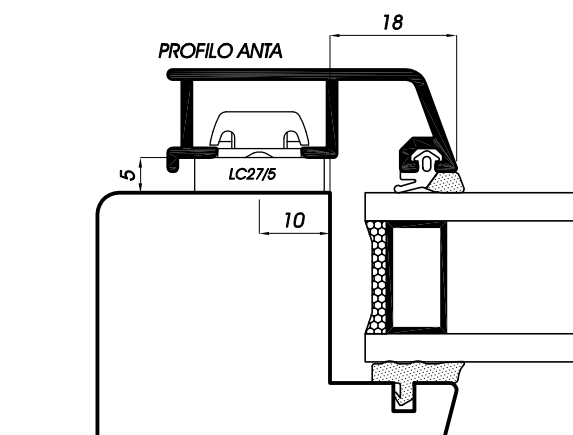
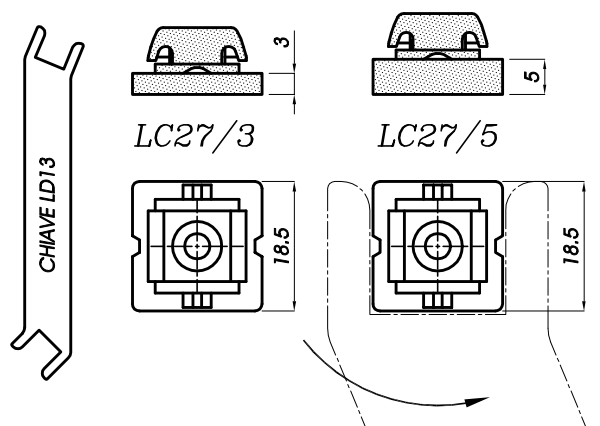

LC18/3 e LC18/5  
Clips girevole a scatto con vite

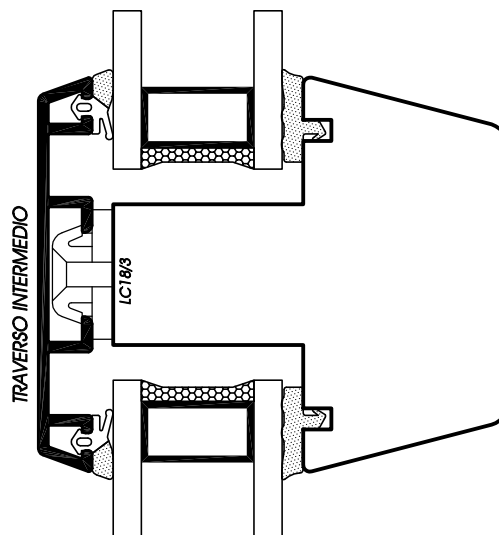
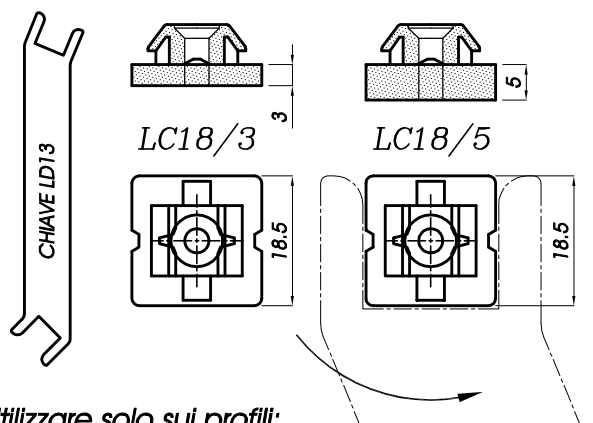

Utilizzare solo sui profili:  
LA201-LA202-LA203-LA205  
LA206-LA223-LA224-LA234-LA235

LC25 - Clips a scatto senza vite  
per profili telaio

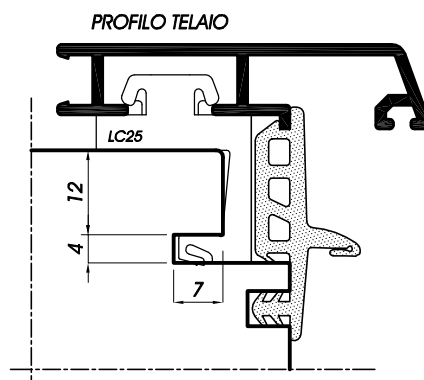
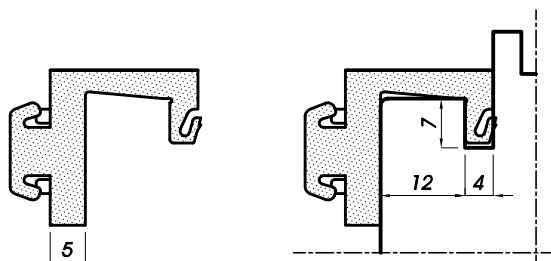

Clips girevole a scatto con vite  
Schlag-Drehklip mit Schrauben  
Clips giratorio de resorte con tornillo  
Clips tournants à pression avec vis  
Pressing and turning clips with screw

LC3 – Clips a scatto senza vite  
per battuta vetro 18mm

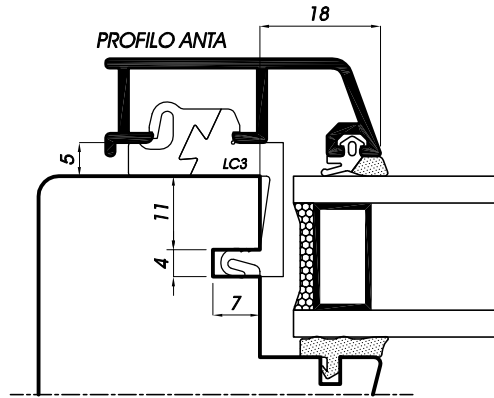
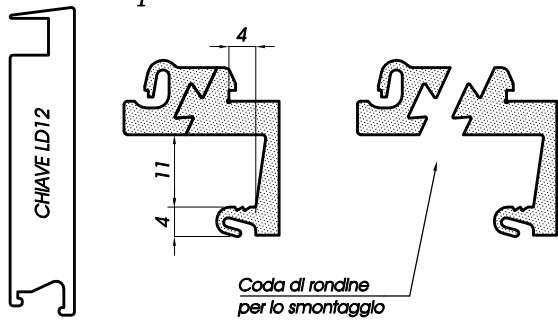

LC24 – Clips a scatto senza vite  
per battuta vetro 20mm

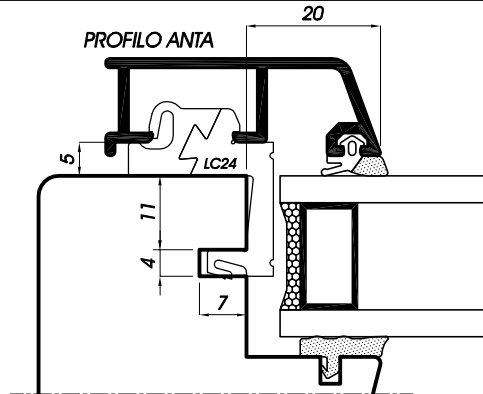
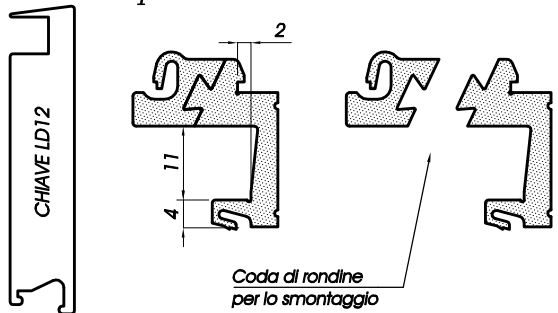

LC31 – Clips a scatto senza vite  
per battuta vetro 20mm

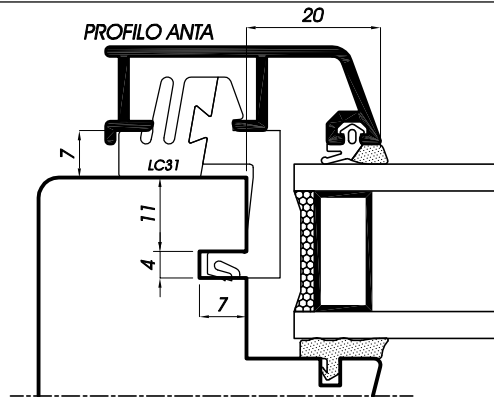
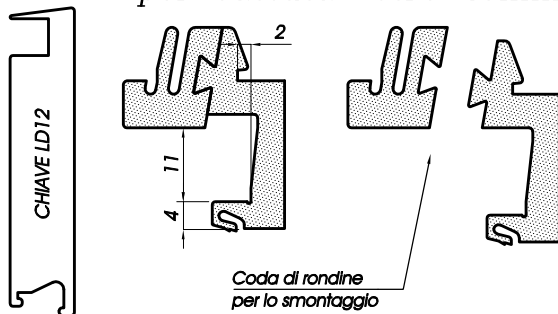

LC13 – Clips a scatto senza vite  
per battuta vetro 20mm

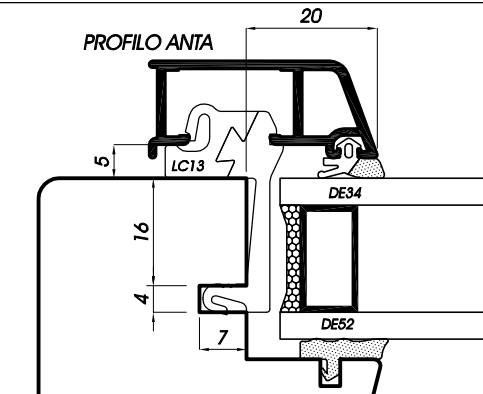
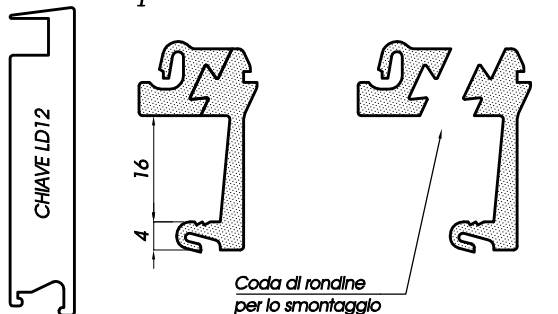

Clips a scatto senza vite  
Clips ohne Schrauben  
Clips de resorte sin tornillo  
Clips à pression sans vis  
Pressing clips without screw

## SMONTAGGIO CLIPS A SCATTO

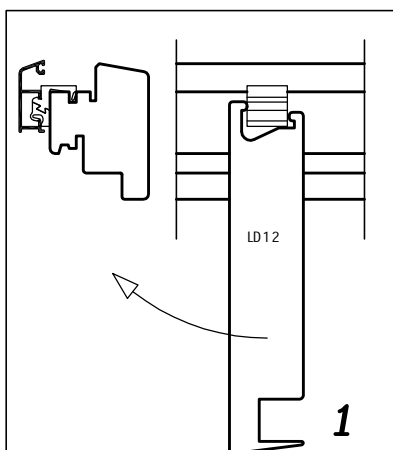

1. Prendere le clips con la chiave LD12 e ruotare verso sinistra (senso orario)

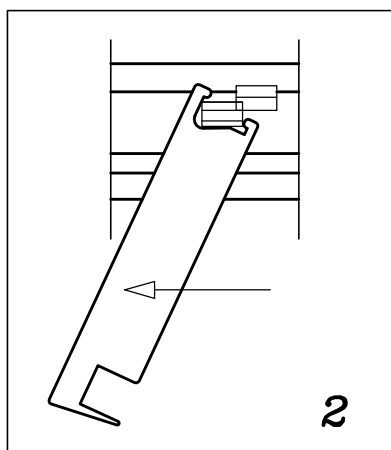

2. Spingere verso sinistra fino a togliere il pezzo sotto delle clips LC3 - LC13 - LC24

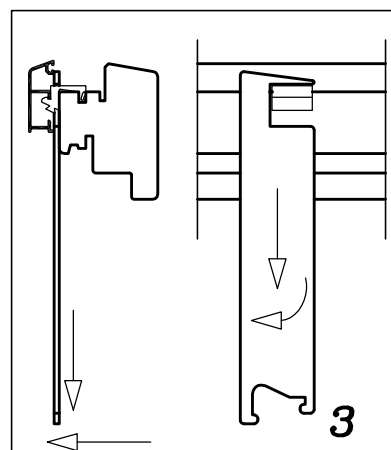

3. Tirare verso l'esterno le clips e sollevare il profilo di alluminio fino a farlo scattare fuori.

## SMONTAGGIO CLIPS LC19 (MODULARE)

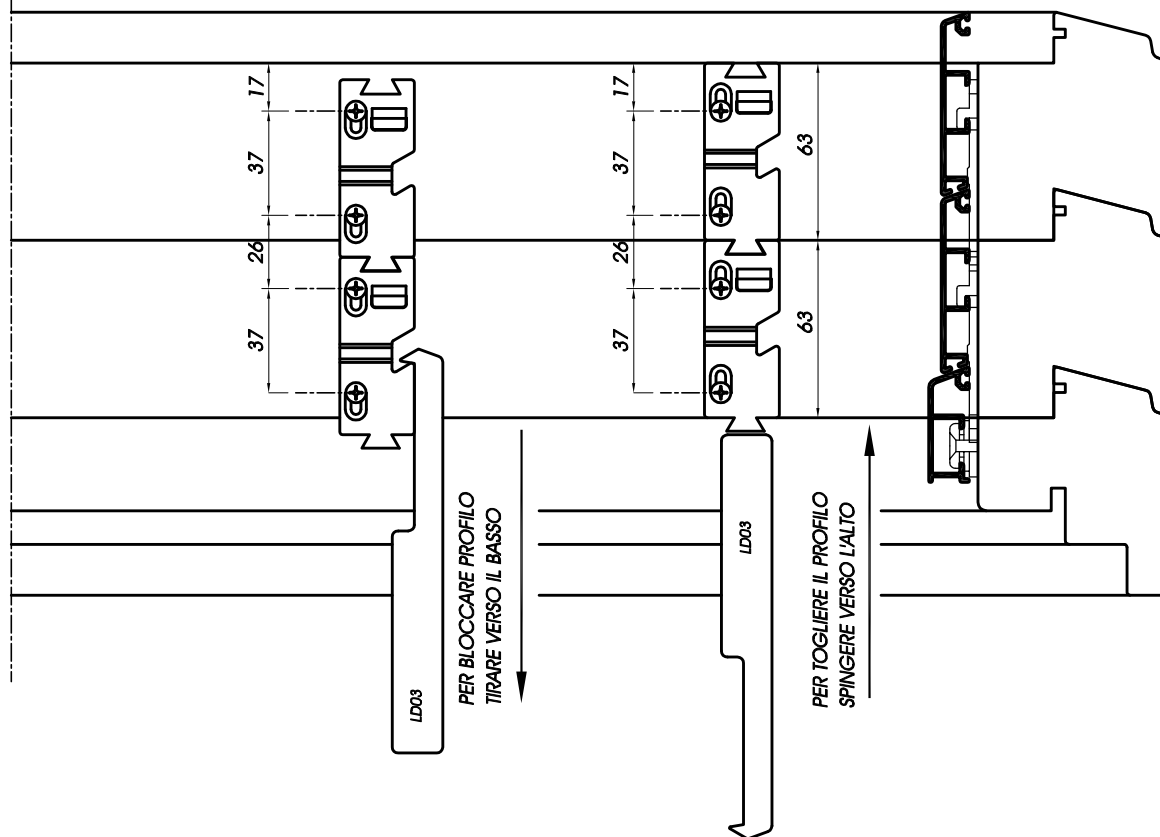

Smontaggio clips  
 Demontage der schraublosen Klips  
 Desmontaje de los clips  
 Demontage clips  
 Disassembly of the clips

*Posizionamento delle clips:*

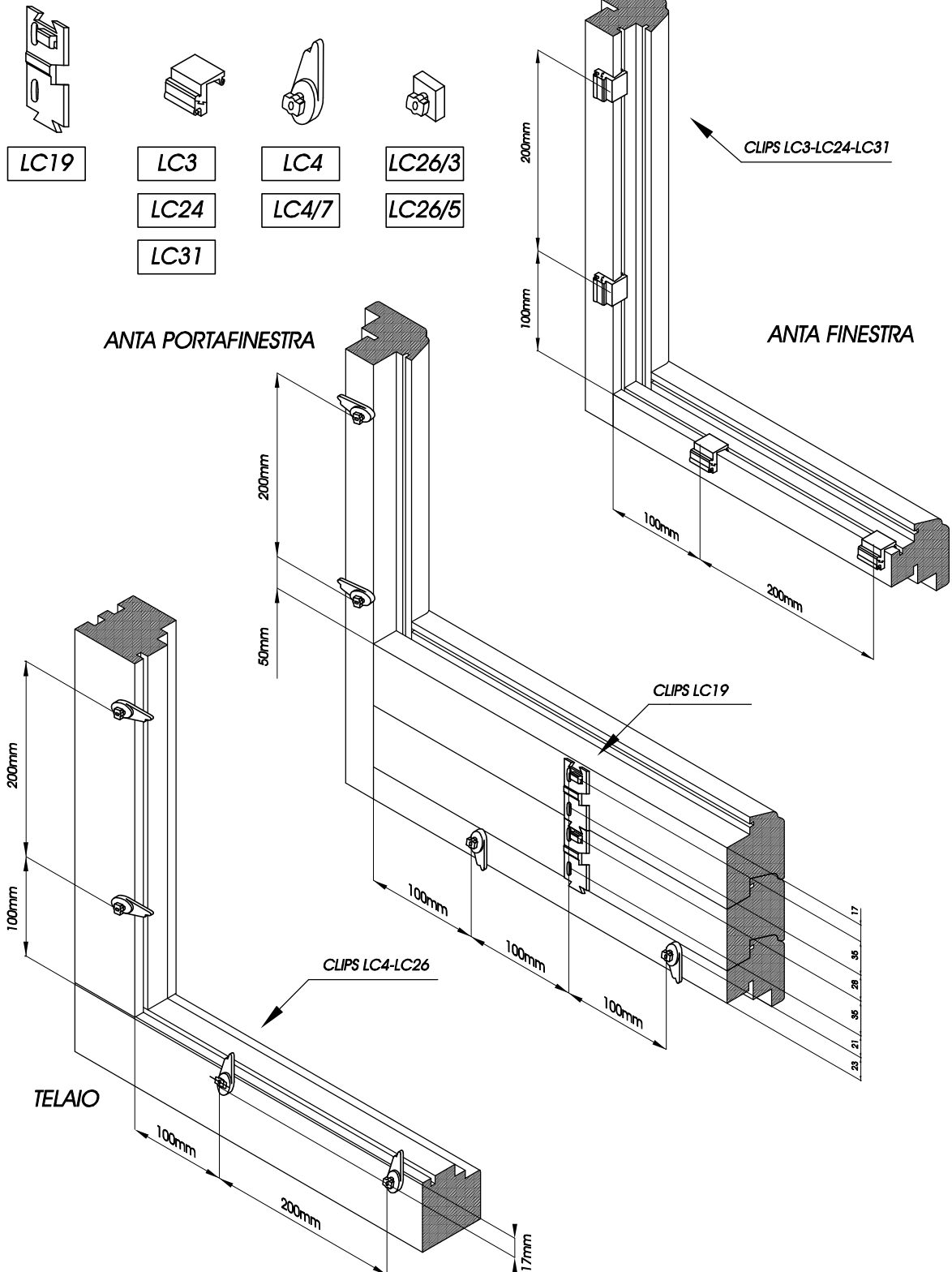

**Schema di posizionamento clips telaio e anta**  
**Montagehinweis der Klips für Rahmen und Flügel**  
**Sistema de montaje de los clips para marco y hoja**  
**Système de positionnement des clips pour le dormant et l'ouvrant**  
**Schema for the positioning of the clips over the frame and the wing**

## LC21 – Blocchetto di rinforzo per portefinestre

LC21 da montare in sostituzione alle clips sul traverso inferiore del telaio con interasse 200mm

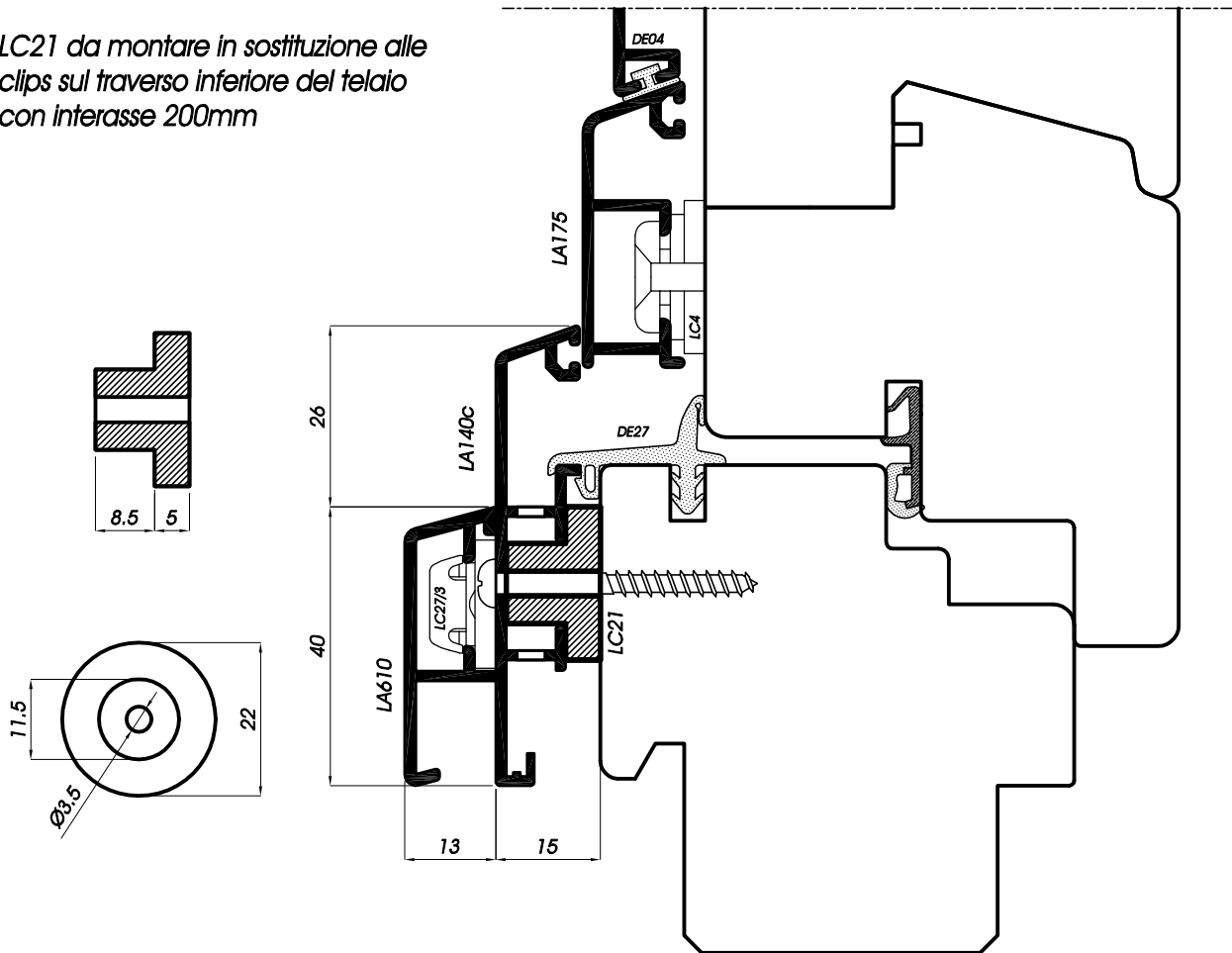

## LC22 – Fermo di sicurezza per bloccaggio del vetro

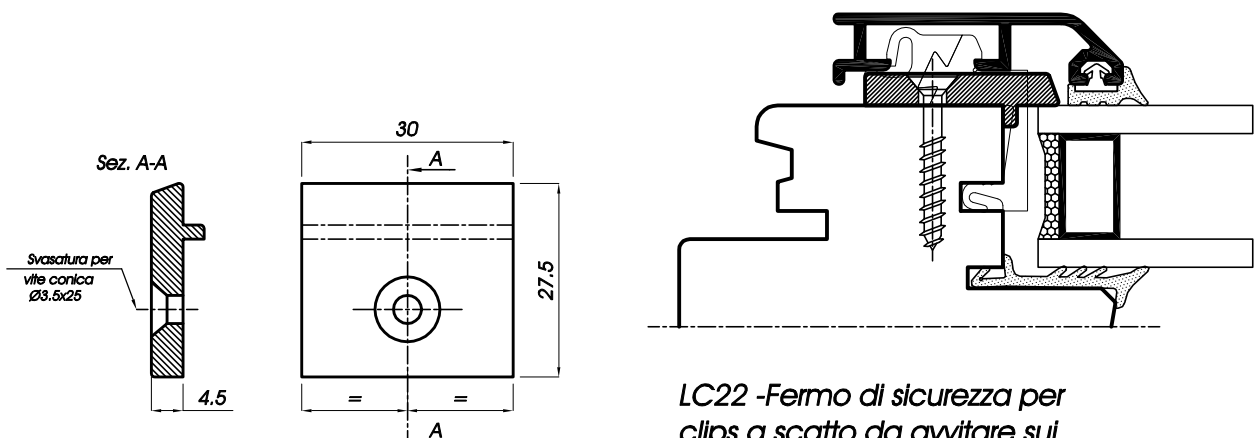

LC22 -Fermo di sicurezza per clips a scatto da avvitare sui montanti dei battenti

Accessori di sicurezza  
 Sicherheitszubehör  
 Accesorios de seguridad  
 Accessoires de sécurité  
 Safety spare-parts

## LC29 – TAPPO DI CHIUSURA PER TRAVERSI TELAIO

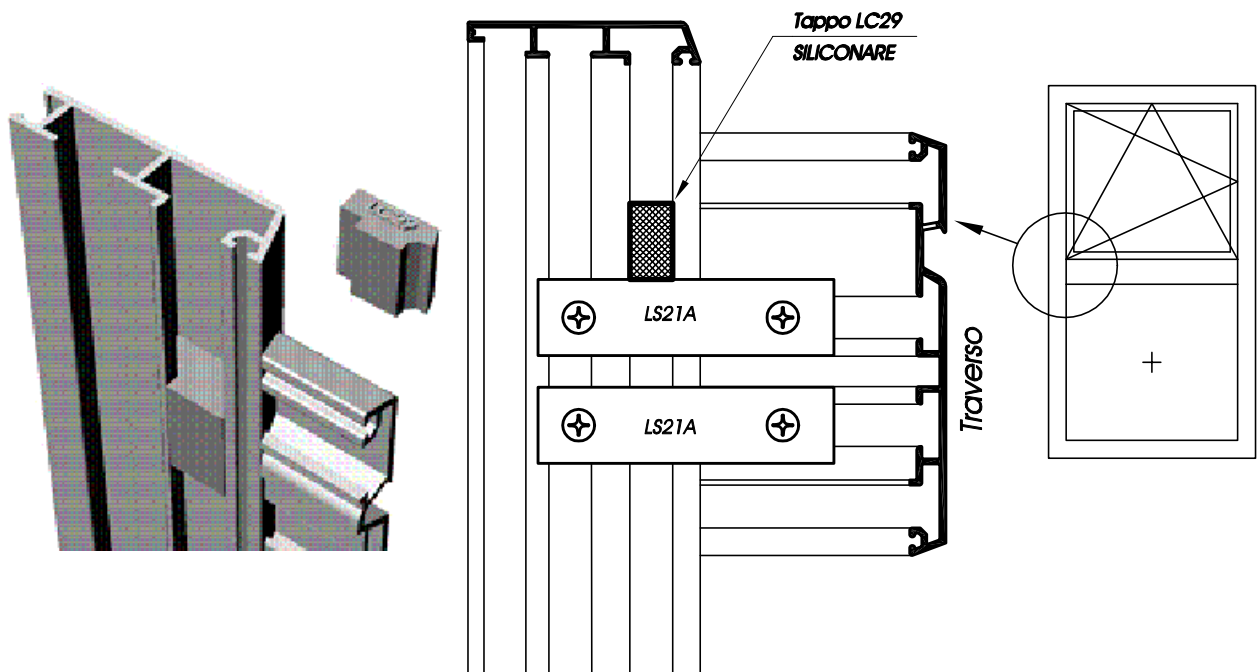

## LS44 – SQUADRETTA DI STABILIZZAZIONE PER FISSI

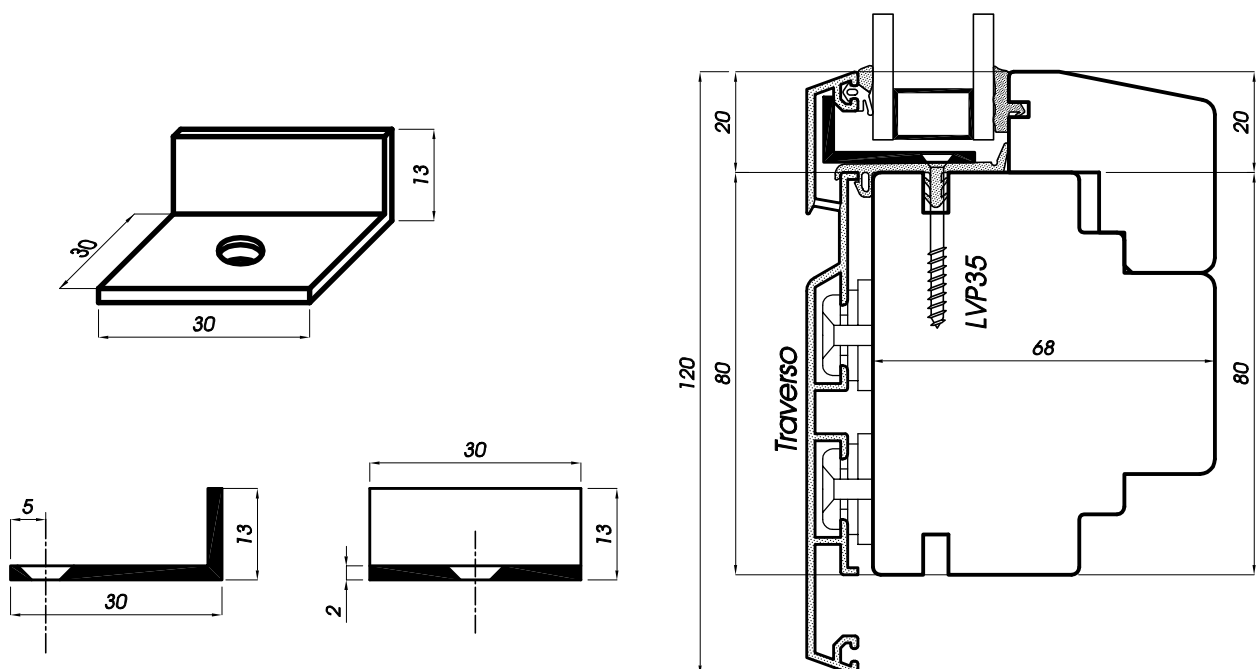

Accessori di sicurezza  
 Sicherheitszubehör  
 Accesorios de seguridad  
 Accessoires de sécurité  
 Safety spare-parts

## GEOMETRIE REALIZZABILI

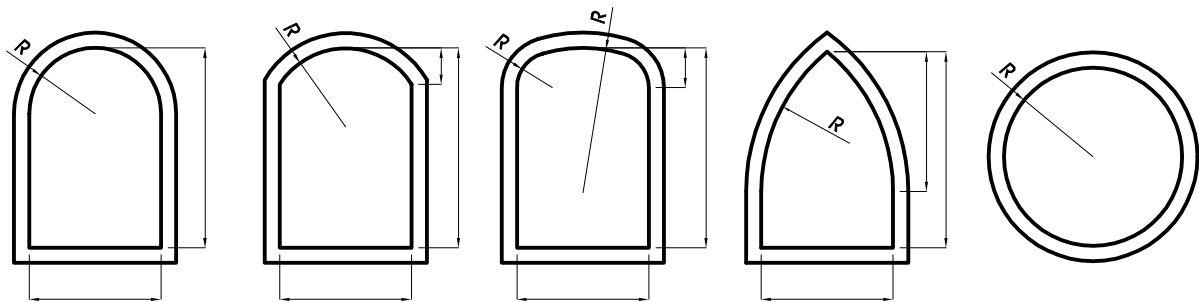

RAGGI MINIMI DI CURVATURA (esterno alluminio grezzo)			
PROFILI ANTA	RAGGIO (ext.)	PROFILI ELAIO	RAGGIO (ext.)
LA175	250 mm	LA149	300 mm
LA176	330 mm	LA140	350 mm
LA189	300 mm	LA141	500 mm
LA253	300 mm	LA285	600 mm
LA241	300 mm	LA230	350 mm
LA227	250 mm	LA232	400 mm
LA248	500 mm	LA233	600 mm
LA228	400 mm	LA282	400 mm
LA229	600 mm	PROFILI INTERMEDI	RAGGIO (ext.)
LA254	500 mm	LA137	250 mm
LA256	400 mm	LA198	250 mm

I PROFILI NON CONTRASSEGNIATI SONO DA FARE SU ORDINAZIONE

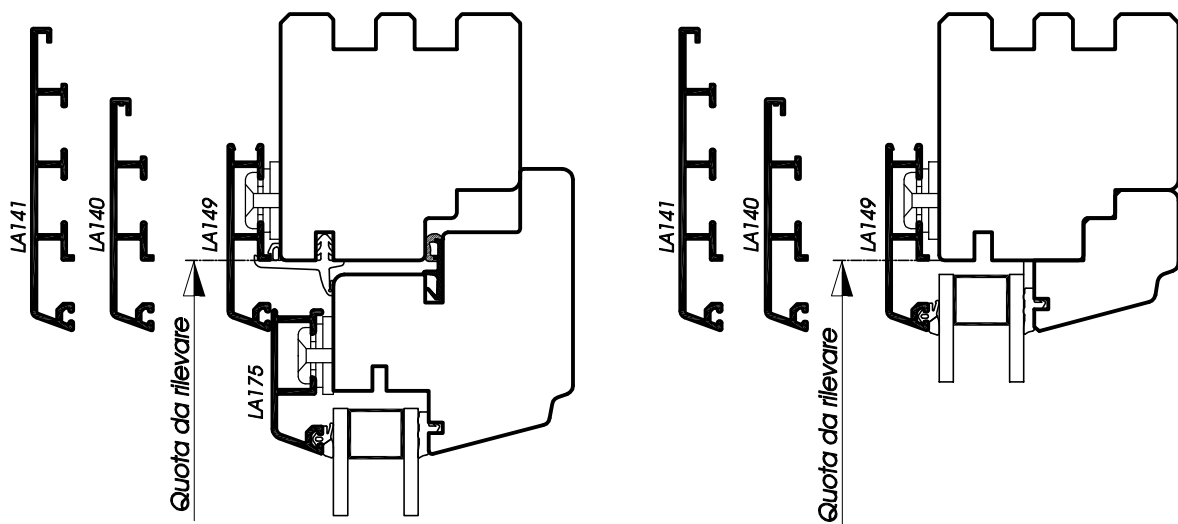

Sezione verticale di riferimento per la rilevazione dei raggi di curvatura  
 Vertikalschnitt zur Berechnung der Radien  
 Sección vertical de referencia para medir los radios de curvatura del aluminio  
 Coupe verticale de référence pour mesurer les rayons du cintre  
 Datum vertical section for the measurement of the sweep's radius





<b>ORDINE</b>	<b>CLIENTE :</b>	<b>RIFERIMENTO ORDINE :</b>	<b>UNIFORM</b>
			SISTEMI PER SERRAMENTI
			PAGG. \ TOT. <b>1</b> \

TELAI SALDATI    
 TELAI ASSEMBLATI MECCANICAMENTE    
 BARRE    
 COLORE

ACCESSORI: BARRARE SE DA NON FORNIRE

TIPO	CLIPS	GUARN.
TELAIO		
ANTA		
CHIUSURA CENTRALE		

**NOTE:**

---

---

---

---

---

---

---

---

---

---

**ATTENZIONE**  
 TUTTE LE QUOTE SONO RIFERITE ALLE MISURE INTERNE DEL LEGNO

SISTEMA PERSONALIZZATO   
 CODICE DISEGNO UNIFORM

## INFORMAZIONI LEGNO

### SEZIONE STANDARD

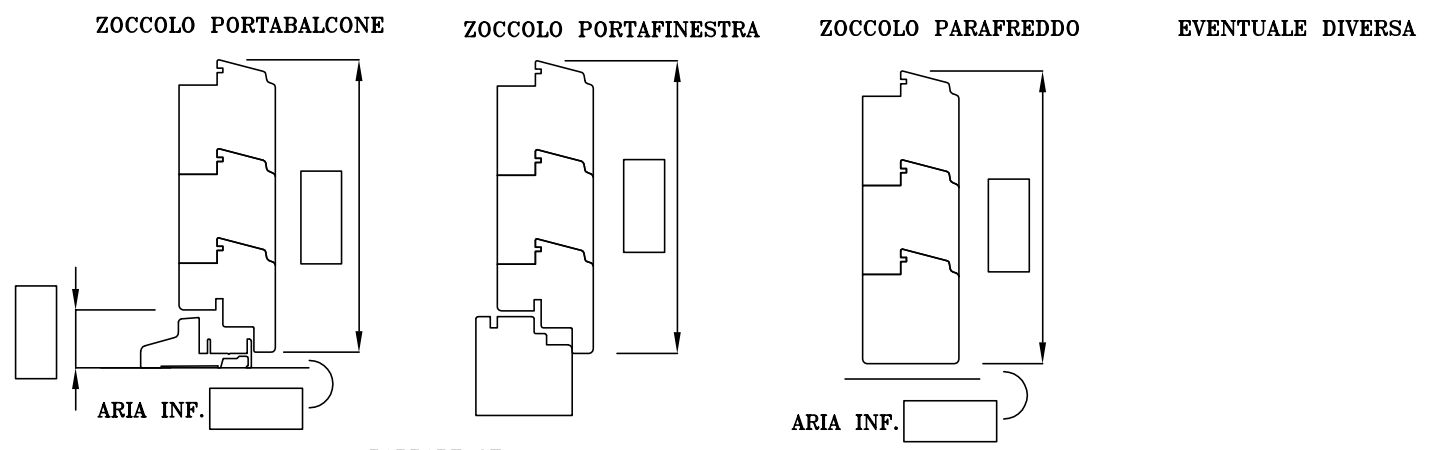
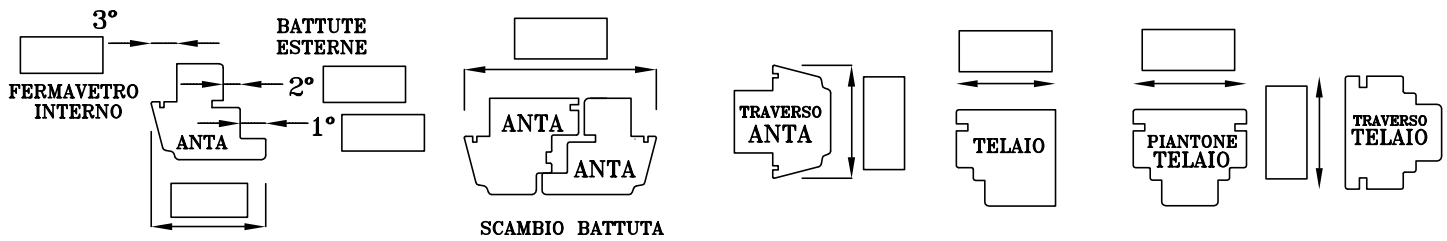

TIPO SOGLIA    
 BARRARE SE DA FORNIRE    
 COLORE

**NB : Qualsiasi sezione non standard deve essere indicata ed evidenziata nell'ordine**



*Sistema*

*ERMETIC 5000/S*

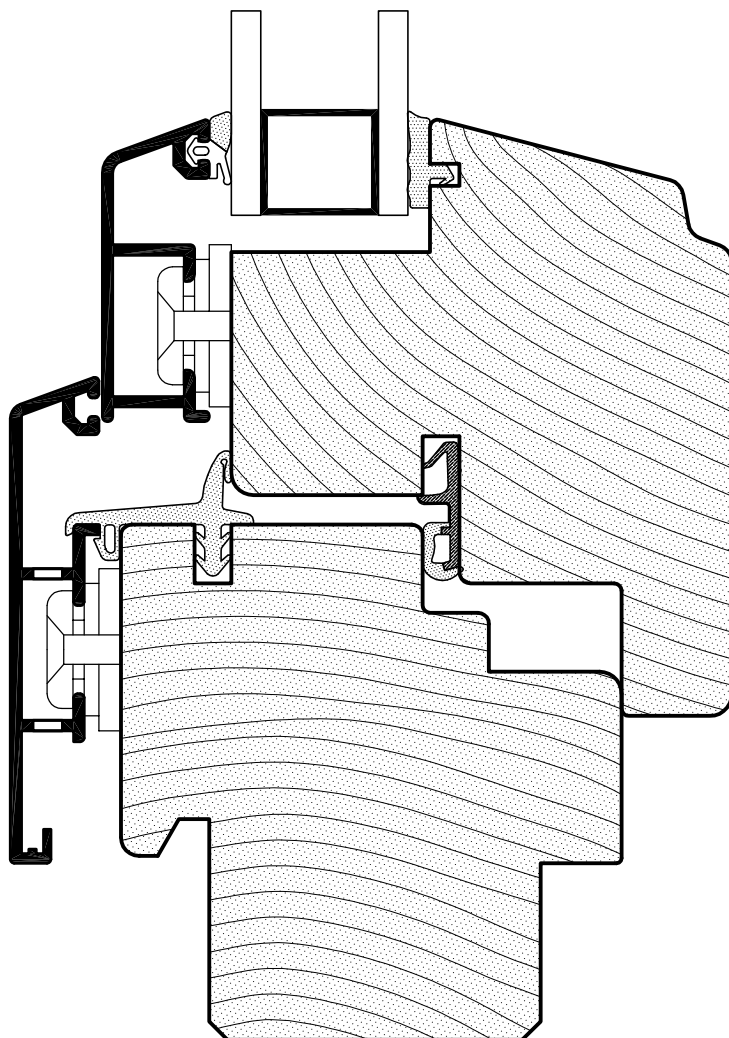

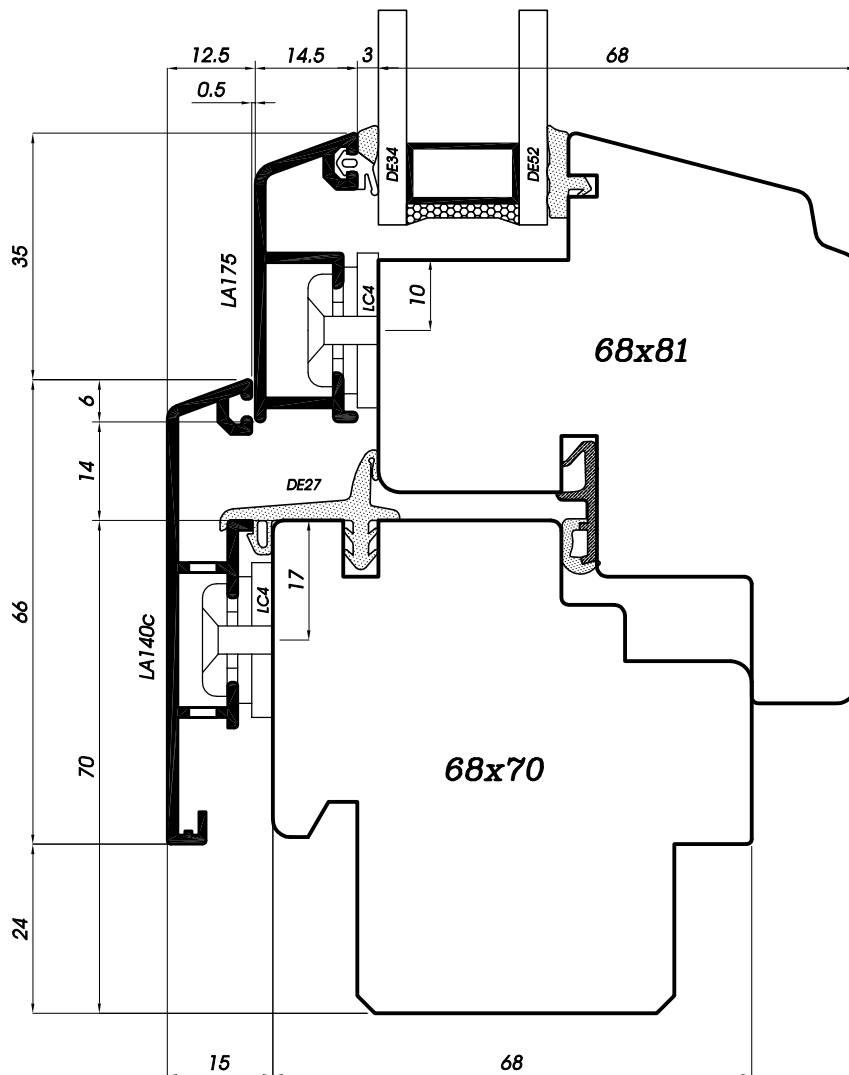
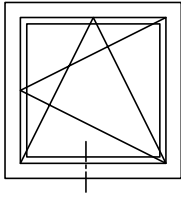

**Sezione verticale traverso inferiore finestra**  
**Vertikalschnitt Fenster quer unten**  
**Sección vertical travesaño inferior de la ventana**  
**Coupe verticale traverse inférieure fenêtre**  
**Vertical section of the window's lower ledge**

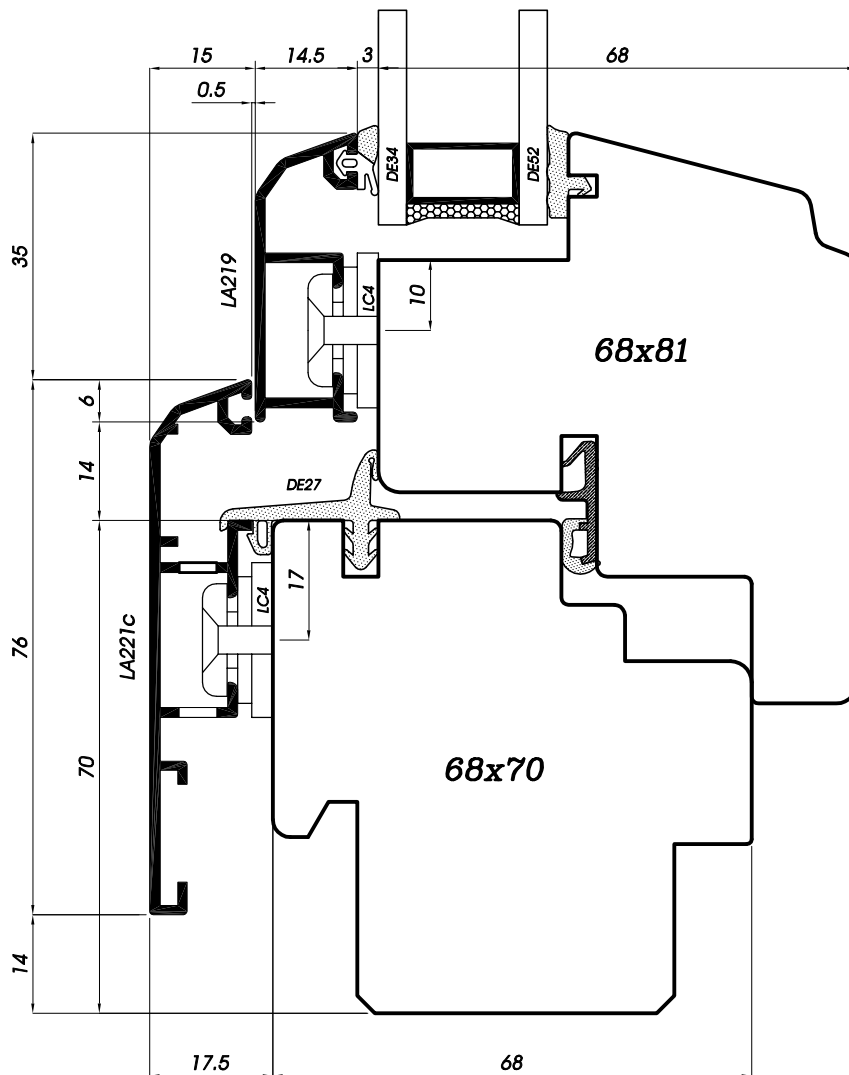
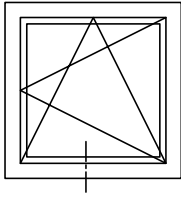

**Sezione verticale traverso inferiore finestra**  
**Vertikalschnitt Fenster quer unten**  
**Sección vertical travesaño inferior de la ventana**  
**Coupe verticale traverse inférieure fenêtre**  
**Vertical section of the window's lower ledger**

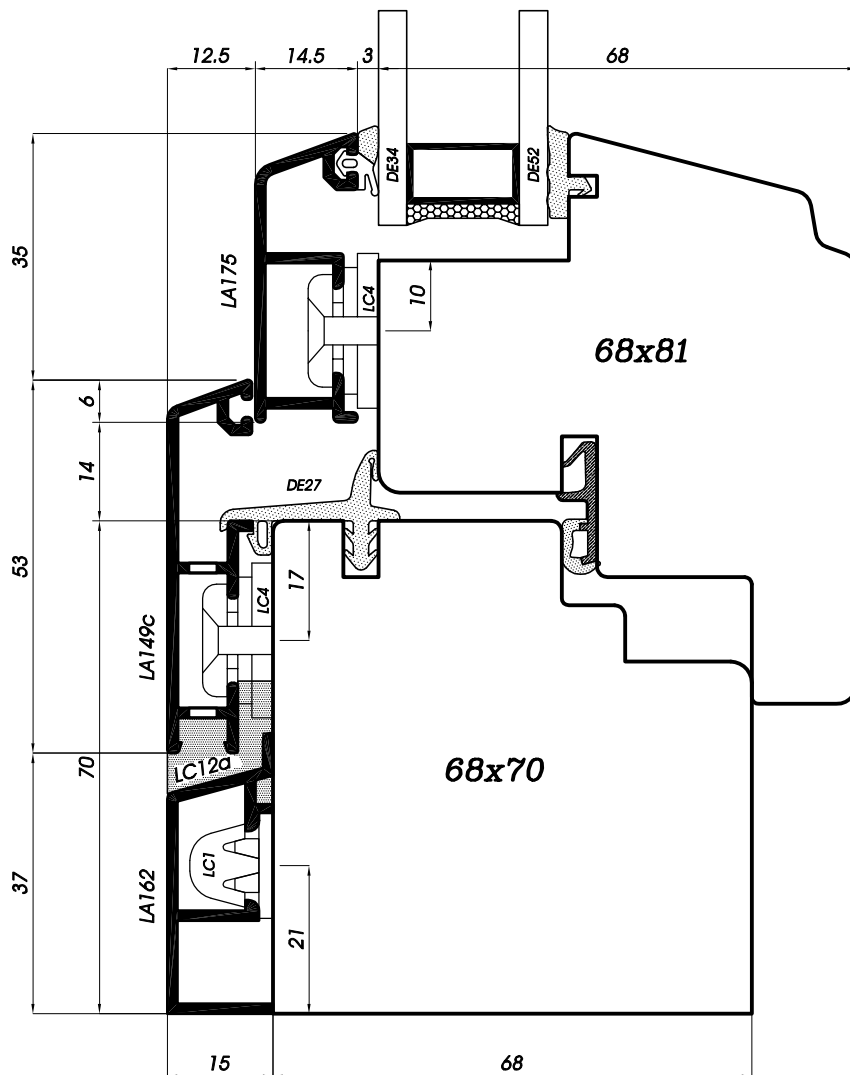
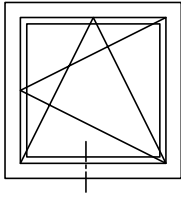

**Sezione verticale traverso inferiore finestra**  
**Vertikalschnitt Fenster quer unten**  
**Sección vertical travesaño inferior de la ventana**  
**Coupe verticale traverse inférieure fenêtre**  
**Vertical section of the window's lower ledger**

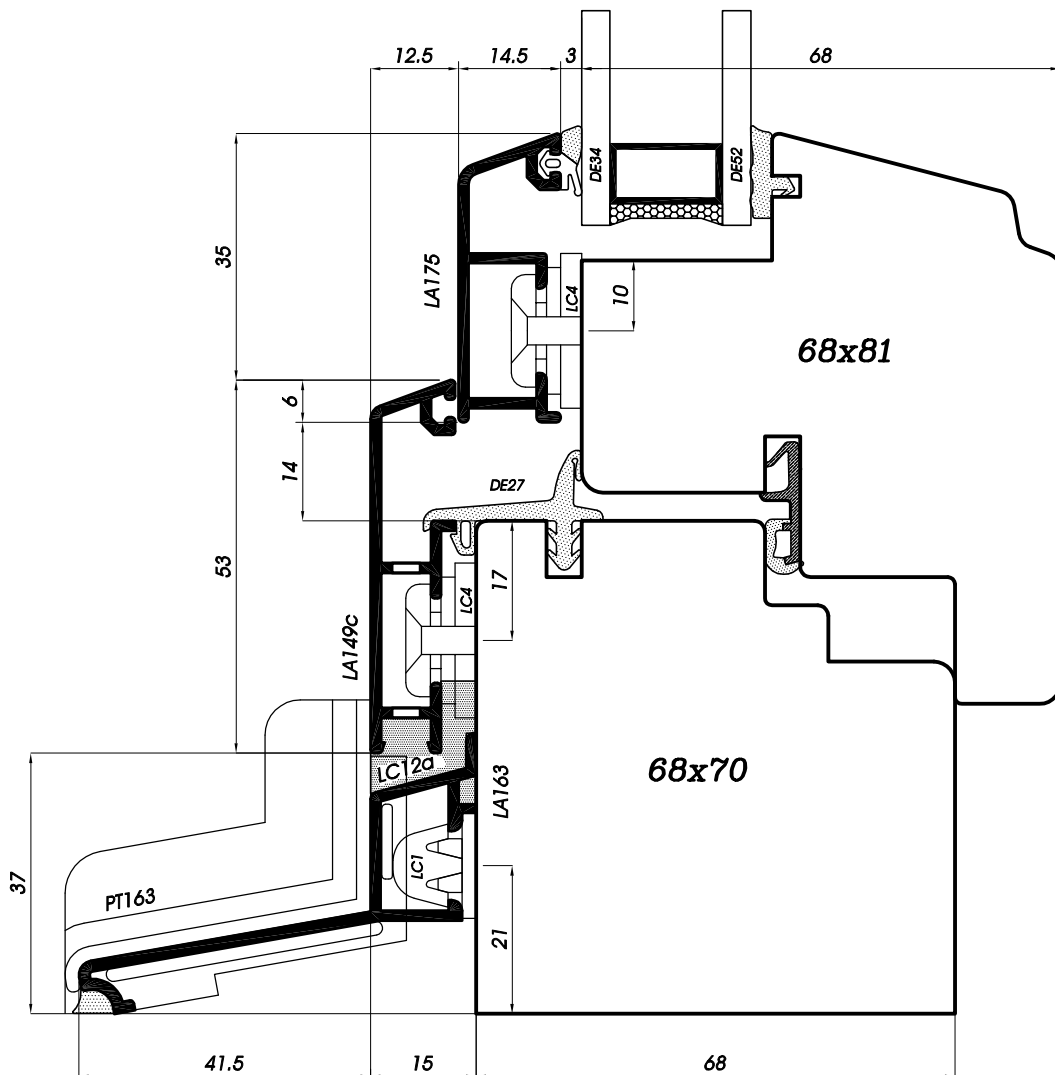
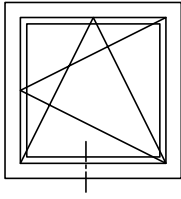

**Sezione verticale traverso inferiore finestra**  
**Vertikalschnitt Fenster quer unten**  
**Sección vertical travesaño inferior del marco**  
**Coupe verticale traverse inférieure fenêtre**  
**Vertical section of the window's lower ledger**



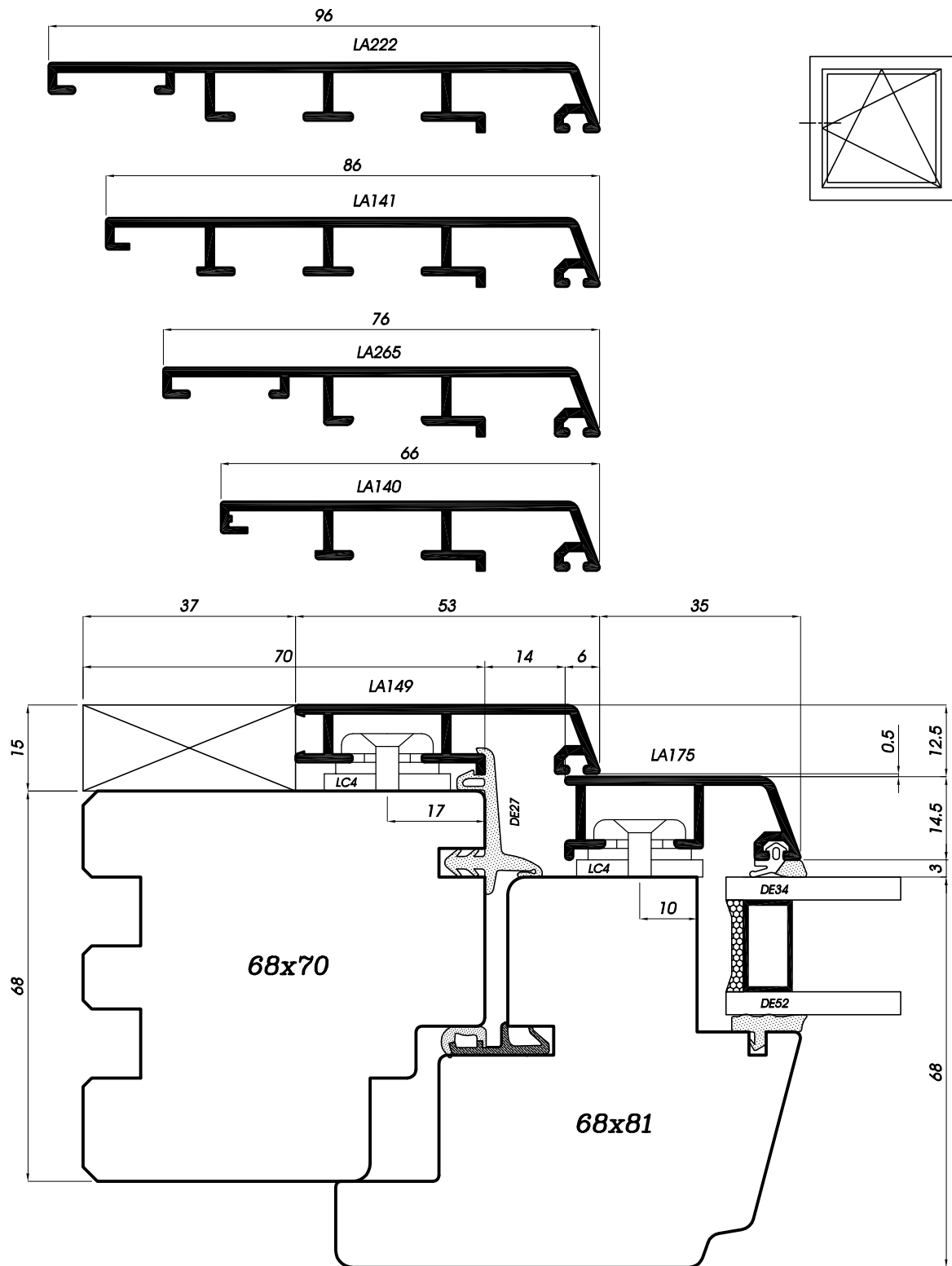

Sezione orizzontale montanti laterali  
 Horizontalschnitt senkrecht seitlich  
 Sección horizontal de montantes laterales  
 Coupe horizontale montants latéraux  
 Horizontal section of the lateral jambs

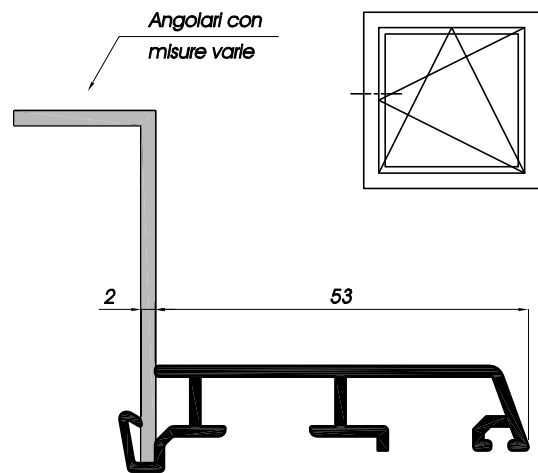
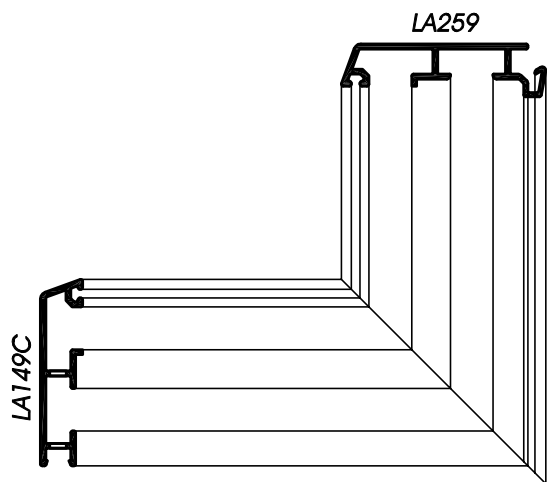

Nuovo profilo - LA259

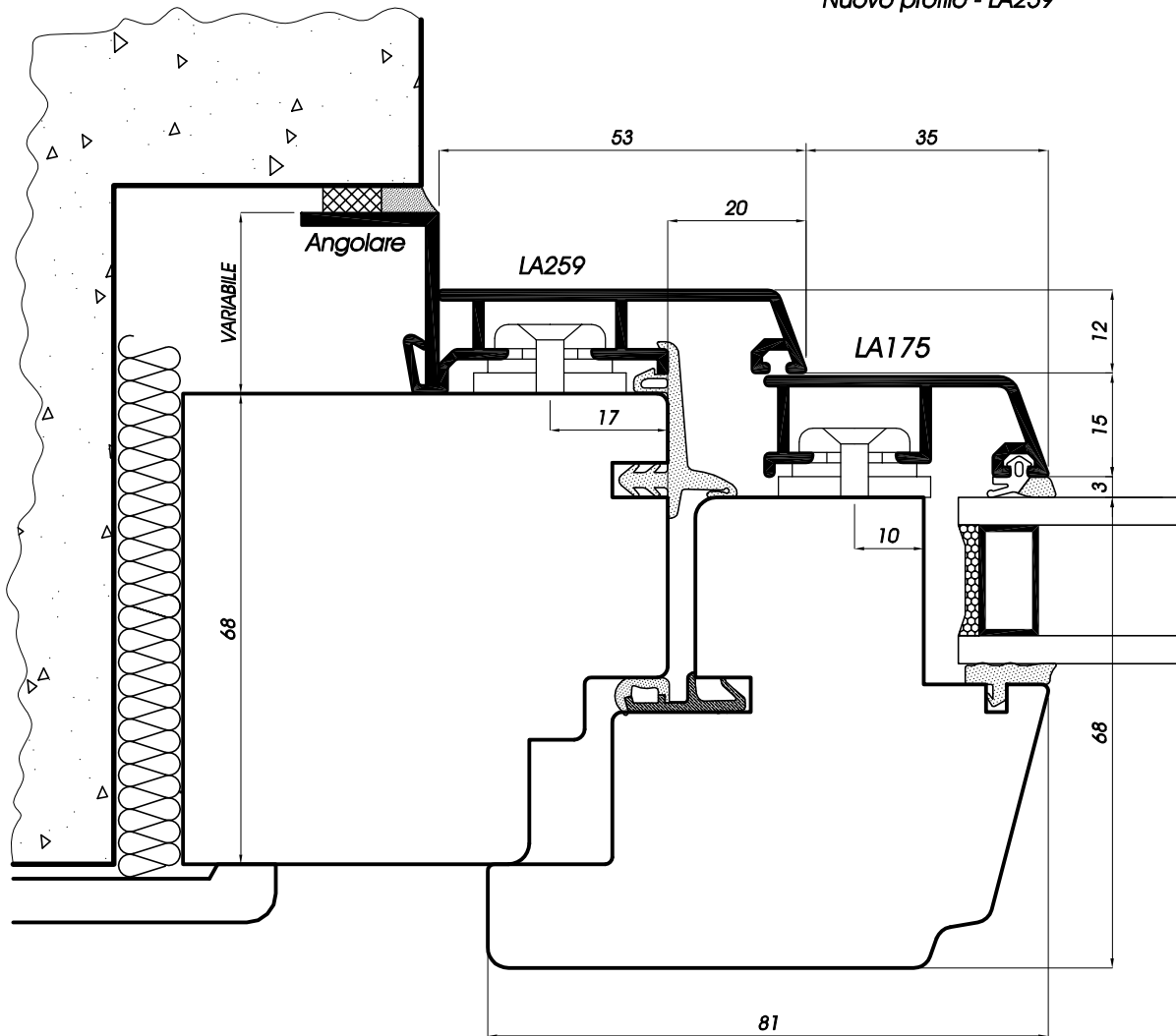

Sezione orizzontale montanti laterali per la ristrutturazione  
 Horizontalschnitt senkrecht seitlich für Sanierung  
 Sección horizontal de montantes laterales para la rehabilitación  
 Coupe horizontale montants latéraux pour la rénovation  
 Horizontal section of the lateral jambs for redevelopment

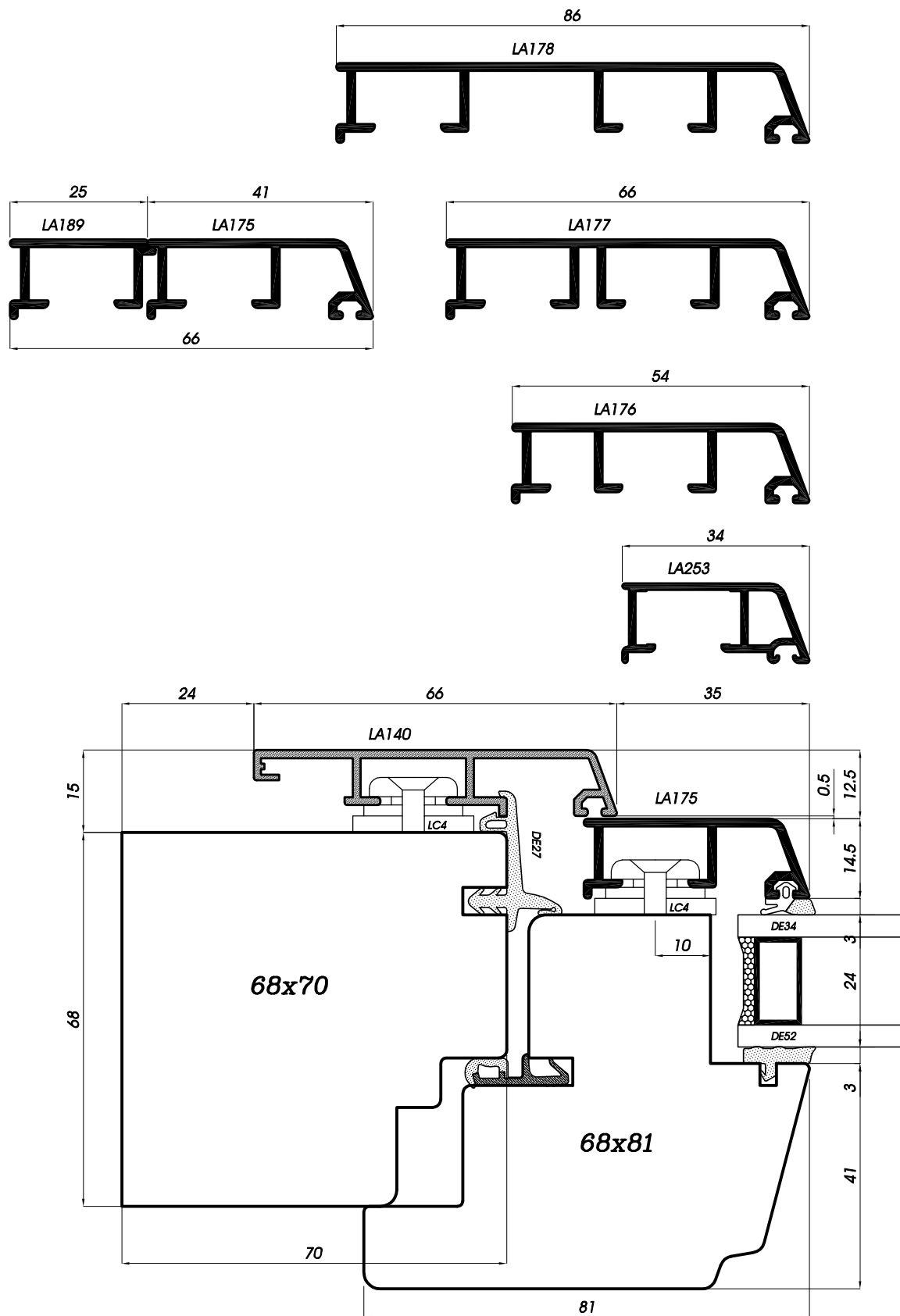

Sezioni orizzontali battenti  
 Horizontalschnitt Flügel  
 Secciones horizontales hojas  
 Coupes horizontales vantaux  
 Horizontal section of the wings

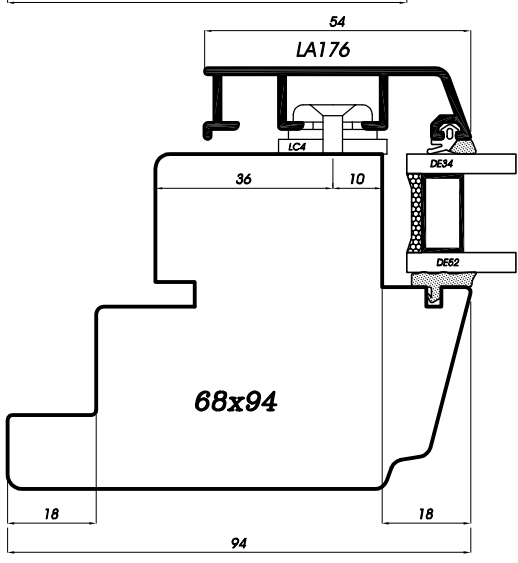
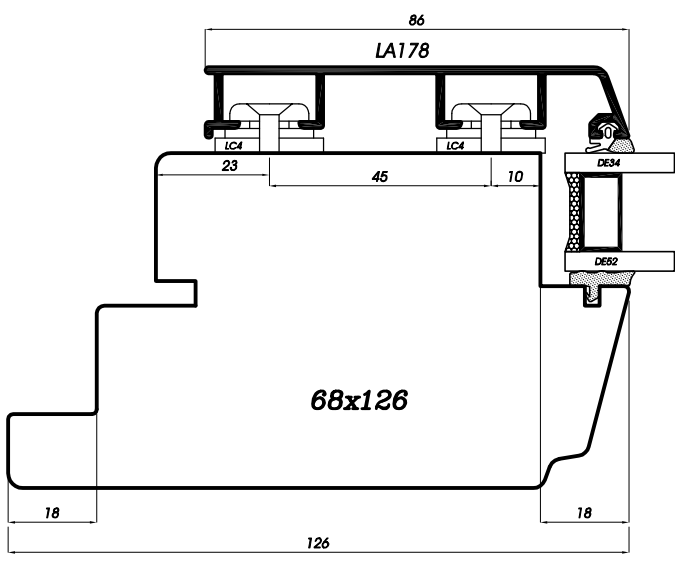
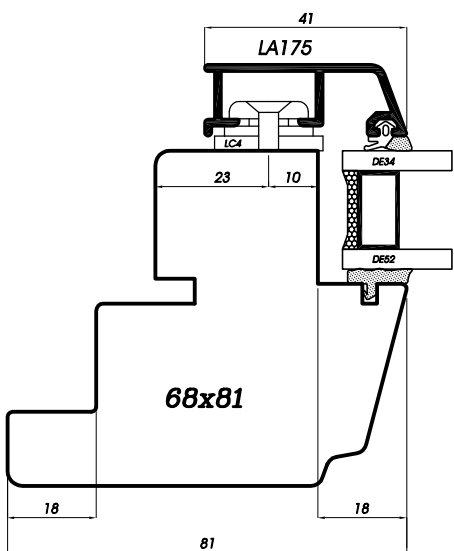
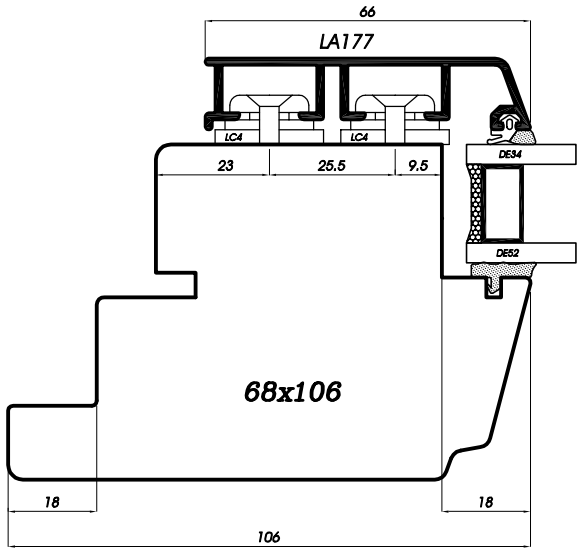
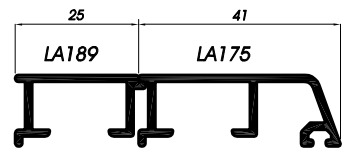
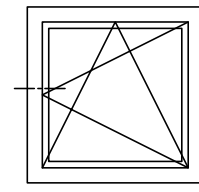
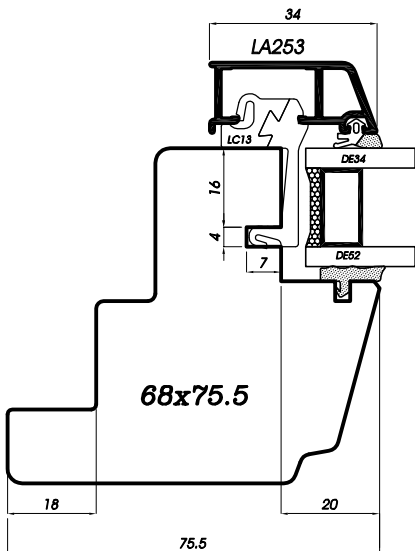

Sezioni orizzontali battenti  
 Horizontalschnitt Flügel  
 Secciones horizontales hojas  
 Coupes horizontales vantaux  
 Horizontal section of the wings

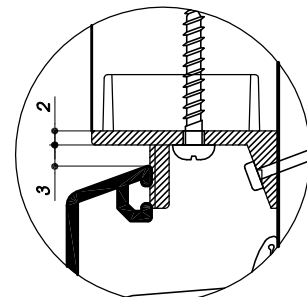
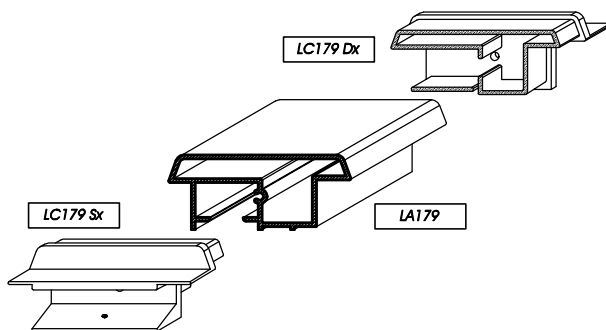
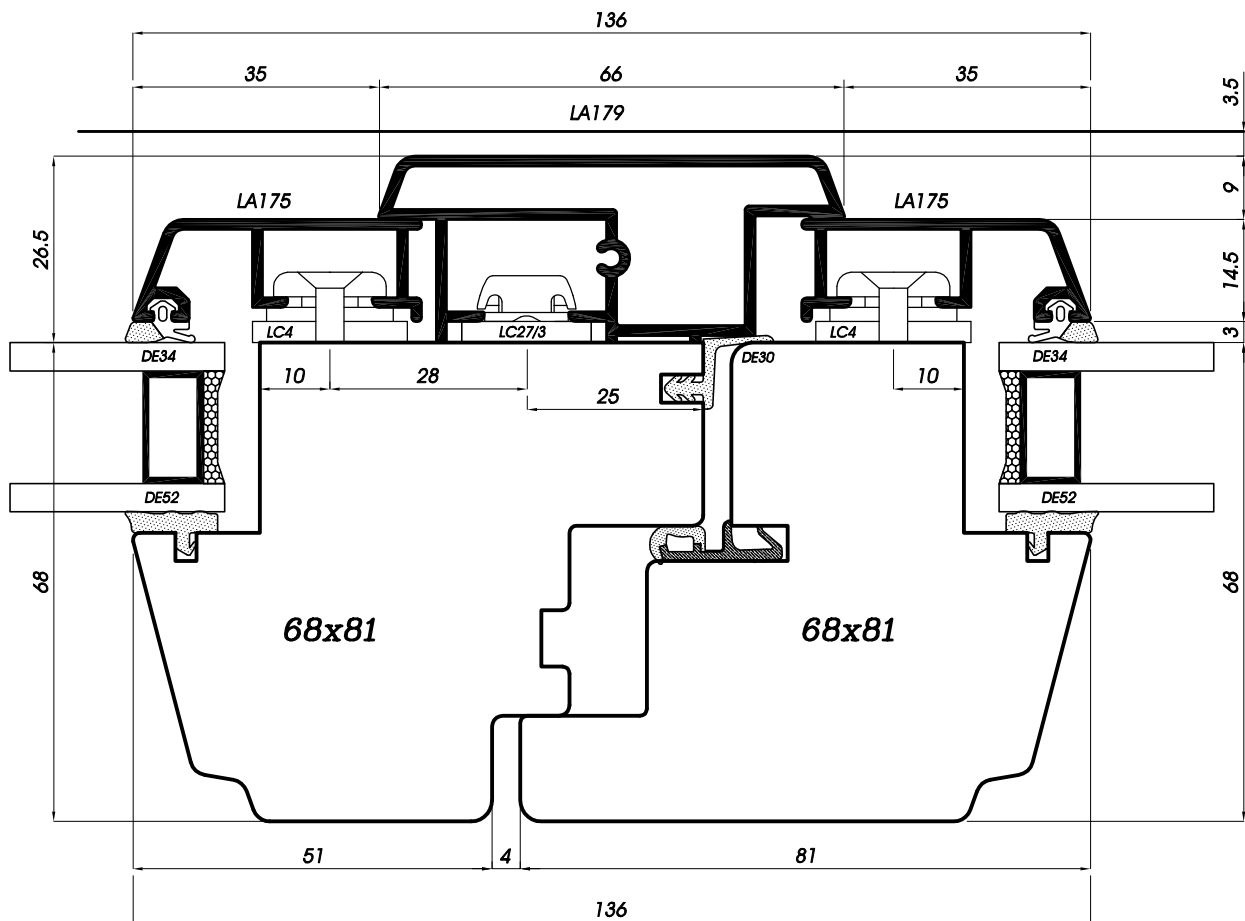
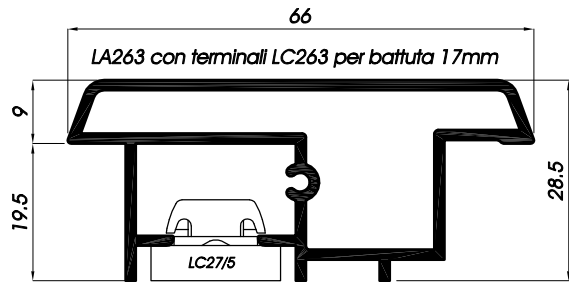
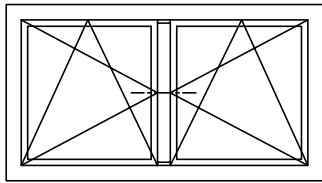

LC179 Dx-Sx

Sezione orizzontale chiusura centrale con profilo LA179 - LA263  
 Horizontalschnitt Stulpprofil LA179 - LA263  
 Sección horizontal del cierre central con perfil LA179 - LA263  
 Coupe horizontale battement central avec profil LA179 - LA263  
 Horizontal section of the middle clamp with profil LA179-LA263

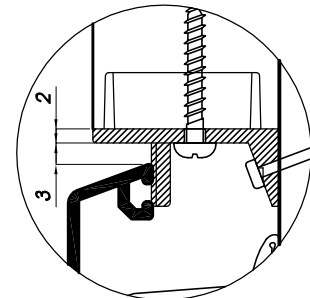
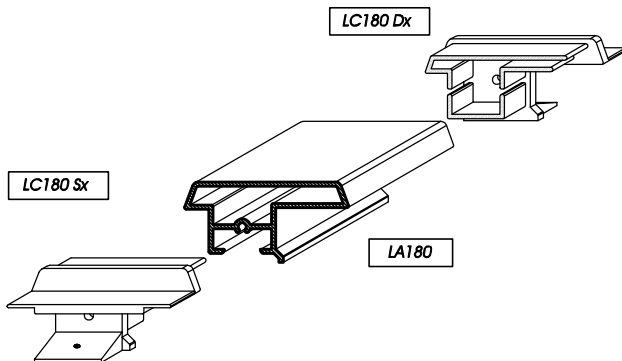
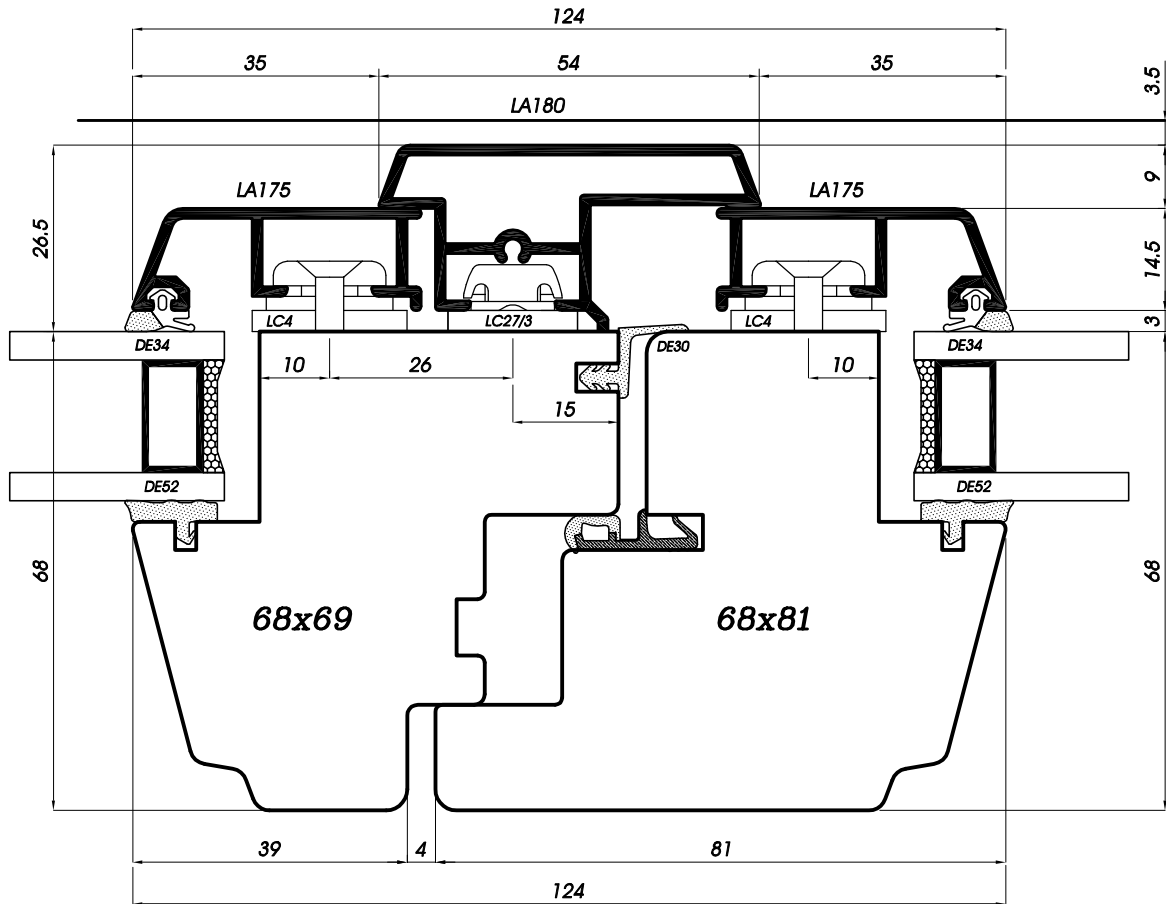
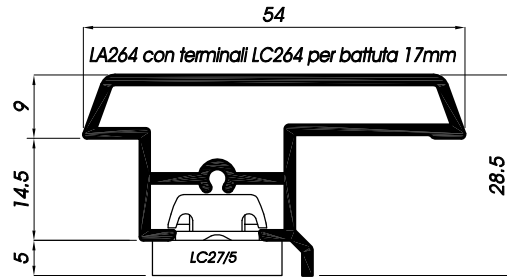
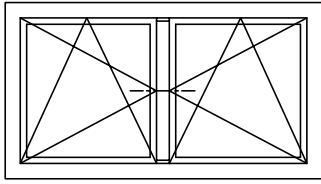

LC180 Dx-Sx

Sezione orizzontale chiusura centrale con profilo LA180 - LA264  
 Horizontalschnitt Stulpprofil LA180 - LA264  
 Sección horizontal del cierre central con perfil LA180 - LA264  
 Coupe horizontale battement central avec profil LA180 - LA264  
 Horizontal section of the middle clamp with profil LA180-LA264

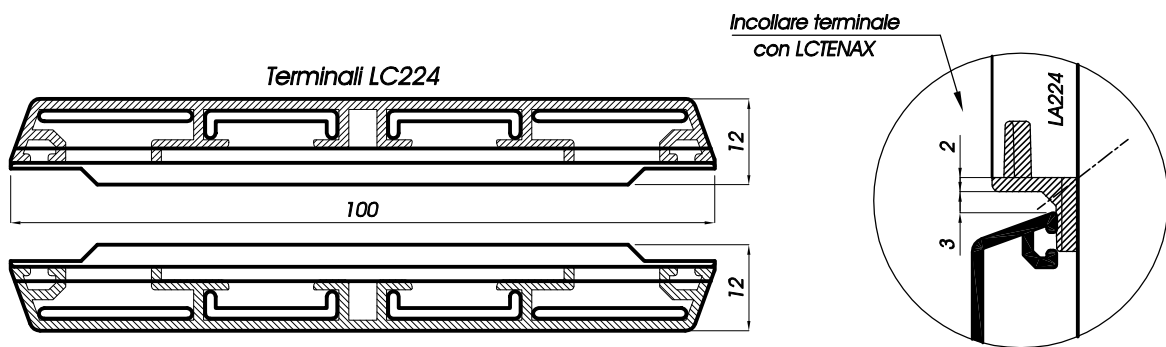
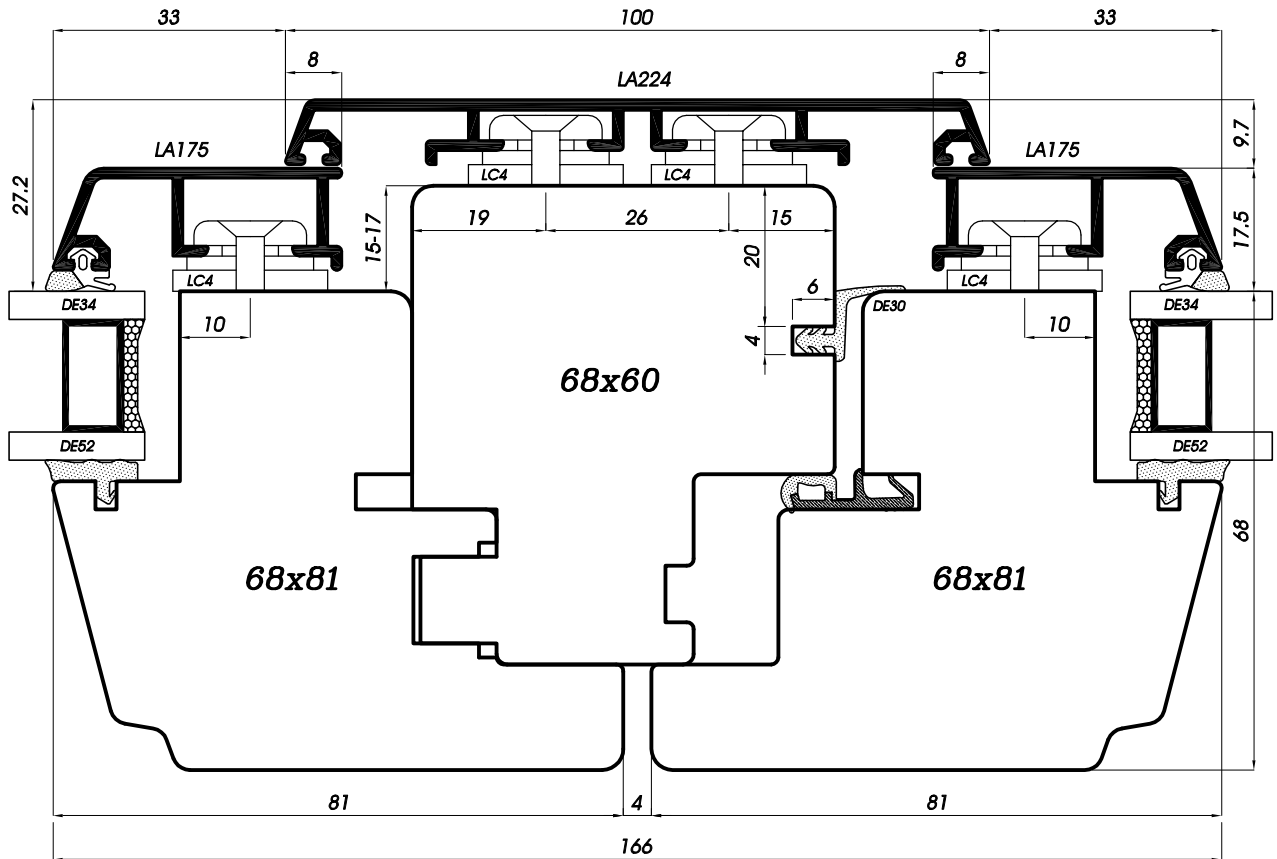
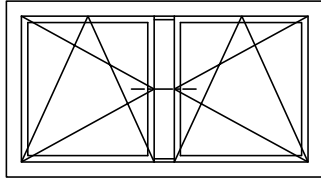

**Sezione orizzontale chiusura centrale con profilo LA224**  
**Horizontalschnitt Stulpprofil LA224**  
**Sección horizontal del cierre central con perfil LA224**  
**Coupe horizontale battement central avec profil LA224**  
**Horizontal section of the middle clamp with profil LA224**

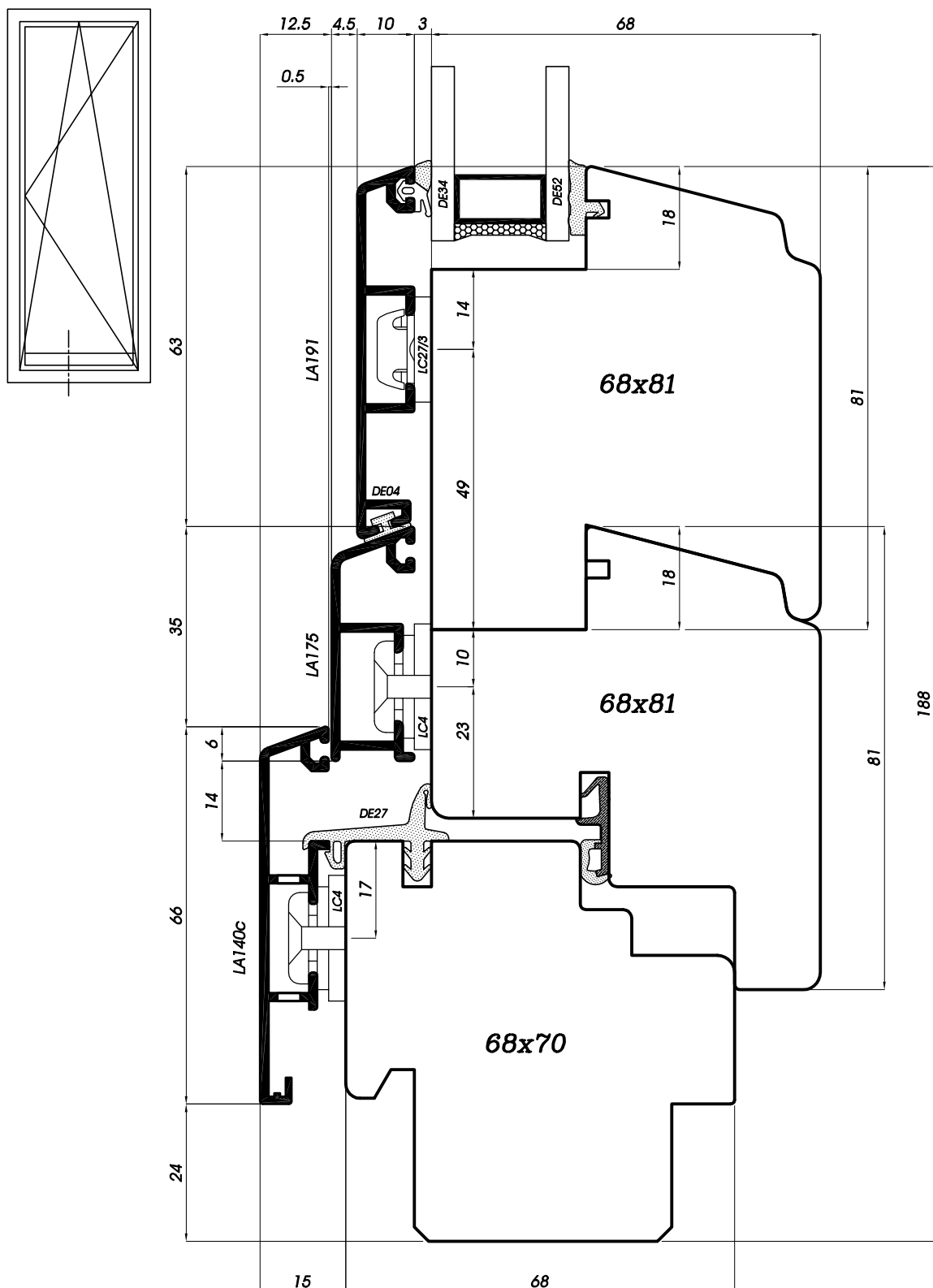

**Sezione verticale traverso inferiore portafinestra**  
**Vertikalschnitt Balkontür quer unten**  
**Sección vertical travesaño inferior puertaventana**  
**Section verticale traverse inférieure porte-fenêtre**  
**Vertical section of the window's lower ledger for window-door**



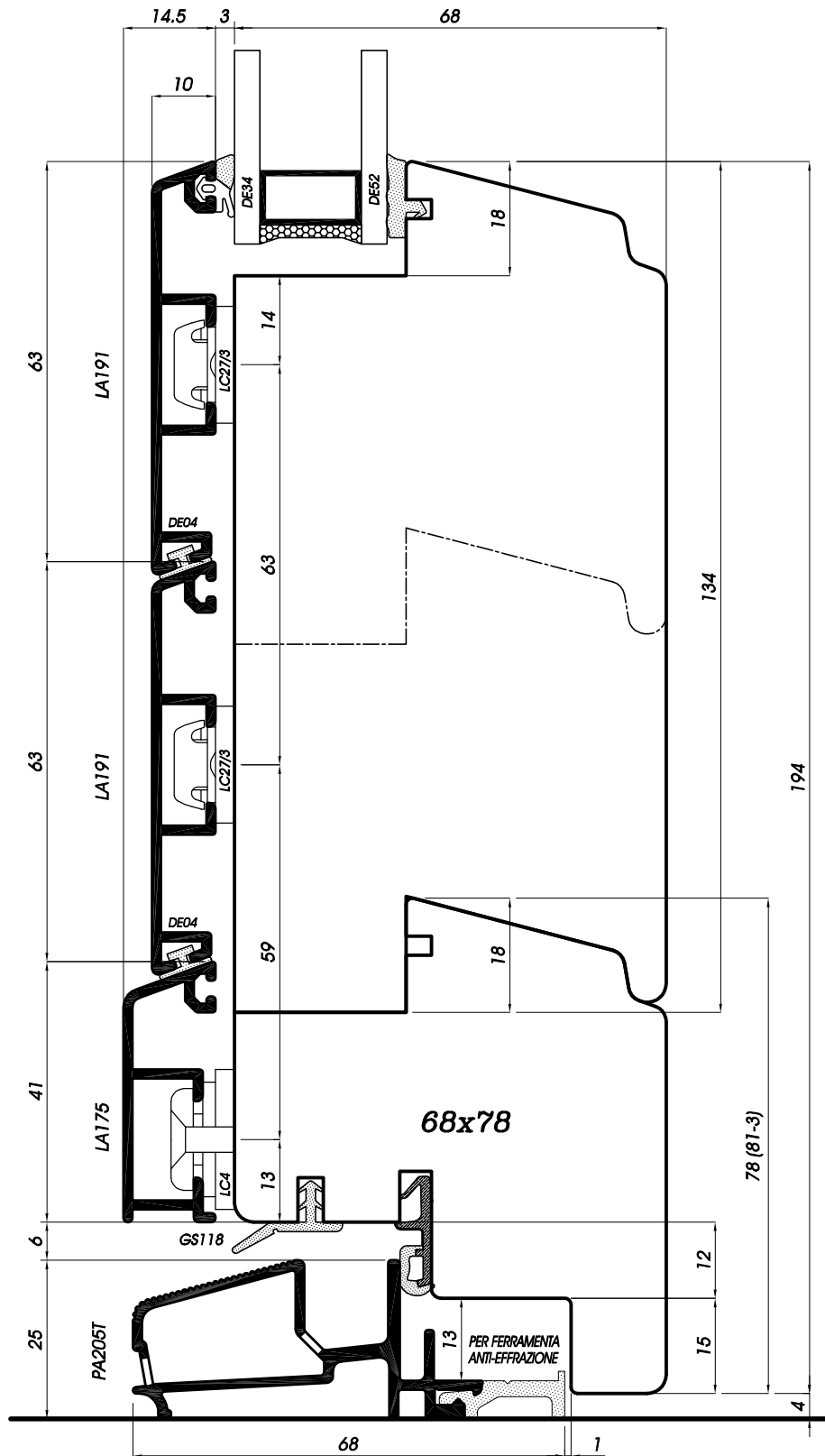
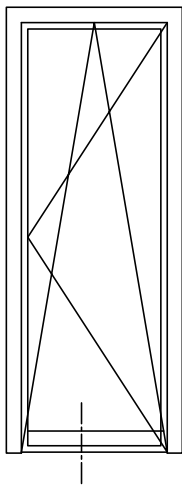

Sezione verticale traverso inferiore portafinestra con profilo PA205T  
 Vertikalschnitt Balkontür quer unten mit Profil PA205T  
 Sección vertical travesaño inferior puertaventana con perfil PA205T  
 Section verticale traverse inférieure porte-fenêtre avec profil PA205T  
 Vertical section of the window's lower ledge with profil PA205T

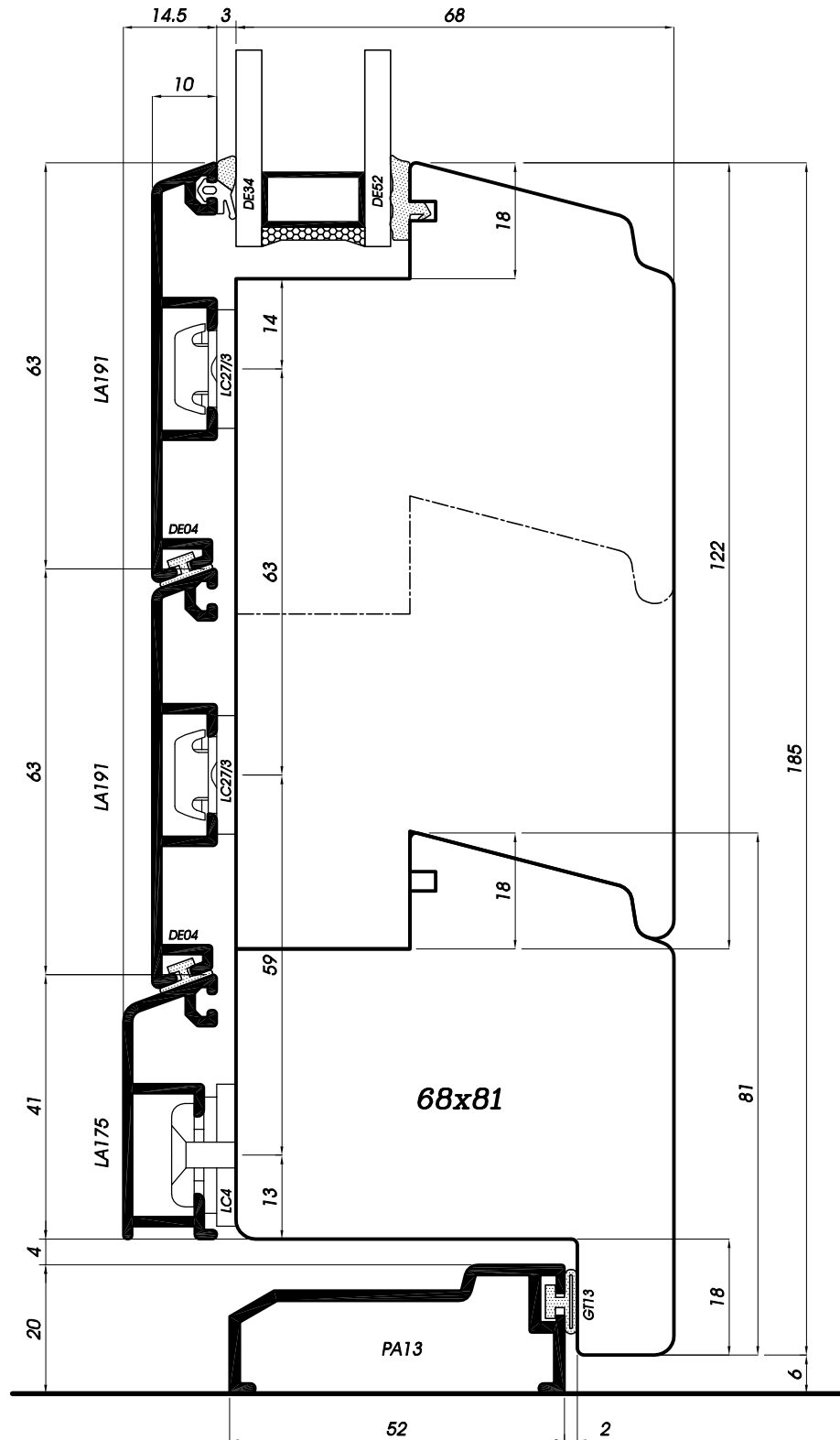
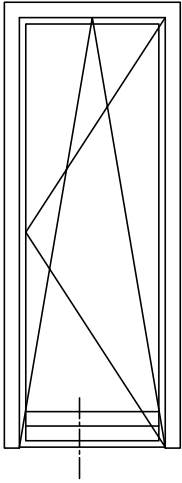

**Sezione verticale traverso inferiore portafinestra con profilo PA13**  
**Vertikalschnitt Balkontür quer unten mit Profil PA13**  
**Sección vertical travesaño inferior puertaventana con perfil PA13**  
**Section verticale traverse inférieure porte-fenêtre avec profil PA13**  
**Vertical section of the window's lower ledger with profil PA13**

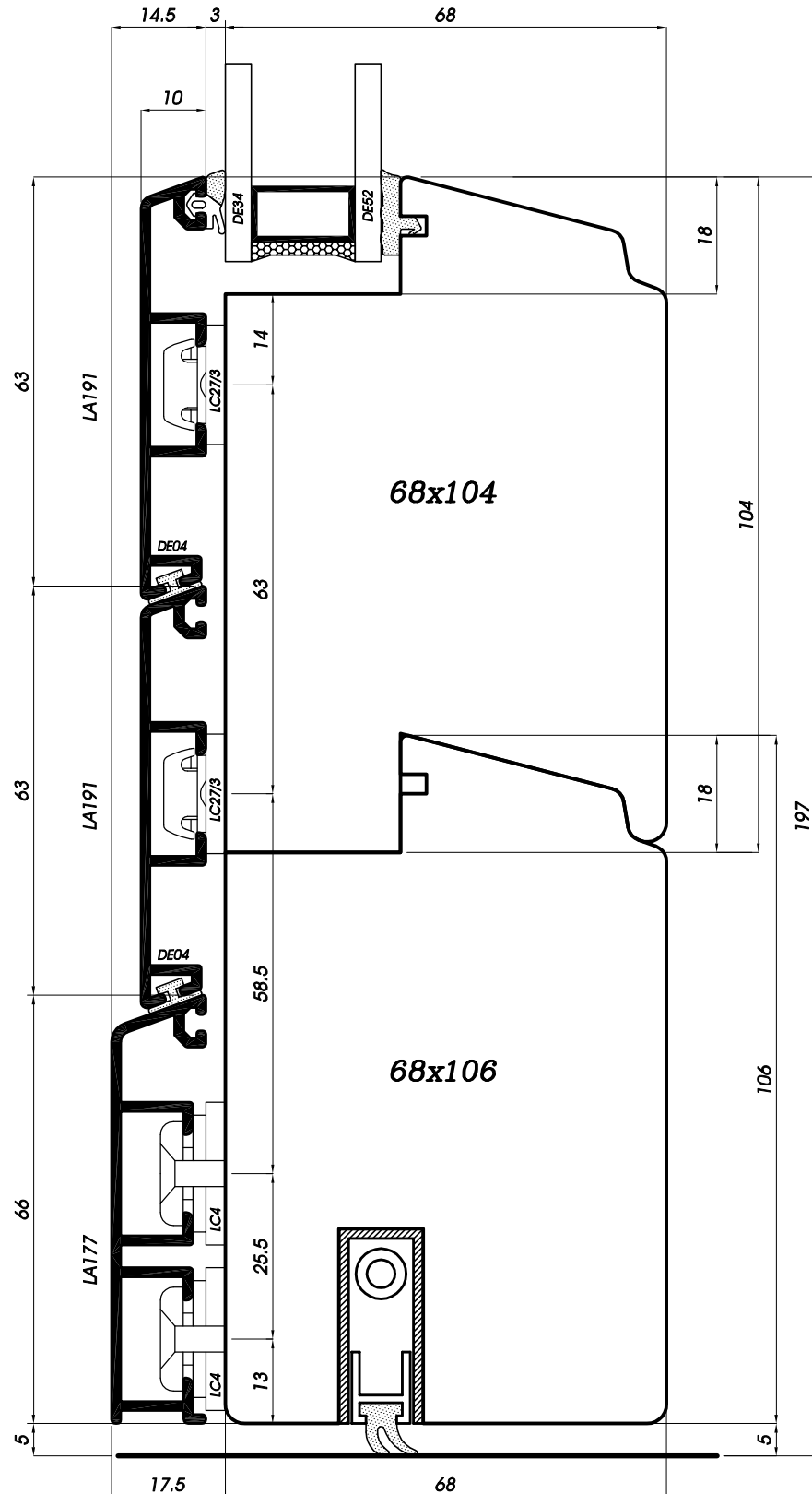
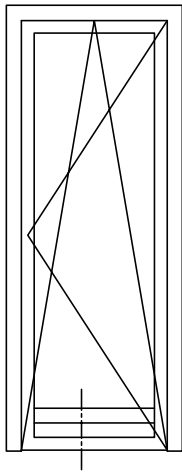

**Sezione verticale traverso inferiore portafinestra con parafreddo**  
**Vertikalschnitt Balkontür quer unten mit Kälteschutz**  
**Sección vertical travesaño inferior puertaventana con parafrío**  
**Section verticale traverse inférieure porte-fenêtre avec clonette**  
**Vertical section of the window's lower ledger with a cold-defender**

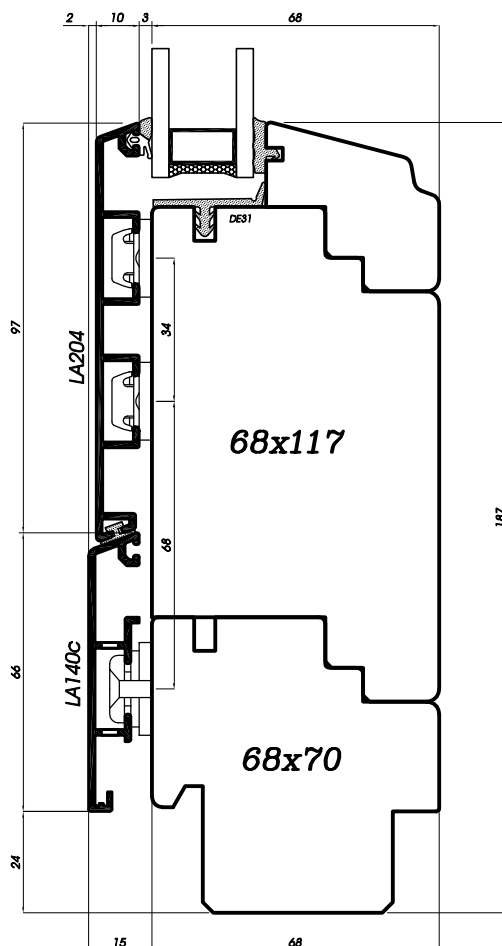
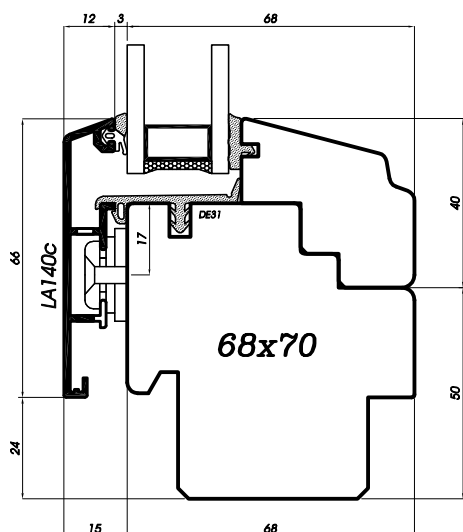
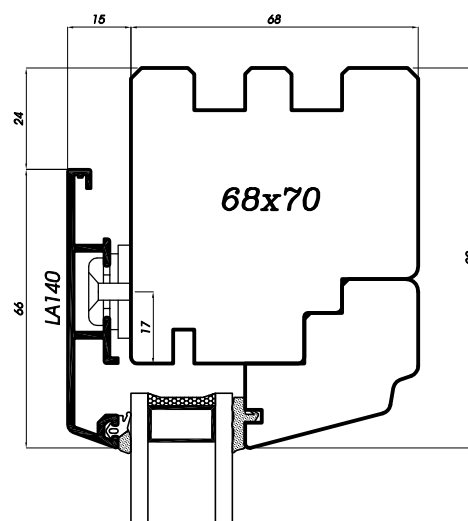
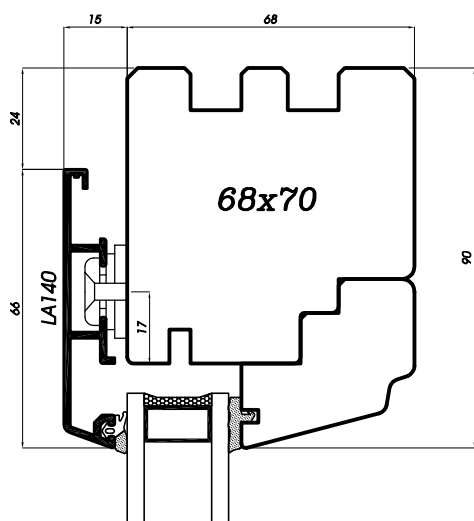

**Sezione verticale finestra e portafinestra con vetro fisso**  
**Vertikalschnitt Fenster und Balkontür mit Fixverglasung**  
**Sección vertical ventana y puertaventana con cristal fijo**  
**Coupe verticale fenêtre et porte-fenêtre avec vitre fixe**  
**Vertical section of the window's lower ledger with fixed glas**

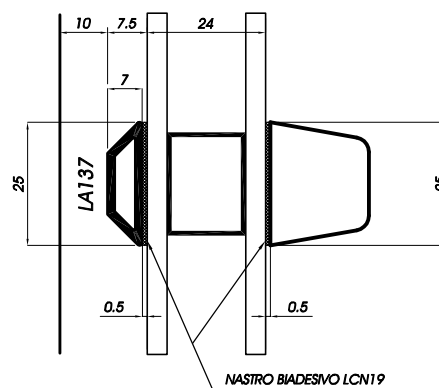
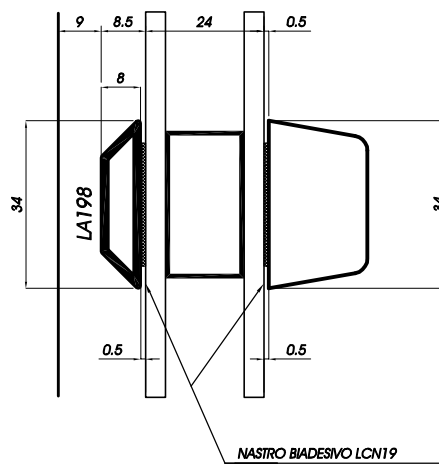
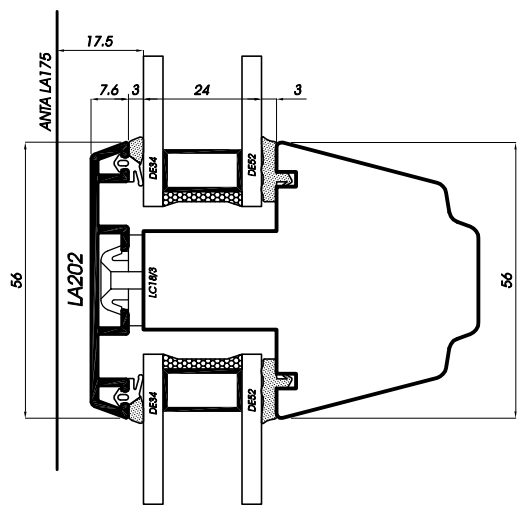
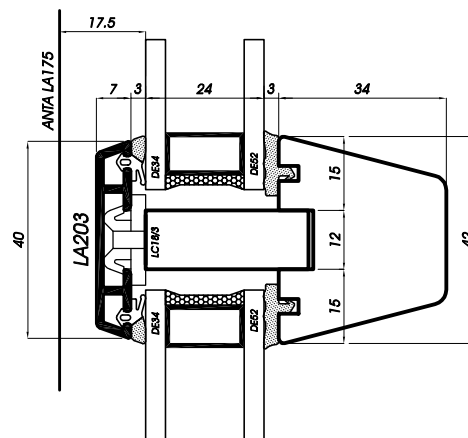
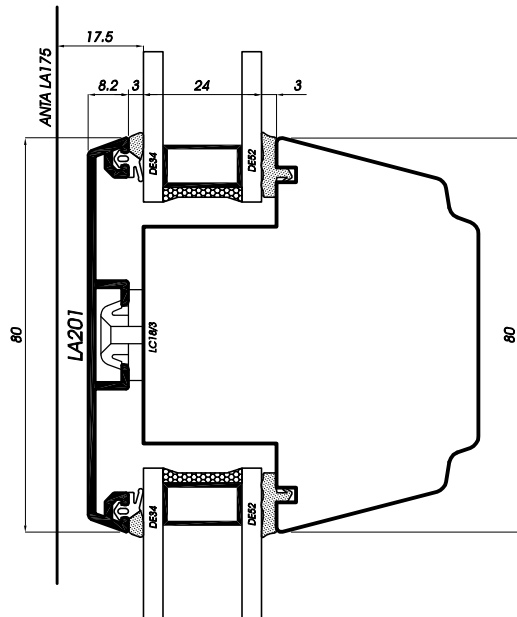

Sezione verticale traversi intermedi anta  
 Vertikalschnitt Sprossen im Flügel  
 Sección vertical travesaños intermedios de la hoja  
 Coupe verticale traverses intermédiaires vantail  
 Vertical section of the wing's middle ledgers

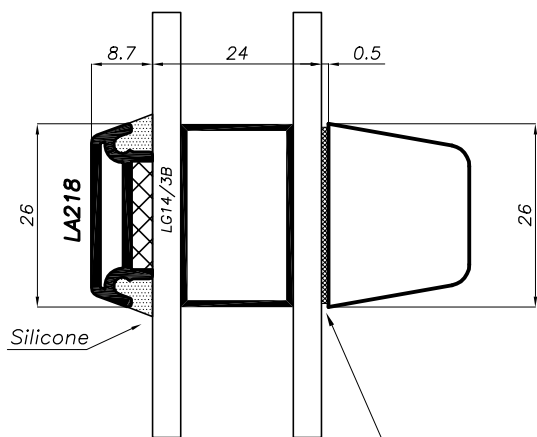
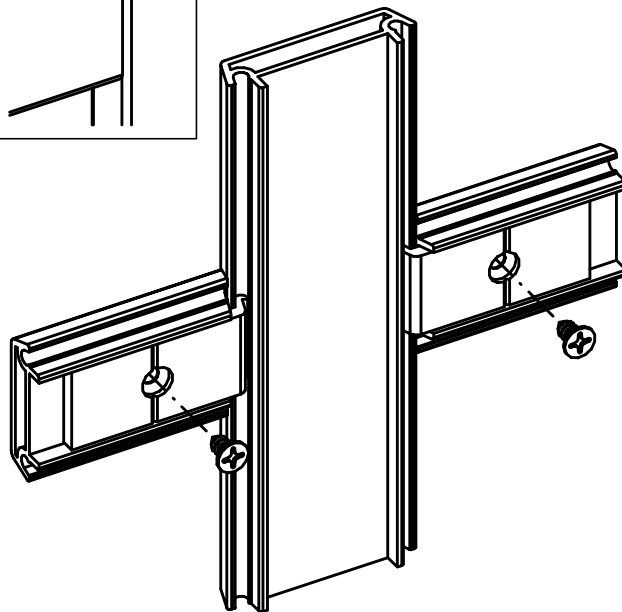
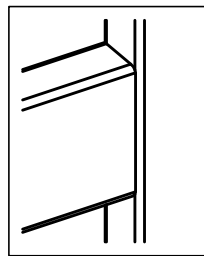
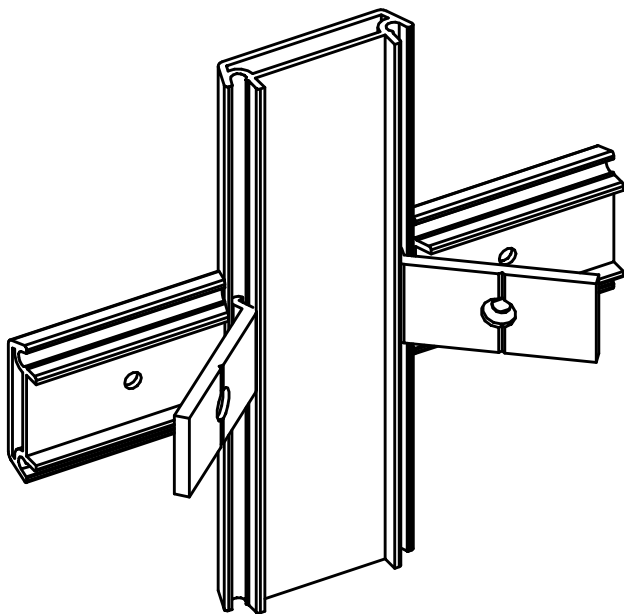

NASTRO BIADESIVO LCN19

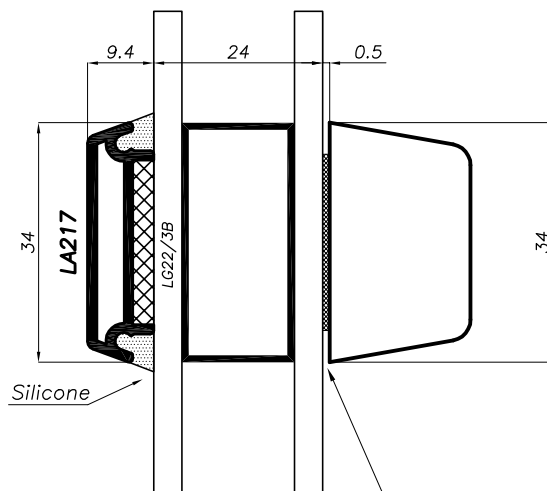

NASTRO BIADESIVO LCN19

**Assemblaggio a croce traversi anta**  
**Kreuzverbindung der Sprossen im Flügel**  
**Ensamblaje cruzado travesaños de la hoja**  
**Système d'assemblage pour croisillon**  
**Cross-Assembling of the wing's ledgers**

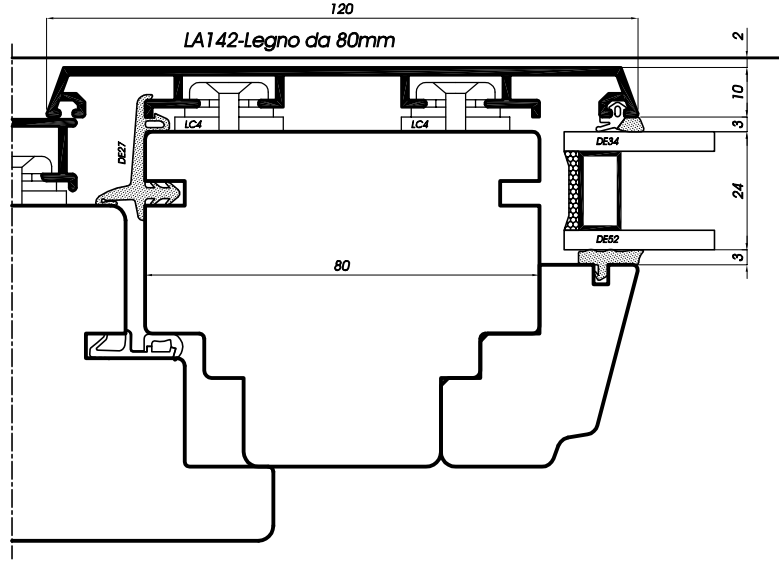
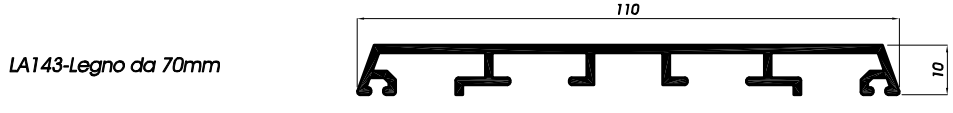
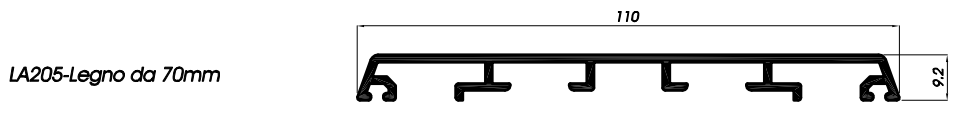
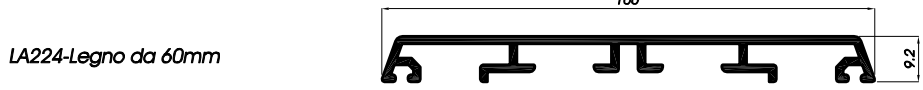
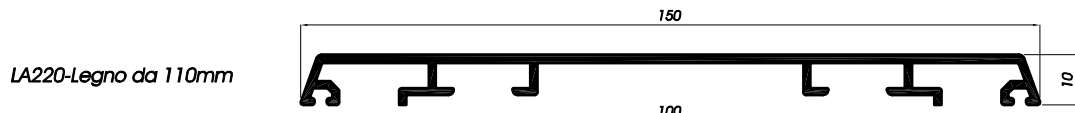
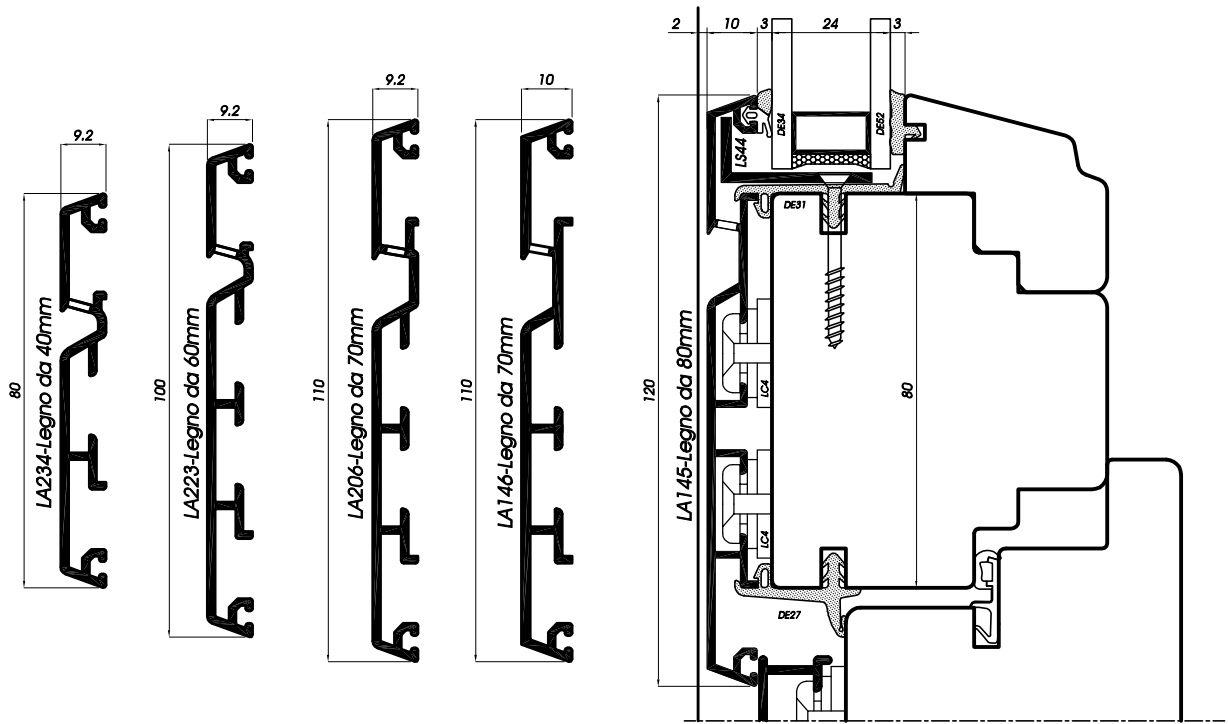

Sezione orizzontale e verticale traversi intermedi telaio  
 Horizontal- und Vertikalschnitt Rahmensprossen  
 Sección horizontal y vertical travesaños intermedios del marco  
 Coupe horizontale et verticale des traverses intermédiaires du dormant  
 Horizontal und vertical section of the frame's middle ledgers

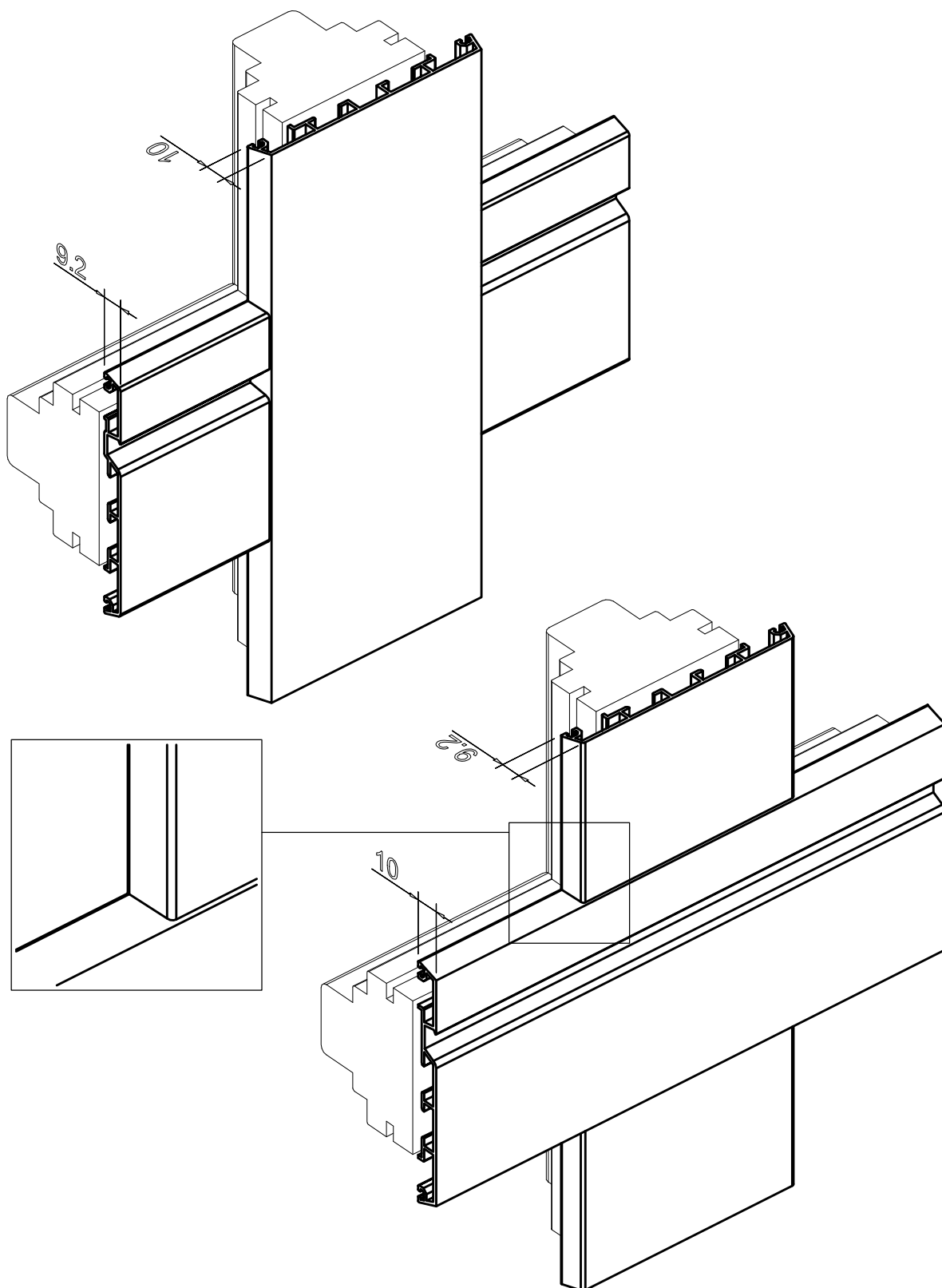

*Assemblaggio a croce traversi telaio  
Kreuzverbindung der Rahmensprossen  
Ensamblaje cruzado travesaños del marco  
Assemblage à croix des traverses du dormant  
Cross-Assembling of the frame's ledgers*



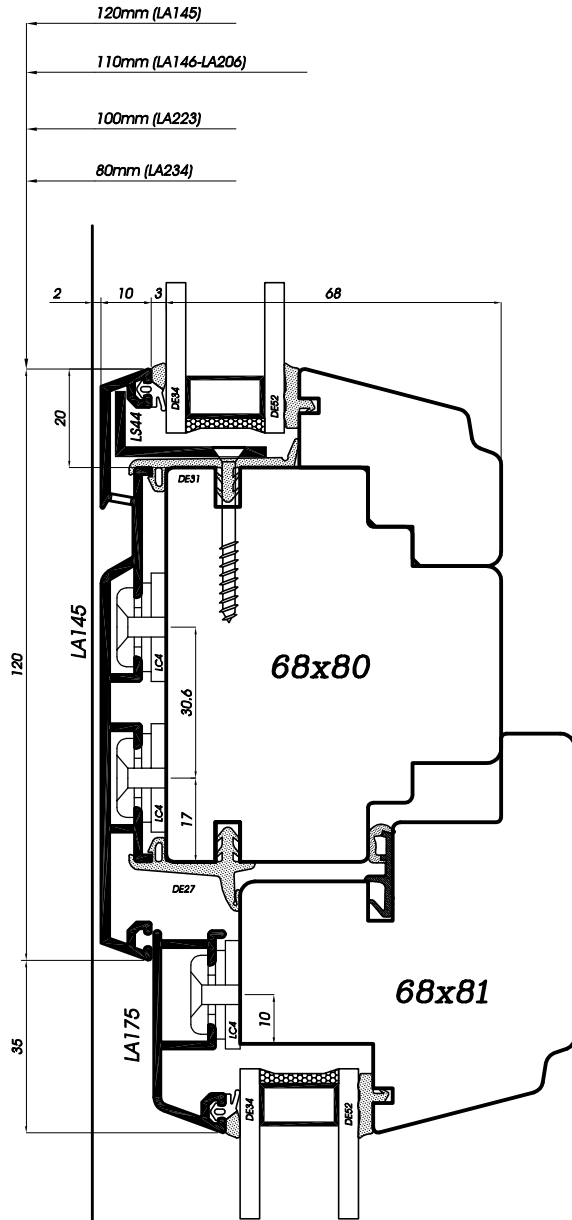
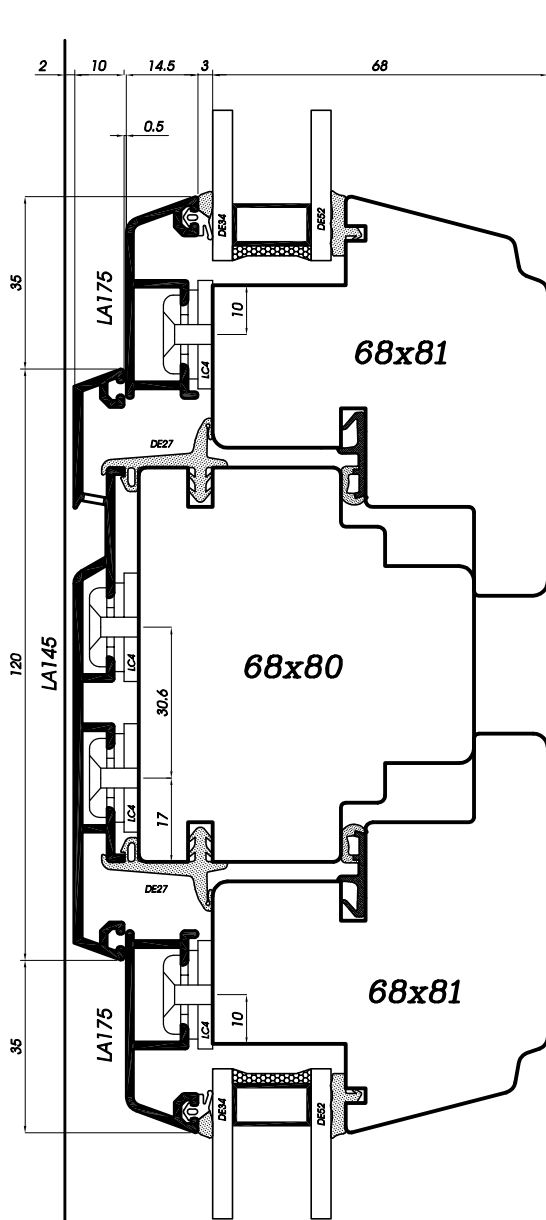
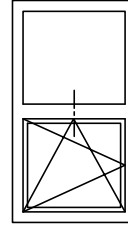
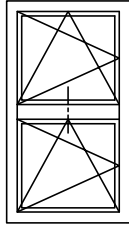

Sezione verticale traversi intermedi telaio  
 Vertikalschnitt Rahmensprossen  
 Sección vertical travesaños intermedios del marco  
 Coupe verticale des traverses intermédiaires du dormant  
 Vertical section of the frame's middle ledgers

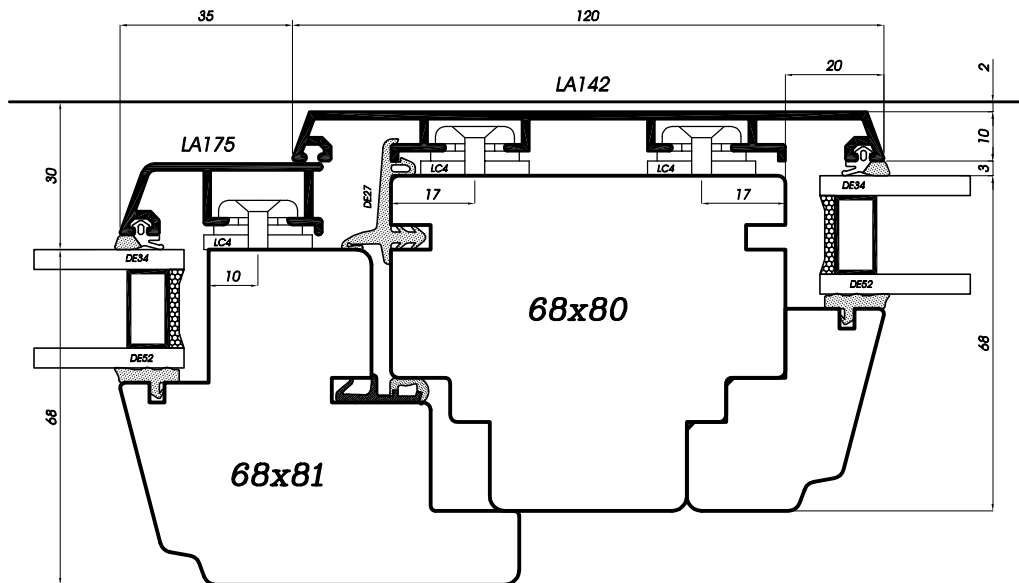
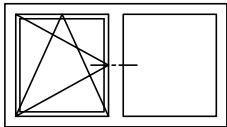
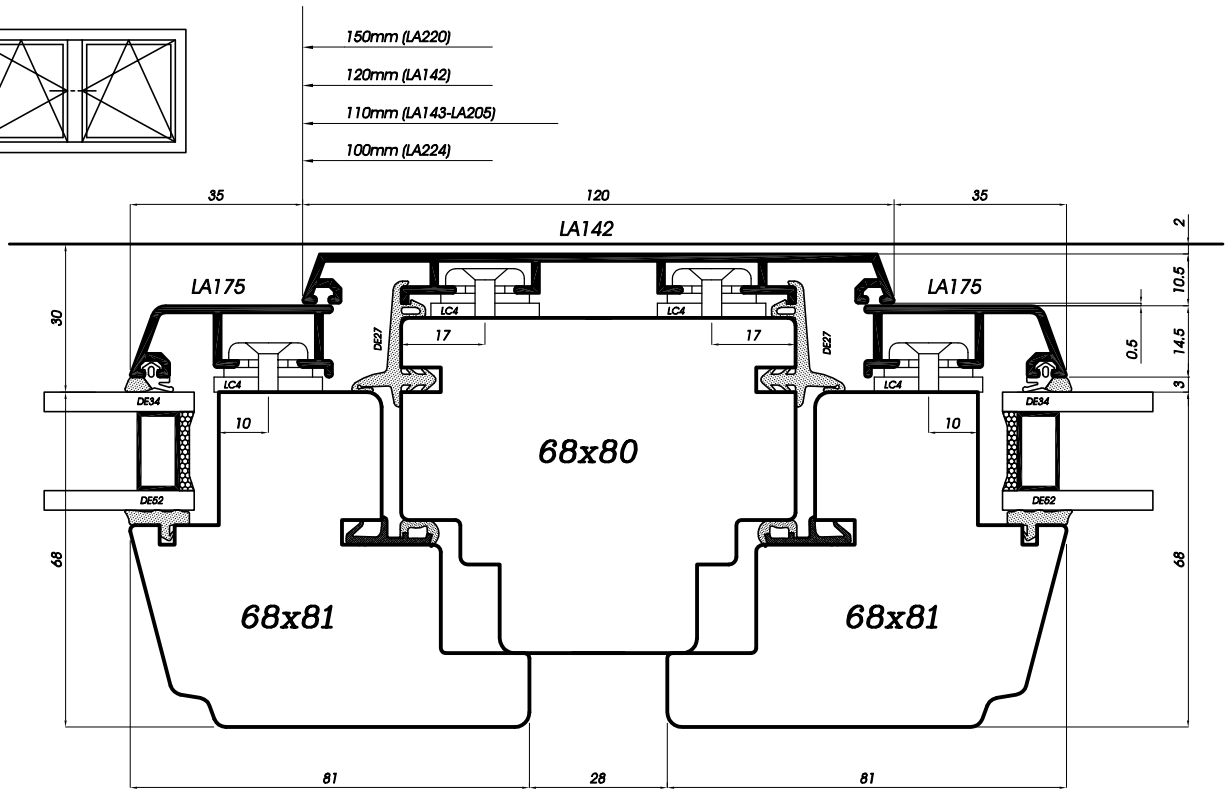
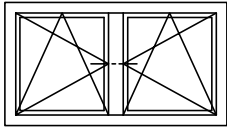

**Sezione orizzontale montanti intermedi telaio**  
**Horizontalschnitt Setzholz Rahmen**  
**Sección horizontal montantes intermedios del marco**  
**Coupe horizontale montants intermédiaires dormant**  
**Horizontal section of the frame's middle jambs**

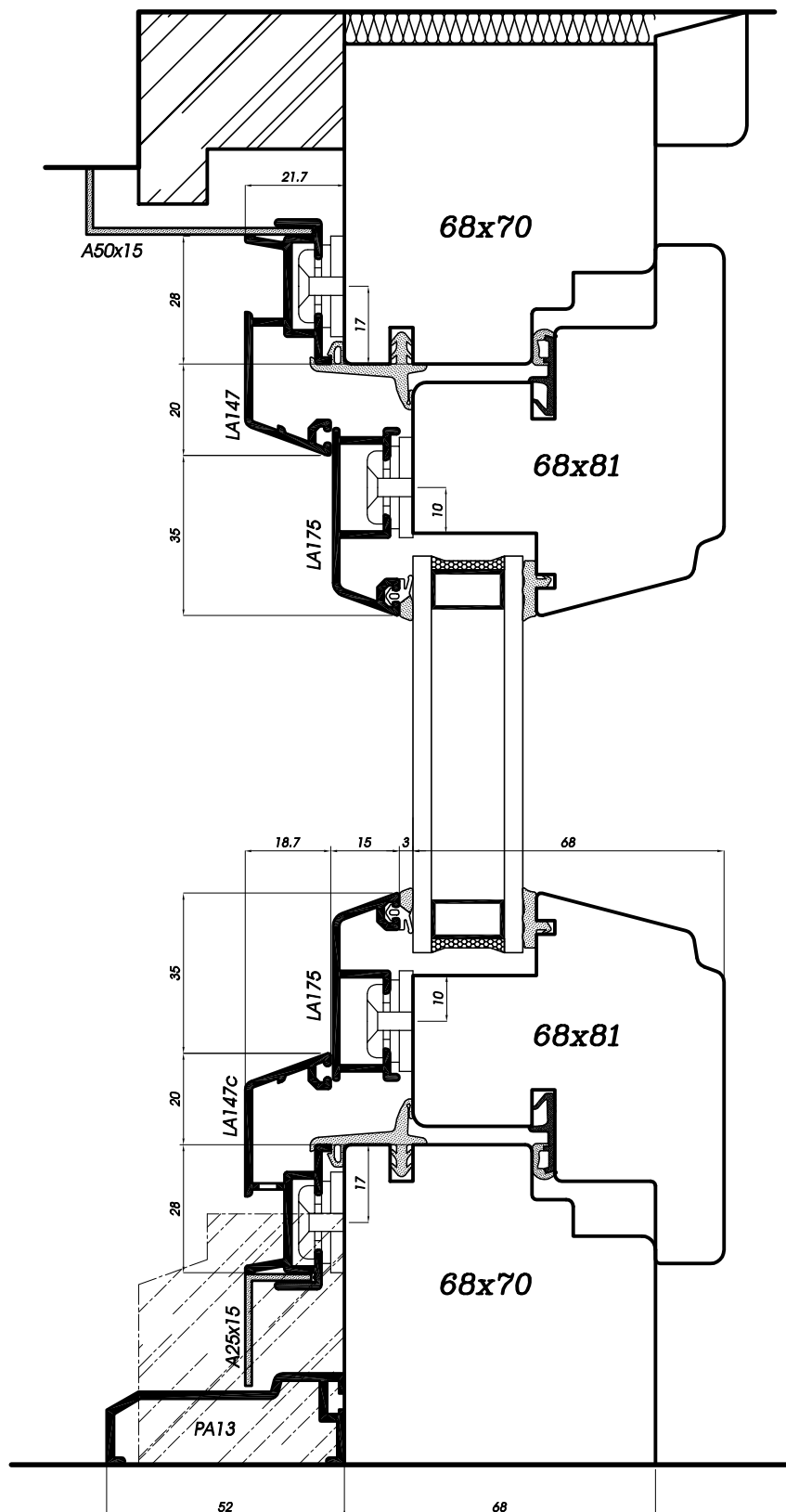
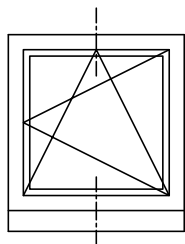

**Sezione verticale con profilo LA147c+PA13 per la ristrutturazione**  
**Vertikalschnitt mit Profil LA147c+PA13 für Sanierung**  
**Sección vertical con perfil LA147c+PA13 para la rehabilitación**  
**Coupe verticale avec profil LA147c+PA13 pour la rénovation**  
**Vertical section with profile LA 147C+Pa13 for the redevelopment**

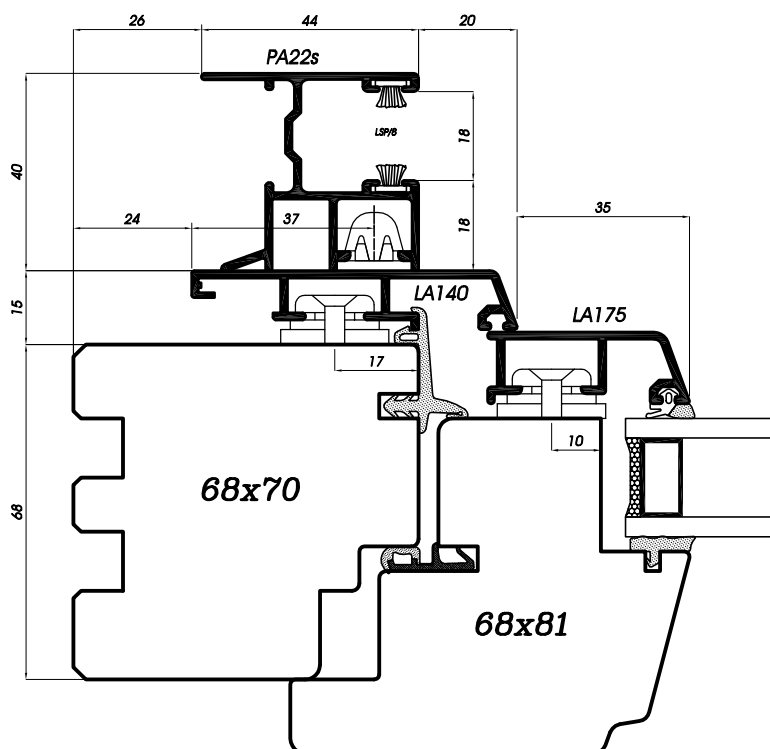
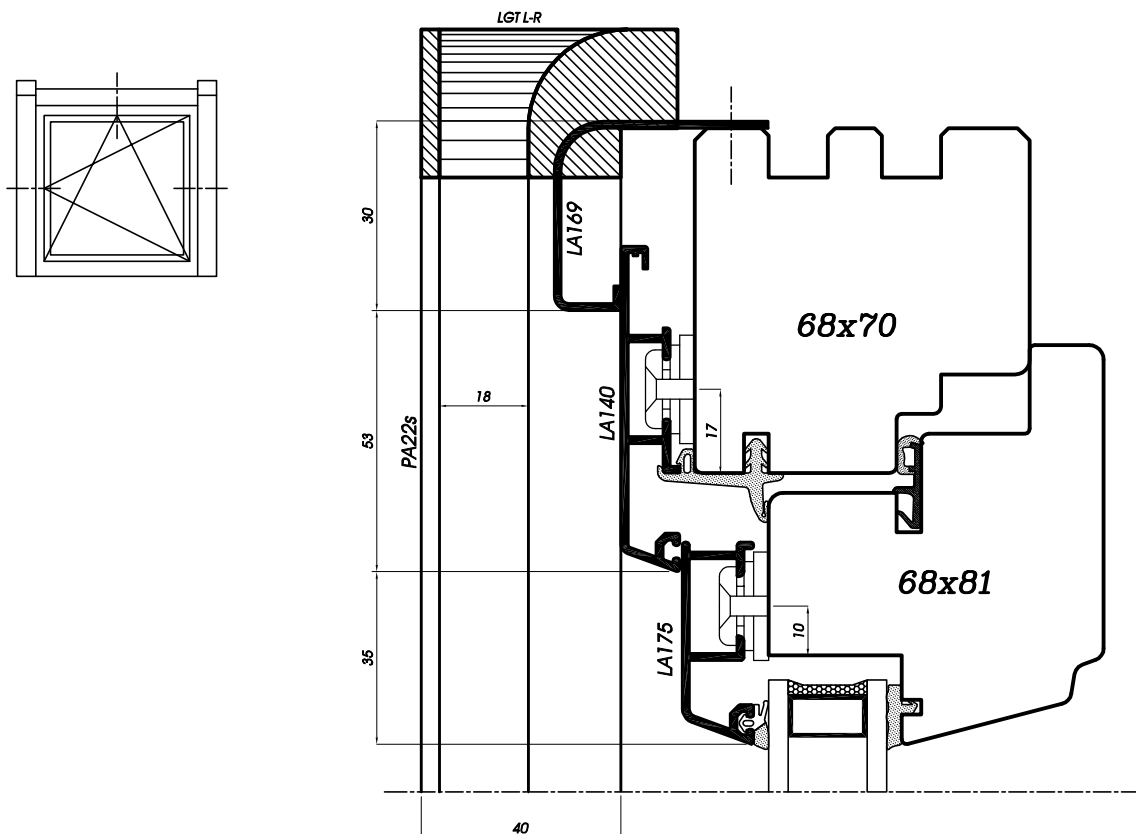

**Sezione verticale e orizzontale con guida avvolgibile PA22s**  
**Vertikal- und Horizontalschnitt mit Rolladenführung PA22s**  
**Sección vertical y horizontal con guía de persiana PA22s**  
**Coupe verticale et horizontale avec coulisses volet roulant PA22s**  
**Vertical and horizontal section with a winding up guide PA22S**

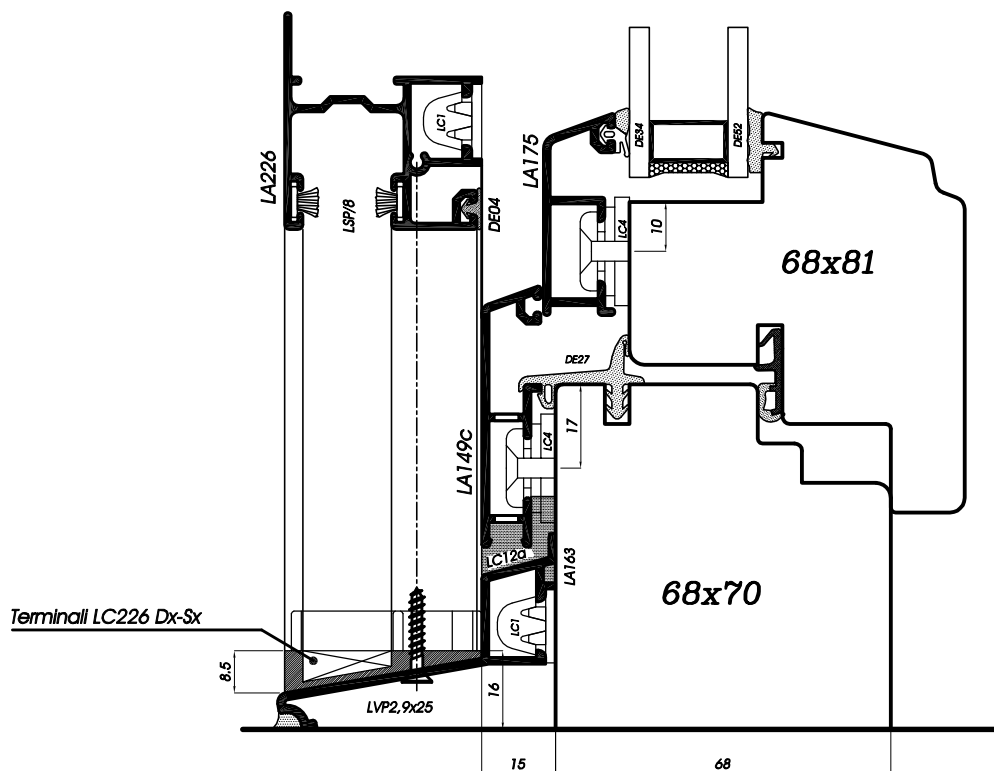
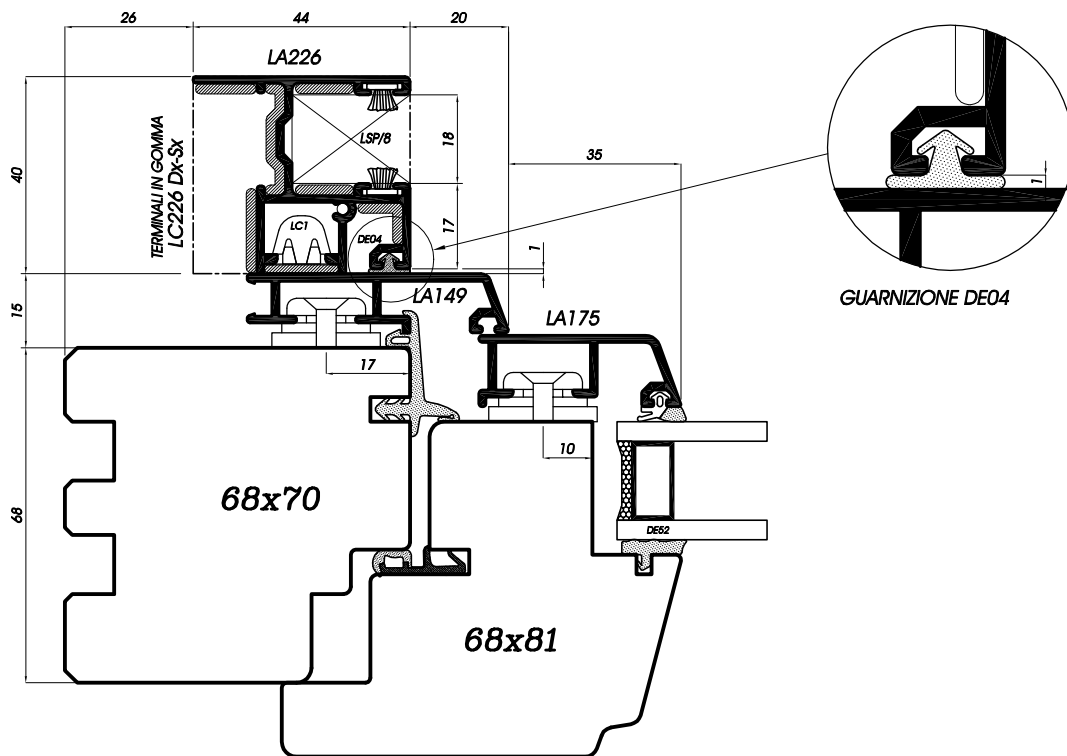

Sezione verticale e orizzontale con guida avvolgibile LA226  
 Vertikal- und Horizontalschnitt mit Rolladenführung LA226  
 Sección vertical y horizontal con guía de persiana LA226  
 Coupe verticale et horizontale avec coulisses volet roulant LA226  
 Vertical and horizontal section with a winding up guide LA226

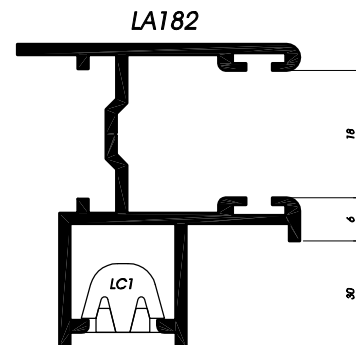
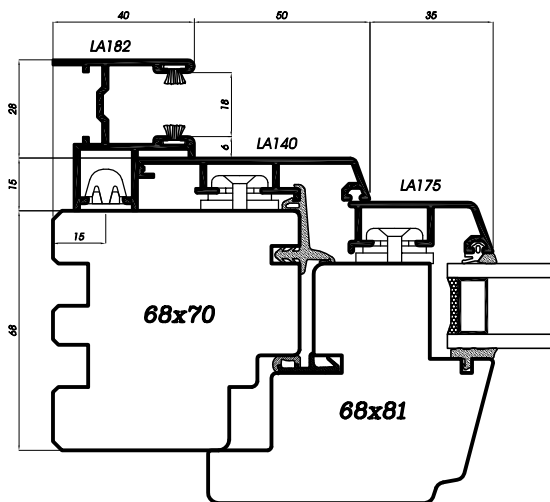
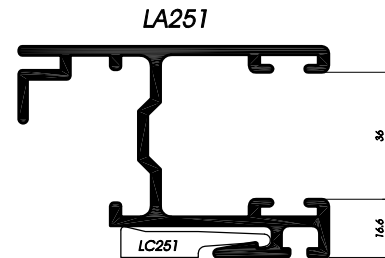
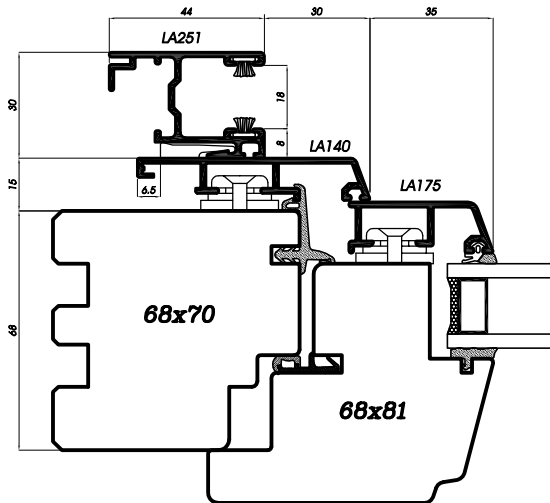
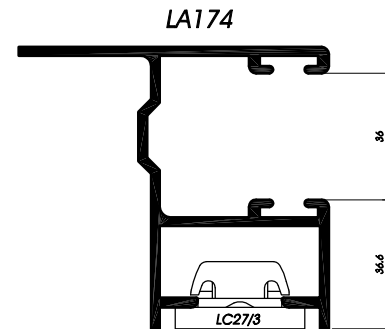
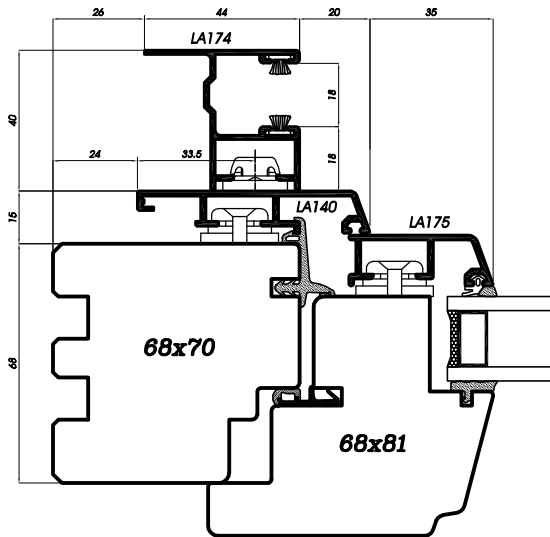

Sezione orizzontale con guide avvolgibili LA174-LA251-LA182  
 Vertikal- und Horizontalschnitt mit Rolladenführung LA174-LA251-LA182  
 Sección horizontal con guías de persiana LA174-LA251-LA182  
 Coupe horizontale avec coulisses volet roulant LA174-LA251-LA182  
 Horizontal section with a winding up guides LA174-LA251-La182

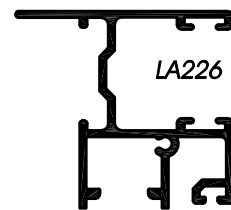
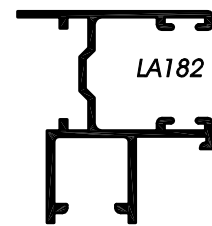
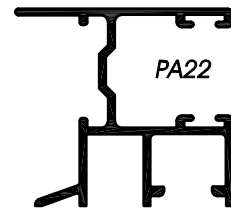
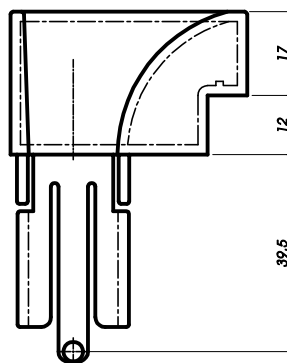
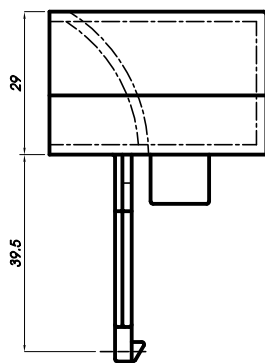
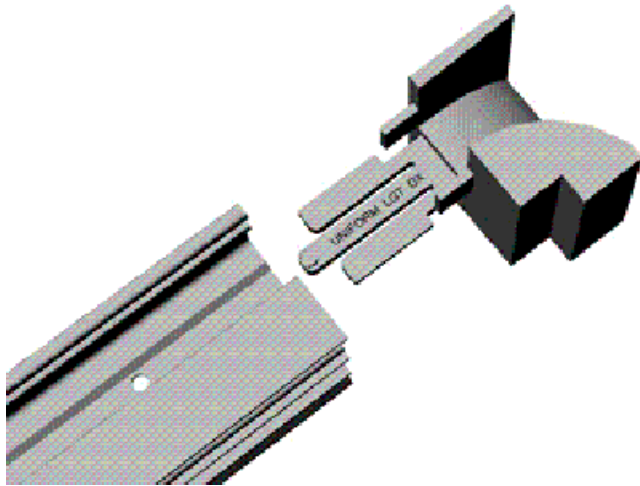

*Eseguire foro  $\varnothing 4\text{mm}$  a 39,5mm con dima LD25*

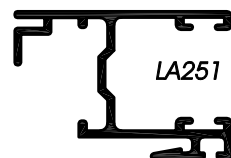
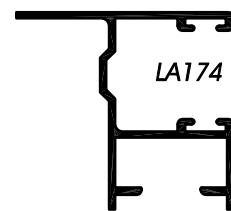
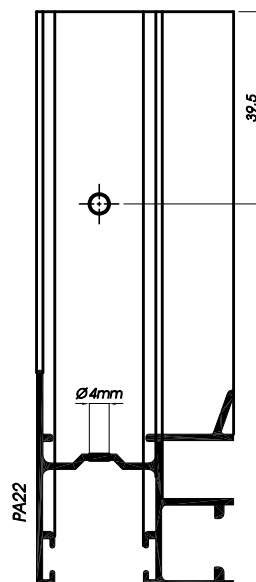
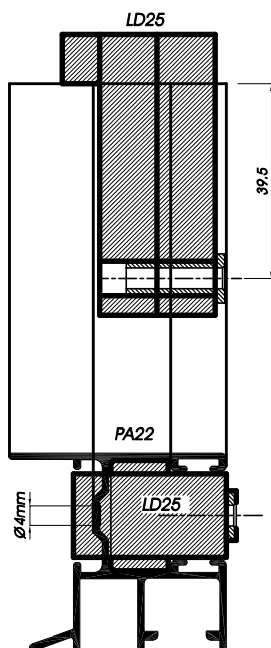

*Nuovo terminale LGT e modalità di impiego della nuova dima LD25  
 Neue Endstücke LGT und Anwendung der neuen Lehre LD25  
 Nuevo terminal LGT y modo de empleo de la nueva plantilla LD25  
 Nouvel embout LGT et exemple d'utilisation du gabarit LD25  
 New terminal LGT and using modality for the new template LD25*

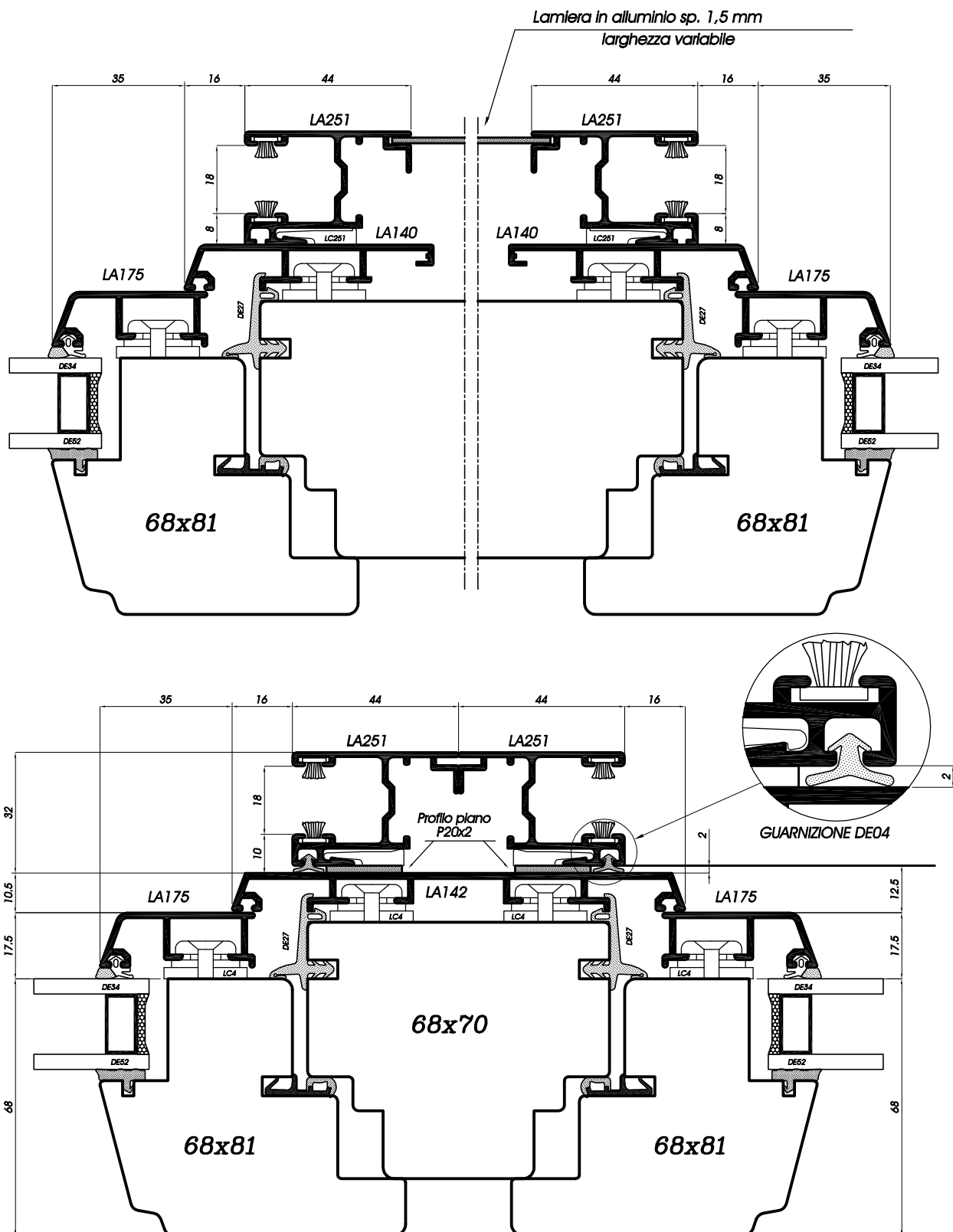

**Sezione orizzontale finestre accoppiate con LA251**  
**Horizontalschnitt gekoppelte Fenster mit LA251**  
**Sección horizontal de ventanas acopladas**  
**Coupe horizontale accouplement de dormants avec LA251**  
**Horizontal section of the connected windows with LA 251**



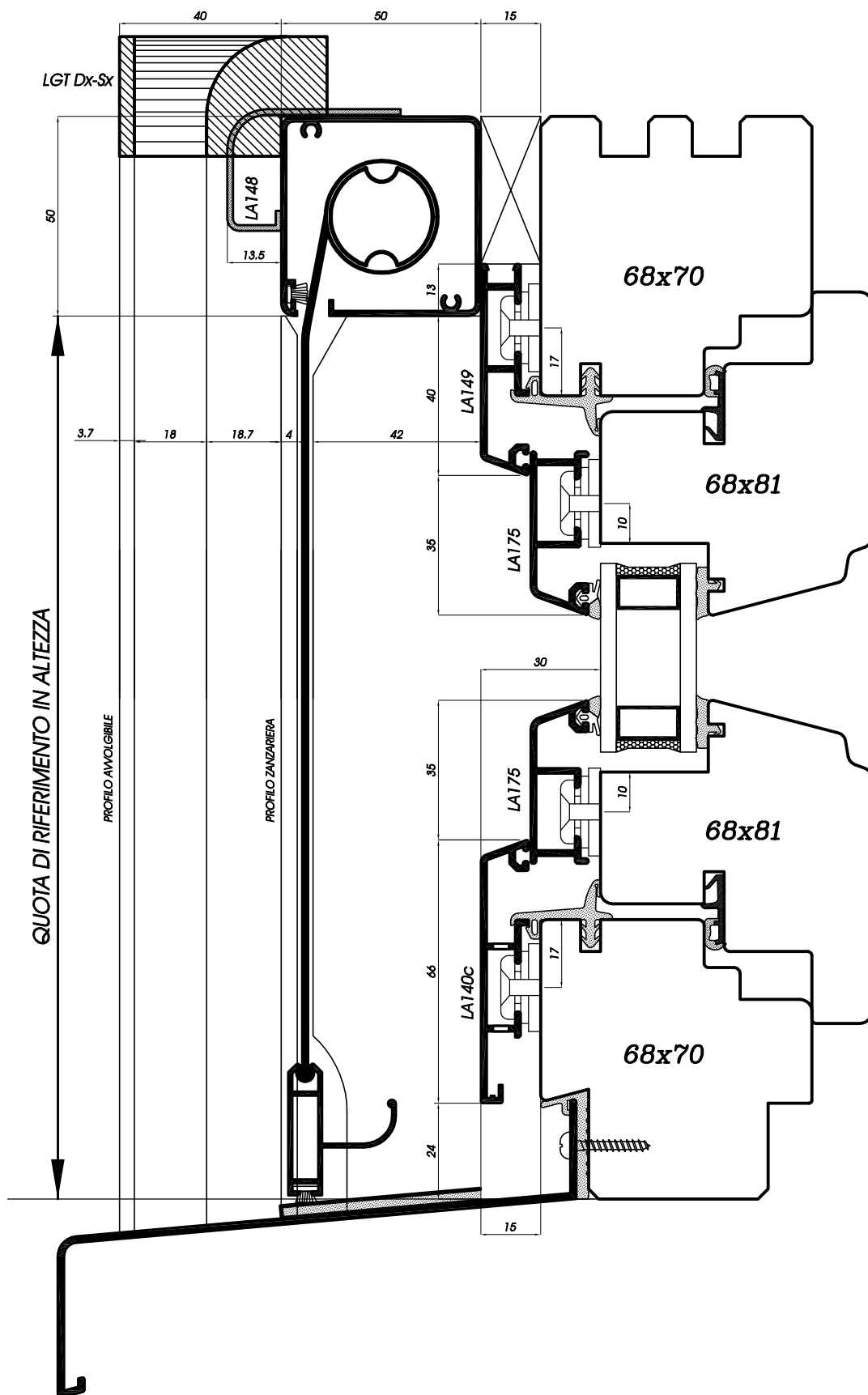

Sezione verticale con zanzariera e guida avvolgibile  
 Vertikalschnitt mit Fliegengitter und Rolladenführung  
 Sección vertical ventana con mosquitera y guía de persiana  
 Coupe verticale avec moustiquaire et coulisses volet roulant  
 Vertical section with mosquito-net and turning guide

**ZANZARIERE - DIMENSIONI MASSIME REALIZZABILI**

- L 2000 x H 1600 - Finestra Verticale
- L 1600 x H 2400 - Portafinestra Verticale
- L 1500 x H 2500 - Scorrimento orizzontale 1 anta
- L 2800 x H 2500 - Scorrimento orizzontale 2 ante

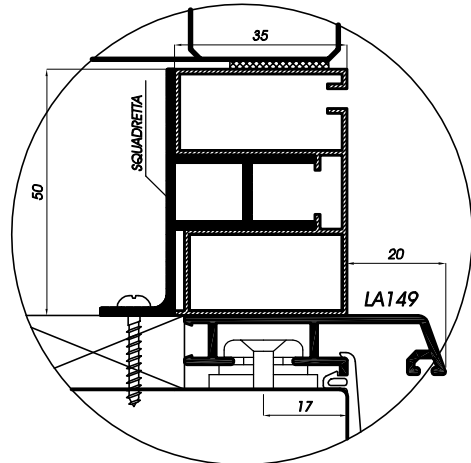

*Variante senza guida avvolgibile*

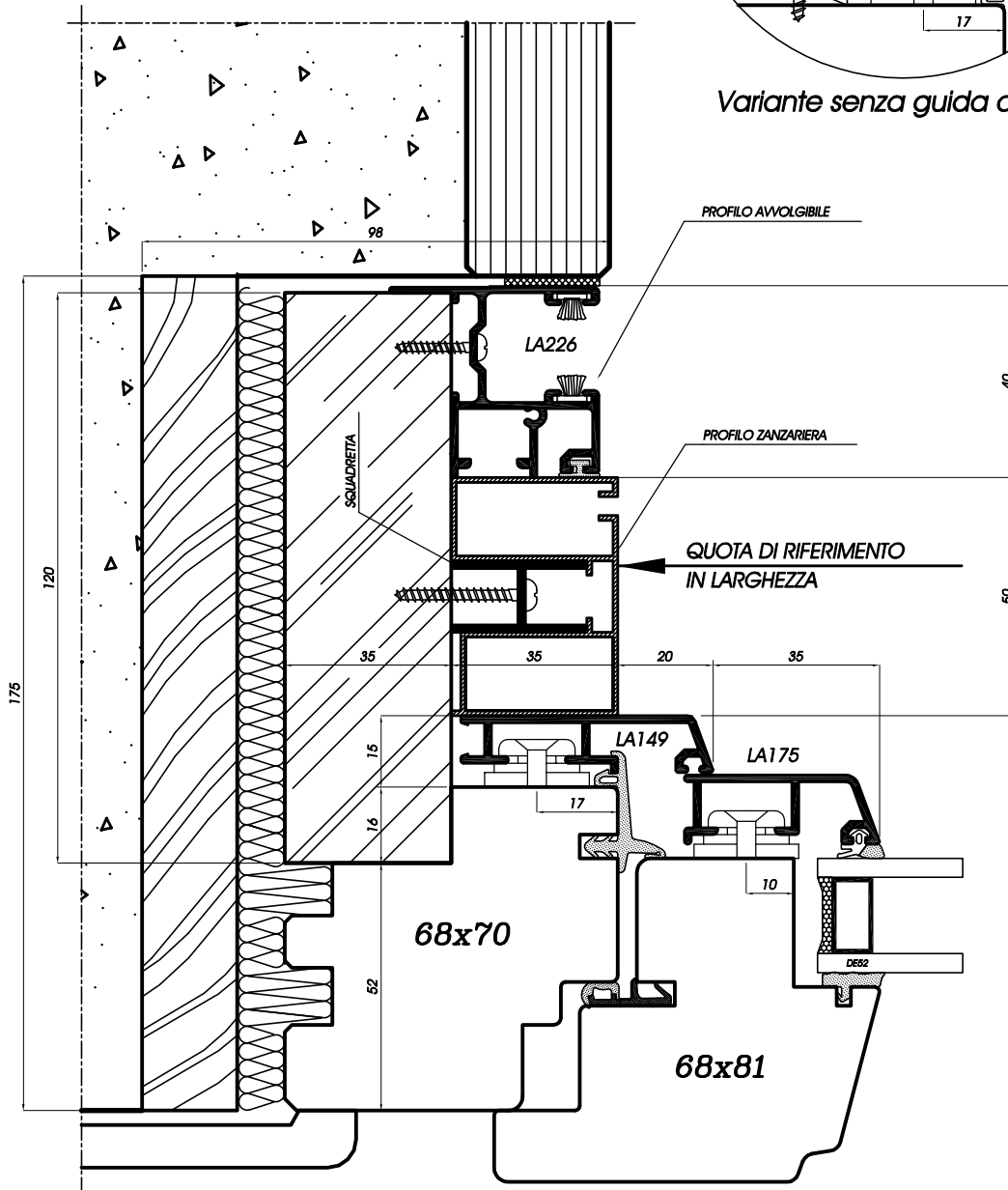

**Sezione orizzontale con zanzariera e guida avvolgibile**  
**Horizontalschnitt mit Fliegengitter und Rolladenführung**  
**Sección horizontal ventana con mosquitera y guía de persiana**  
**Coupe horizontale avec moustiquaire et coulisses volet roulant**  
**Horizontal section with mosquito-net and turning guide**

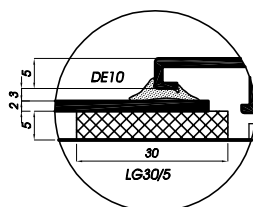
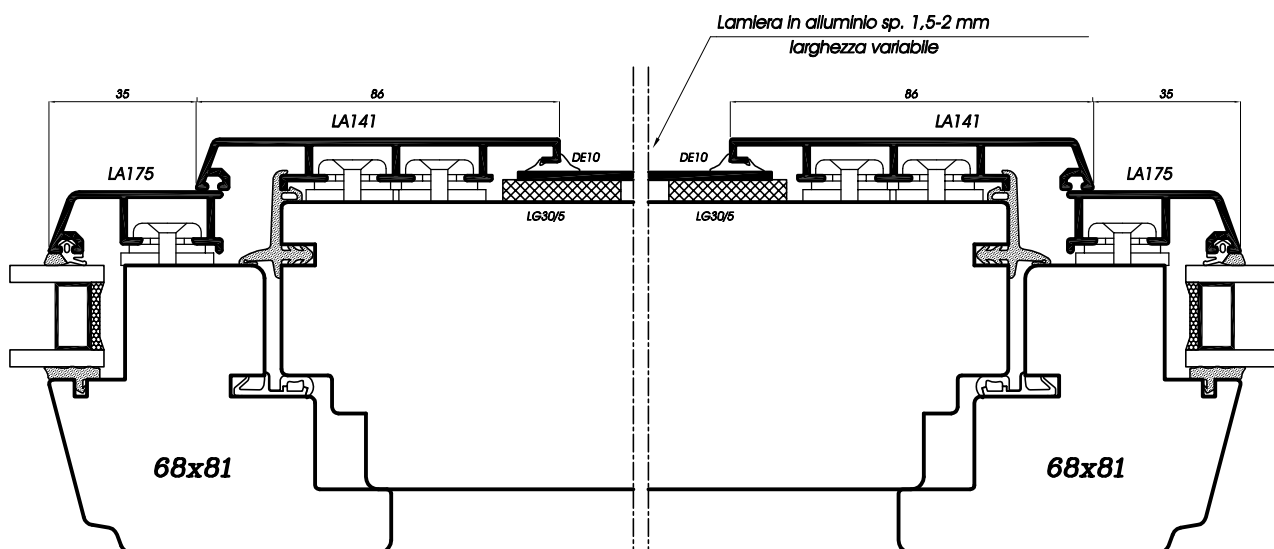

GUARNIZIONE DE10

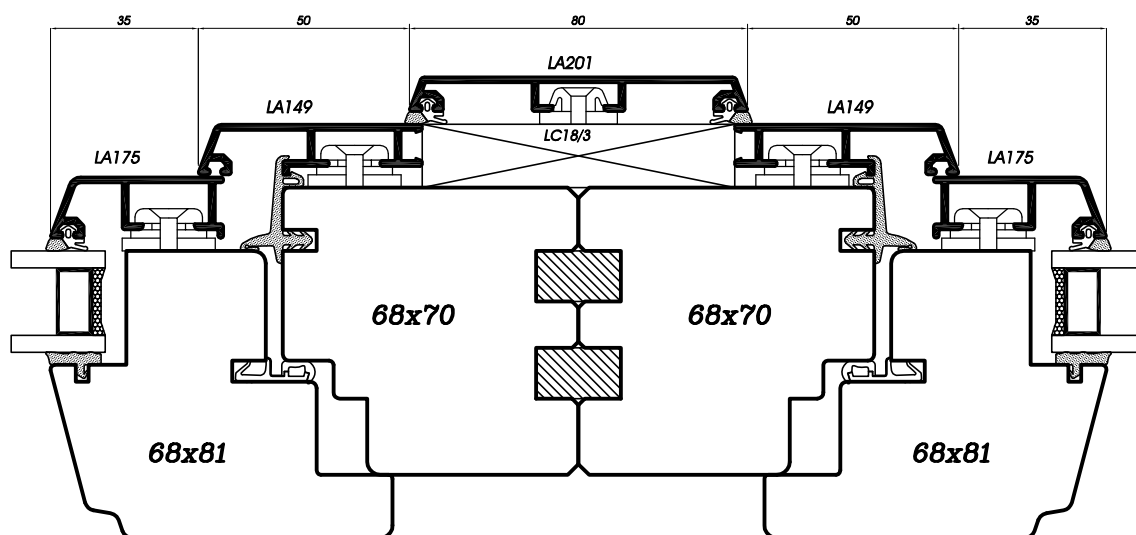

Sezione orizzontale finestre accoppiate  
 Horizontalschnitt gekoppelte Fenster  
 Sección horizontal de ventanas acopladas  
 Coupe horizontale accouplement de dormants  
 Horizontal section of the connected windows

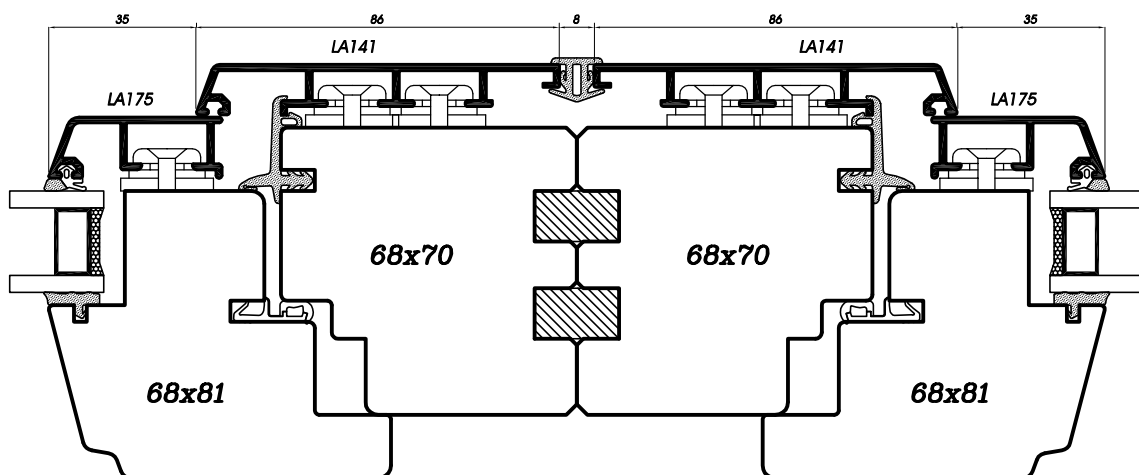
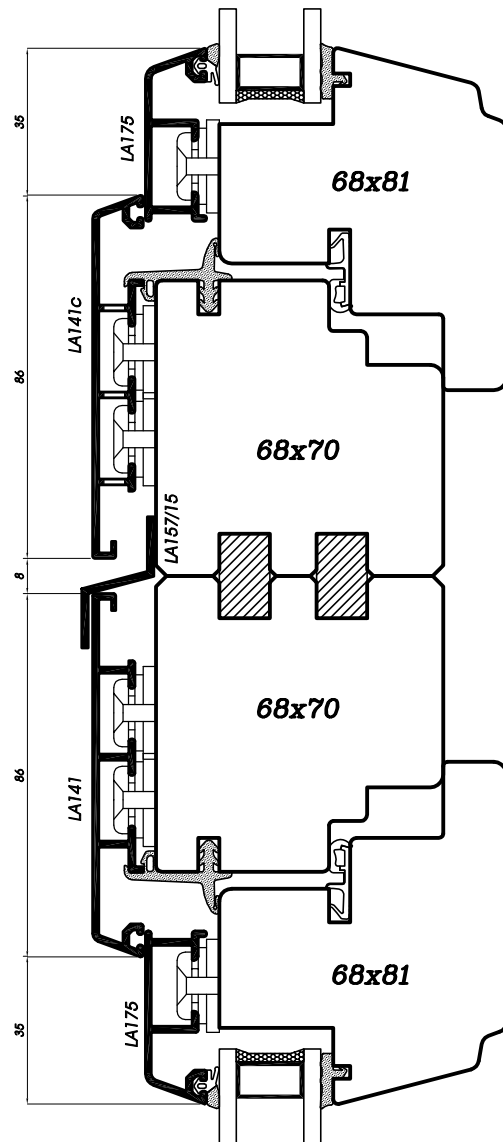
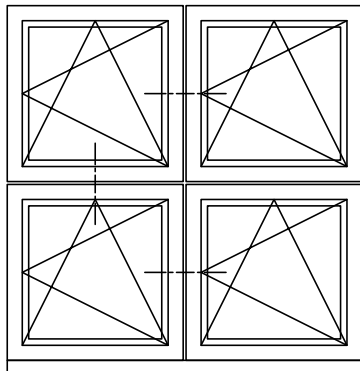

Sezione orizzontale e verticale finestre accoppiate con telaio larghezza 70 mm.  
 Horizontal- und Vertikalschnitt gekoppelte Fenster mit Rahmenbreite 70mm  
 Sección horizontal y vertical de ventanas acopladas con anchura del marco de madera de 70 mm  
 Coupe horizontale et verticale fenêtrés accouplement de dormants largeur 70 mm  
 Horizontal and Vertical section of the connected windows with a frame's breadth of 70mm

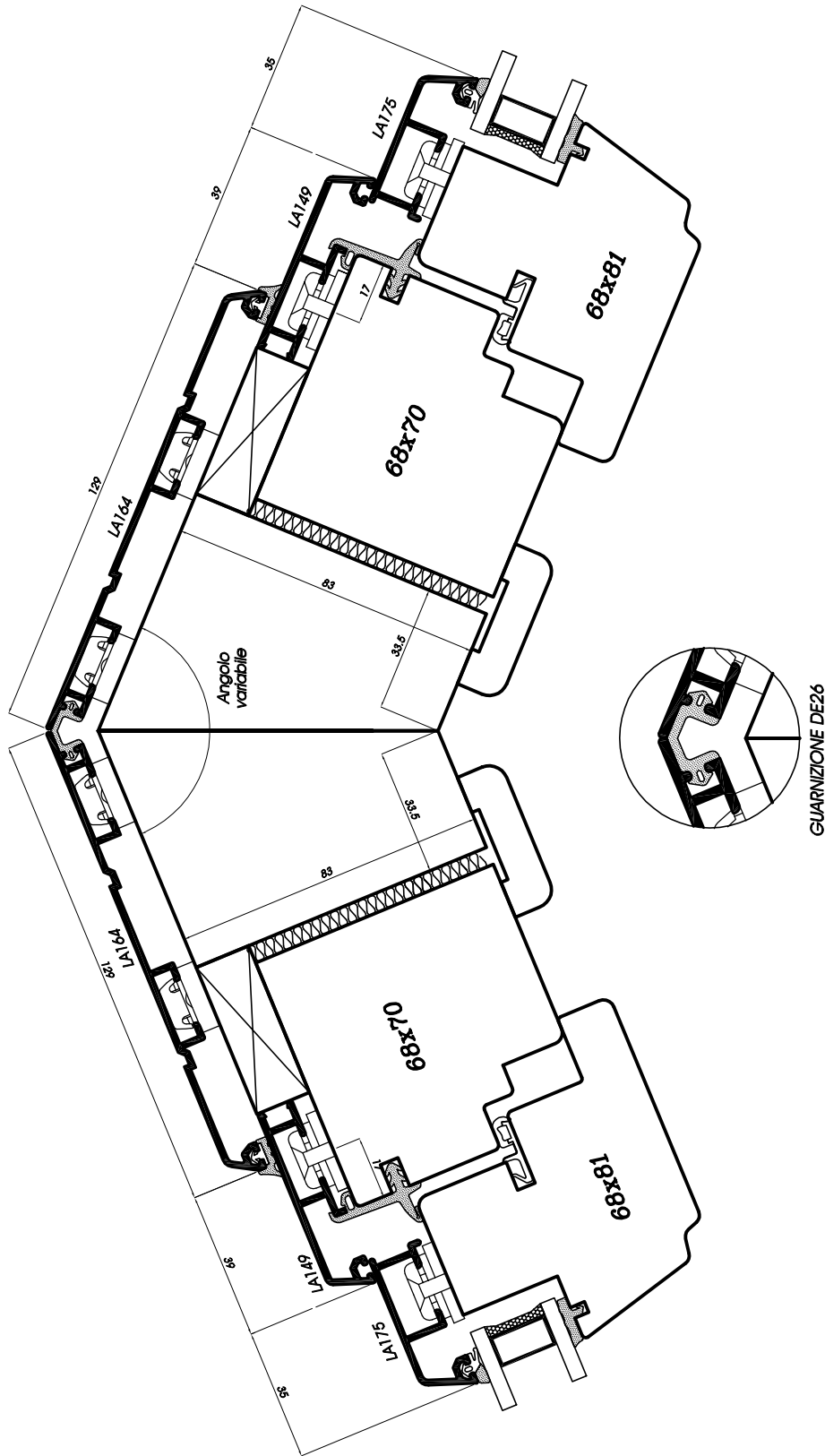

**Sezione orizzontale finestre accoppiate con inclinazione variabile**  
**Horizontalschnitt gekoppelte Fenster mit regulierbarer Neigung**  
**Sección horizontal de ventanas acopladas de inclinación variable**  
**Coupe horizontale accouplement de dormants à angle variable**  
**Horizontal section of the connected windows with a variable angle**

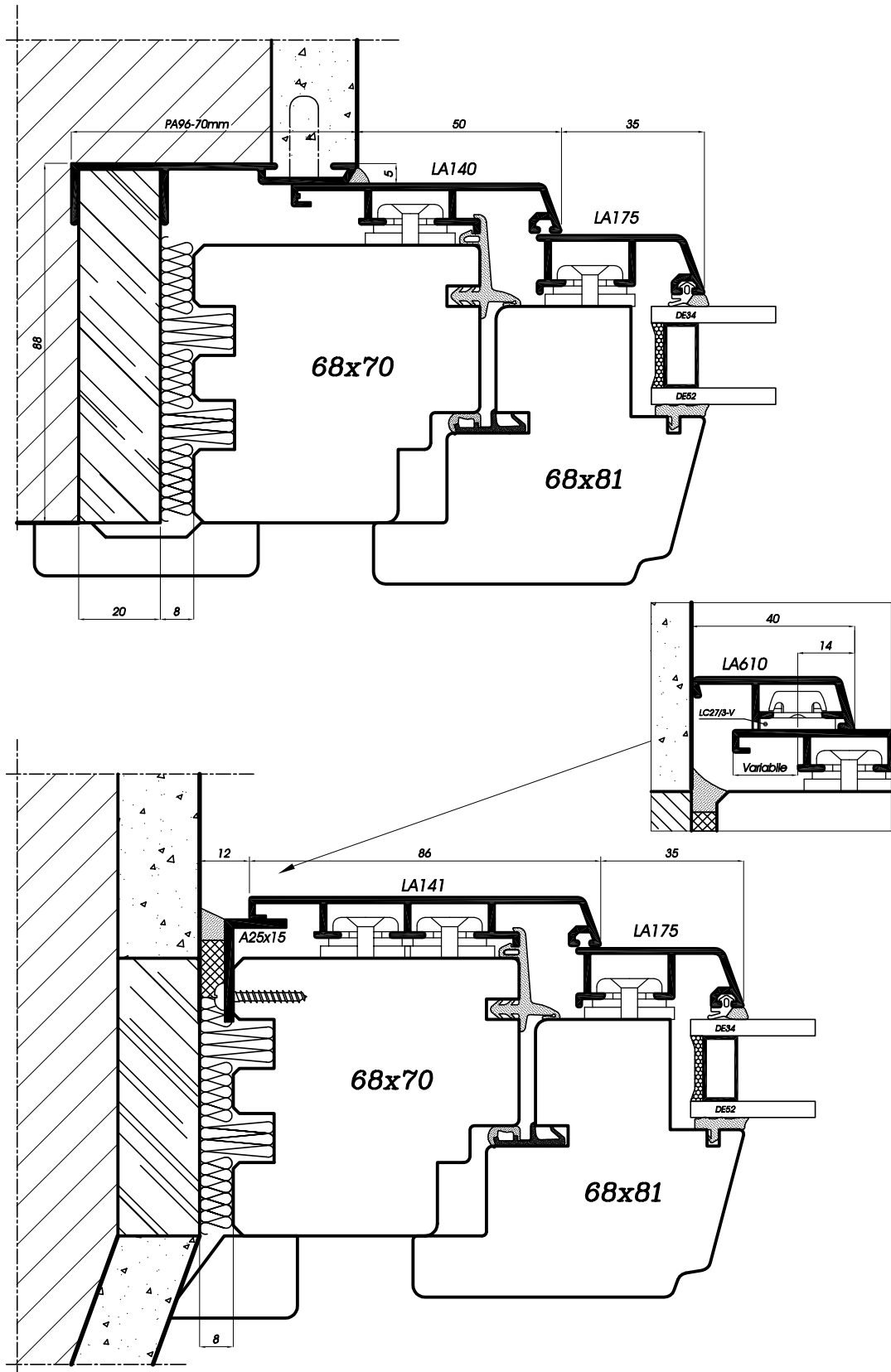

**Sistemi di posa**  
**Montagesysteme**  
**Sistemas de colocación**  
**Systemes de pose**  
**Systems of laying**

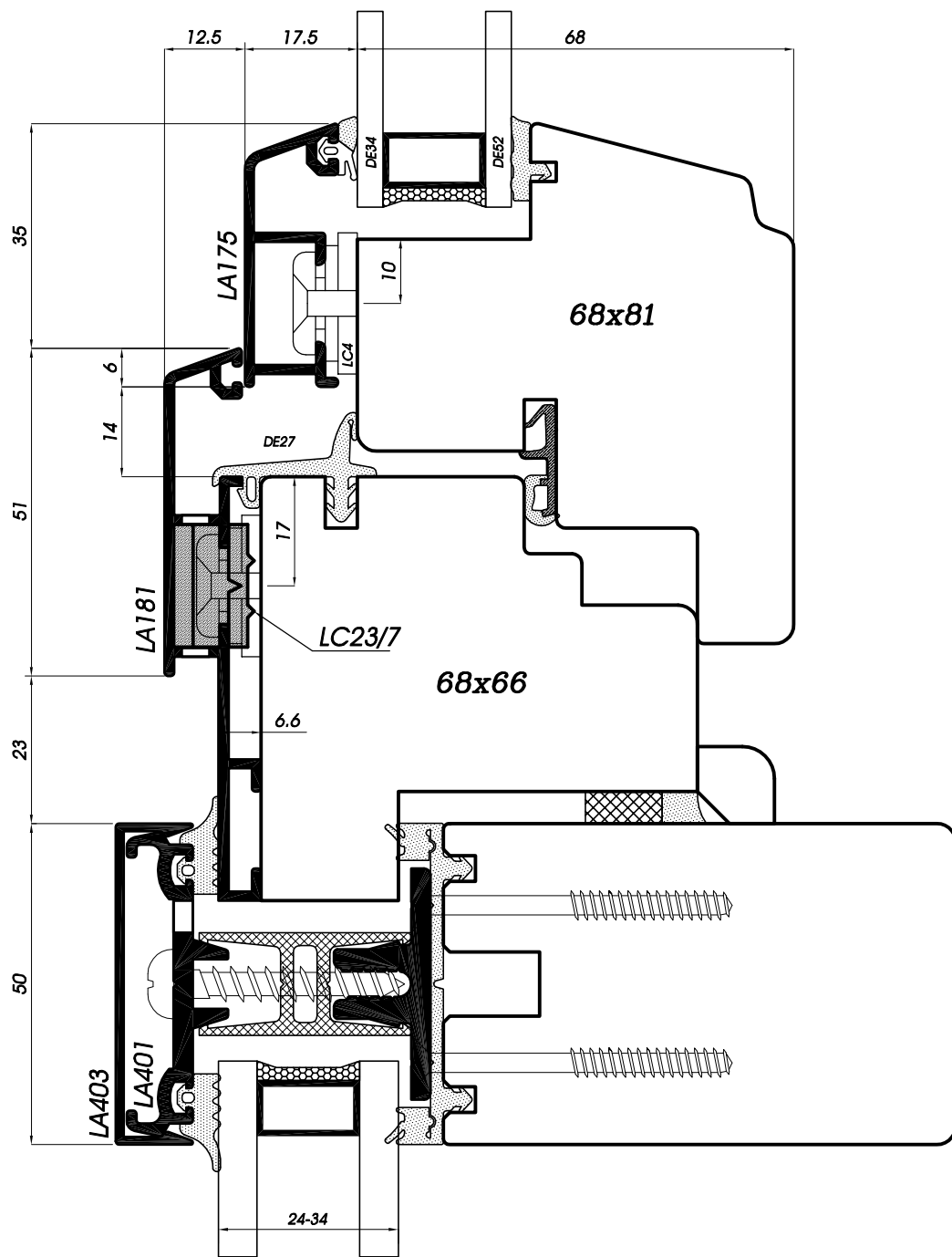

**ATTENZIONE:** Il profilo LA181 deve essere asolato a misura dopo aver tagliato il pezzo



Convogliatore per LA181  
LC23/7

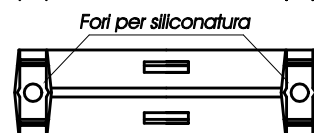
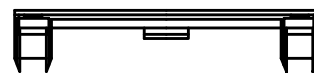

Sezione verticale traversi con facciata Unitherm  
Vertikalschnitt Fassade Unitherm - Riegel-  
Sección vertical travesaños con fachada Unitherm  
Coupe verticale des traverses avec façade Unitherm  
Vertical section of ledgers with Unitherm curtain wall

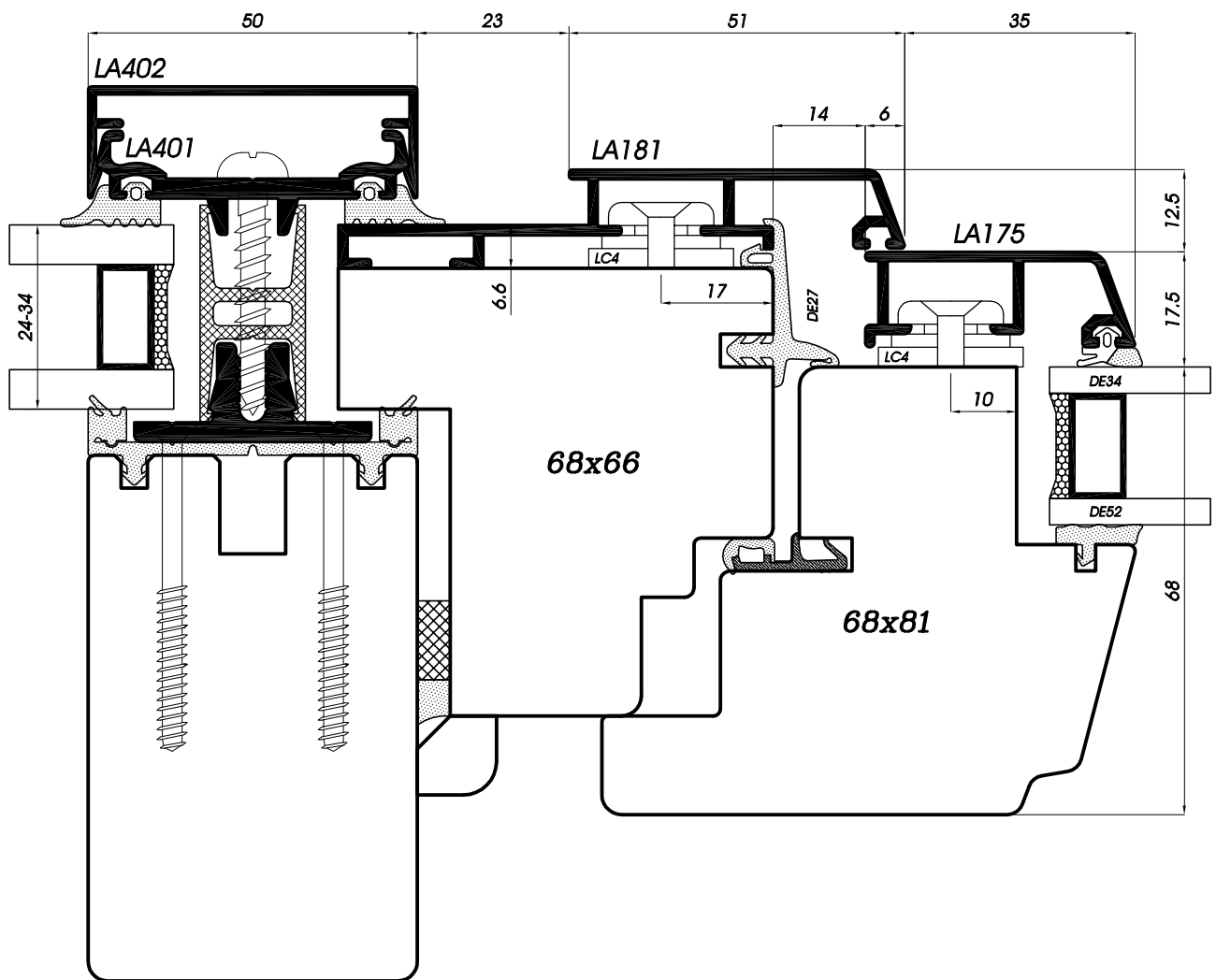

Sezione orizzontale montanti con facciata Unitherm  
 Horizontalschnitt Fassade Unitherm - Pfosten  
 Sección horizontal montantes con fachada Unitherm  
 Coupe horizontale des montants avec façade Unitherm  
 Vertical section of jambs with Unitherm curtain wall



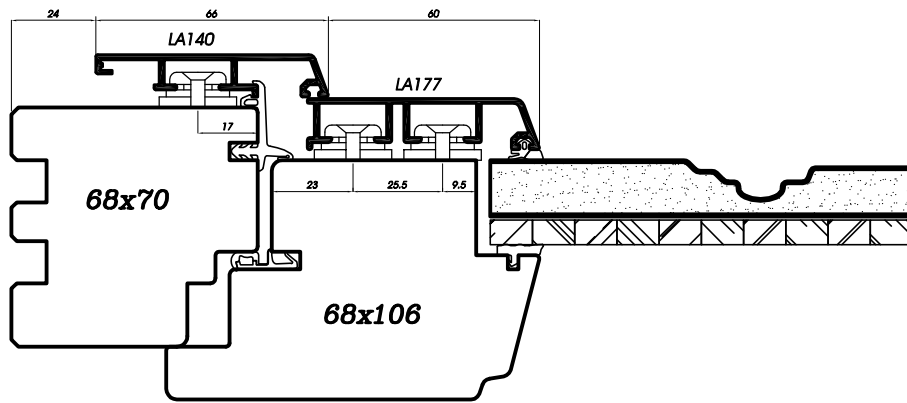

ALLUMINIO VERNICIATO SP. 12/10

LEGNO MDF

PANNELLO DI MULTISTRATI  
O LEGNO MASSELLO

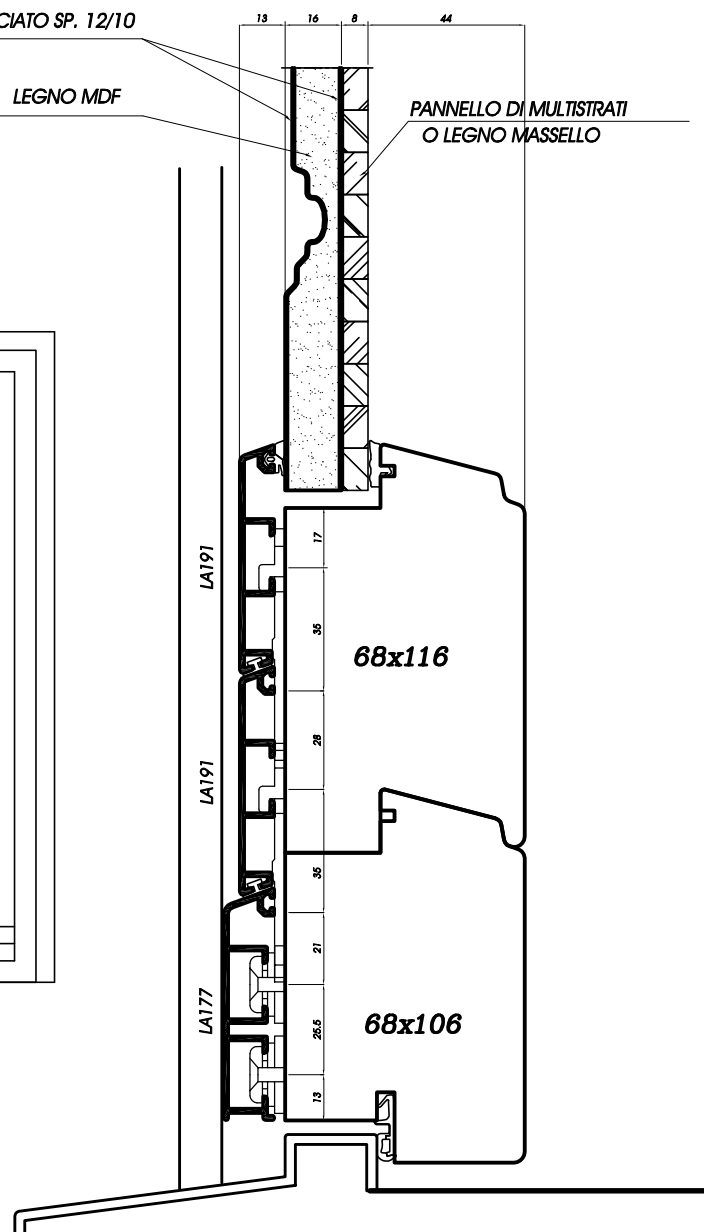
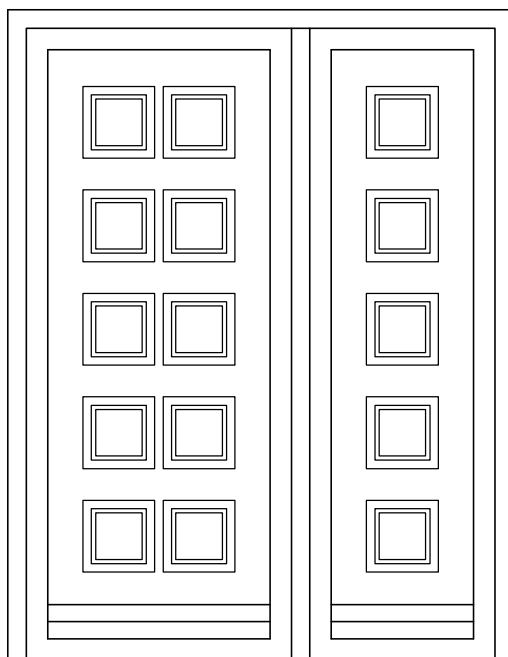

Portoncini d'ingresso con pannelli in MDF bugnato con lamiera in alluminio 12/10  
 Eingangstür mit Füllung MDF profiliert und mit Alublech 12/10 überzogen  
 Puerta de entrada con panel en MDF almohadillado con chapa de aluminio 12/10  
 Portes d'entrée avec panneau en MDF recouvert d'une tôle aluminium 12/10 profilé  
 Little main doors with panels in MDF raised with aluminum sheet 12/10

**PANNELLO SPESSORE 16 mm**

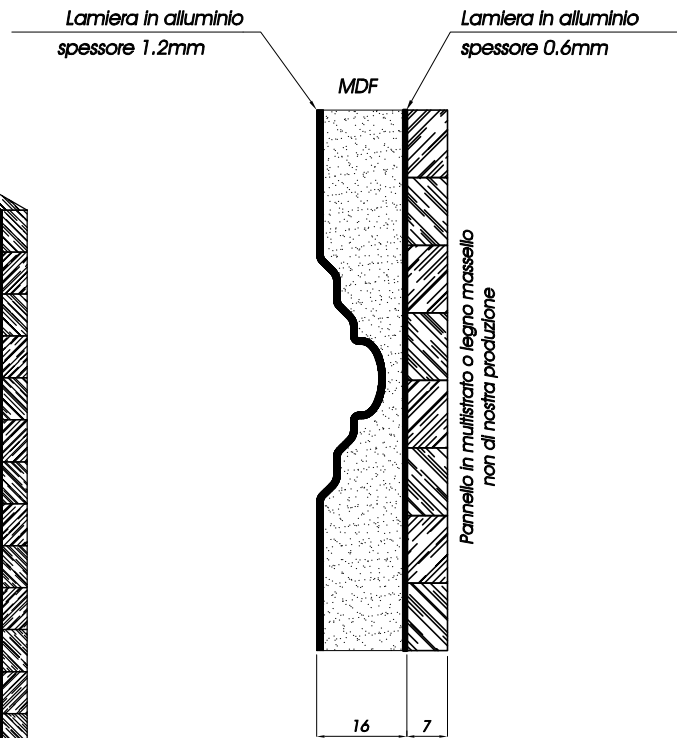
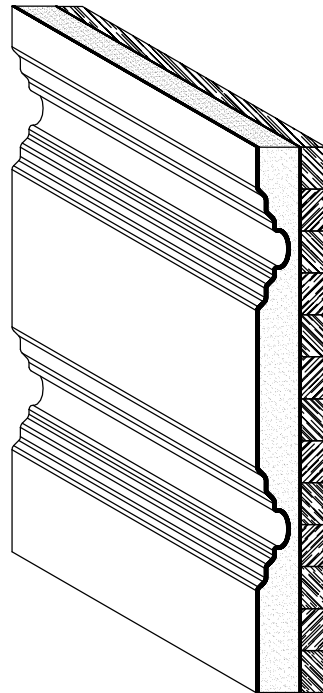

**PANNELLO SPESSORE 16 mm CON VETRO**

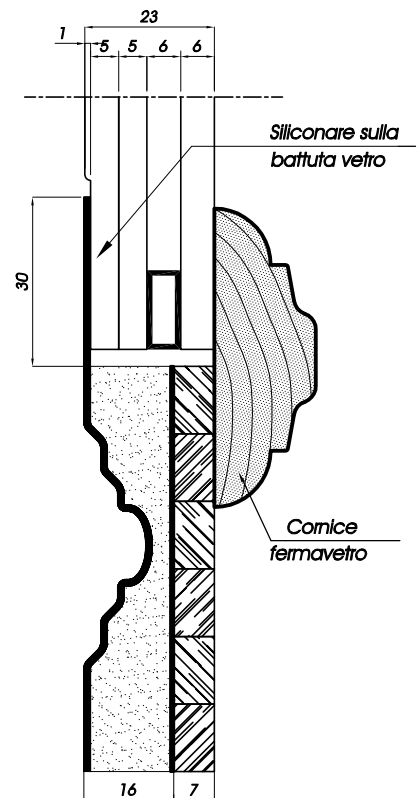
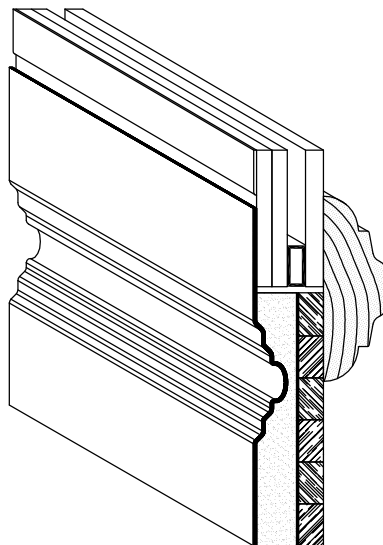

Portoncini d'ingresso - *Composizione dei pannelli*  
 Eingangstür - *Struktur der Paneele*  
 Puertas de entrada - *Composición de los paneles*  
 Portes d'entrée - *structure des panneaux*  
 Little main doors - *Panels composition*

(predisposto al vetro)

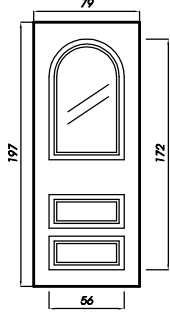

Camaby art. 955

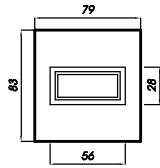

Camaby art. 830

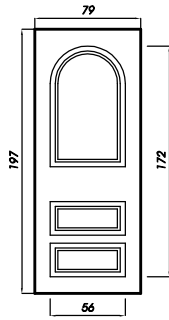

Camaby art. 950

Camaby art. 910

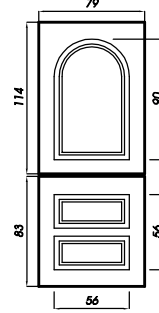

Camaby art. 820

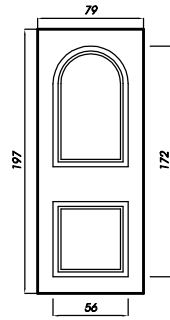

Camaby art. 900

Camaby art. 910

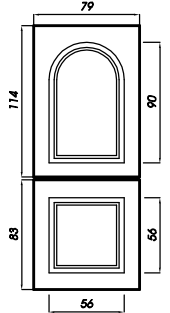

Camaby art. 920

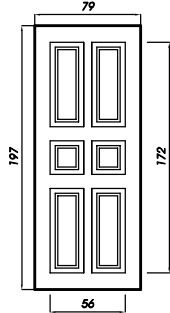

Manhattan art. 800

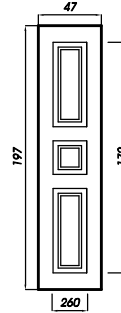

Pigalle art. 810

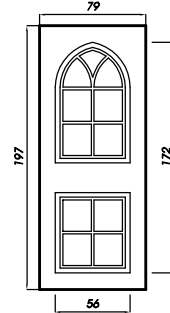

Rialto art. 700

Rialto art. 710

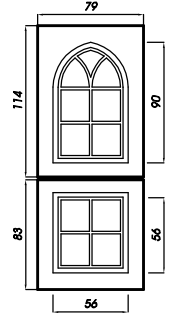

Rialto art. 720

(predisposto al vetro)

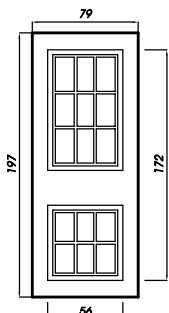

Tamigi art. 550

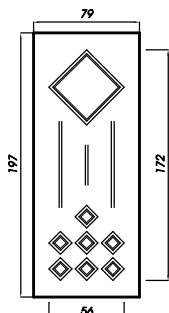

Trocadero art. 650

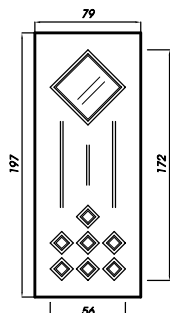

Trocadero art. 655

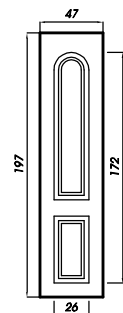

Piccadilly art. 880

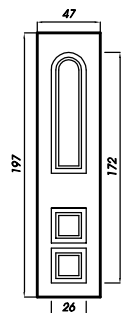

Camaby art. 980

Camaby art. 990

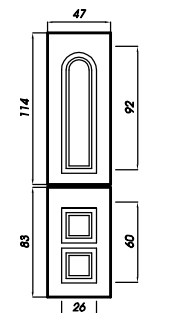

Rio art. 370

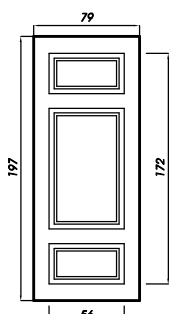

Oxford art. 530

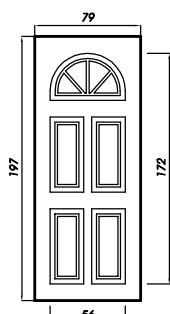

Montparnasse art. 750

(predisposto al vetro)

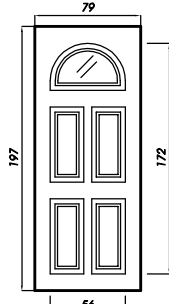

Montparnasse art. 755

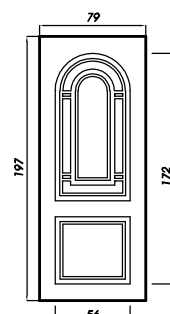

Piccadilly art. 850

(predisposto al vetro)

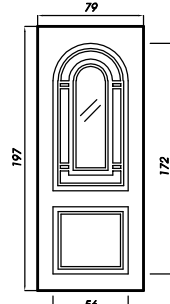

Piccadilly art. 855

Portoncini d'ingresso - Tipologie dei pannelli  
Verschiedene Füllungen für Eingangstüren  
Puertas de entrada - Tipologías de los paneles  
Gamme des panneaux pour portes d'entrée  
Little main doors - Kinds of Panel

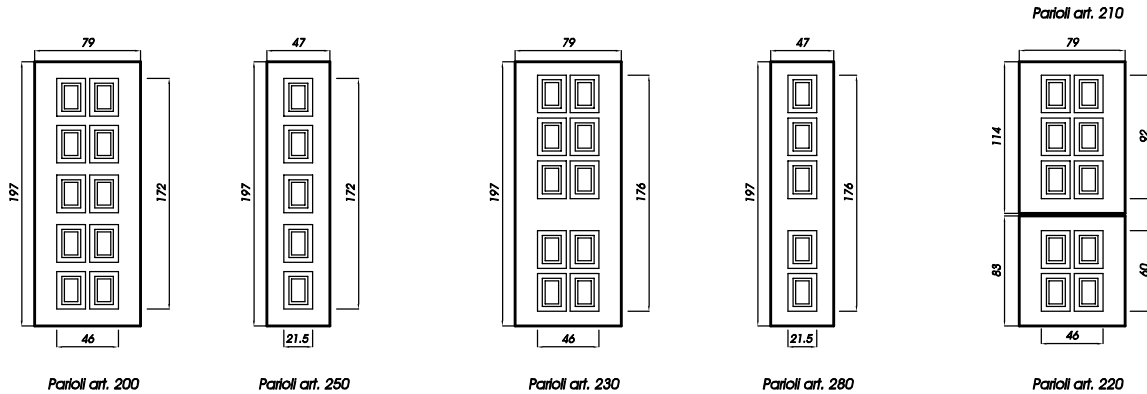

Parioli art. 200

Parioli art. 250

Parioli art. 230

Parioli art. 280

Parioli art. 210

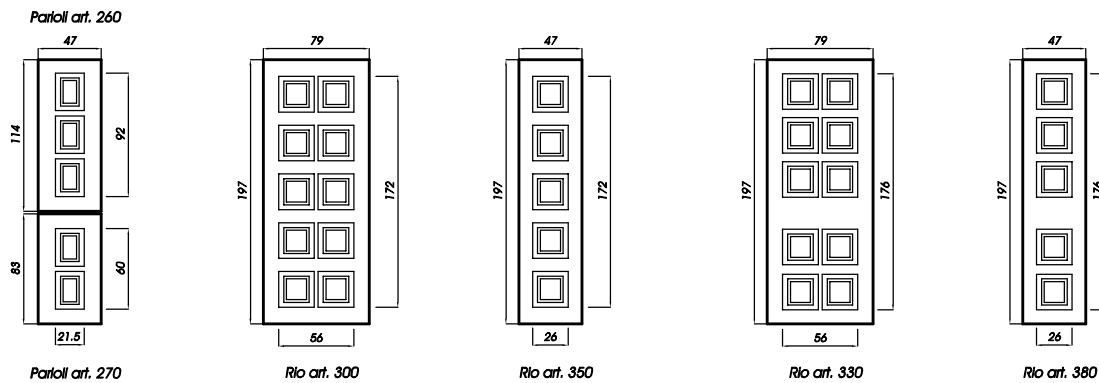

Parioli art. 260

Rio art. 300

Rio art. 350

Rio art. 330

Rio art. 380

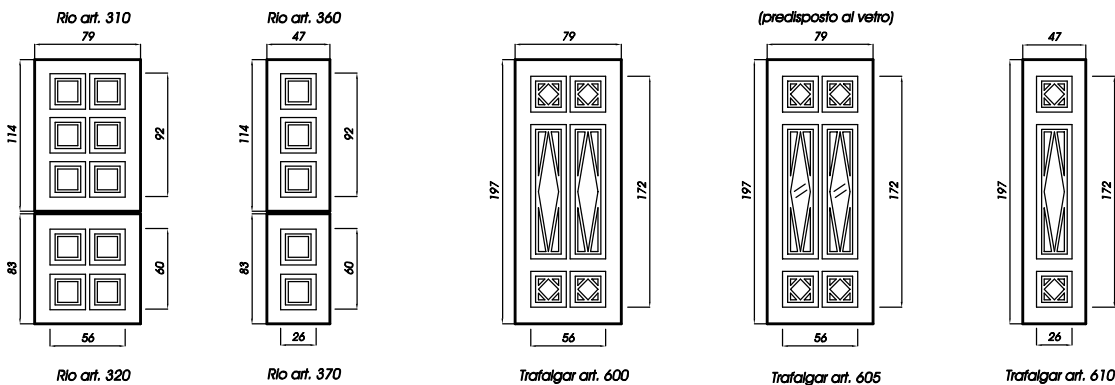

Rio art. 310

Rio art. 360

Trafalgar art. 600

Trafalgar art. 605

Trafalgar art. 610

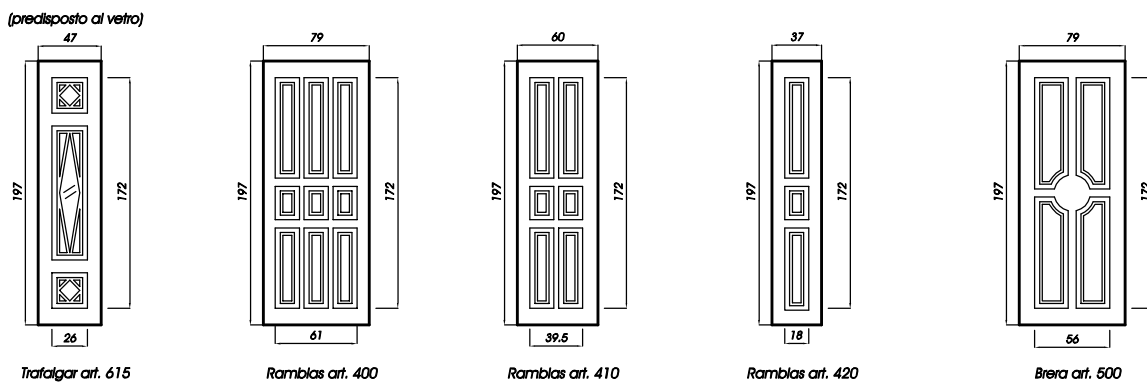

(predisposto al vetro)

Trafalgar art. 615

Rambblas art. 400

Rambblas art. 410

Rambblas art. 420

Brera art. 500

Portoncini d'ingresso - Tipologie dei pannelli  
 Verschiedene Füllungen für Eingangstüren  
 Puertas de entrada - Tipologías de los paneles  
 Gamme des panneaux pour portes d'entrée  
 Little main doors - Kinds of Panel

# NUOVO SISTEMA PER PANNELLI BUGNATI

Nuovo sistema per la realizzazione e applicazione di pannelli bugnati su misura

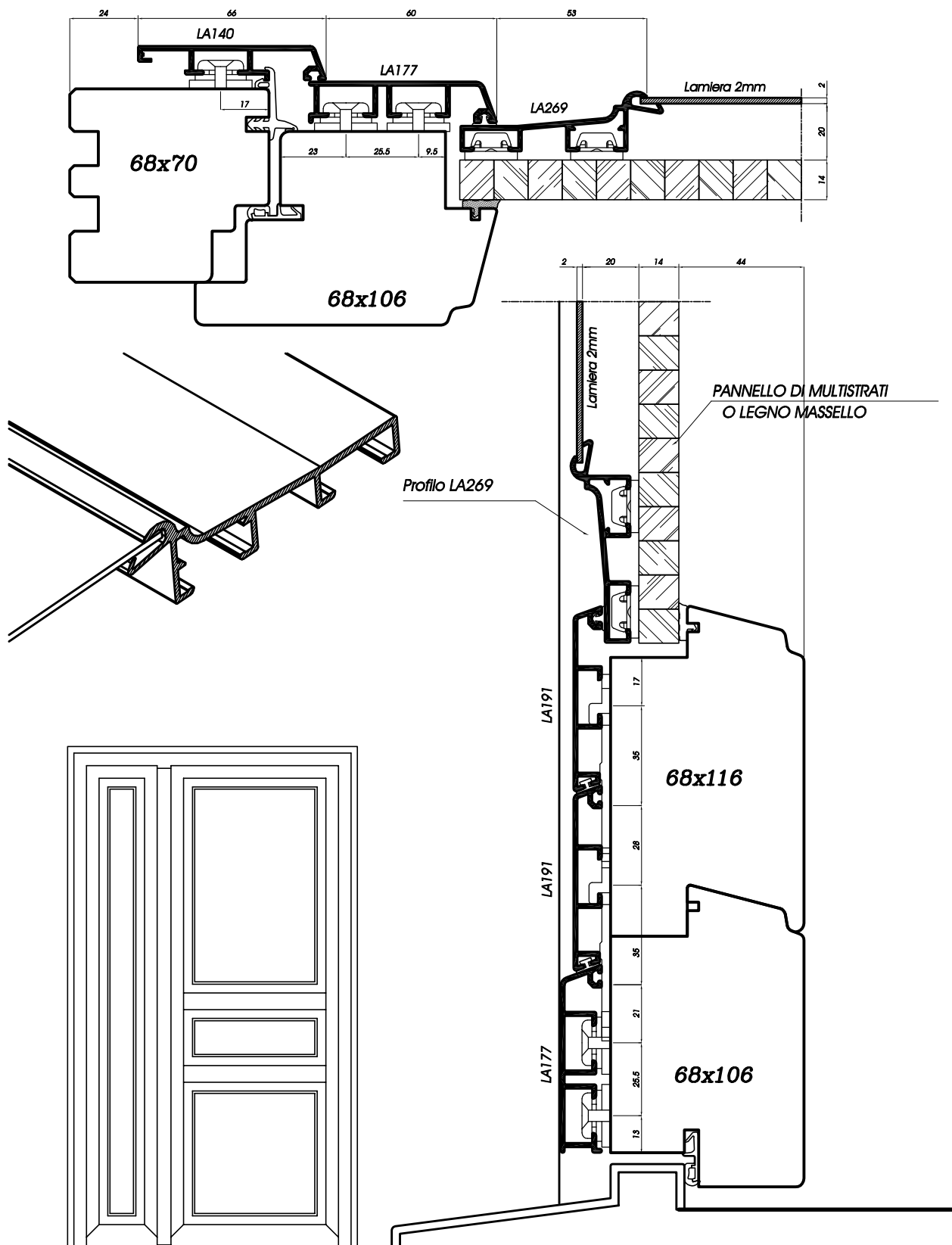

*Pannelli bugnati su misura con profilo LA269*  
*Profilierte Paneelen auf Mass mit Profil LA269*  
*Paneles almohadillados a medida con perfil LA269*  
*Panneaux moulurés sur mesure avec profil LA269*  
*Raised panels on size with profil LA269*

# NUOVO SISTEMA PER PANNELLI BUGNATI

Nuovo sistema per la realizzazione e applicazione di pannelli bugnati su misura

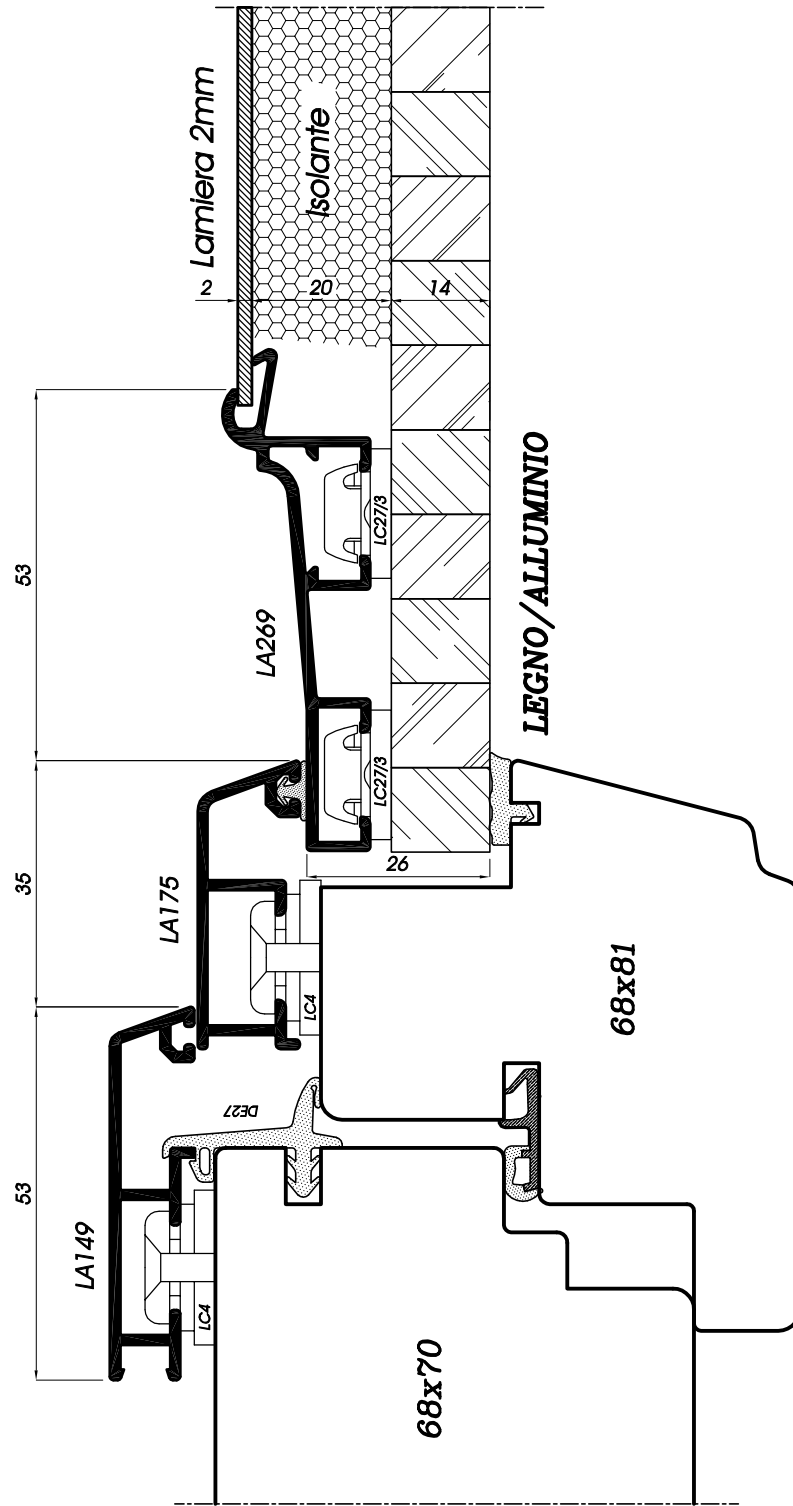

Pannelli bugnati su misura con profilo LA269  
Profilierte Paneelen auf Mass mit Profil LA269  
Paneles almohadillados a medida con perfil LA269  
Panneaux moulurés sur mesure avec profil LA269  
Raised panels on size with profil LA269

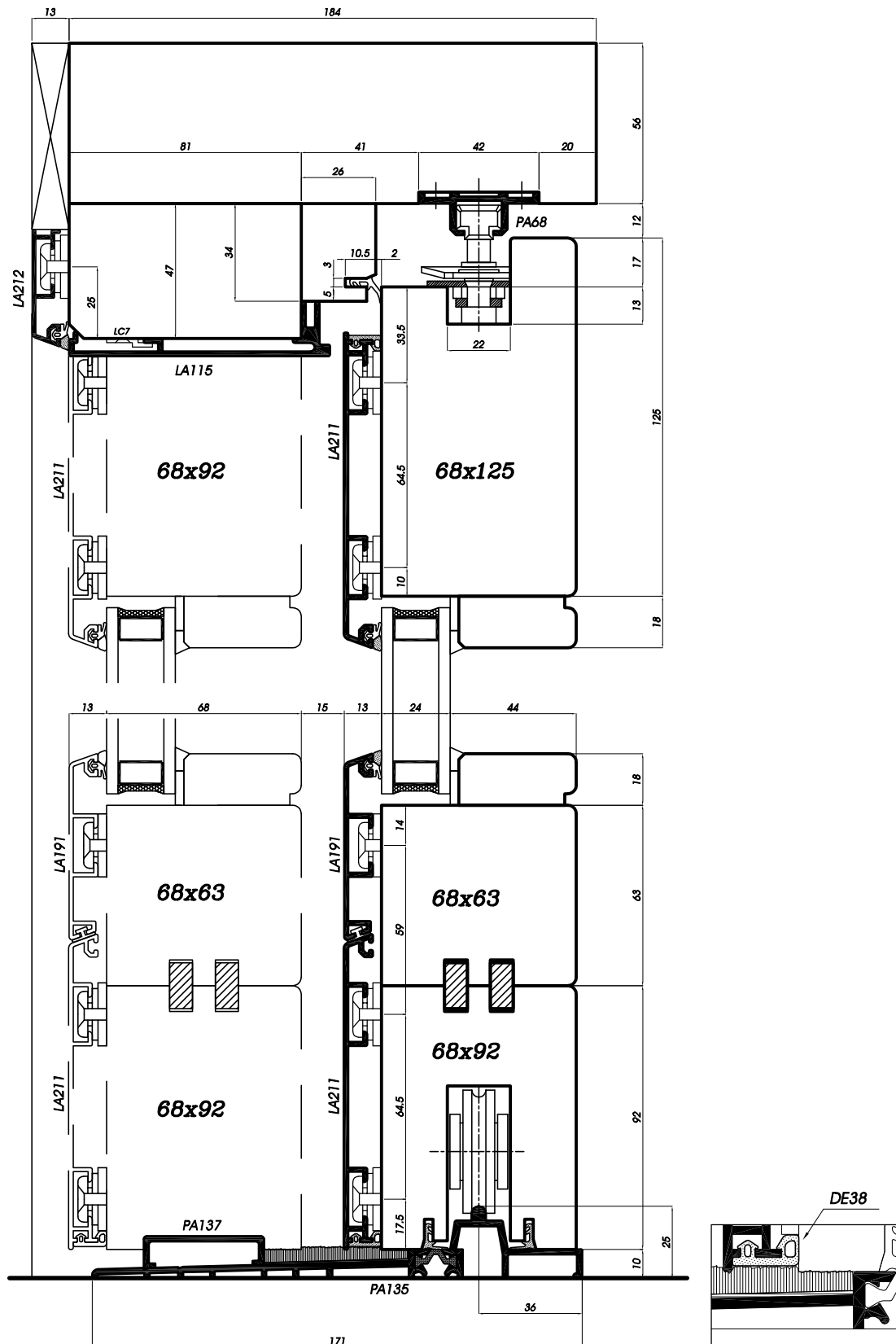

**Sezione verticale serramento alzante scorrevole sp.68mm con apertura a ribalta**  
**Vertikalschnitt Hebe-Schiebe-Tür Holzstärke 68mm mit Kippvorrichtung**  
**Sección vertical corredera elevadora con madera espesor 68mm con apertura oscilobatiente**  
**Coupe verticale fenêtre levante-coulissante-oscillante épaisseur 68mm**  
**Vertical section of sliding window-door with a thickness of 68 mm and overturning opening**

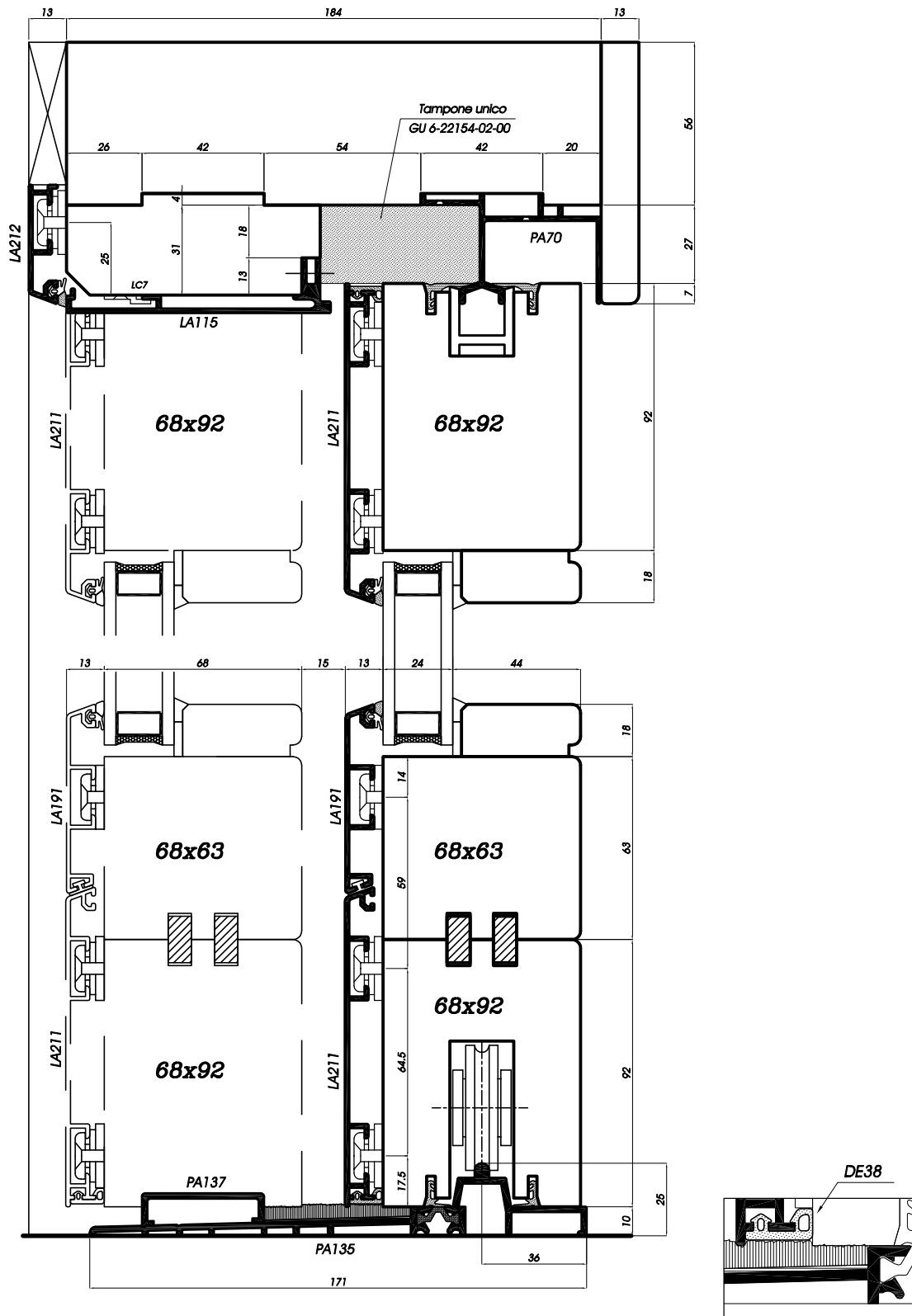

**Sezione verticale serramento alzante scorrevole sp.68mm**  
**Vertikalschnitt Hebe-Schiebe-Tür Holzstärke 68mm**  
**Sección vertical corredera elevadora con madera espesor 68mm**  
**Coupe verticale fenêtre levante-coulissante épaisseur 68mm**  
**Vertical section of sliding window-door with a thickness of 68 mm**



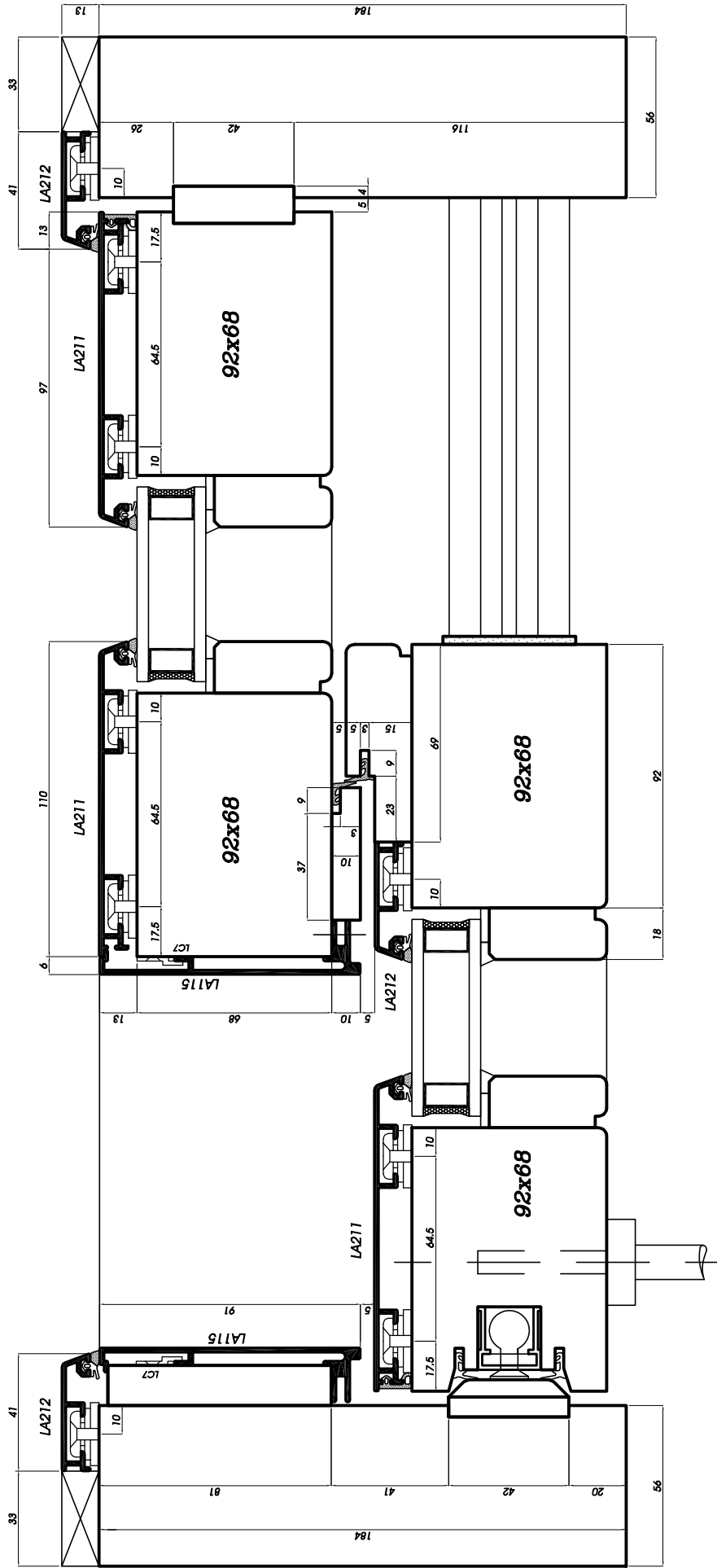

Sezione orizzontale serramento alzante scorrevole sp.68mm  
 Horizontalschnitt Hebe-Schiebe-Tür Holzstärke 68mm  
 Sección horizontal corredera elevadora con madera espesor 68mm  
 Coupe horizontale fenêtre levante-coulissante épaisseur 68mm  
 Horizontal section of sliding window-door with a thickness of 68 mm

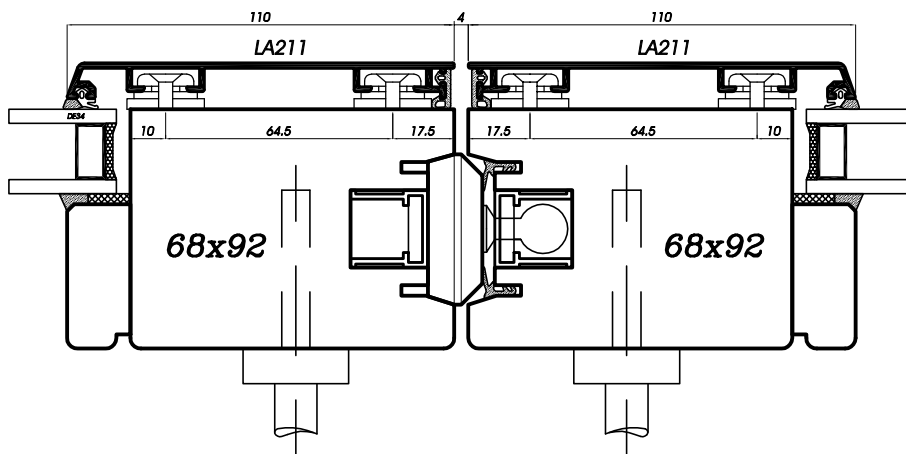
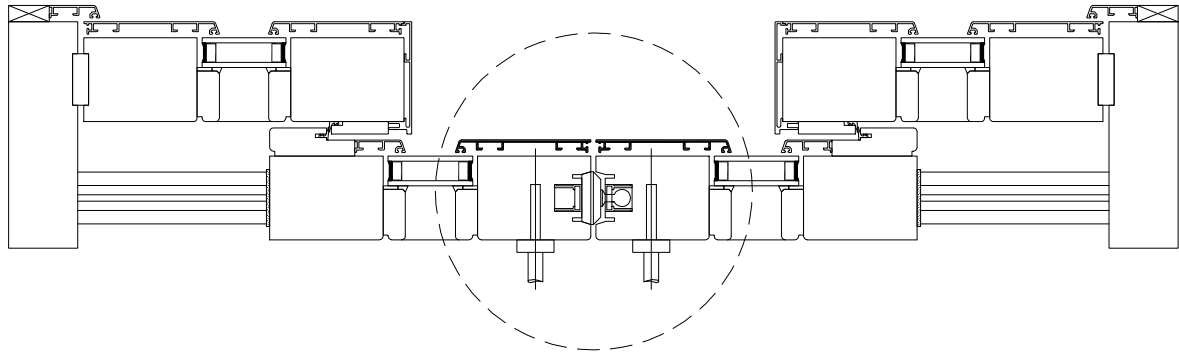

**Sezione orizzontale chiusura centrale serramento alzante scorrevole sp.68mm**  
**Horizontalschnitt Stulp Hebe-Schiebe-Tür Holzstärke 68mm**  
**Sección horizontal corredera elevadora con madera espesor 68mm**  
**Coupe horizontale battement central fenêtre levant-coulissante épaisseur 68 mm**  
**Horizontal middle clamp's section of the sliding window-door with a thickness of 68 mm**

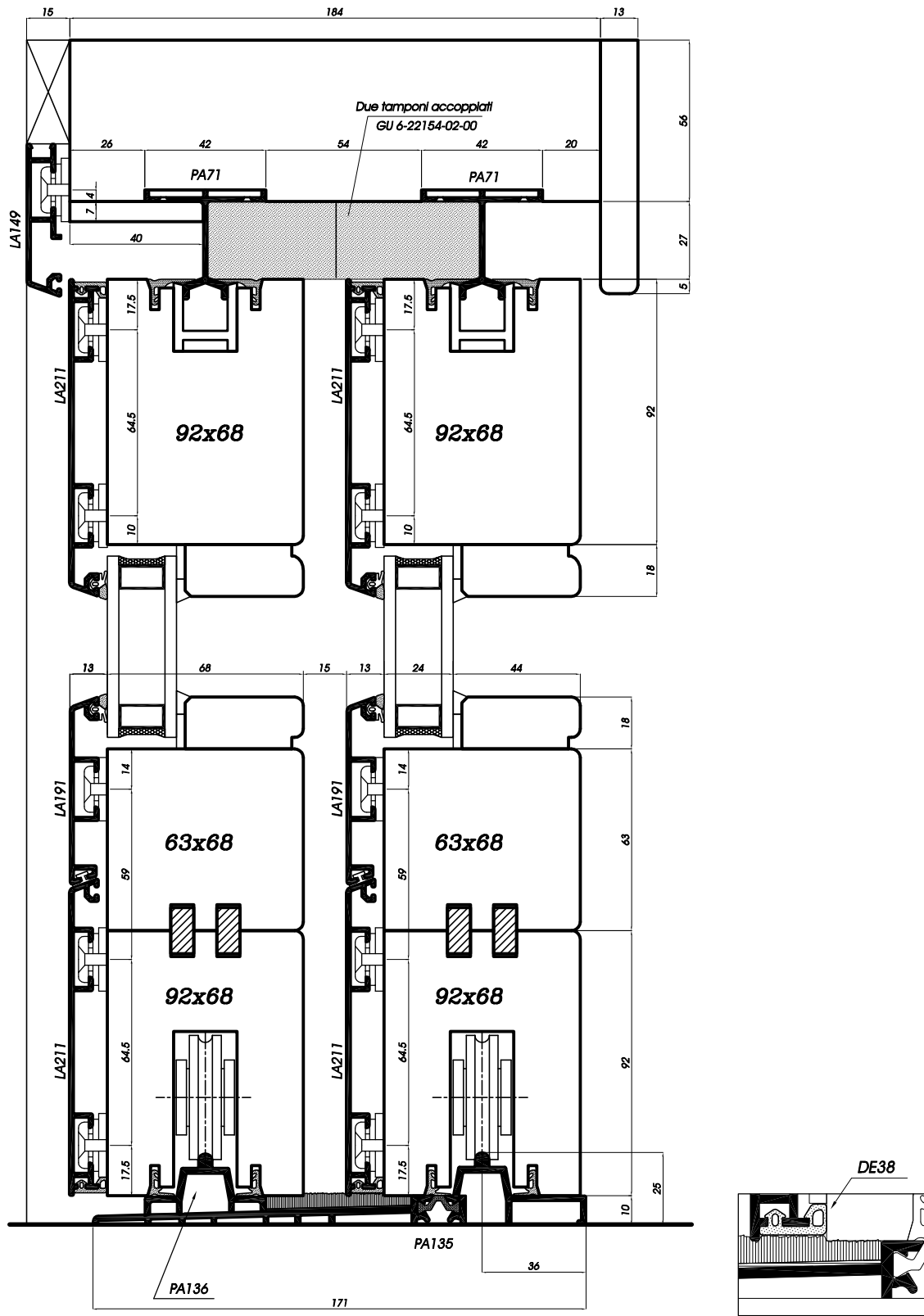

**Sezione verticale serramento alzante scorrevole sp.68mm con doppia anta mobile**  
**Vertikalschnitt Hebe-Schiebe-Tür, zwei-flügelig, Holzstärke 68mm**  
**Sección vertical corredera elevadora con madera espesor 68mm con doble hoja practicable**  
**Coupe verticale fenêtre levant-coulissante épaisseur 68 mm - 2 vantaux mobiles**  
**Vertical section of the sliding window-door with a thickness of 68 mm and a double mobile wing**

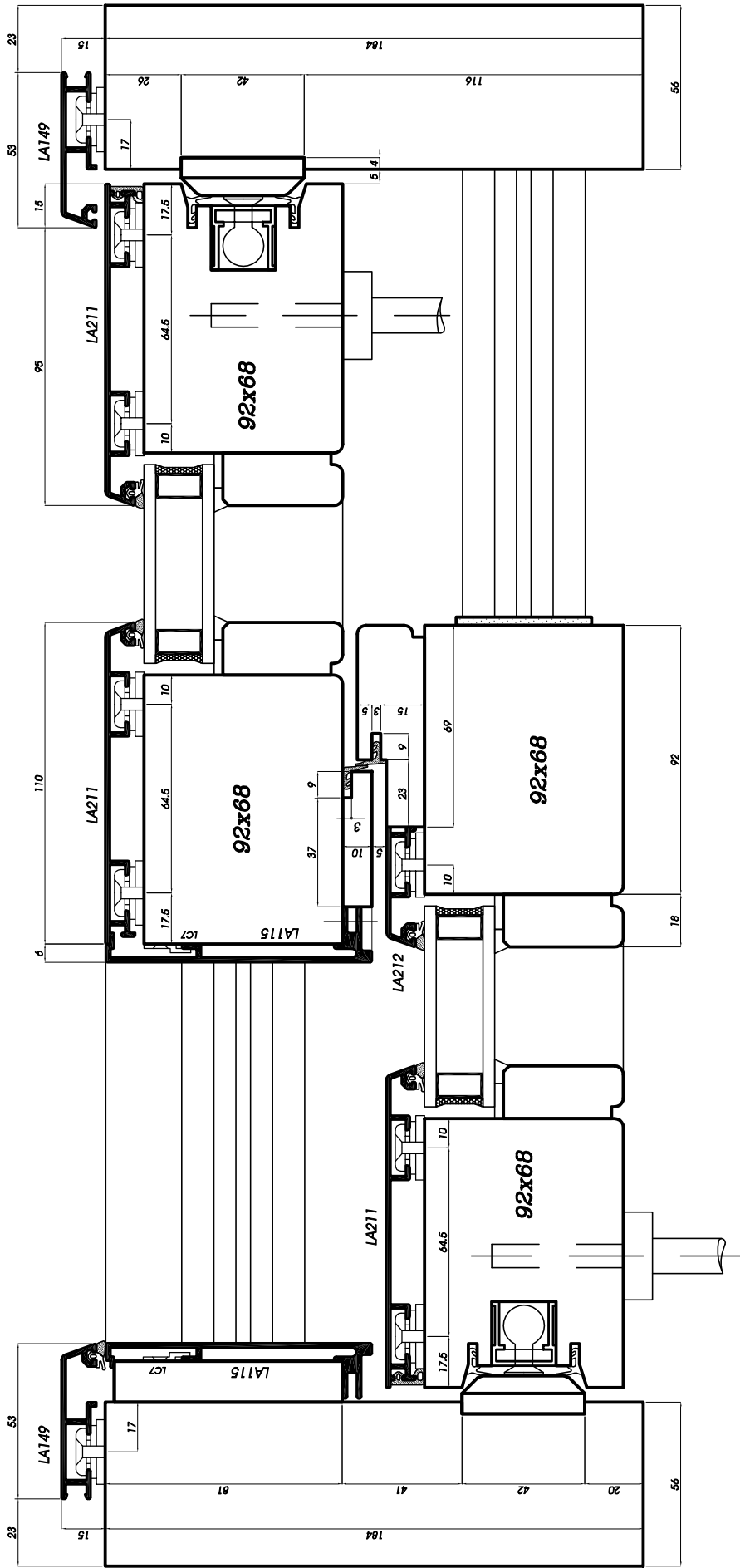

Sezione orizzontale serramento alzante scorrevole sp.68mm con doppia anta mobile  
 Horizontalschnitt Hebe-Schiebe-Tür, 2-flg., Holzstärke 68mm  
 Sección horizontal corredera elevadora con madera espesor 68mm con doble hoja practicable  
 Coupe horizontale fenêtre levant-coulissante épaisseur 68 mm - 2 vantaux mobiles  
 Horizontal section of the sliding window-door with a thickness of 68 mm and a double mobile wing

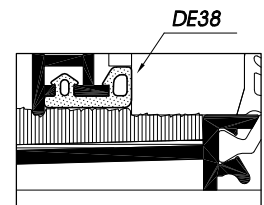
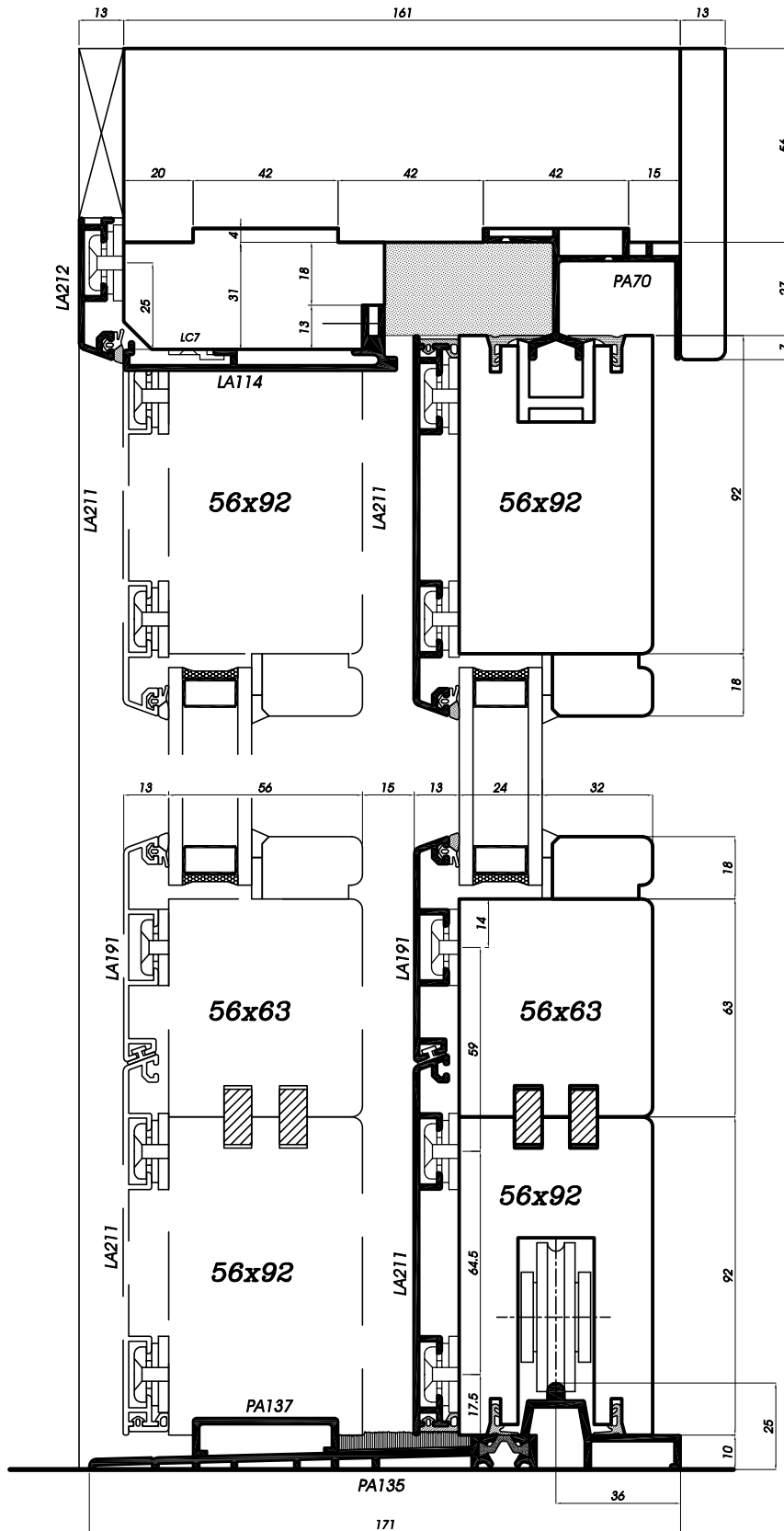

Sezione verticale serramento alzante scorrevole sp.56mm  
 Vertikalschnitt Hebe-Schiebe-Tür Holzstärke 56mm  
 Sección vertical corredera elevadora con madera espesor 56mm  
 Coupe verticale fenêtre levante-coulissante épaisseur 56mm  
 Vertical section of the sliding window-door with a thickness of 56mm

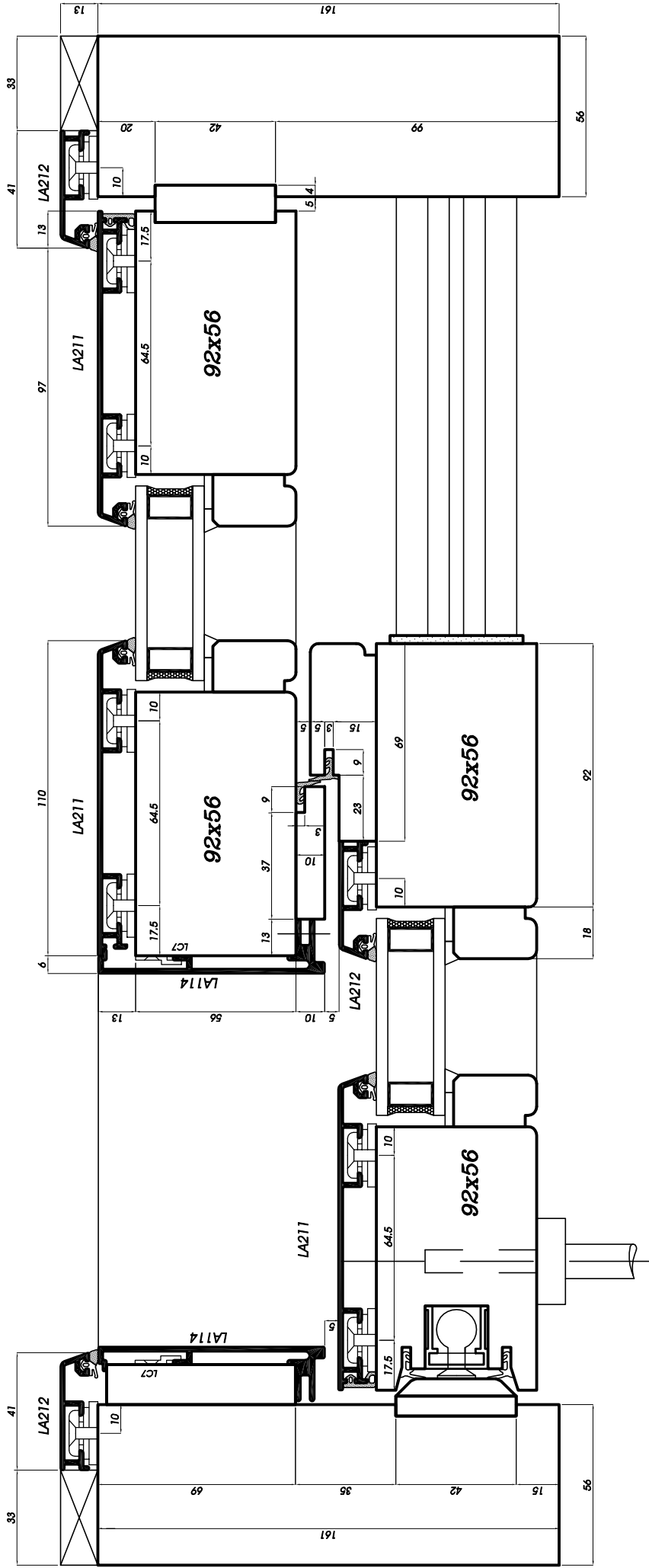

**Sezione orizzontale serramento alzante scorrevole sp.56mm**  
**Horizontalschnitt Hebe-Schiebe-Tür Holzstärke 56mm**  
**Sección horizontal corredera elevadora con madera espesor 56mm**  
**Coupe horizontale fenêtre levante-coulissante épaisseur 56mm**  
**Horizontal section of the sliding window-door with a thickness of 56mm**

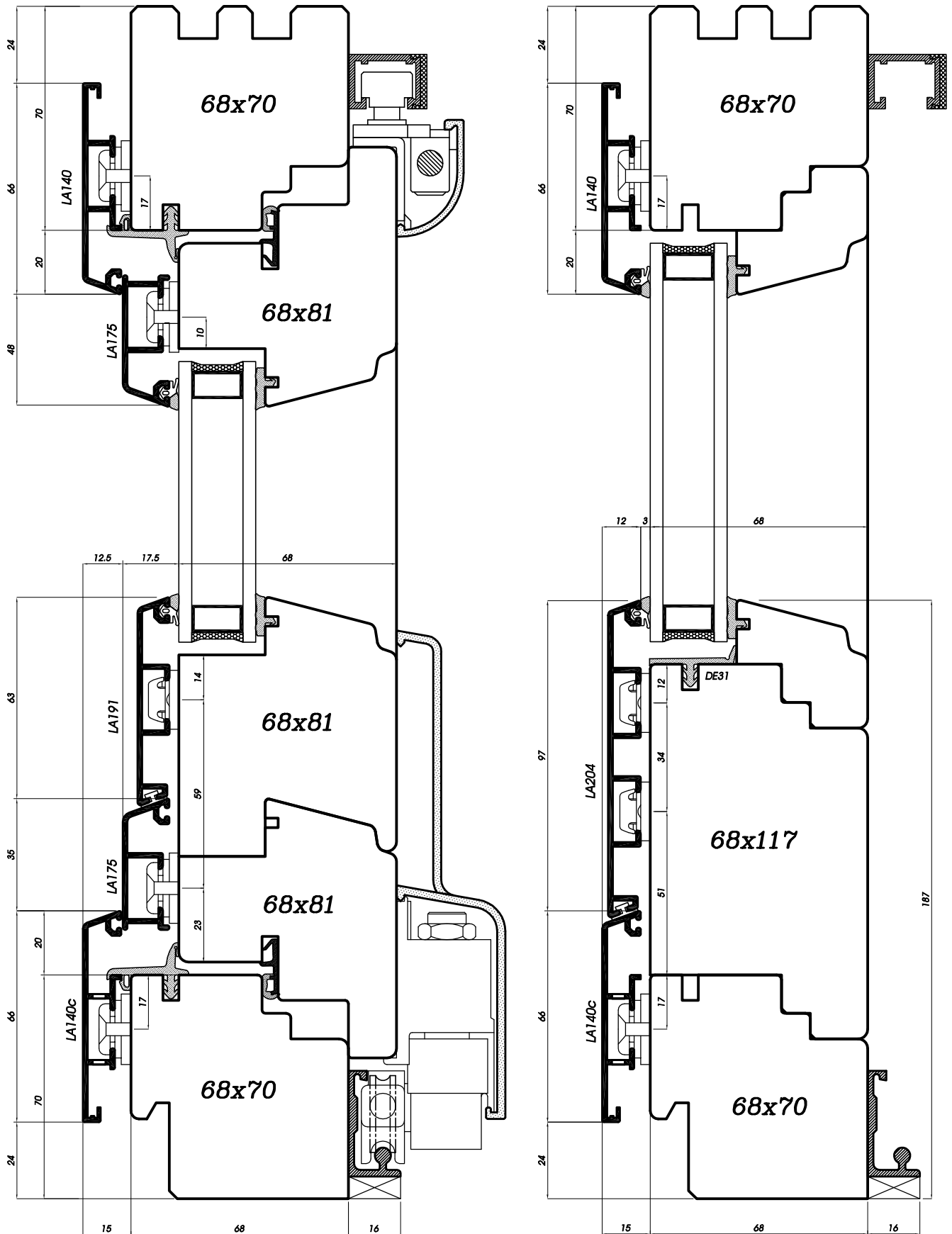

Sezione verticale portafinestra con scorrevole parallelo  
 Vertikalschnitt Parallelschiebekipptür  
 Sección vertical puertaventana con corredera paralela  
 Coupe verticale porte-fenêtre coulissante à translation  
 Vertical section of the parallel sliding window-door

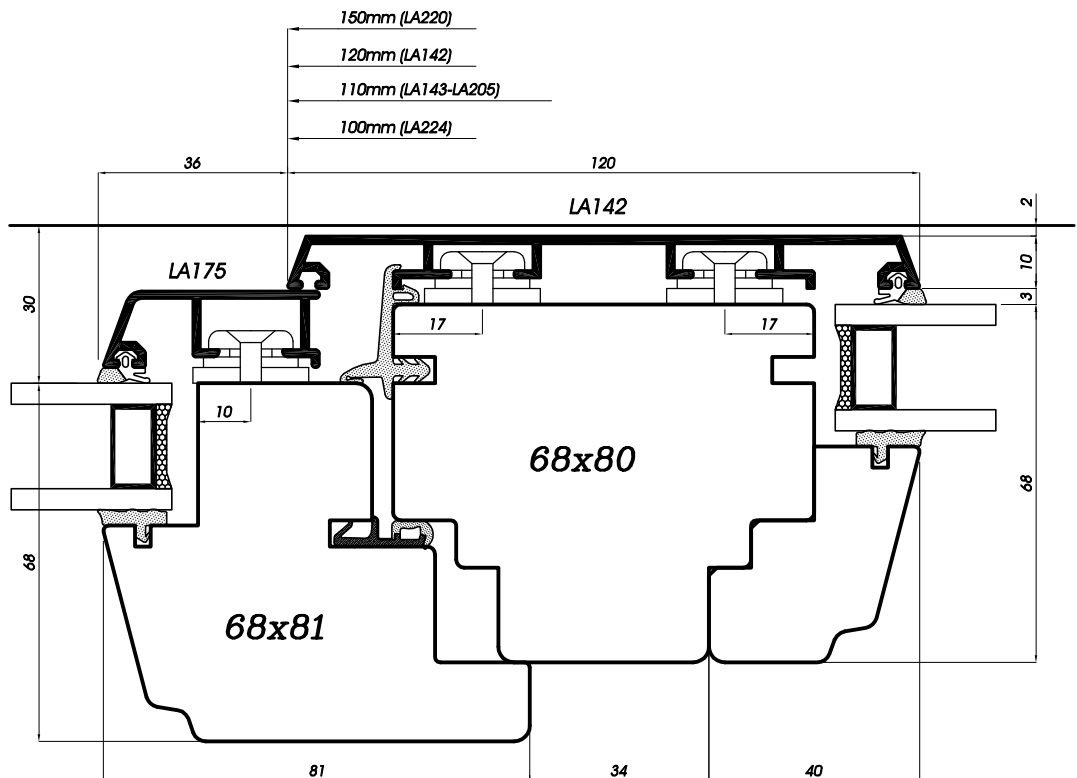
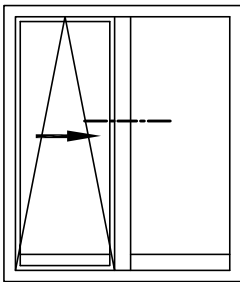
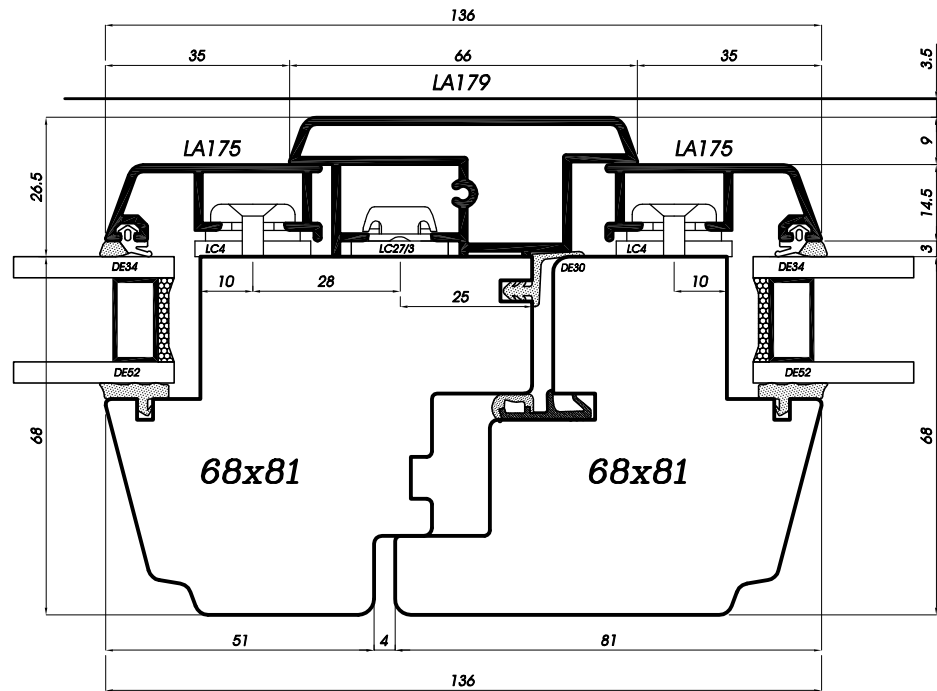
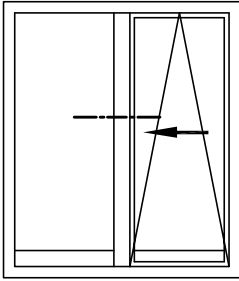

**Sezione orizzontale portafinestra con scorrevole parallelo**  
**Horizontalschnitt Parallelschiebekipptür**  
**Sección horizontal puertaventana con corredera paralela**  
**Coupe horizontale porte-fenêtre coulissante à translation**  
**Horizontal section of the parallel sliding window-door**



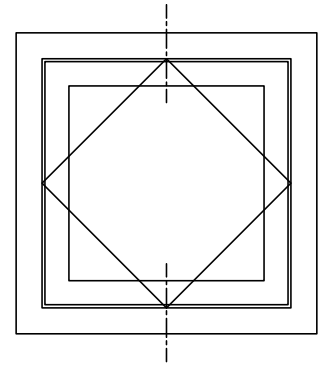
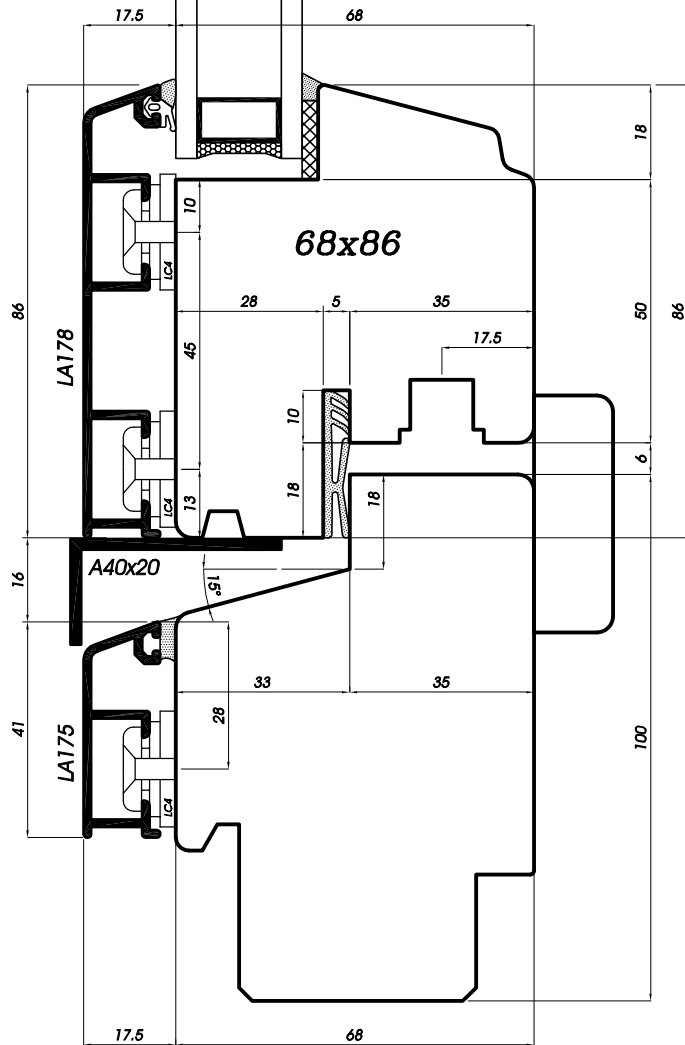
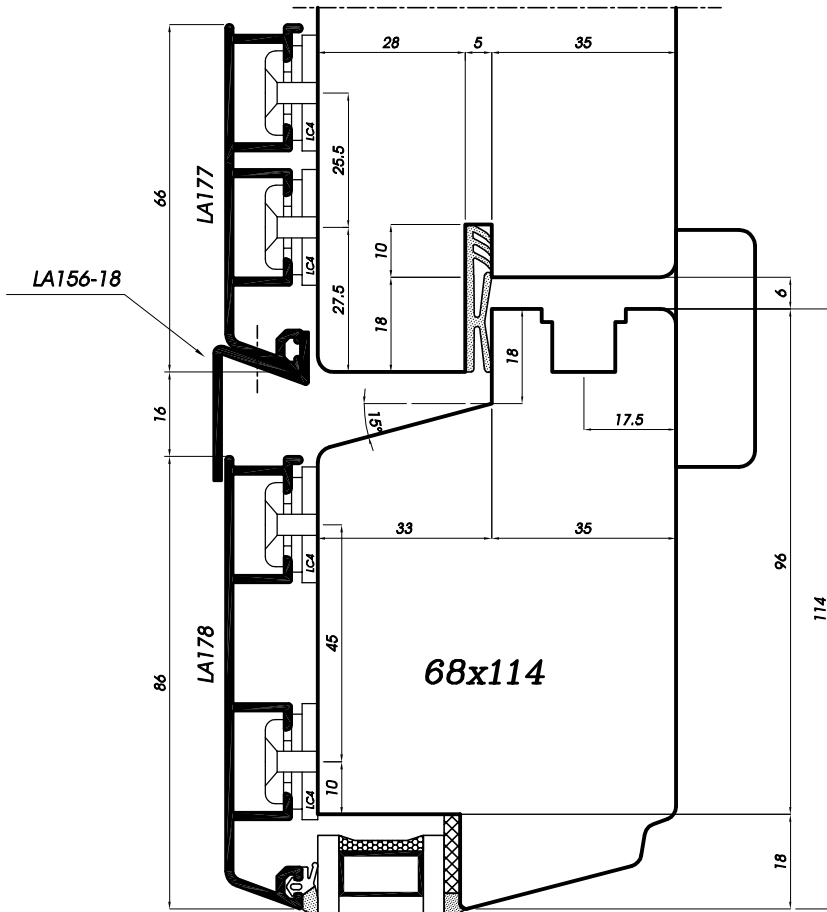

Sezione verticale bilico orizzontale  
 Vertikalschnitt Schwingflügel  
 Sección vertical de basculante horizontal  
 Coupe verticale fenêtre basculante  
 Vertical section of the horizontal bascule window

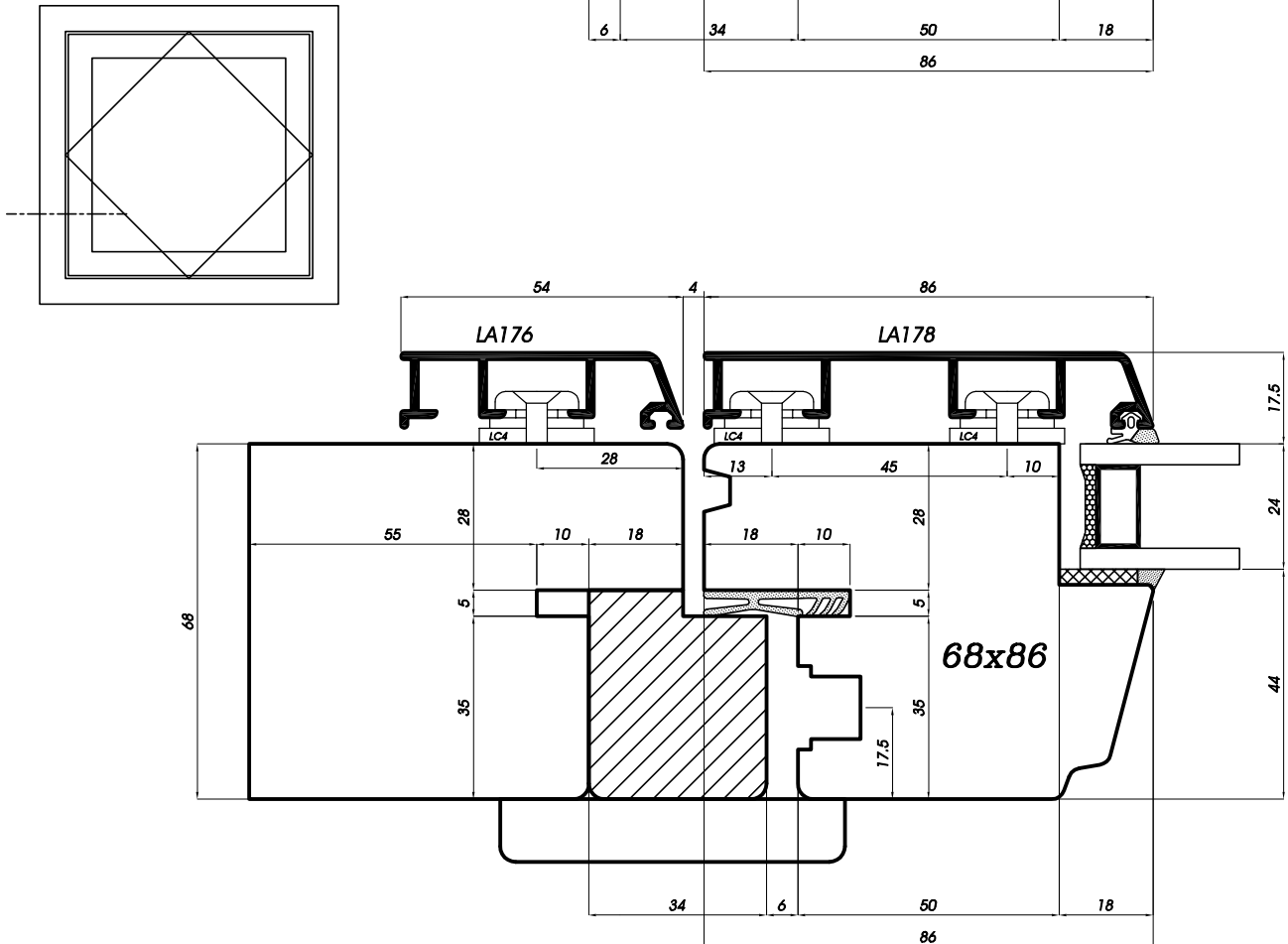
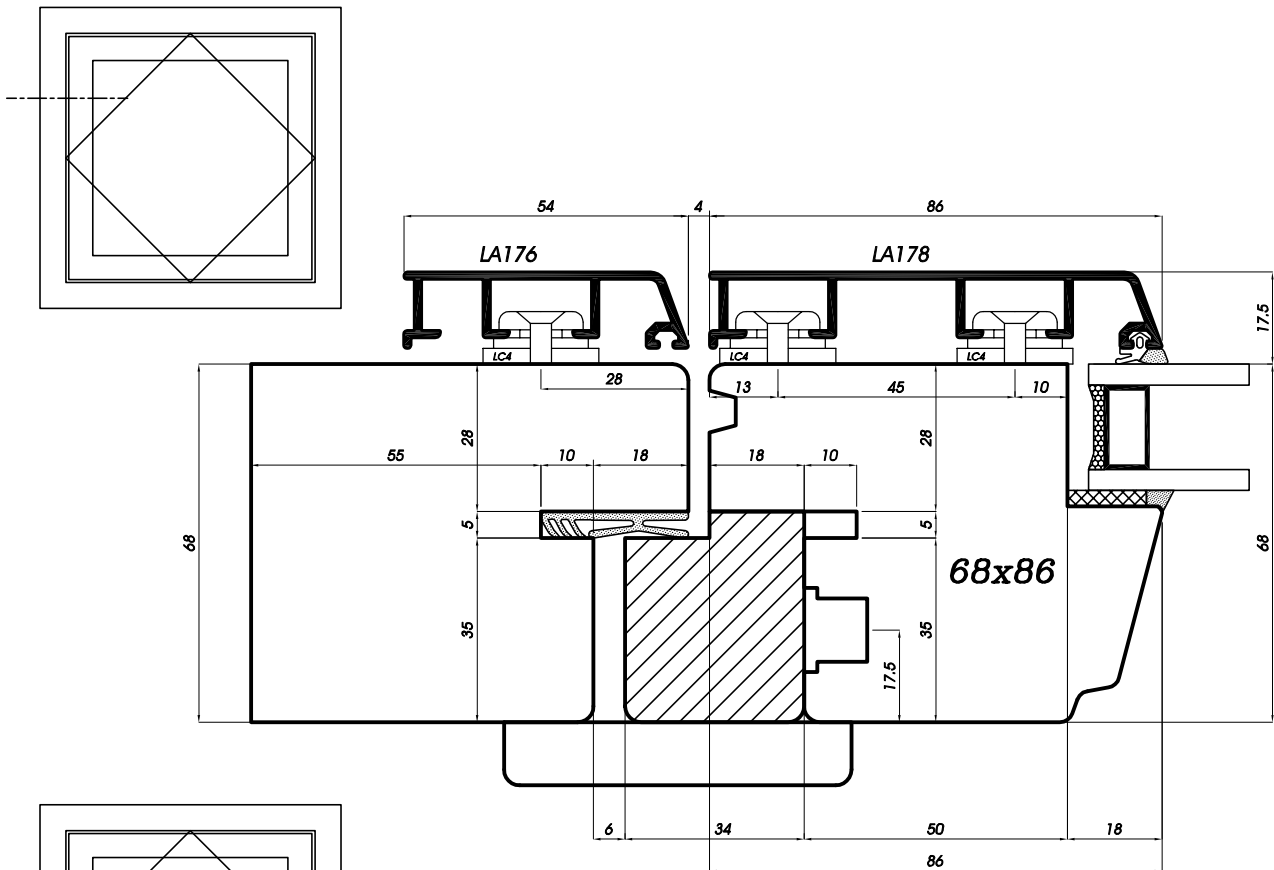

**Sezione orizzontale bilico orizzontale**  
**Horizontalschnitt Schwingflügel**  
**Sección horizontal de basculante horizontal**  
**Coupe horizontale fenêtre basculante**  
**Horizontal section of the horizontal bascule window**

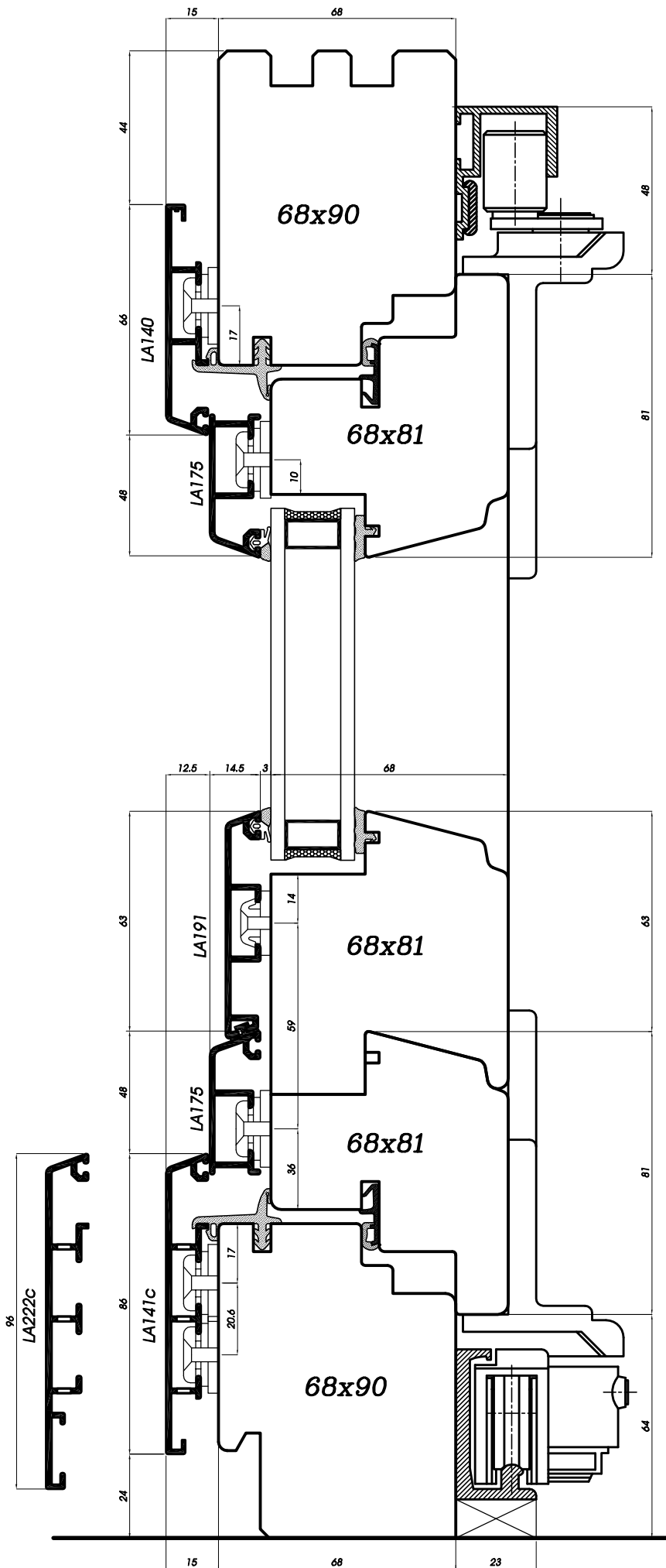

Sezione verticale serramento a libro  
 Vertikalschnitt Falttür  
 Sección vertical de cerramiento a libro  
 Coupe verticale fenêtre coulissante pliante  
 Vertical section of the sliding-folding window

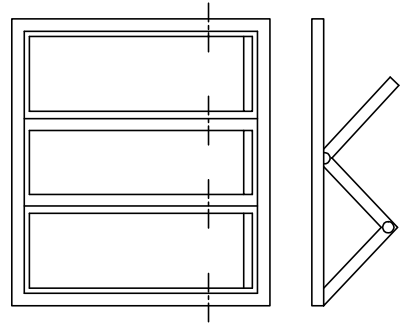
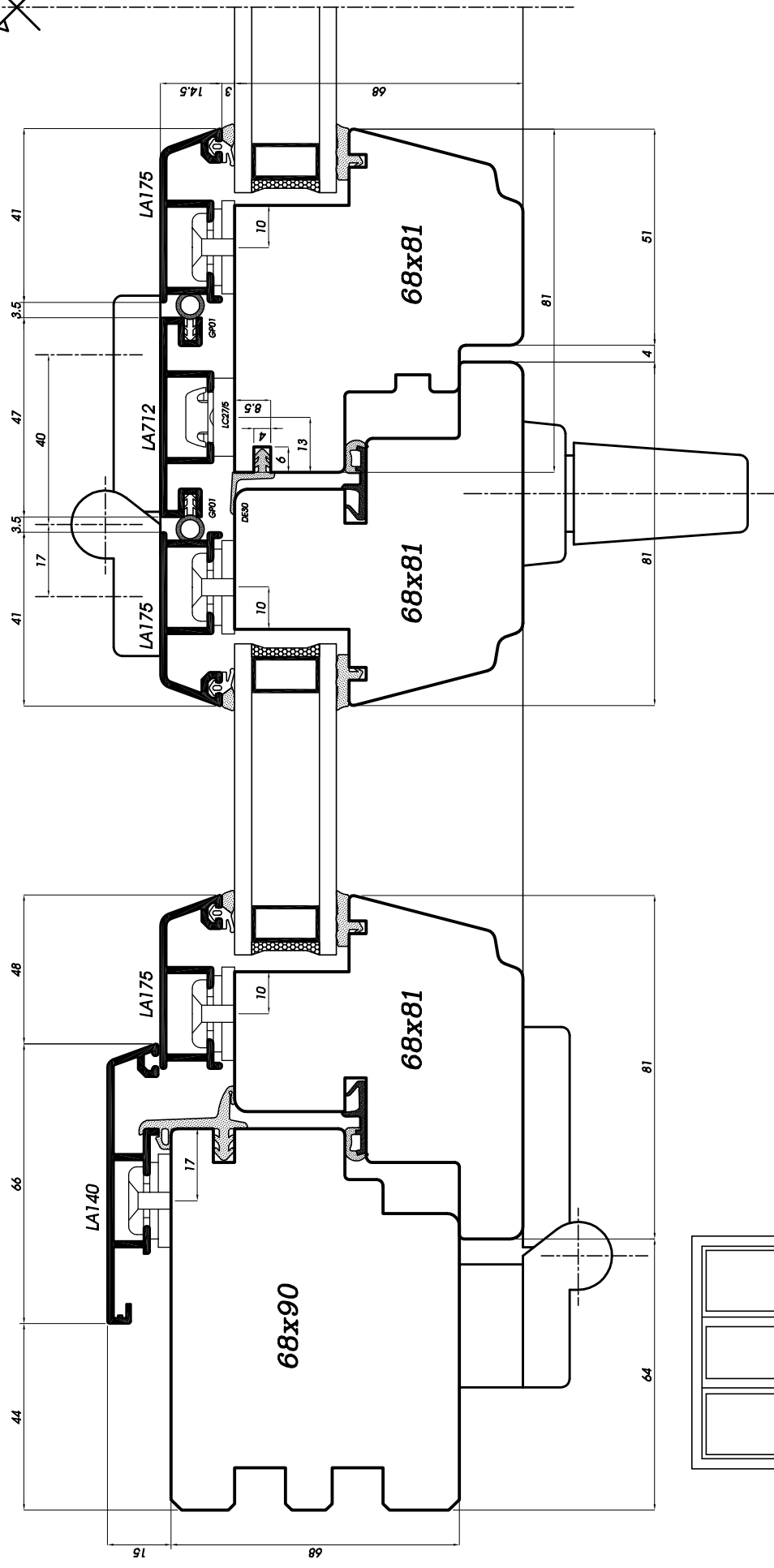
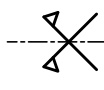

Sezione orizzontale serramento a libro  
Horizontalschnitt Falttür  
Sección horizontal de cerramiento a libro  
Coupe horizontale fenêtre coulissante pliante  
Vertical section of the sliding-folding window

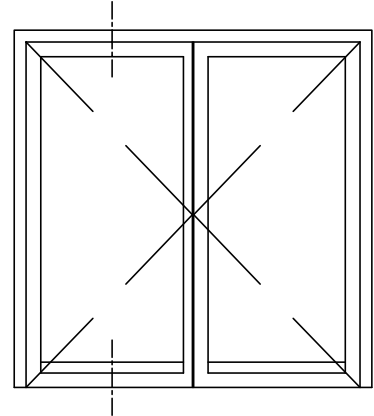
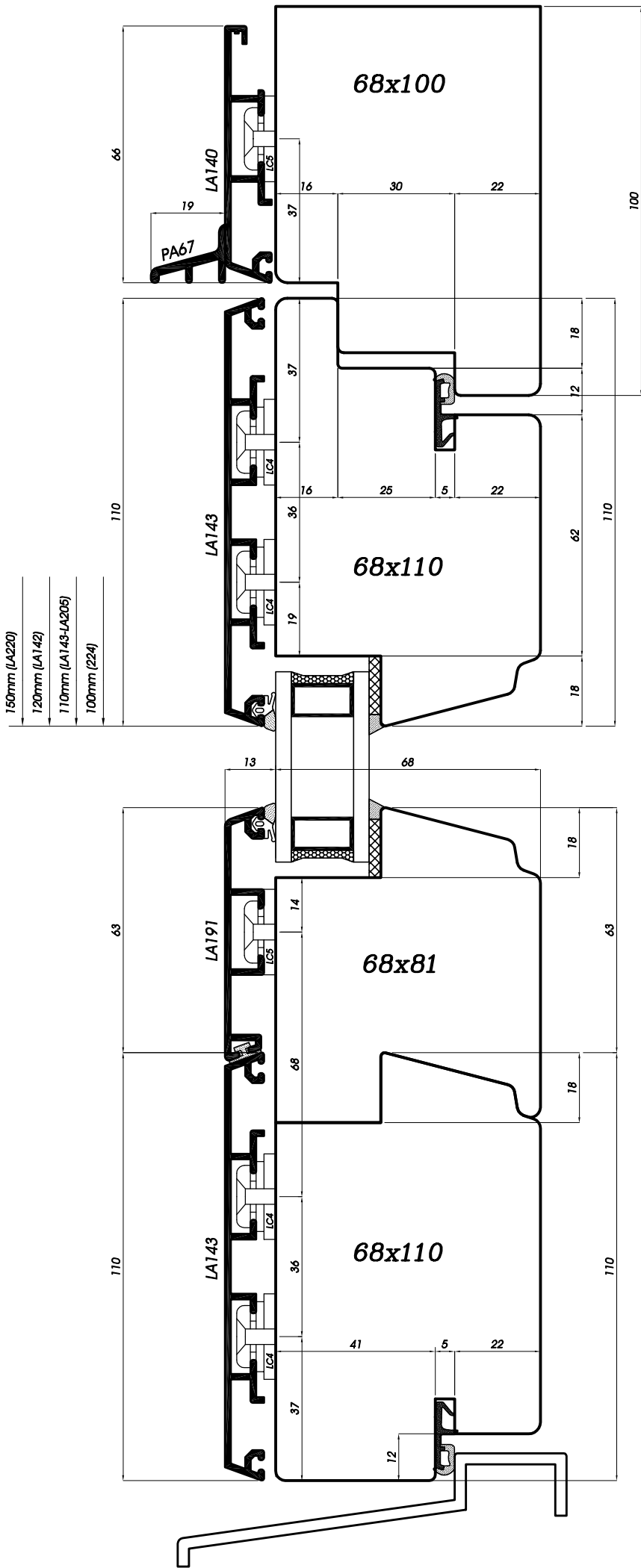

Sezione verticale serramento con apertura a sporgere  
 Vertikalschnitt Tür nach außen öffnend  
 Sección vertical de cerramiento con apertura hacia el exterior  
 Coupe verticale fenêtre avec ouverture vers l'extérieur  
 Vertical section of top-hinged window



Nuova cerniera regolabile nelle tre direzioni

- FS06/1F -Argento
  - FS06/5F -Bianco scuro
  - FS06/7F -Bianco RAL9016
  - FS06/9F -GREZZA
- Portata: Legno tenero kg.100  
Legno duro kg.120

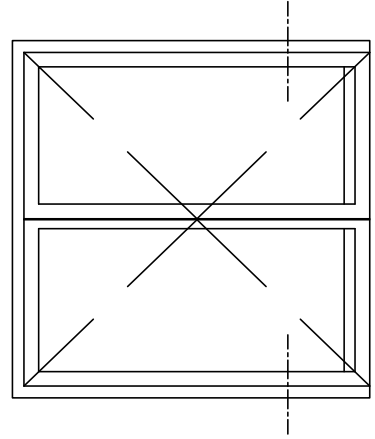
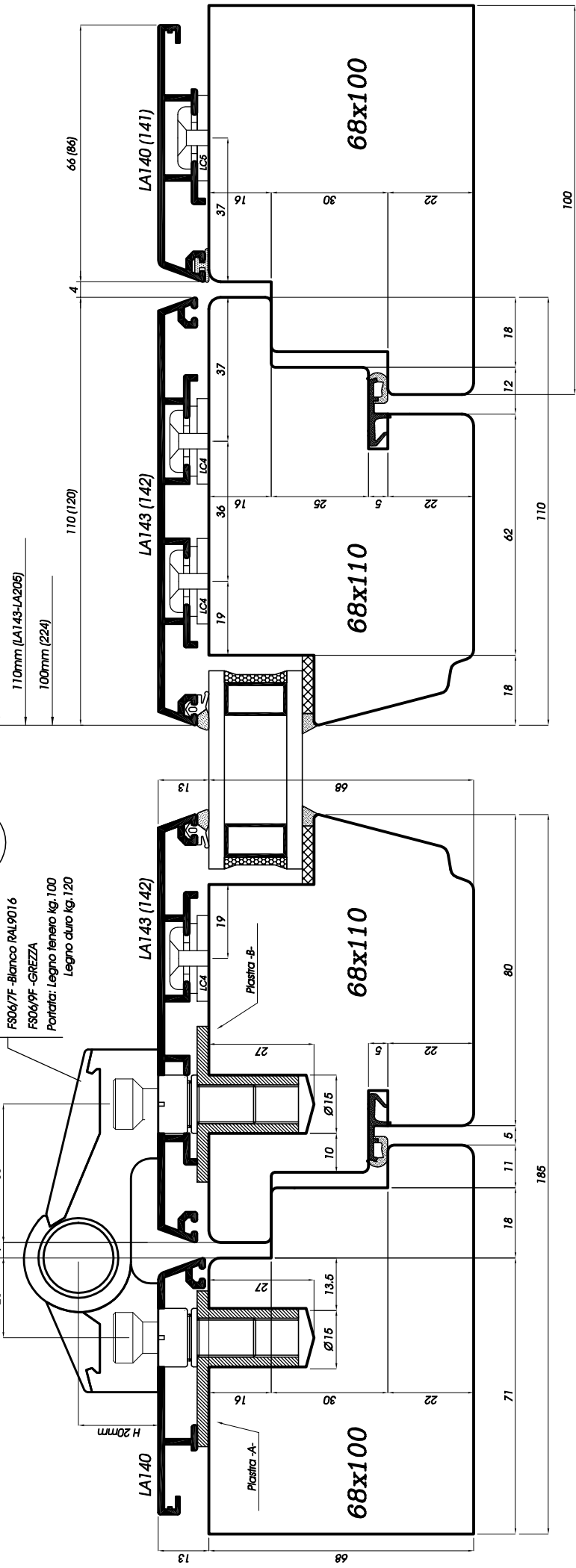

Sezione orizzontale serramento con apertura a sporgere  
 Horizontalschnitt Tür nach außen öffnend  
 Sección horizontal de cerramiento con apertura hacia el exterior  
 Coupe horizontale fenêtre avec ouverture vers l'extérieur  
 Horizontal section of top-hinged window

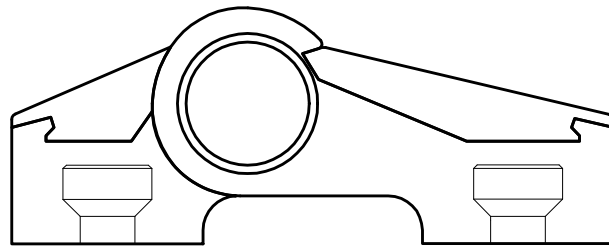

*Nuova cerniera regolabile nelle tre direzioni con chiave LD30*

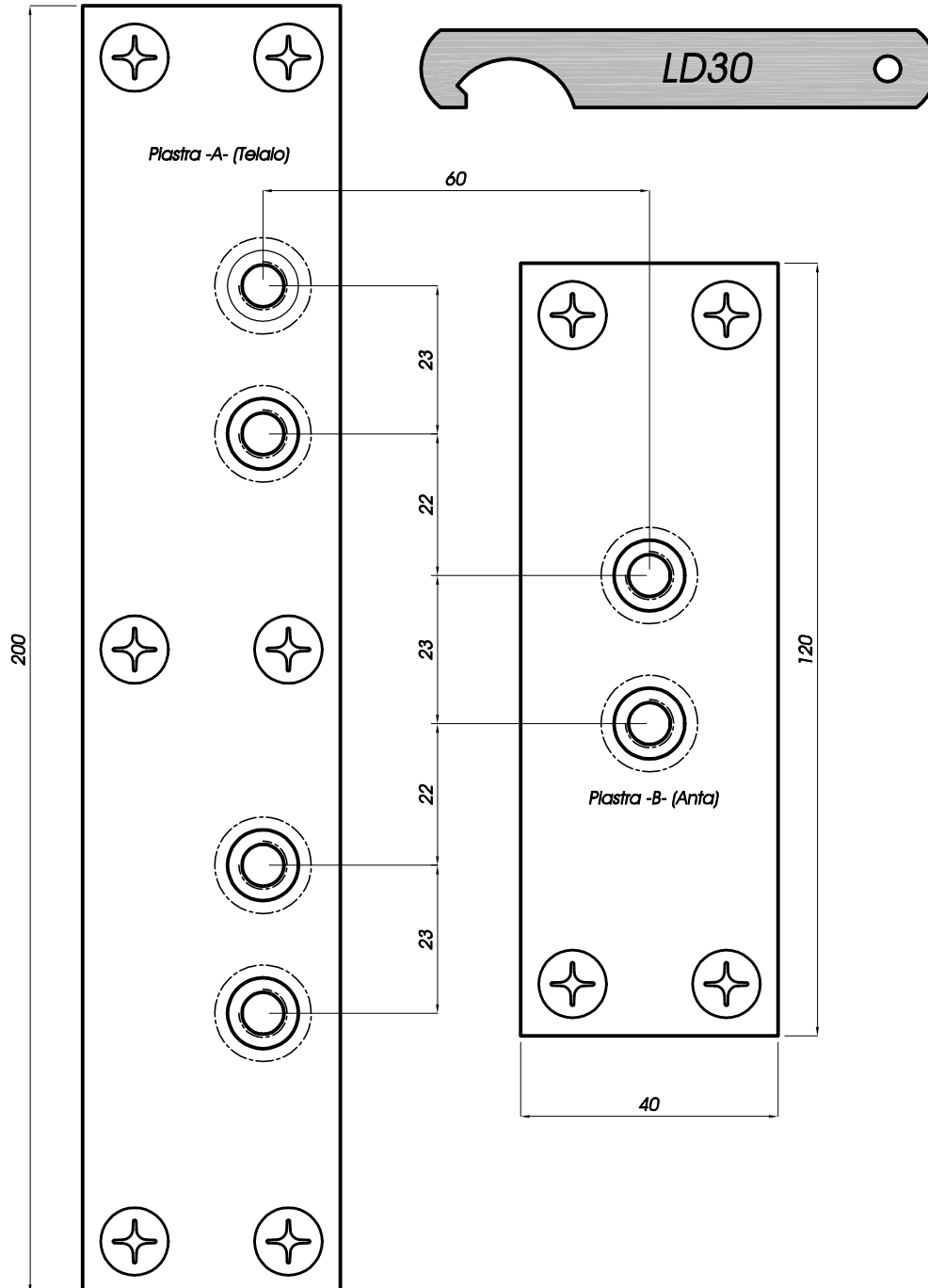

***Cerniera per apertura a sporgere***  
***Scharniere für nach Aussen aufgehende Öffnung***  
***Bisagra para apertura hacia el exterior.***  
***Charnière pour ouverture vers l'extérieur***  
***H hinge for the projected opening***

SISTEMI PER SERRAMENTI

**UNIFORM**

*Sistema Soft-Line*

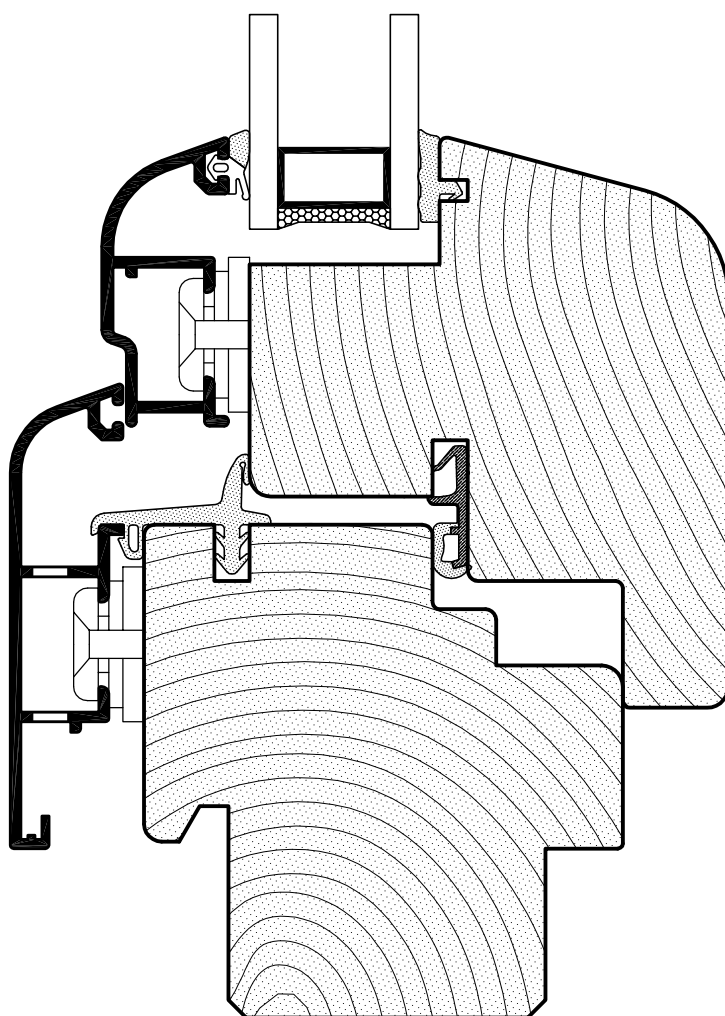



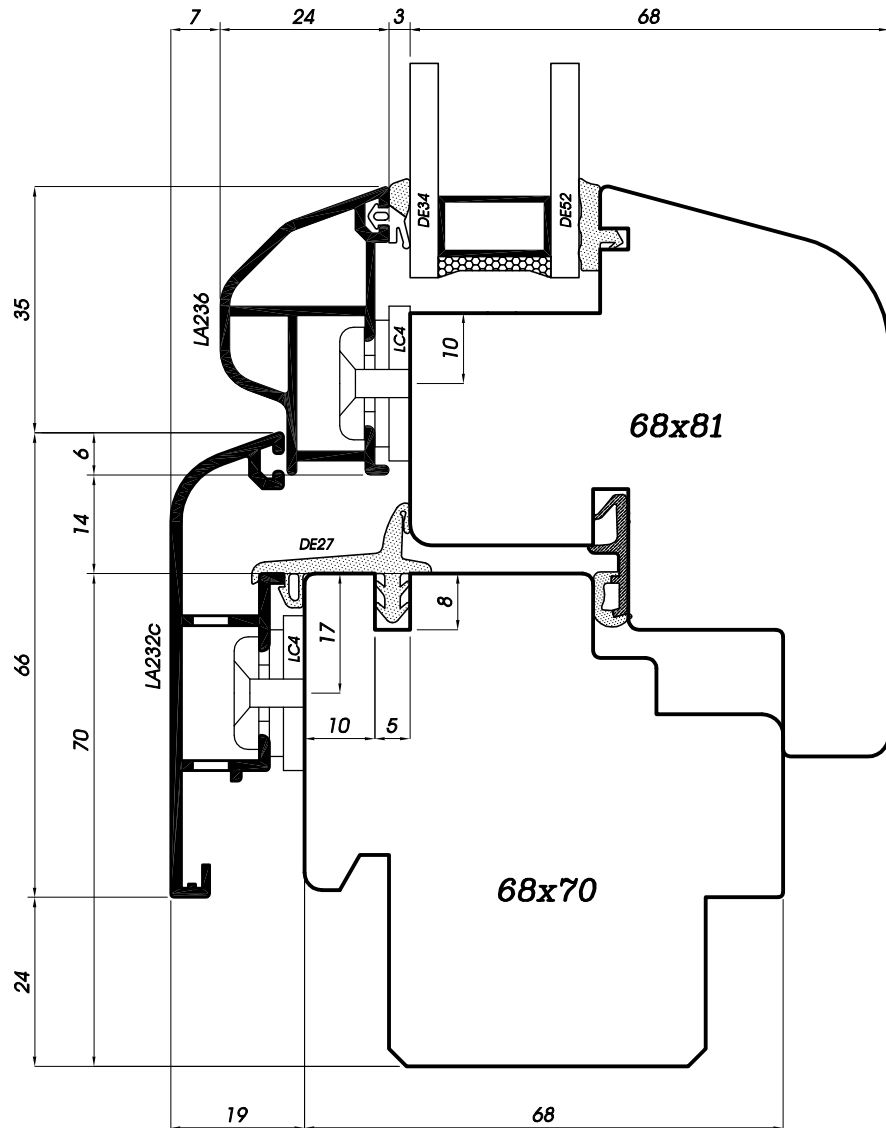
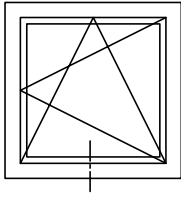

**Sezione verticale traverso inferiore finestra**  
**Vertikalschnitt Fenster quer unten**  
**Sección vertical travesaño inferior del marco**  
**Coupe verticale traverse inférieure fenêtre**  
**Vertical section of the window's lower ledge**

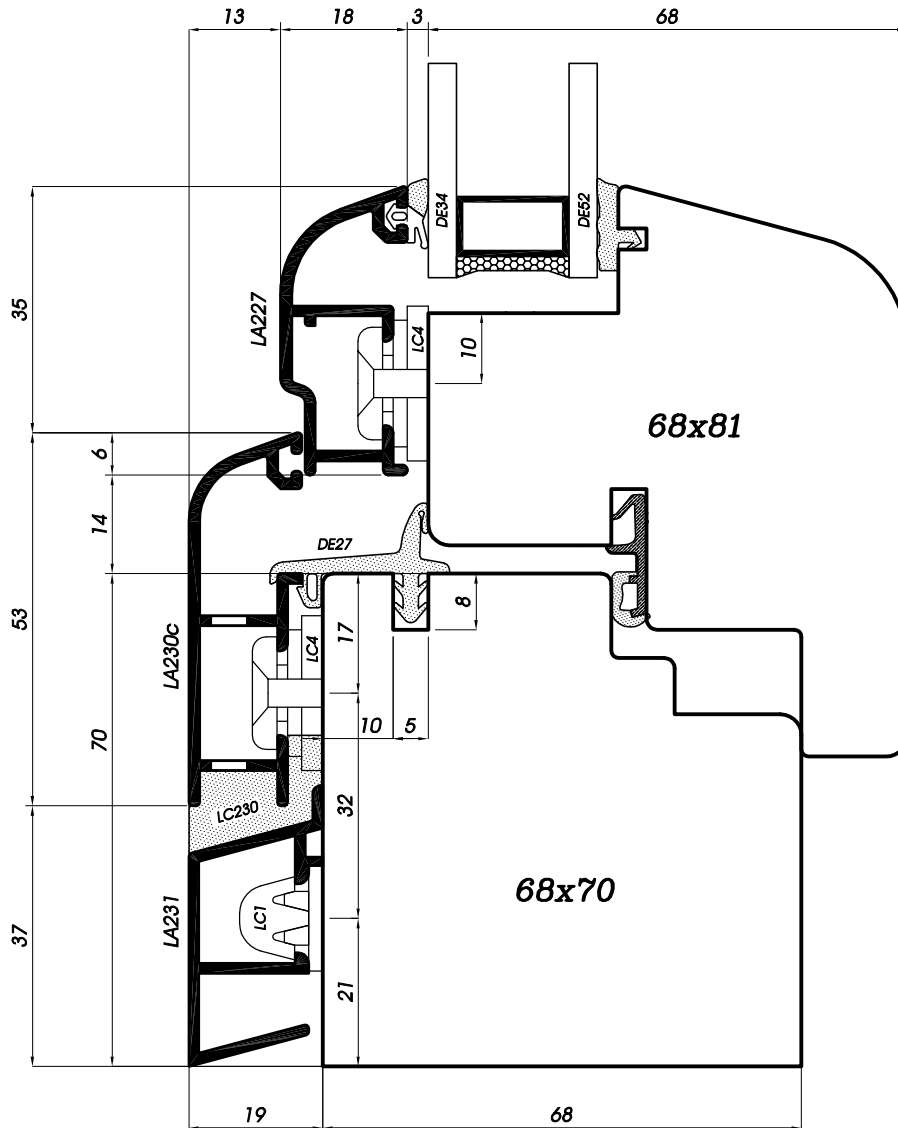
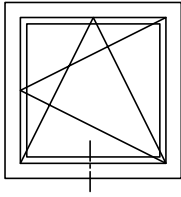

**Sezione verticale traverso inferiore finestra**  
**Vertikalschnitt Fenster quer unten**  
**Sección vertical travesaño inferior del marco**  
**Coupe verticale traverse inférieure fenêtre**  
**Vertical section of the window's lower ledge**

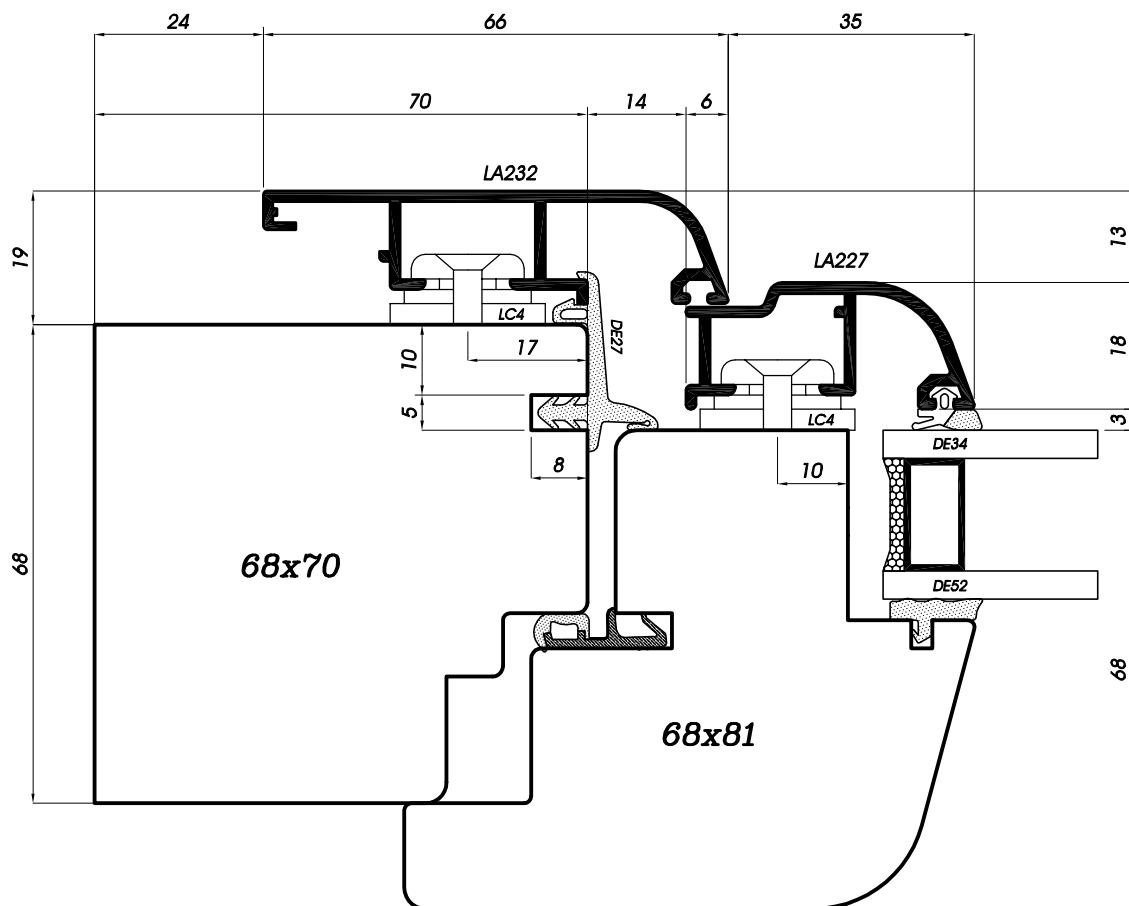
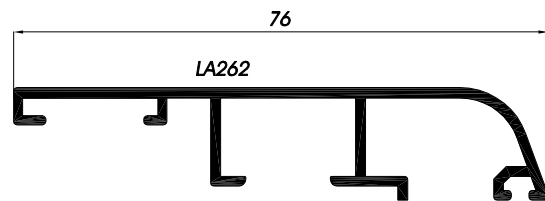
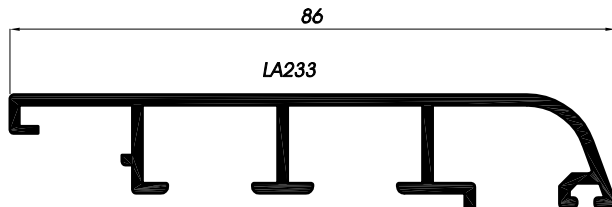
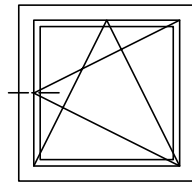
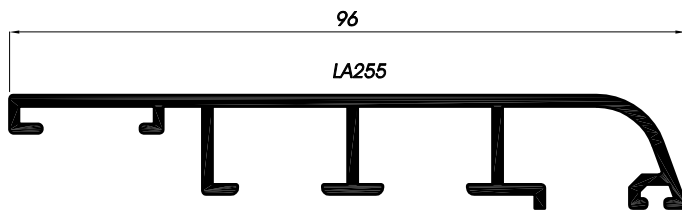

Sezione orizzontale montanti laterali  
 Horizontalschnitt senkrecht seitlich  
 Sección horizontal de montantes laterales  
 Coupe horizontale montants latéraux  
 Horizontal section of the lateral jambs

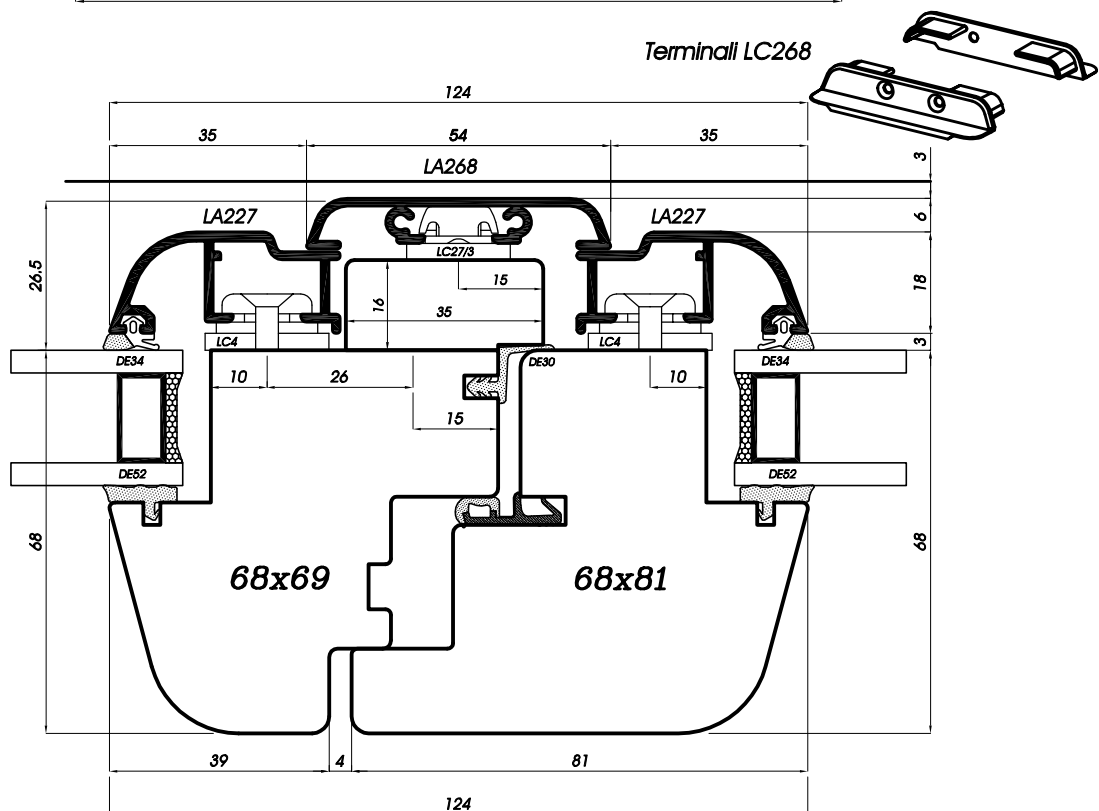
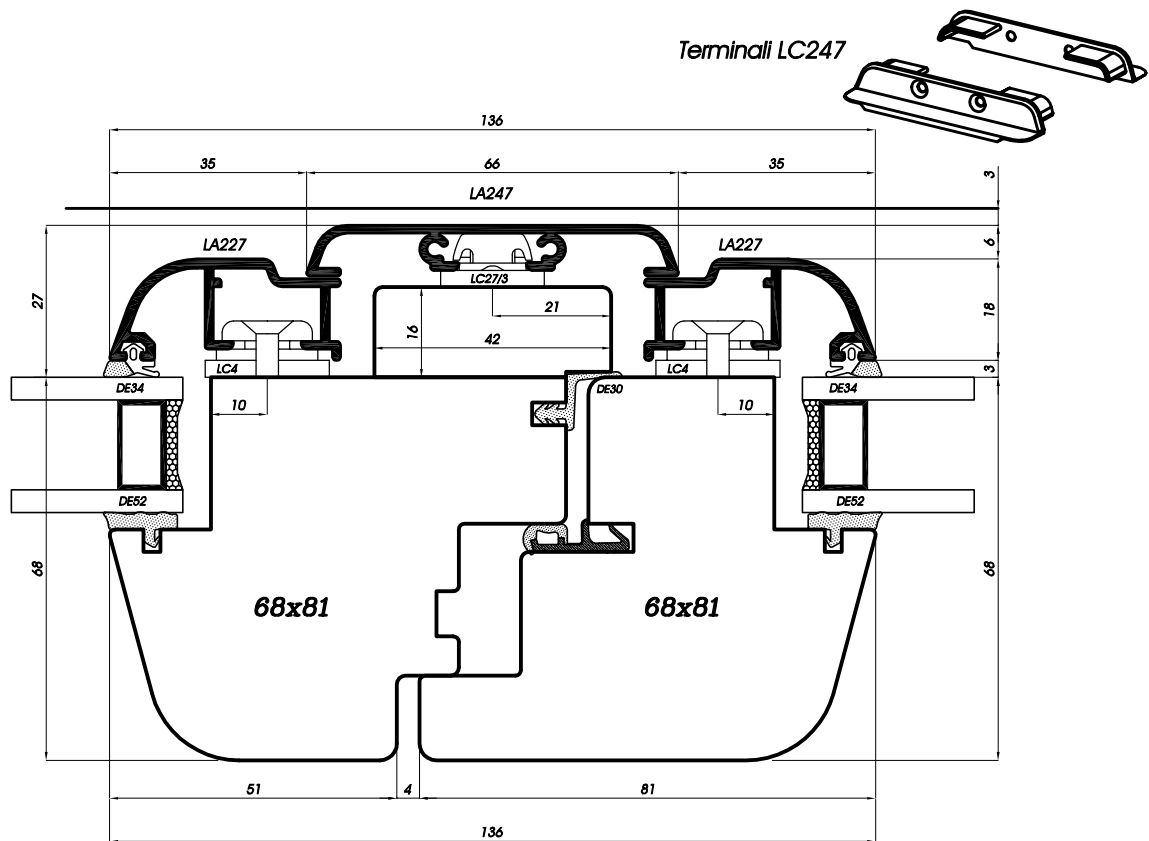

Sezione orizzontale chiusura centrale con profili LA247-LA268  
 Horizontalschnitt Stulpprofil LA247-LA268  
 Sección horizontal del cierre central con perfiles LA247-LA268  
 Coupe horizontale battement central avec profil LA247 - LA268  
 Horizontal section of the middle clamp with the profiles LA247-LA268

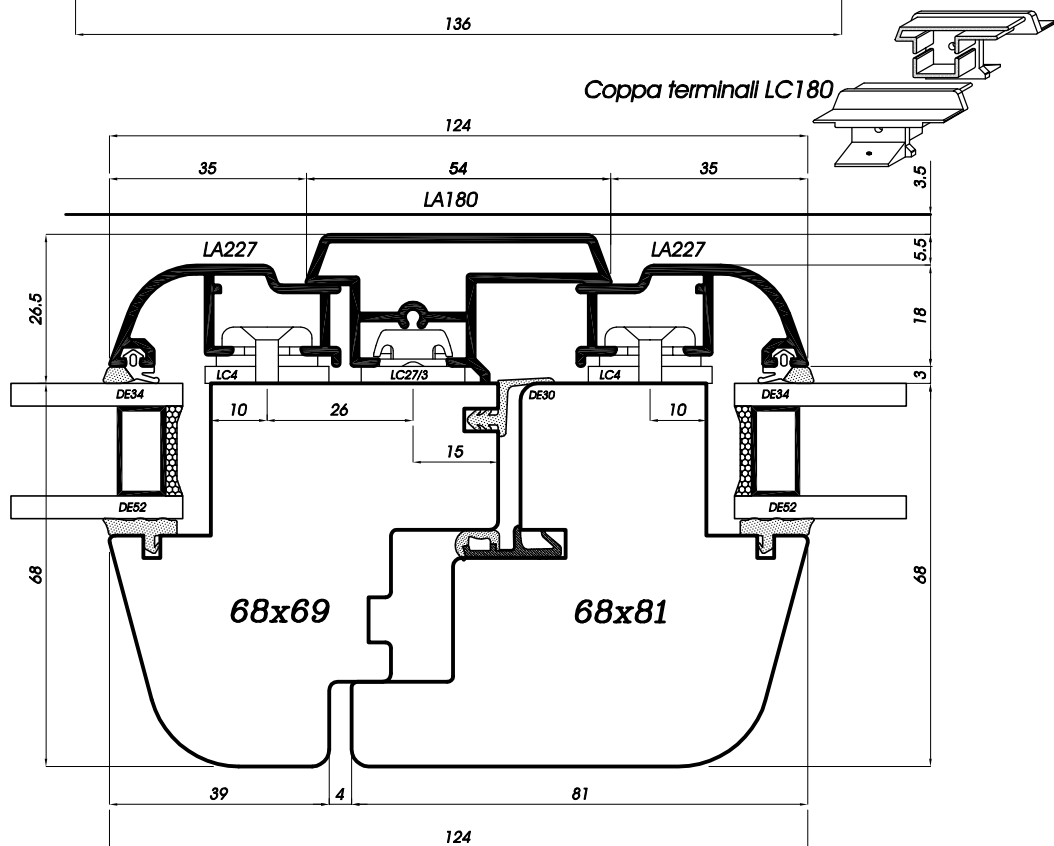
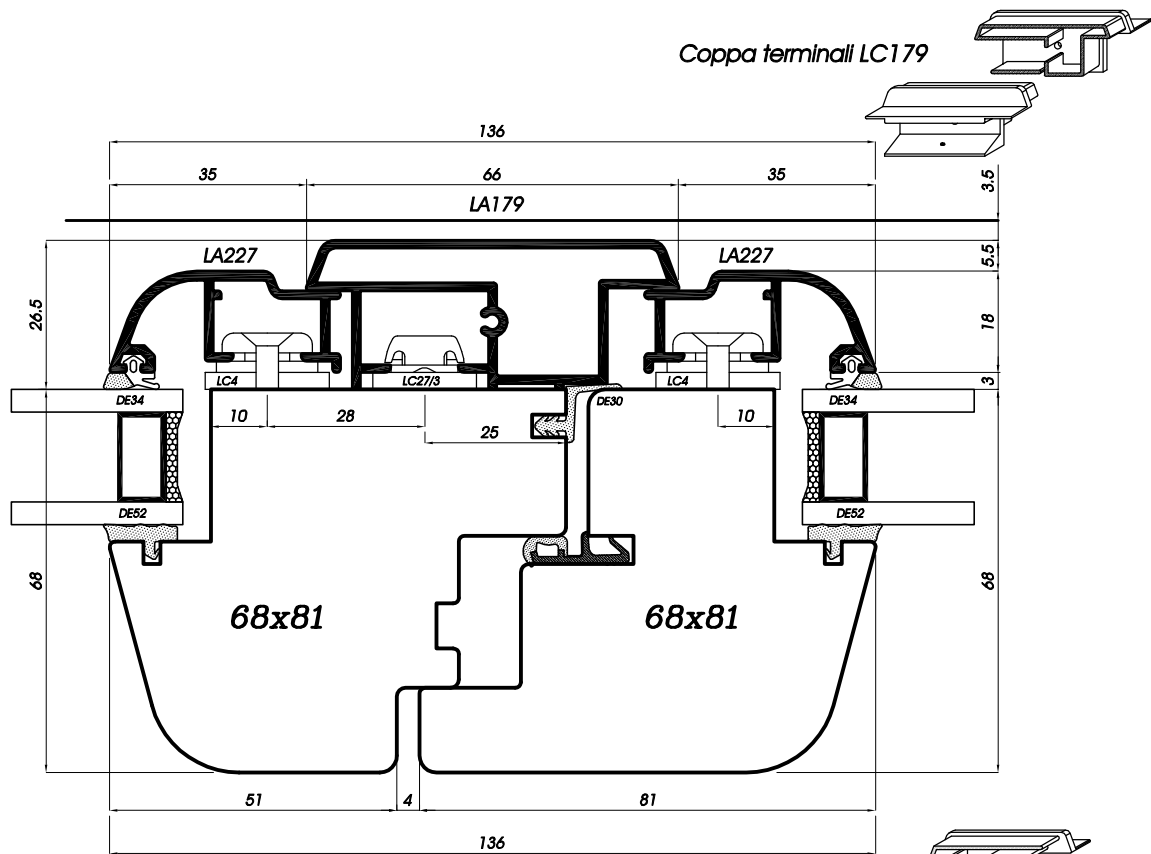

**Sezione orizzontale chiusura centrale con profili LA179-LA180**  
**Horizontalschnitt Stulpprofil LA179-LA180**  
**Sección horizontal del cierre central con perfiles LA179-LA180**  
**Coupe horizontale battement central avec profil LA179 - LA180**  
**Horizontal section of the middle clamp with the profiles LA179-LA180**

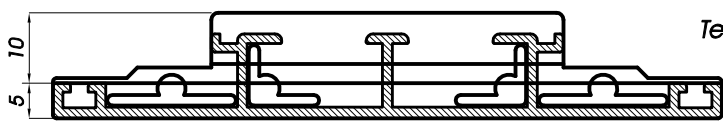
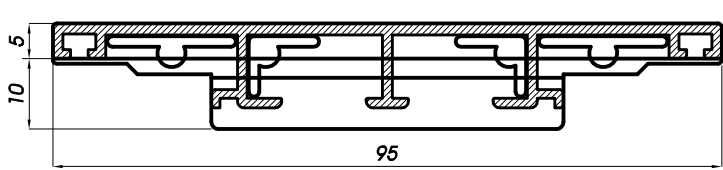
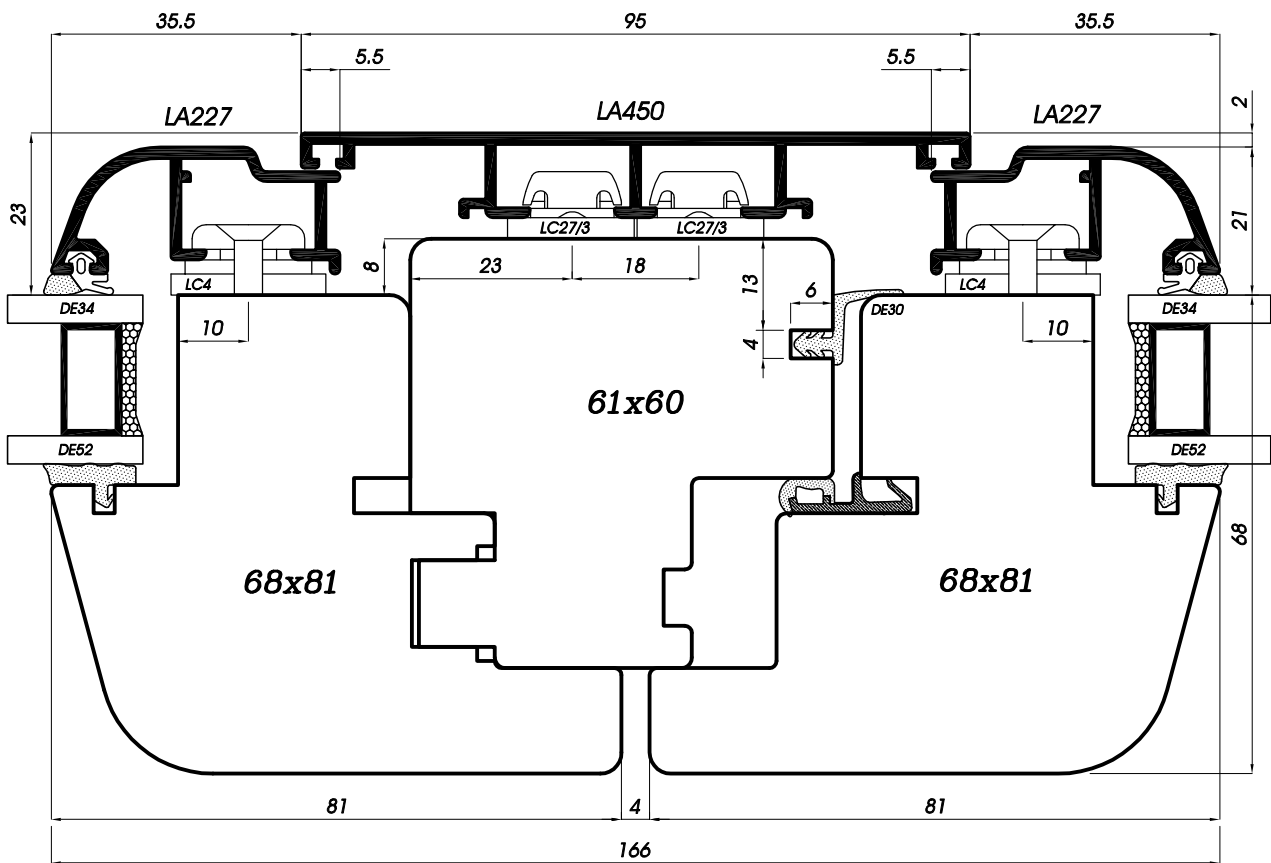

Incollare terminale con LCTENAX

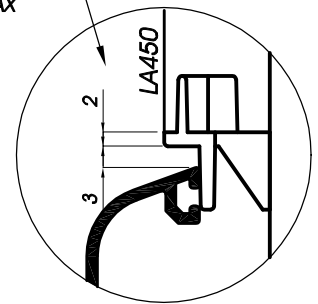

Terminali LC450

Sezione orizzontale chiusura centrale con profilo LA450  
 Horizontalschnitt Stulpprofil LA450  
 Sección horizontal del cierre central con perfil LA450  
 Coupe horizontale battement central avec profil LA450  
 Horizontal section of the middle clamp with the profile LA450

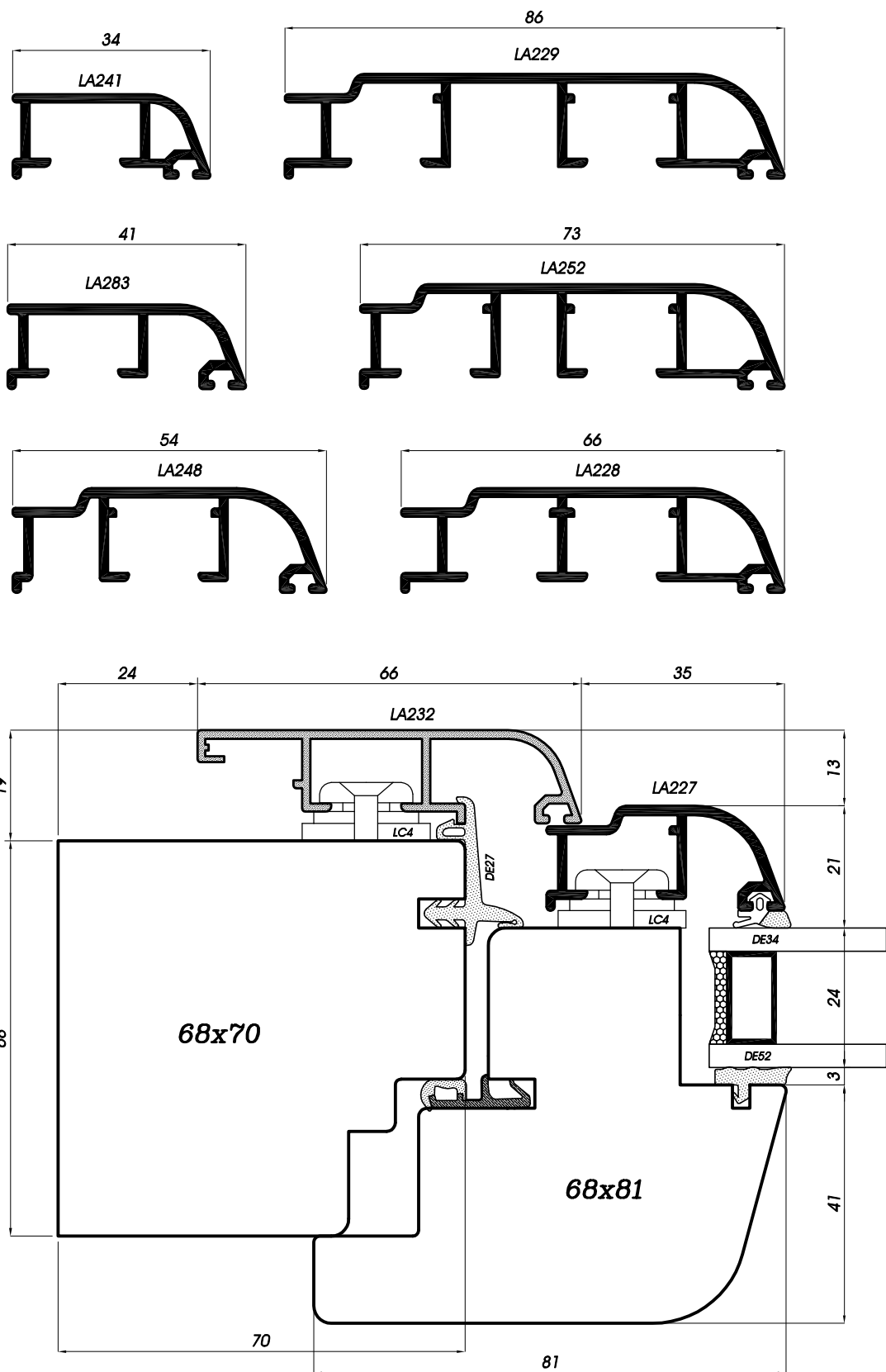

Sezioni orizzontali battenti  
 Horizontalschnitte Flügel  
 Secciones horizontales hojas  
 Coupes horizontales vantaux  
 Horizontal section of the wings

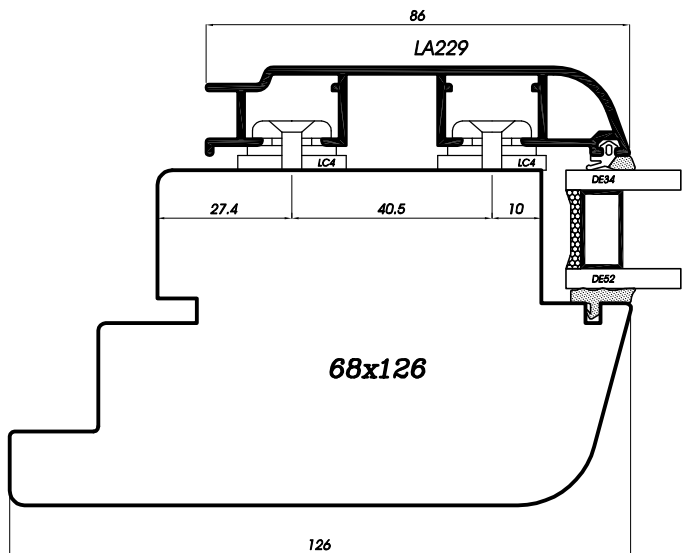
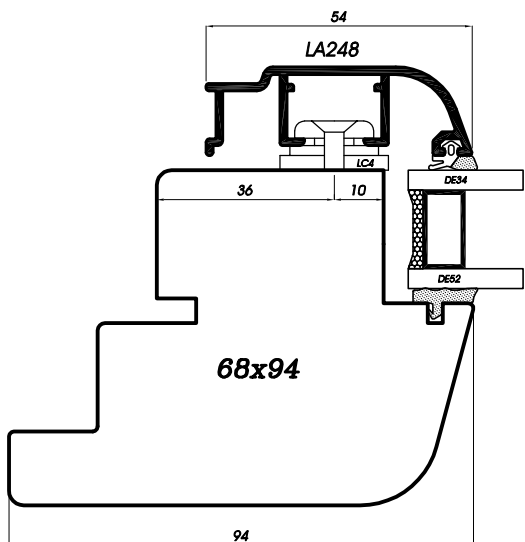
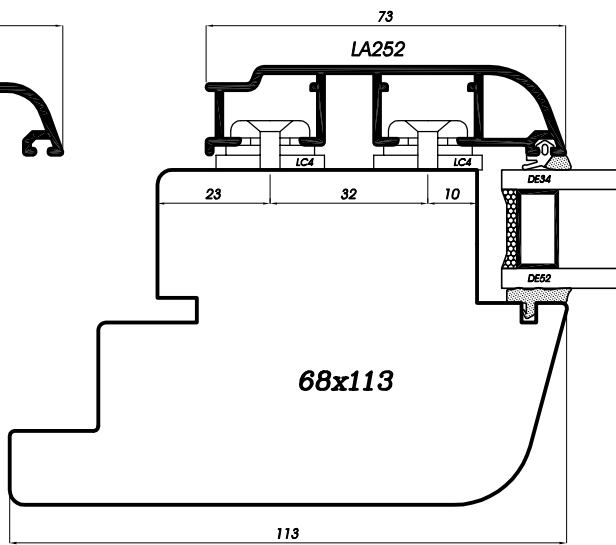
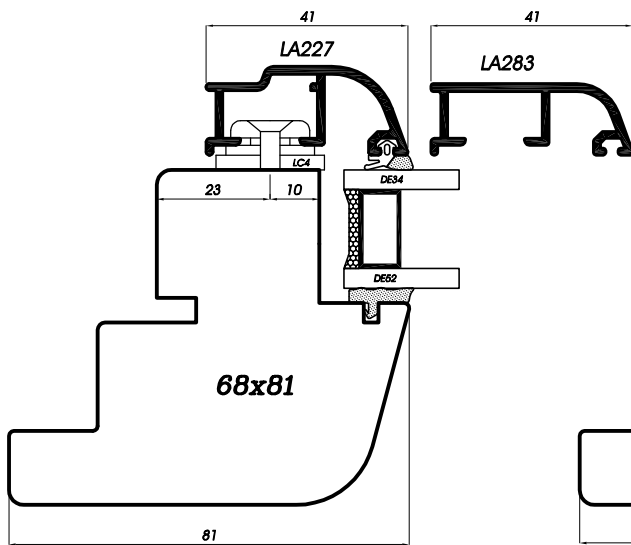
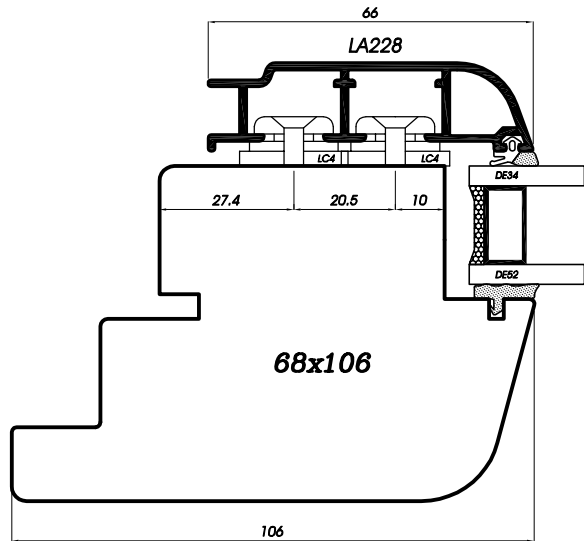
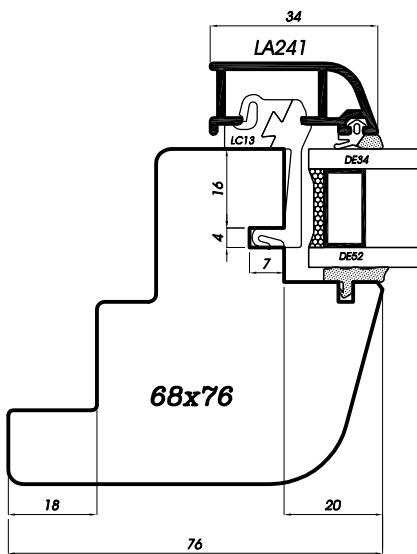

**Sezioni orizzontali battenti**  
**Horizontalschnitte Flügel**  
**Secciones horizontales hojas**  
**Coupes horizontales vantaux**  
**Horizontal section of the wings**



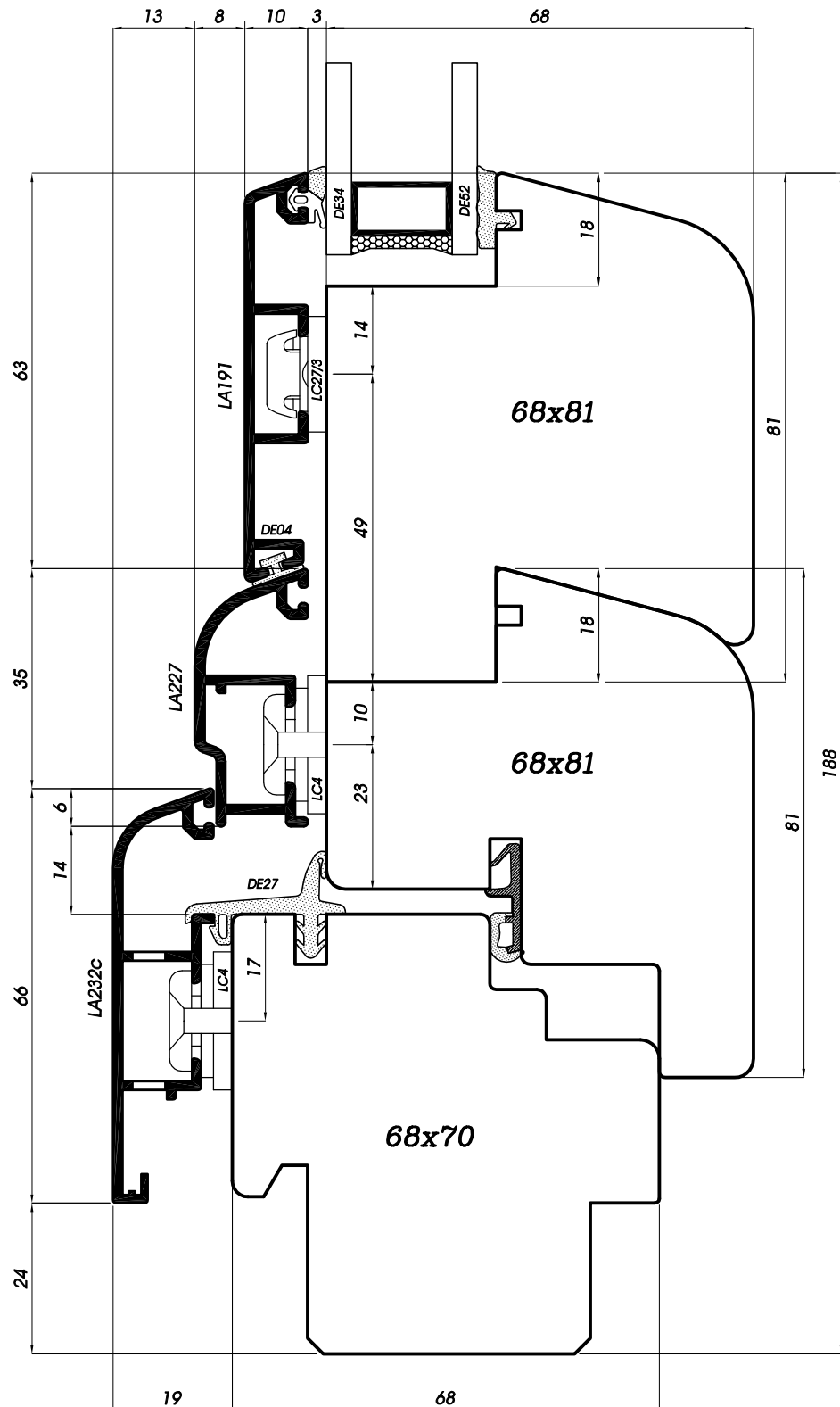
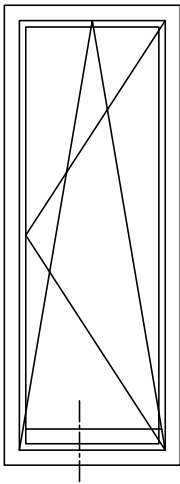

**Sezione verticale traverso inferiore portafinestra**  
**Vertikalschnitt Balkontür quer unten**  
**Sección vertical travesaño inferior puertaventana**  
**Coupe verticale traverse inférieure porte-fenêtre**  
**Vertical section of the lower ledger for window-door**

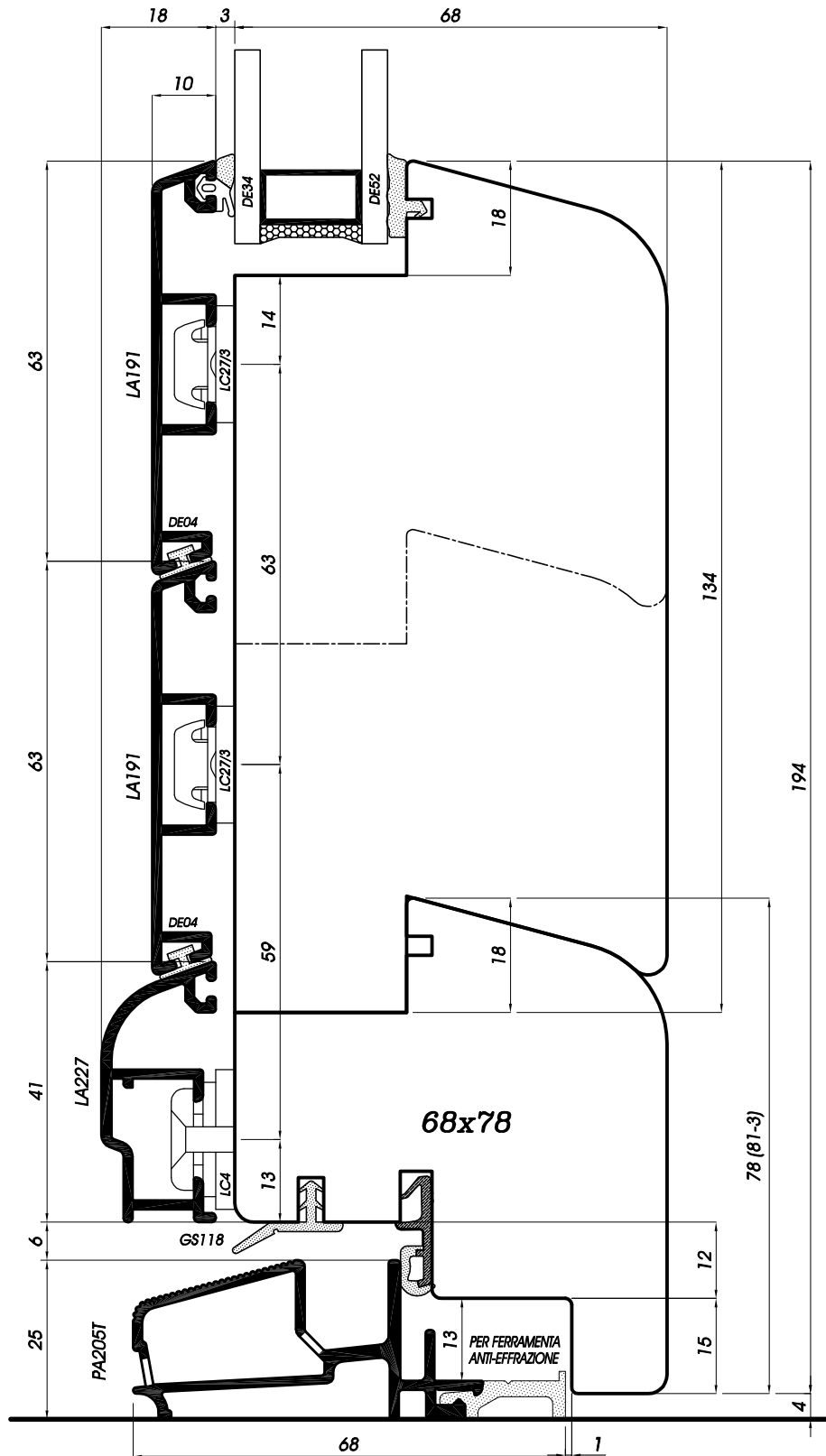
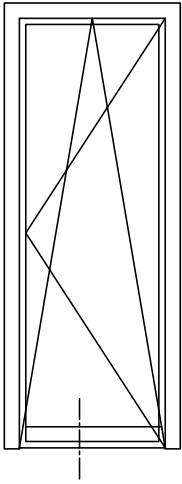

Sezione verticale traverso inferiore portafinestra con PA205T  
 Vertikalschnitt Balkontür quer unten mit PA205T  
 Sección vertical travesaño inferior puertaventana con PA205T  
 Coupe verticale traverse inférieure porte-fenêtre avec PA205T  
 Vertical section of the lower ledger for window-door with PA205T

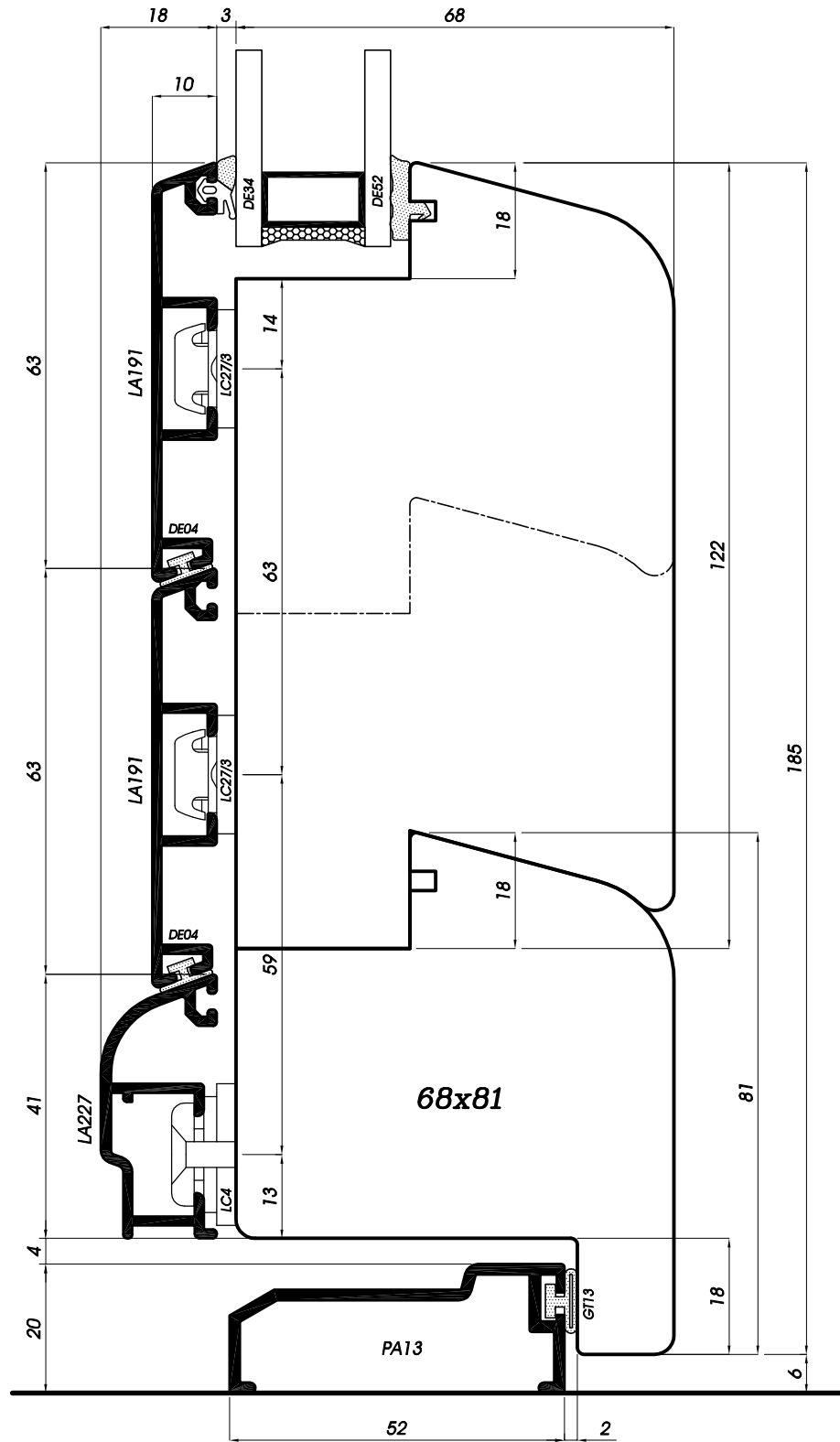
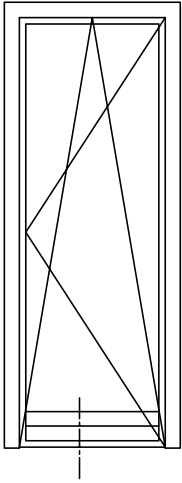

**Sezione verticale traverso inferiore portafinestra con PA13**  
**Vertikalschnitt Balkontür quer unten mit PA13**  
**Sección vertical travesaño inferior puertaventana con PA13**  
**Coupe verticale traverse inférieure porte-fenêtre avec PA13**  
**Vertical section of the lower ledger for window-door with PA13**

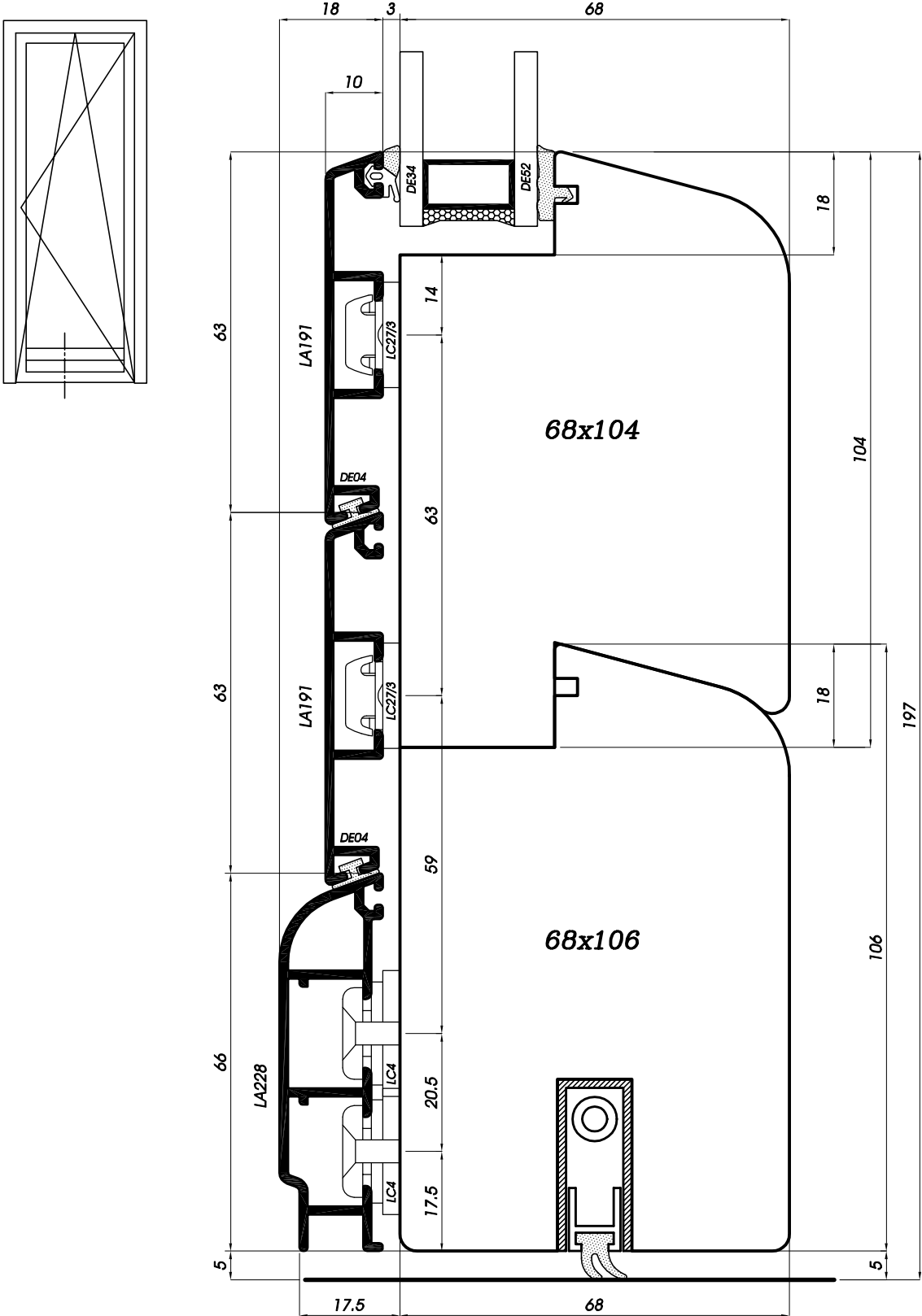

**Sezione verticale traverso inferiore portafinestra con parafreddo**  
**Vertikalschnitt Balkontür quer unten mit Kälteschutz**  
**Sección vertical travesaño inferior puertaventana con parafrió**  
**Coupe verticale traverse inférieure porte-fenêtre avec clonette**  
**Vertical section of the lower ledger for window-door with cold-defender**

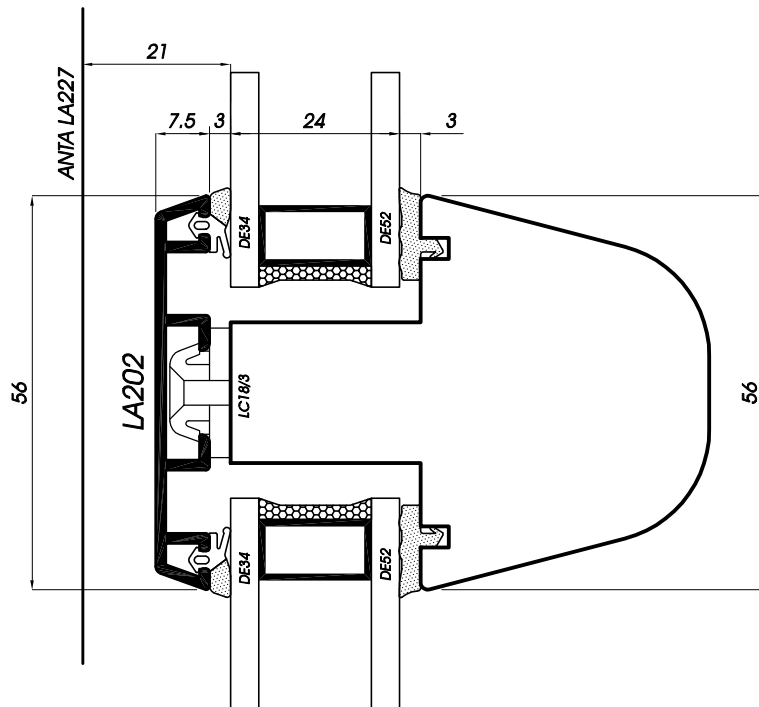
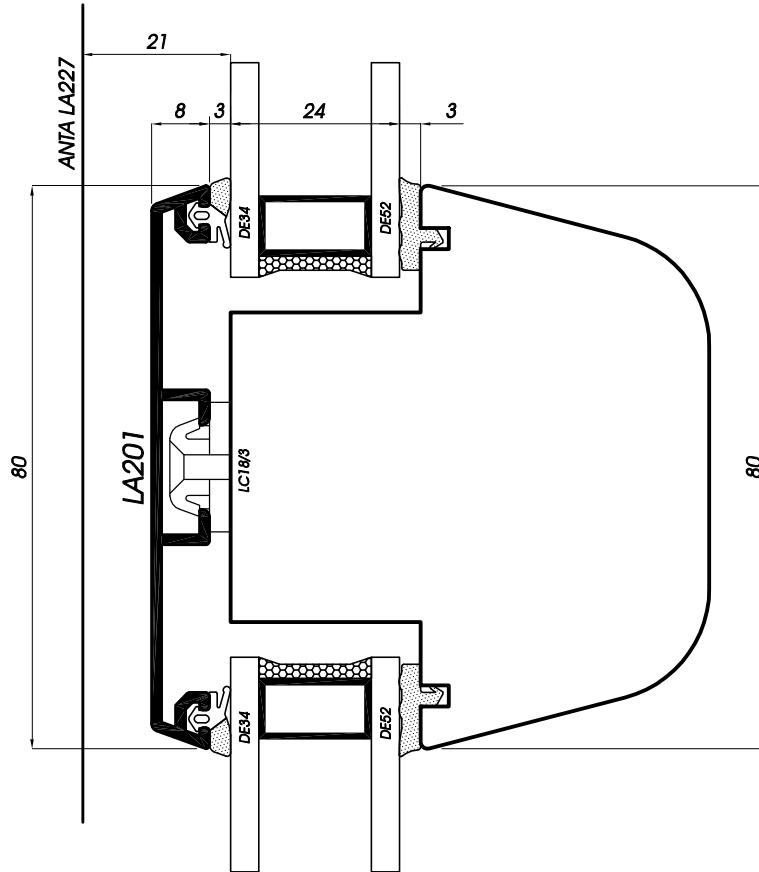

**Sezione verticale traversi intermedi anta**  
**Vertikalschnitt Flügelsprossen**  
**Sección vertical travesaños intermedios hojas**  
**Coupe verticale traverses intermédiaires vantail**  
**Vertical section of the wing's middle ledgers**

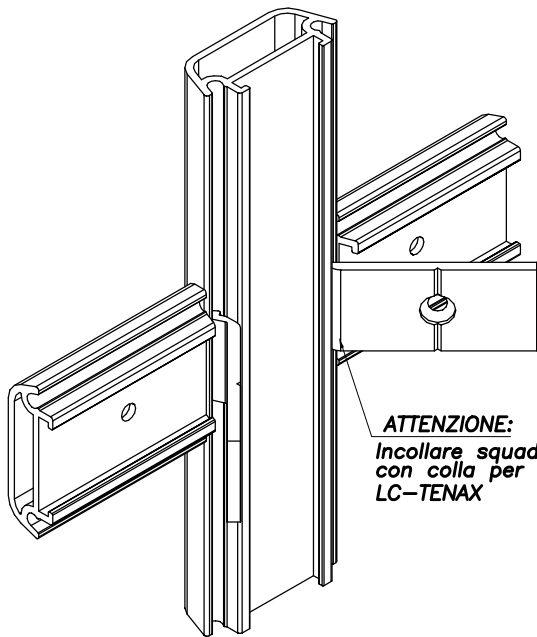

**ATTENZIONE:**  
 Incollare squadrette  
 con colla per metalli  
 LC-TENAX

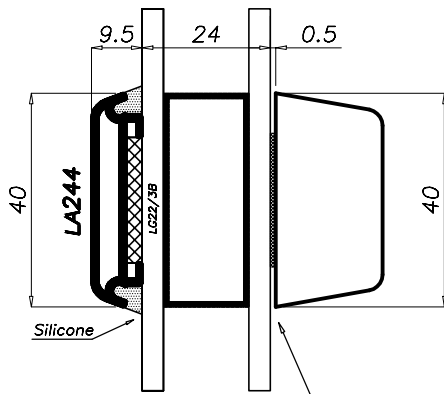
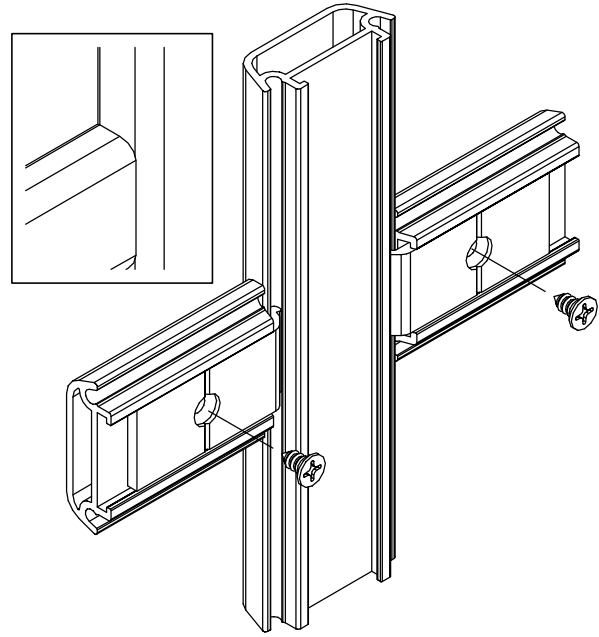

NASTRO BIADESIVO LCN19

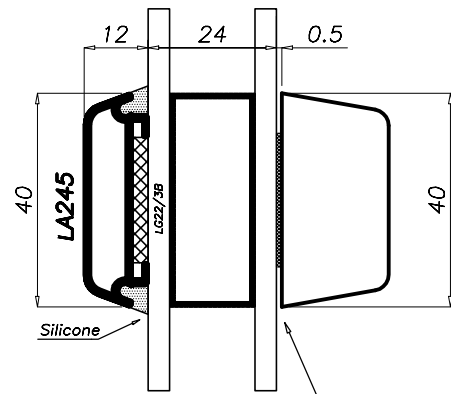

NASTRO BIADESIVO LCN19

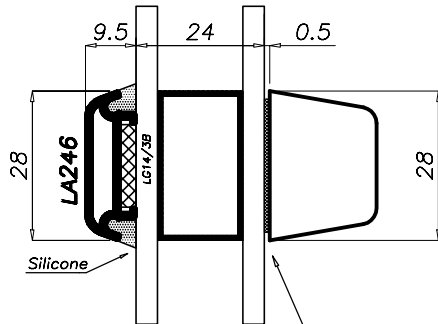

NASTRO BIADESIVO LCN19

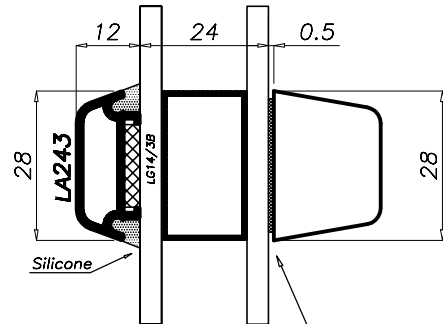

NASTRO BIADESIVO LCN19

**Assemblaggio a croce traversi anta**  
**Kreuzverbindung der Flügelssprossen**  
**Ensamblaje cruzado travesaños de la hoja**  
**Système d'assemblage pour croisillon**  
**Cross-Assembling of the wing's ledgers**

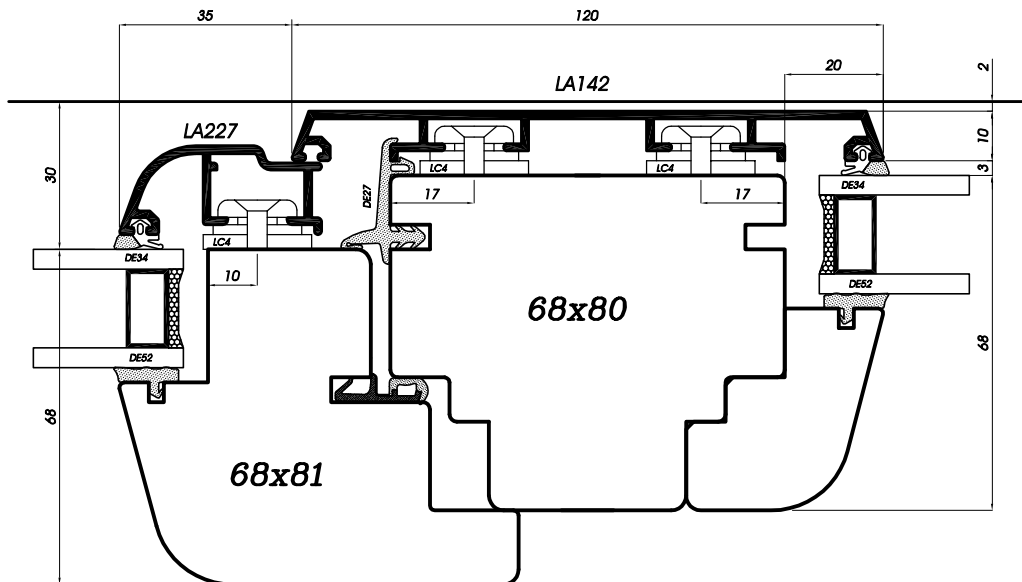
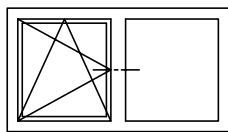
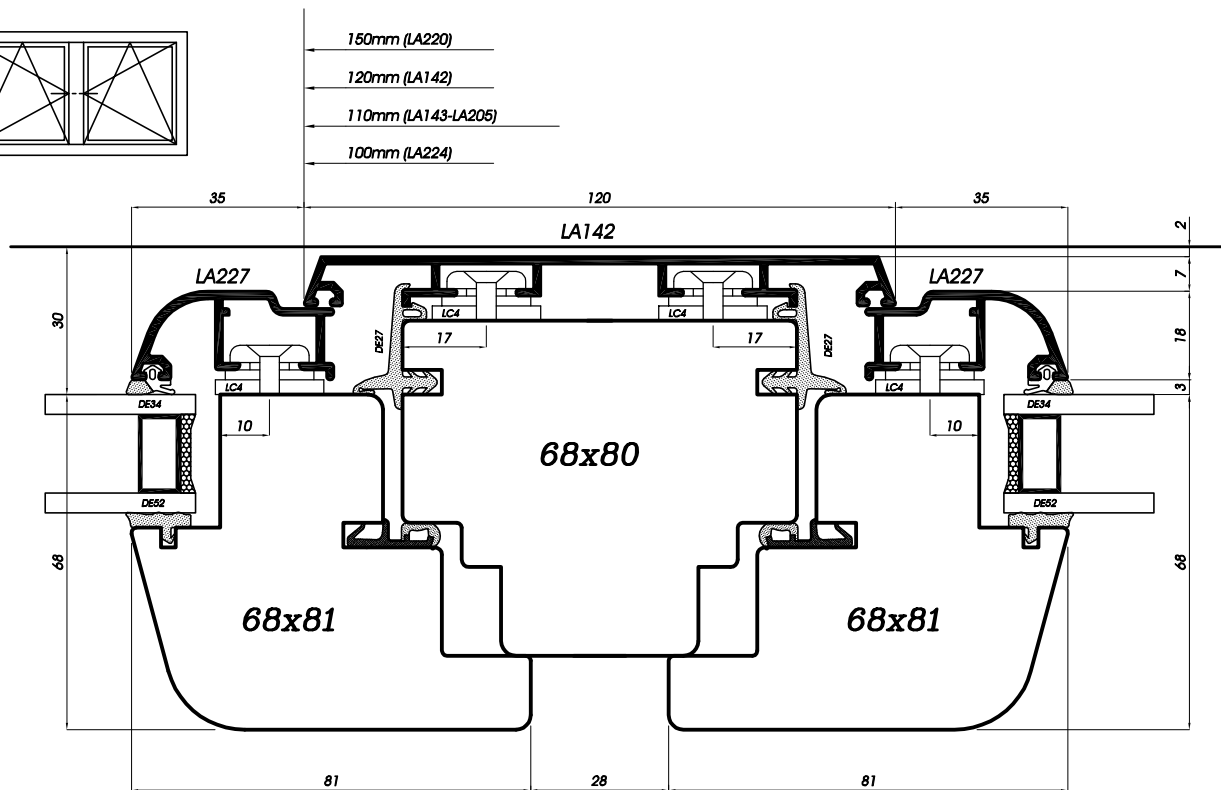
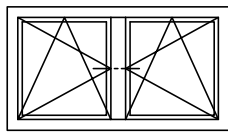

**Sezione orizzontale montanti intermedi telaio**  
**Horizontalschnitt Setzholz Rahmen**  
**Sección horizontal montantes intermedios del marco**  
**Coupe horizontale montants intermédiaires dormant**  
**Horizontal section of the frame's middle ledgers**

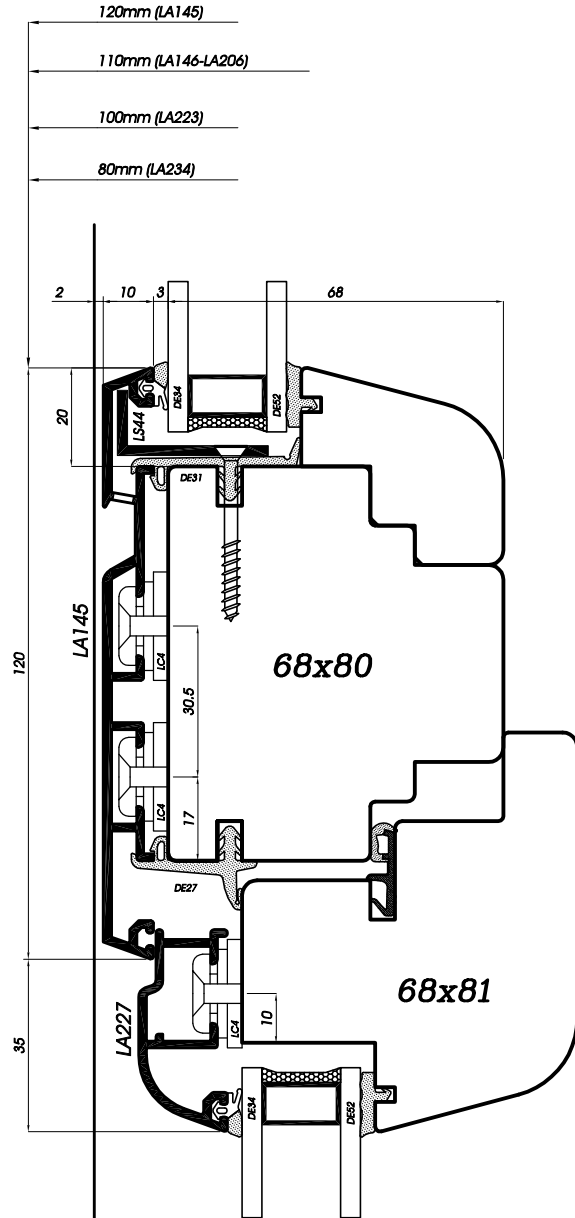
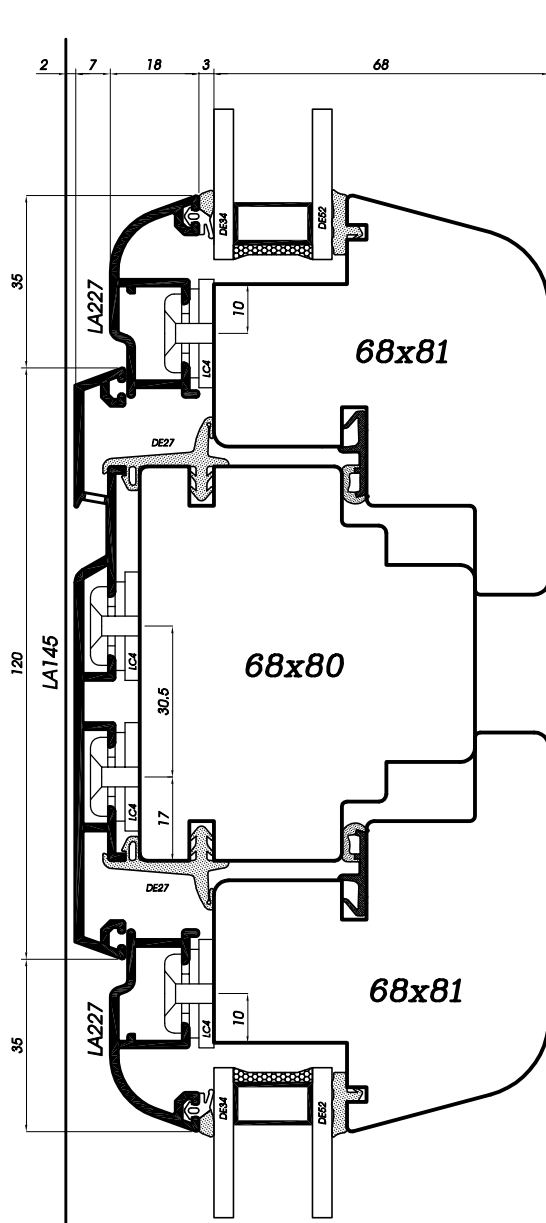
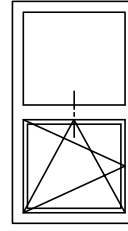
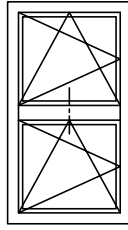

Sezione verticale traversi intermedi telaio  
 Vertikalschnitt Rahmensprossen  
 Sección vertical travesaños intermedios del marco  
 Coupe verticale des traverses intermédiaires du dormant  
 Vertical section of the frame's middle ledger



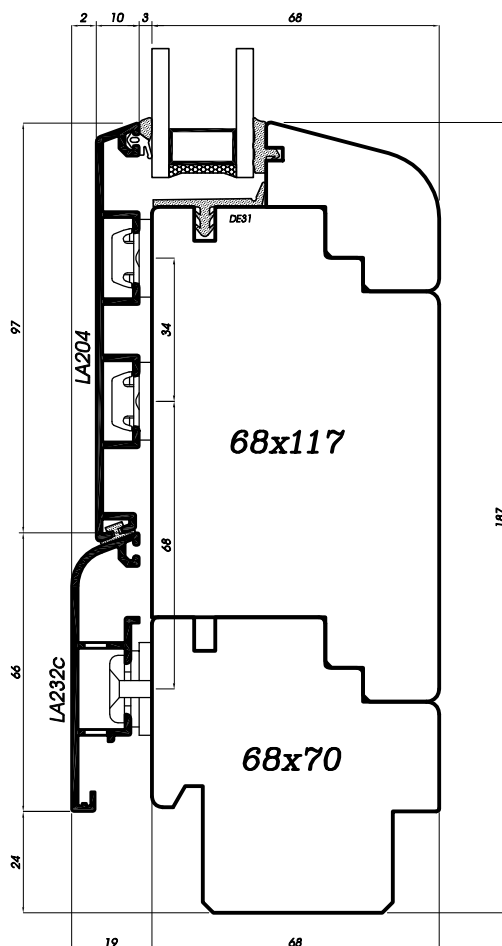
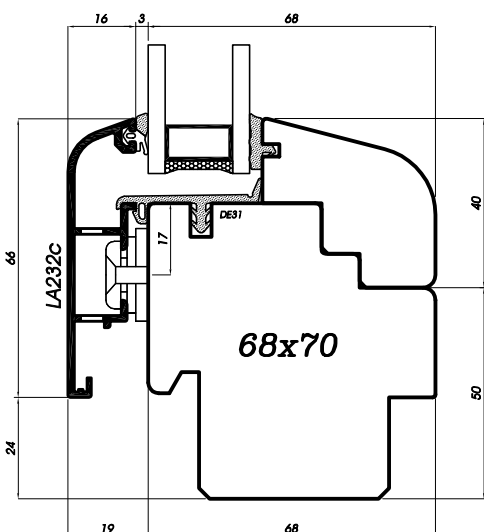
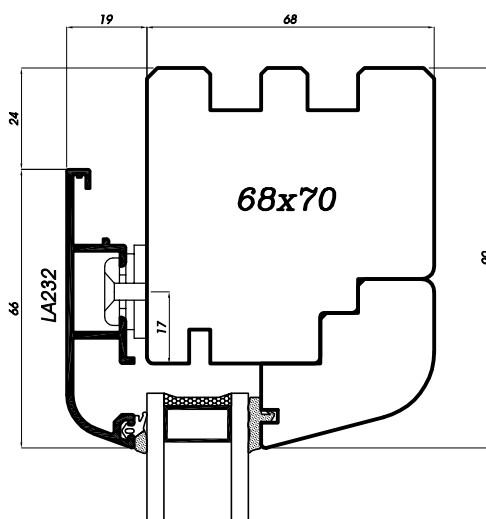
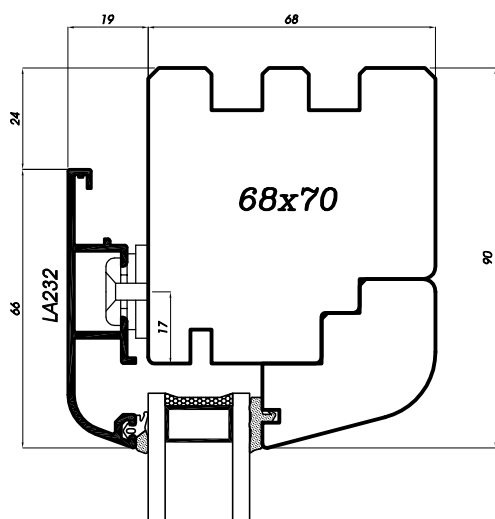

Sezione verticale finestra e portafinestra con vetro fisso  
 Vertikalschnitt Fenster und Balkontür mit Fixverglasung  
 Sección vertical ventana y puertaventana con cristal fijo  
 Coupe verticale fenêtre et porte-fenêtre avec vitre fixe  
 Vertical section of the window and the window-door with fixed glass

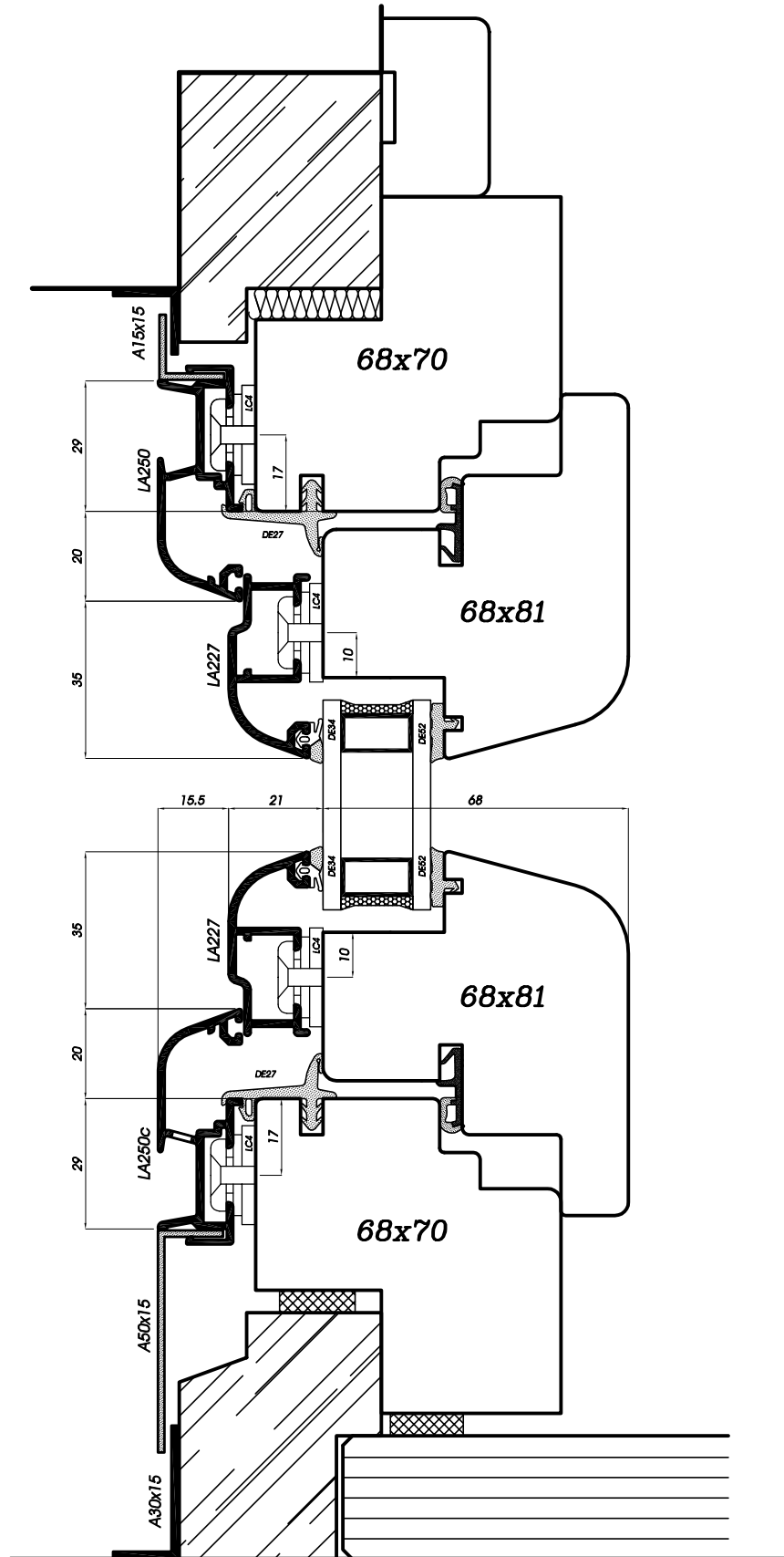
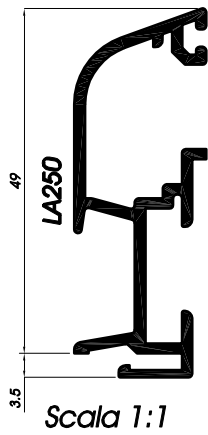
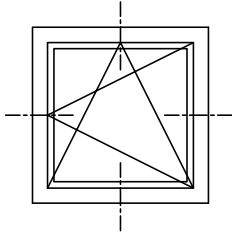

Sezione verticale con profilo LA250c per la ristrutturazione  
 Vertikalschnitt mit Profil LA250c für Sanierung  
 Sección vertical con perfil LA250c para la rehabilitación  
 Coupe verticale avec profil LA250c pour la rénovation  
 Vertical section with profil LA250C for the redevelopment

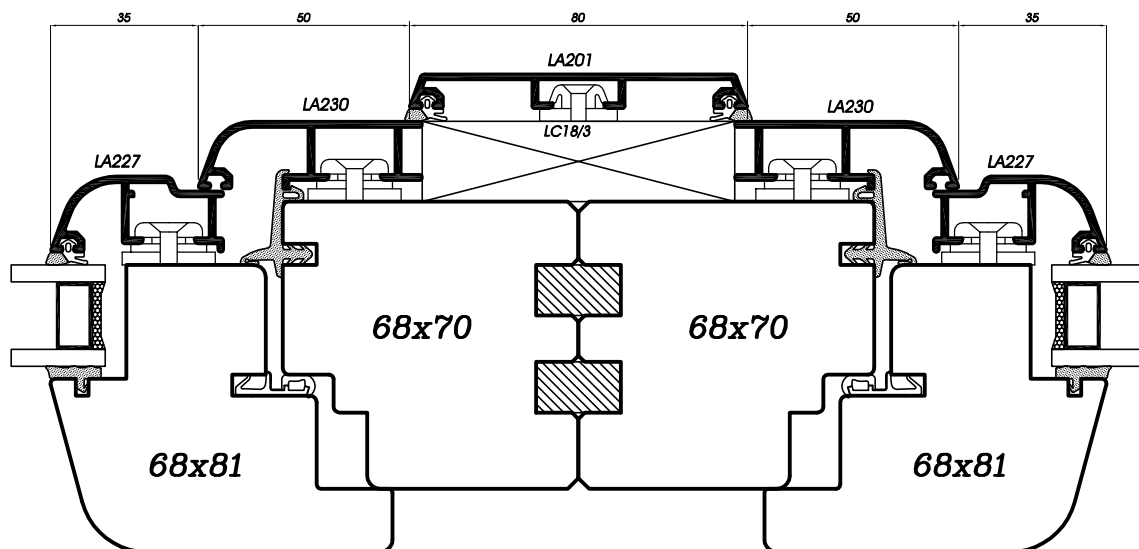
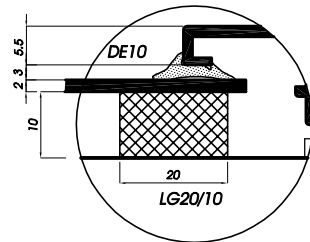
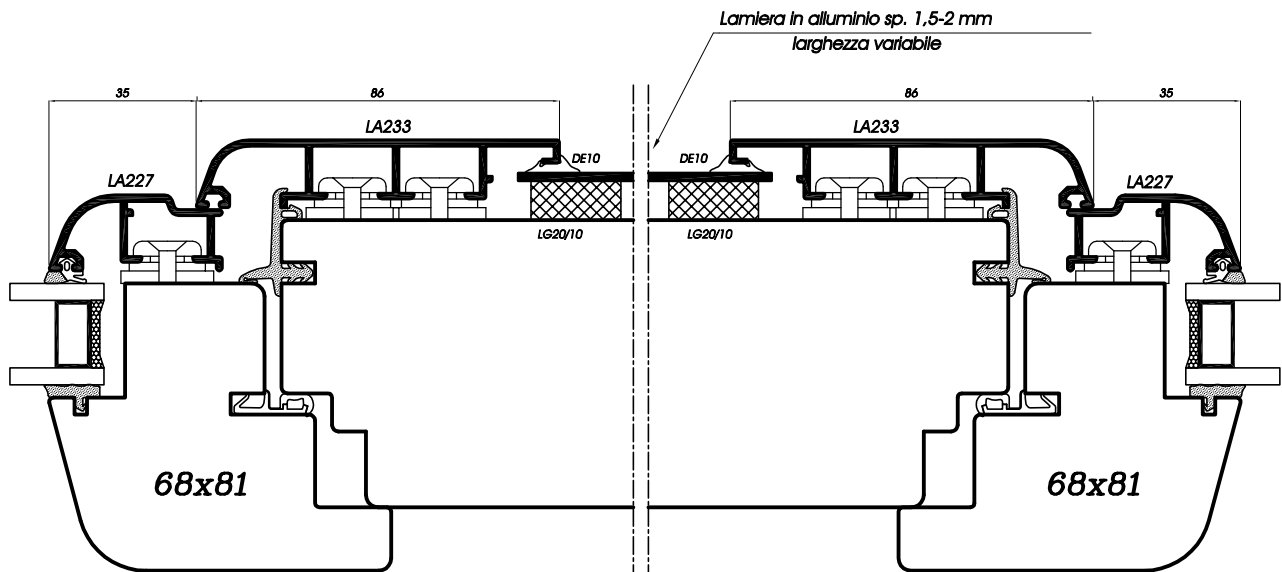

Sezione orizzontale finestre accoppiate  
 Horizontalschnitt gekoppelte Fenster  
 Sección horizontal de ventanas acopladas  
 Coupe horizontale accouplement de dormants  
 Horizontal section of the connected windows

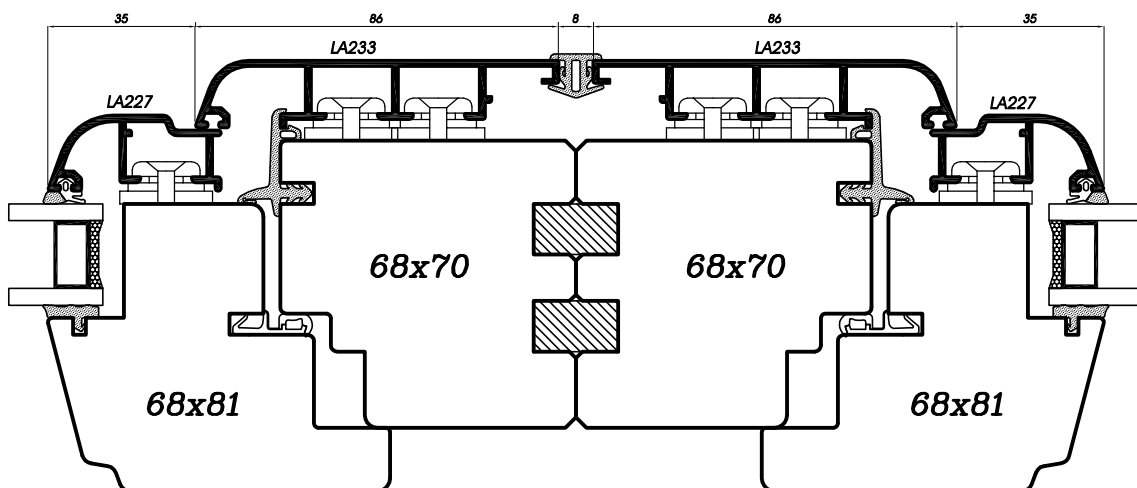
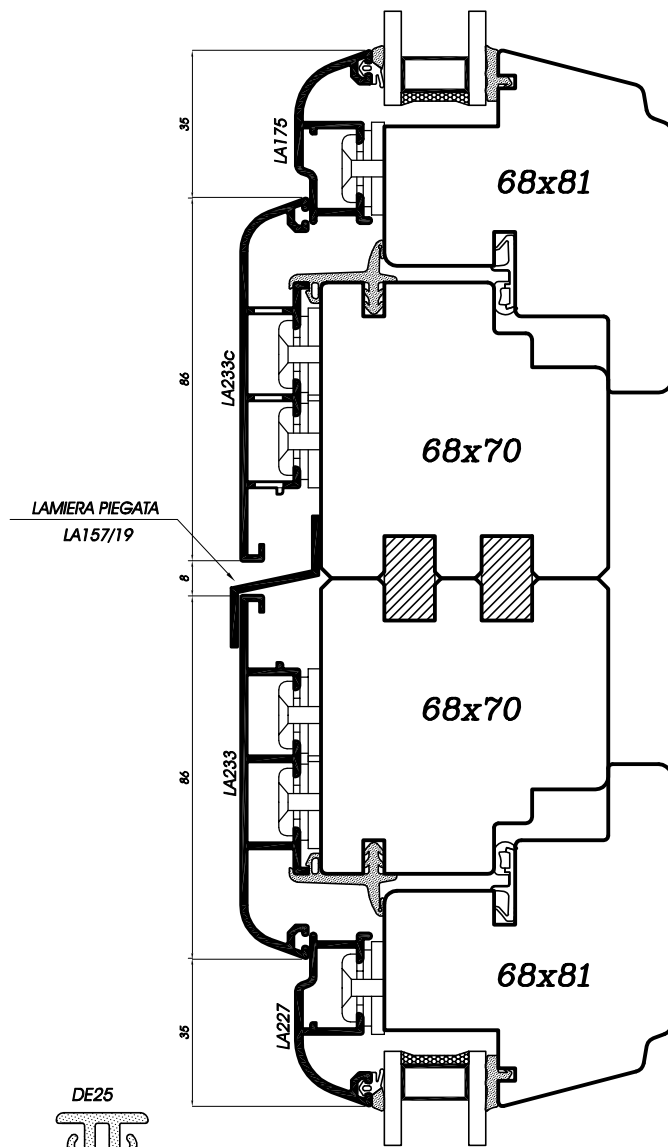
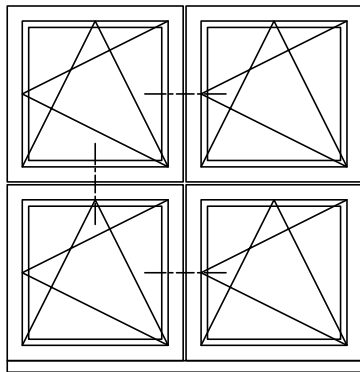

Sezione orizzontale e verticale finestre accoppiate con telaio larghezza 70 mm.  
 Horizontal- und Vertikalschnitt gekoppelte Fenster Holzbreite 70mm  
 Sección horizontal y vertical de ventanas acopladas con anchura del marco de madera de 70 mm  
 Coupe horizontale et verticale accouplement de dormants largeur 70 mm  
 Horizontal and vertical section for connected windows with a frame's breadth of 70 millimeter

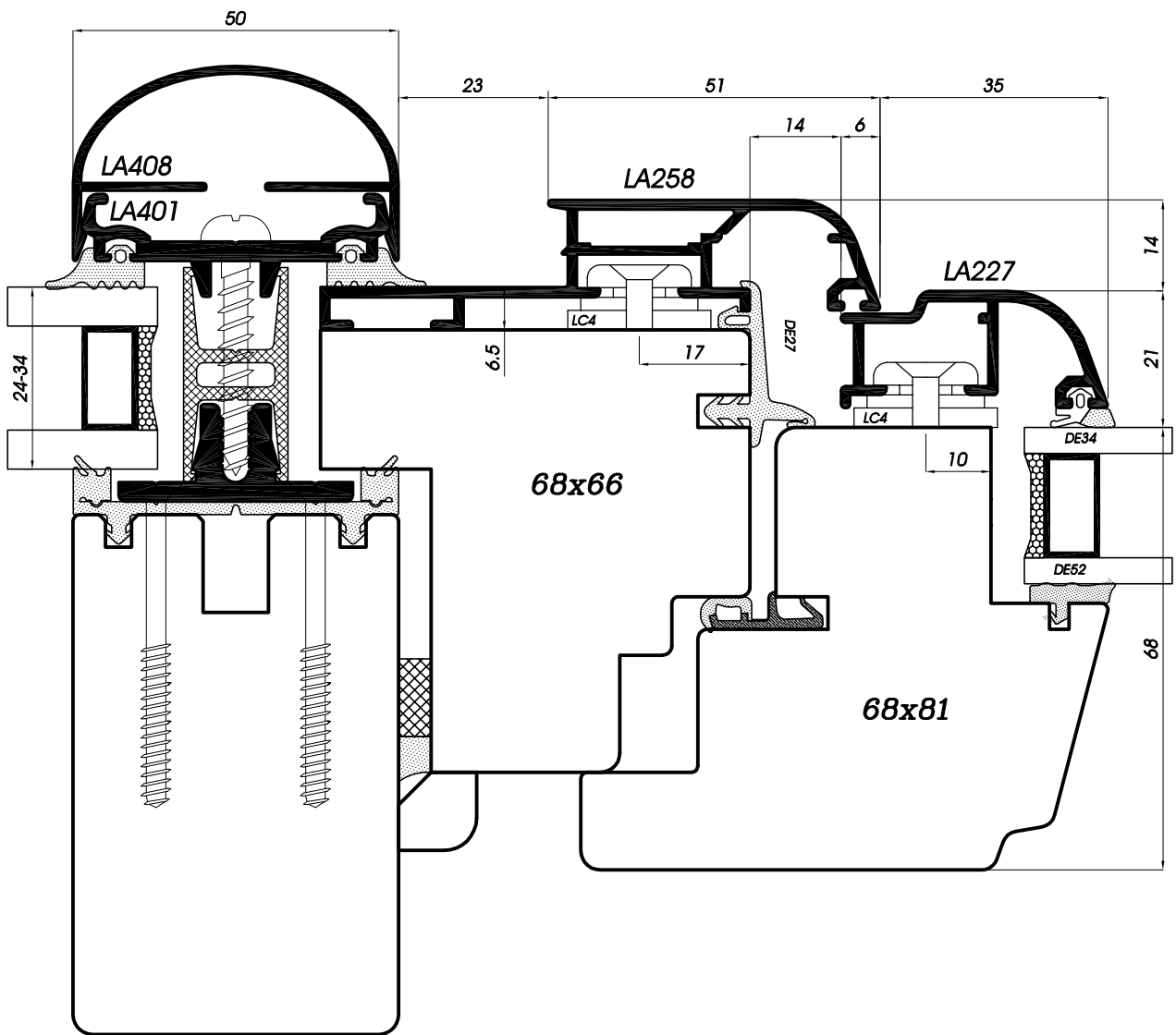

Sezione orizzontale traverso con facciata Unitherm  
 Horizontal Fassade Unitherm - Riegel  
 Sección horizontal travesaños con fachada Unitherm  
 Coupe horizontale traverse - façade Unitherm  
 Horizontal section of the ledgers with Unitherm curtain wall

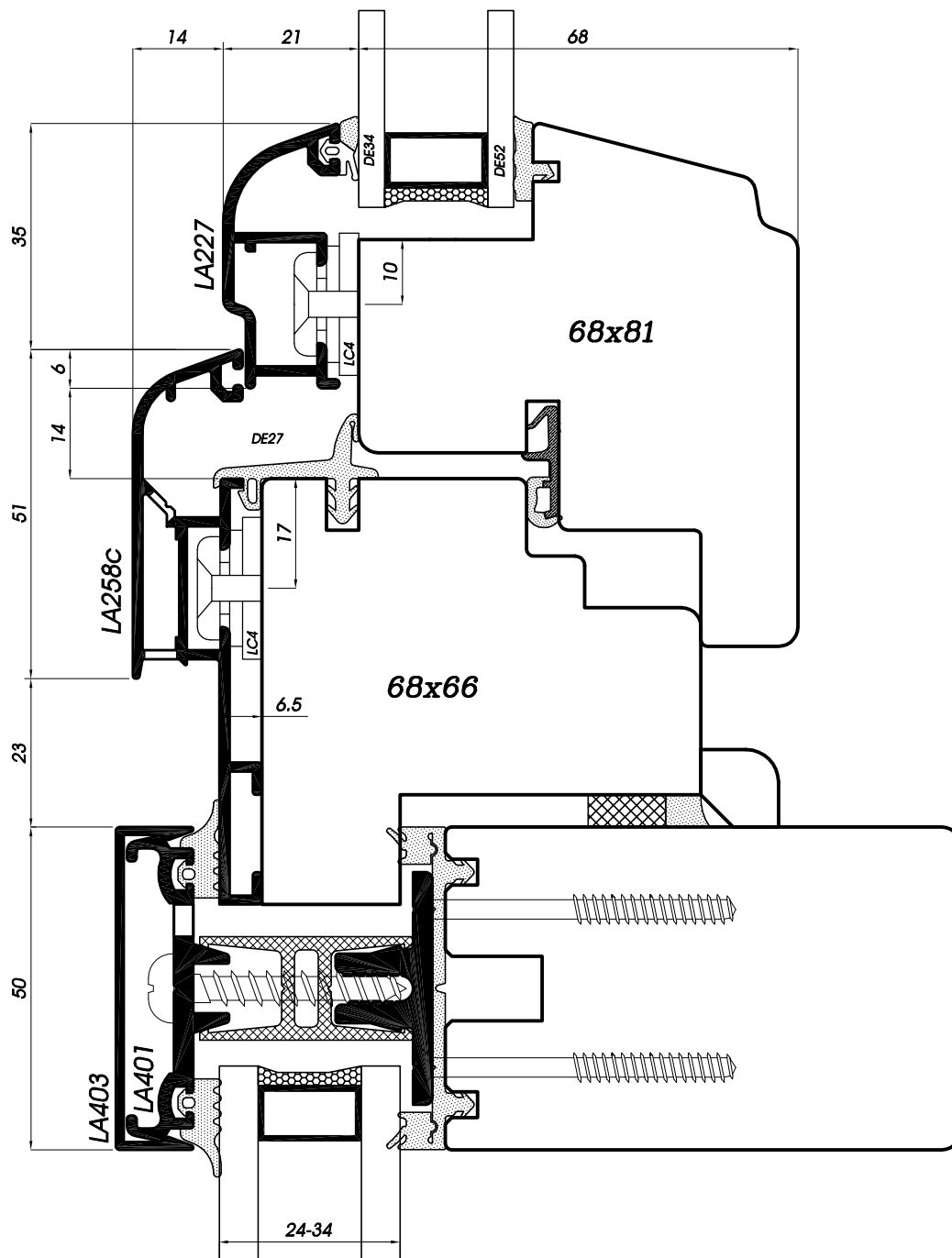

Sezione verticale traversi con facciata Unitherm  
 Vertikalschnitt Fassade Unitherm - Riegel  
 Sección vertical travesaños con fachada Unitherm  
 Coupe verticale traverse - façade Unitherm  
 Vertical section of the ledgers with Unitherm curtain wall

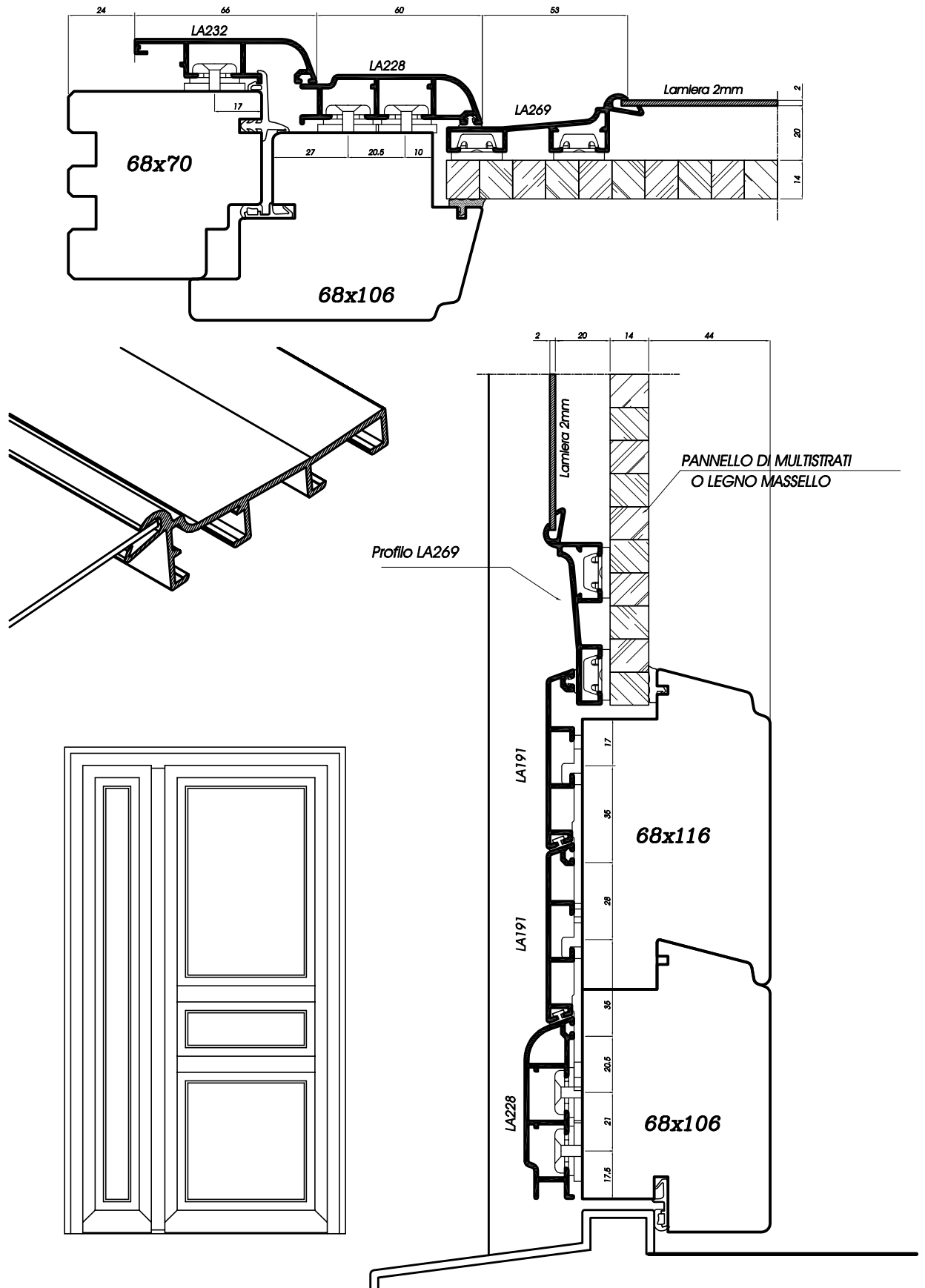

**Pannelli bugnati su misura con profilo LA269**  
**Profilierte Paneelen auf Mass mit Profil LA269**  
**Paneles almohadillados a medida con perfil LA269**  
**Panneaux moulurés sur mesure avec profil LA269**  
**Raised panels on size with profil LA259**

# NUOVO SISTEMA PER PANNELLI BUGNATI

Nuovo sistema per la realizzazione e applicazione di pannelli bugnati su misura

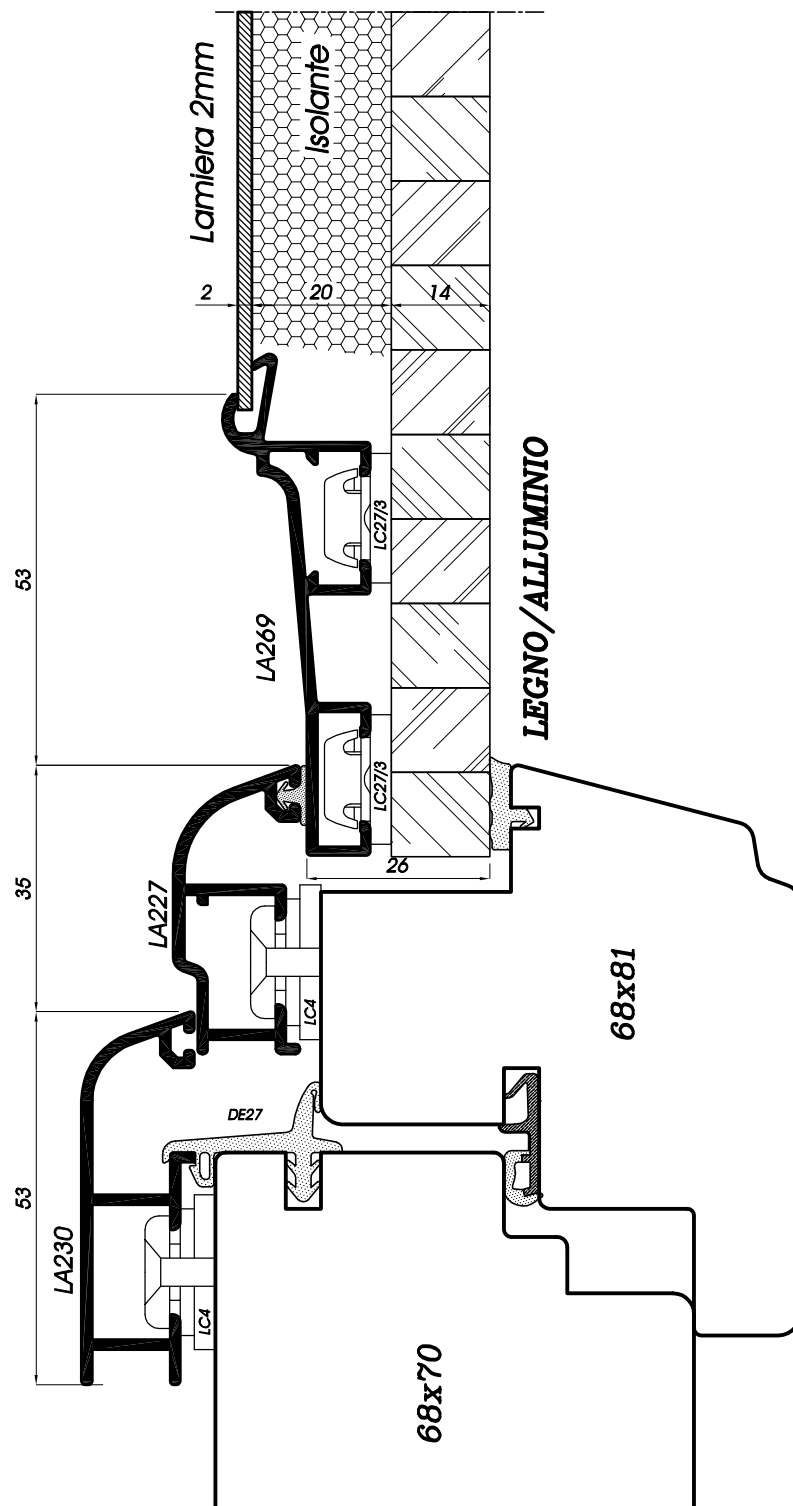

Pannelli bugnati su misura con profilo LA269  
Profilierte Paneelen auf Mass mit Profil LA269  
Paneles almohadillados a medida con perfil LA269  
Panneaux moulurés sur mesure avec profil LA269  
Raised panels on size with profile LA269



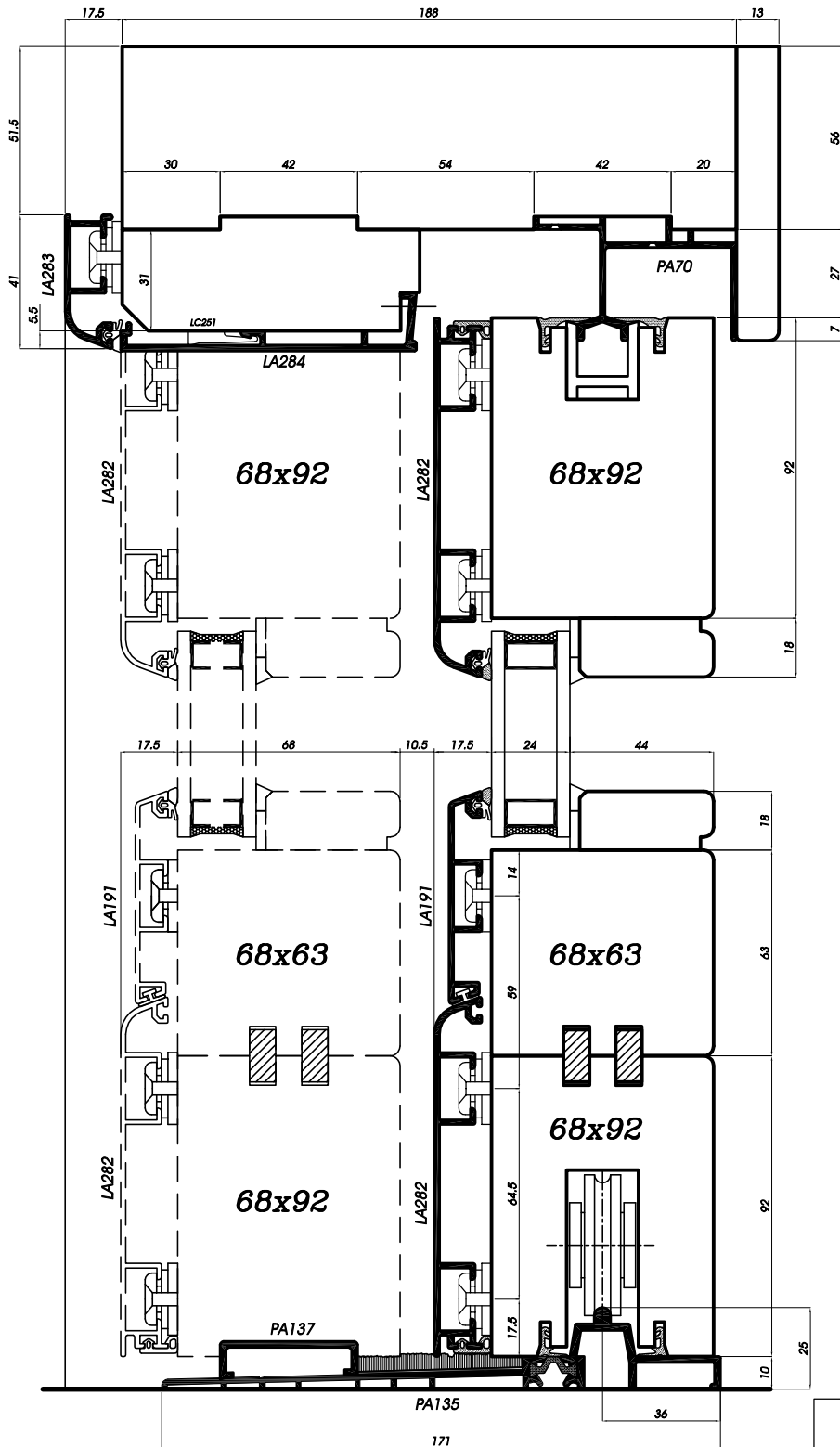

**Sezione verticale serramento alzante scorrevole sp.68mm**  
**Vertikalschnitt Hebe-Schiebe-Tür Holzstärke 68mm**  
**Sección vertical corredera elevadora con madera espesor 68mm**  
**Coupe verticale fenêtre levante-coulissante épaisseur 68mm**  
**Vertical section of the sliding window-door with thickness of 68 millimeter**

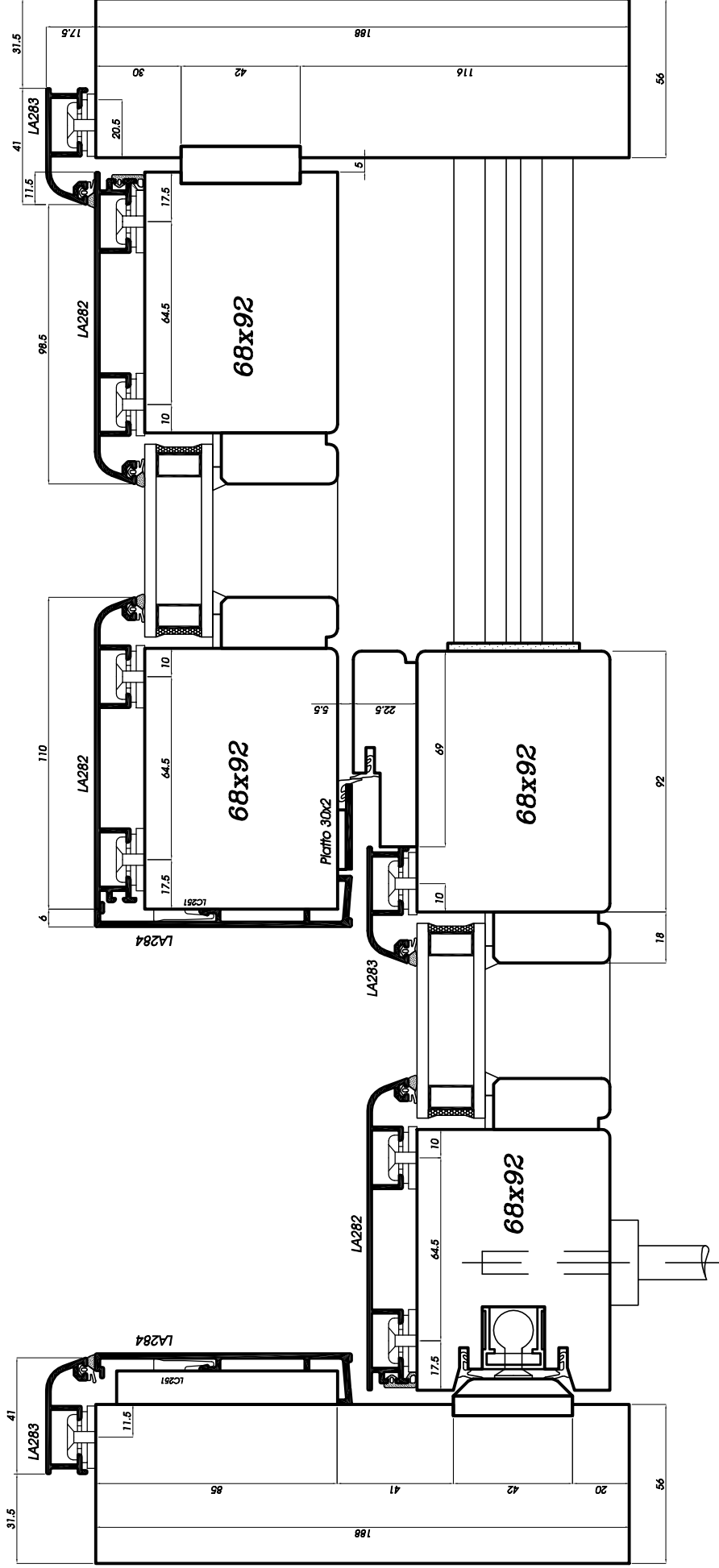

Sezione orizzontale serramento alzante scorrevole sp.68mm  
 Horizontalschnitt Hebe-Schiebe-Tür Holzstärke 68mm  
 Sección horizontal corredera elevadora con madera espesor 68mm  
 Coupe horizontale fenêtre levante-couissante épaisseur 68mm  
 Horizontal section of the sliding window-door with thickness of 68 millimeter

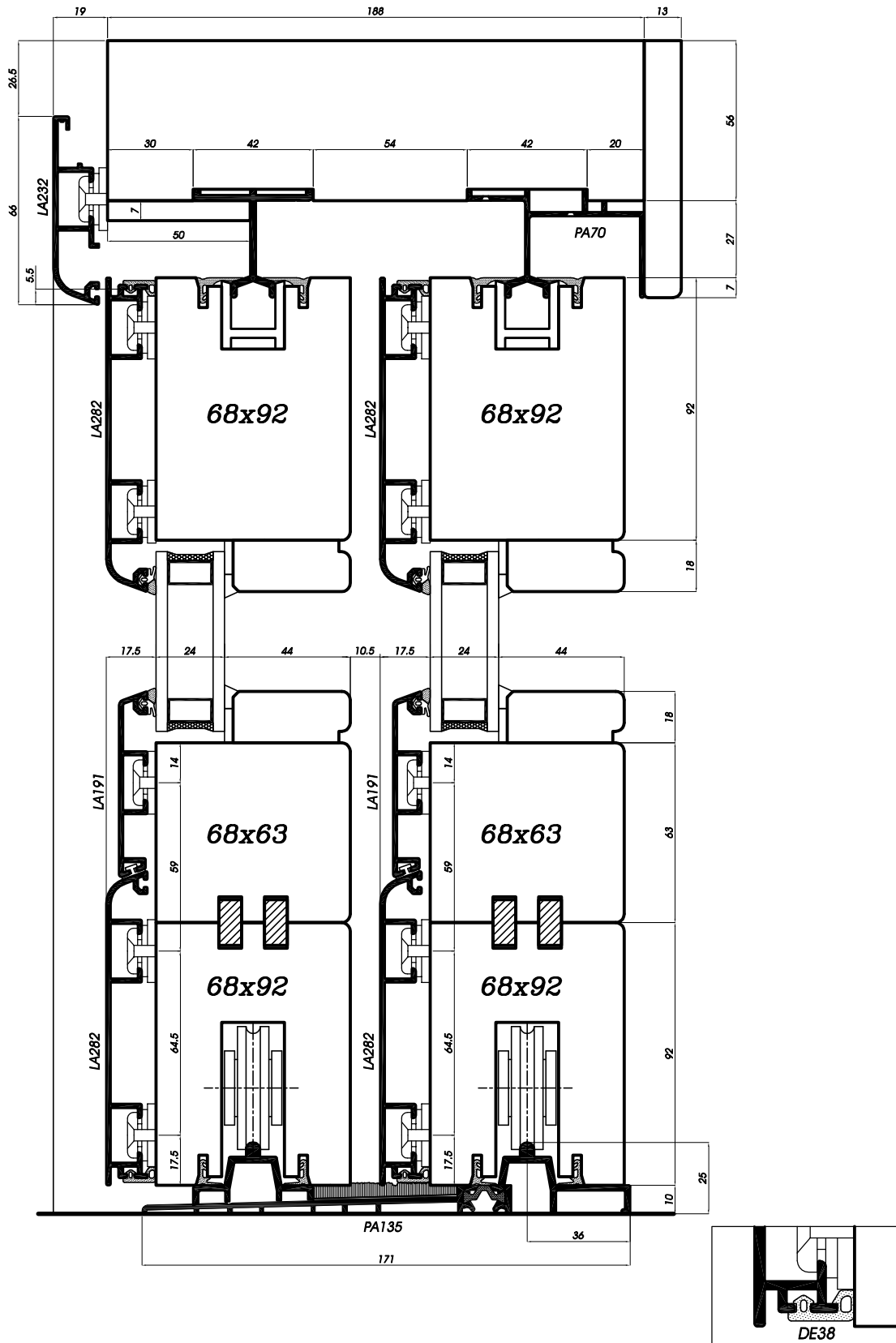

Sezione verticale serramento alzante scorrevole sp.68mm con doppia anta mobile  
 Vertikalschnitt Hebe-Schiebe-Tür, zwei-flügelig, Holzstärke 68mm  
 Sección vertical corredera elevadora con madera espesor 68mm  
 Coupe verticale fenêtre levant-coulissante épaisseur 68 mm - 2 vantaux mobiles  
 Vertical section of the sliding window-door with a thickness of 68mm and a double mobile wing

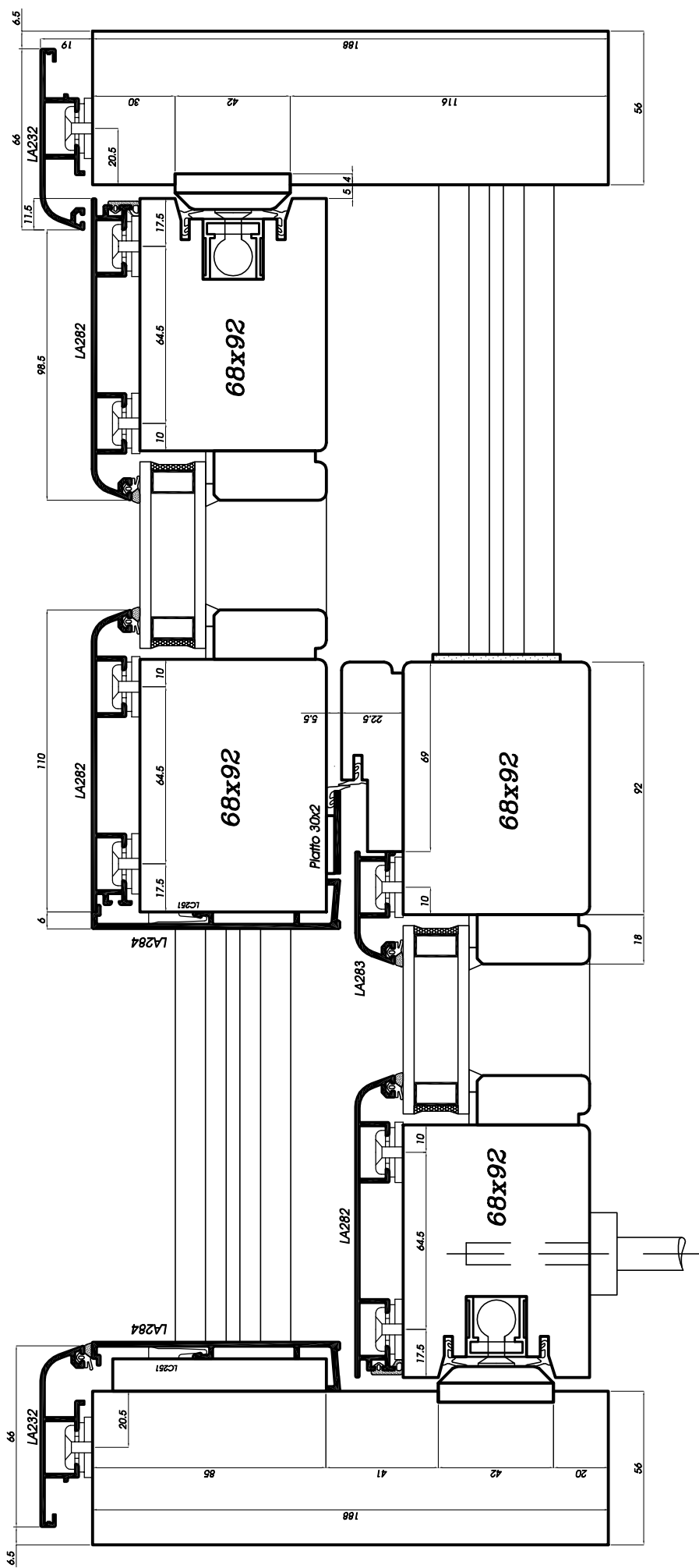

Sezione orizzontale serramento alzante scorrevole sp.68mm con doppia anta mobile  
 Horizontalschnitt Hebe-Schiebe-Tür, 2-flg., Holzstärke 68mm  
 Sección horizontal corredera elevadora con madera espesor 68mm  
 Coupe horizontale fenêtre levant-coulissante épaisseur 68 mm - 2 vantaux mobiles  
 Horizontal section of the sliding window-door with a thickness of 68 mm and a double mobile wing

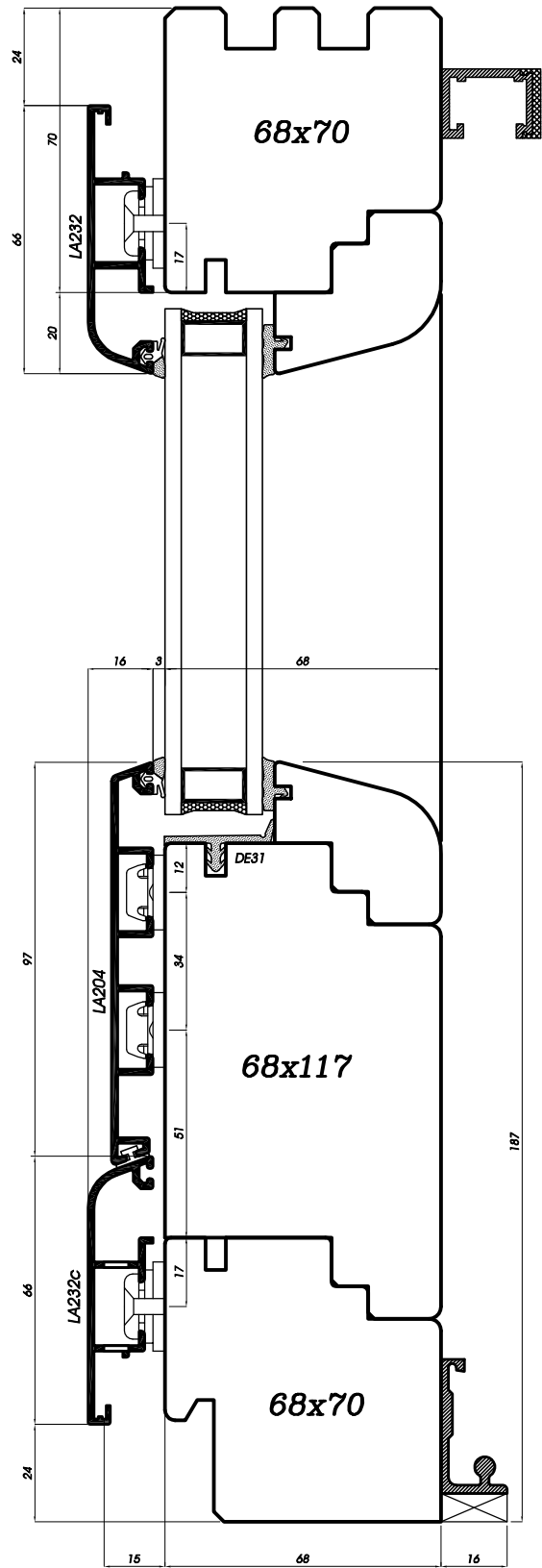
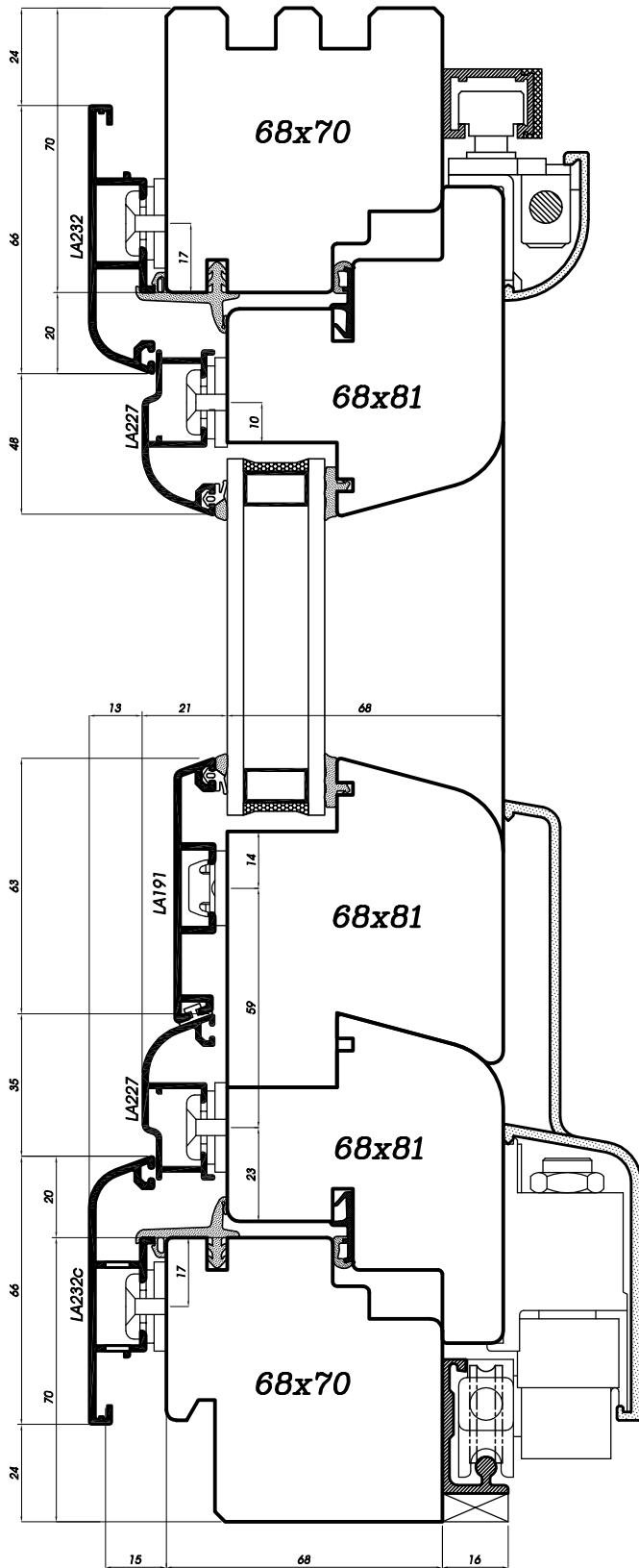

Sezione verticale portafinestra con scorrevole parallelo  
 Vertikalschnitt Parallelschiebekipptür  
 Sección vertical puertaventana con corredera paralela  
 Coupe verticale porte-fenêtre coulissante à translation  
 Vertical section of the parallel sliding window-door

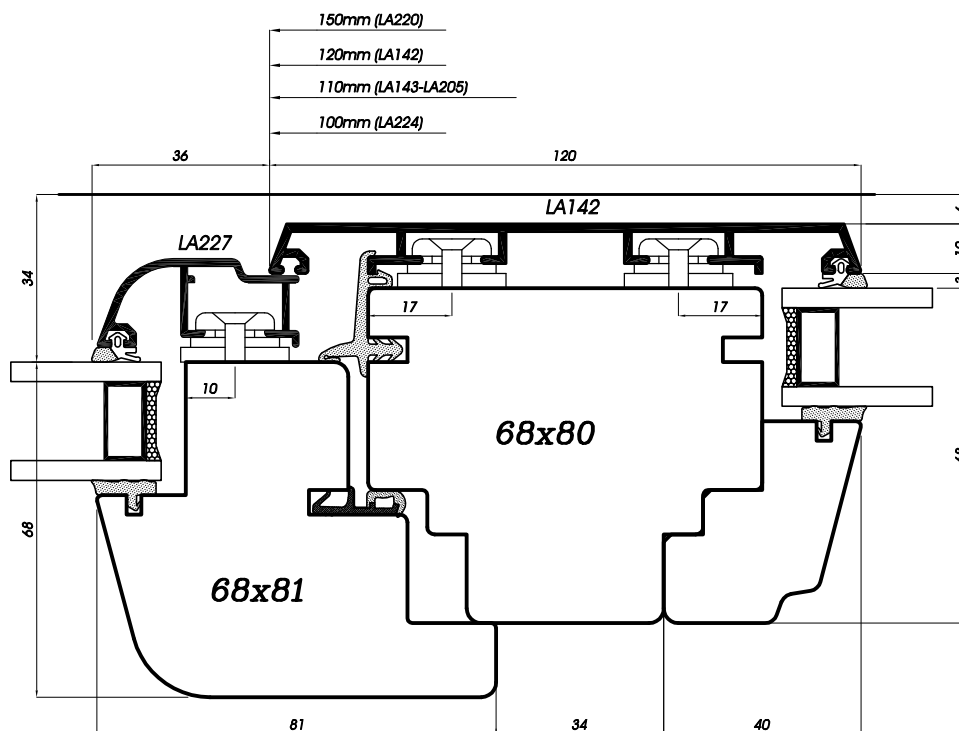
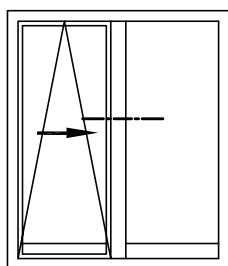
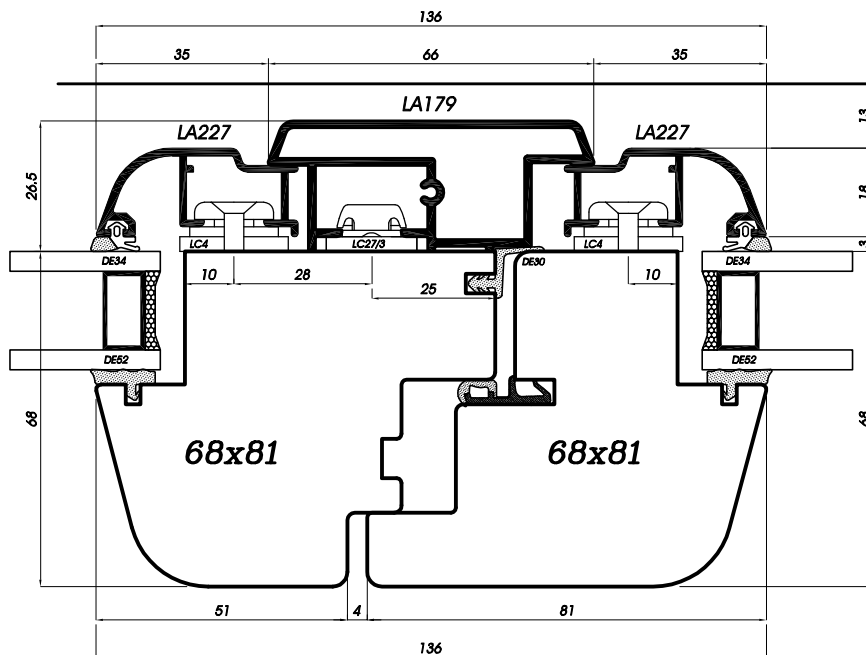
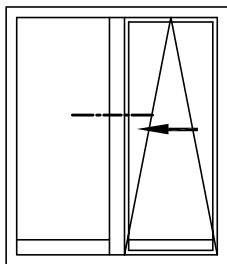

Sezione orizzontale portafinestra con scorrevole parallelo  
 Horizontalschnitt Parallelschiebekipptür  
 Sección horizontal puertaventana con corredera paralela  
 Coupe horizontale porte-fenêtre coulissante à translation  
 Horizontal section of the parallel sliding window-door

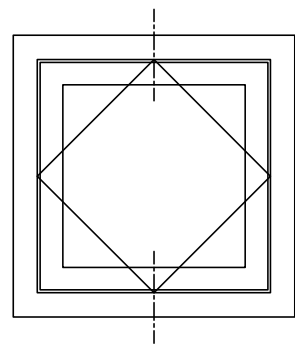
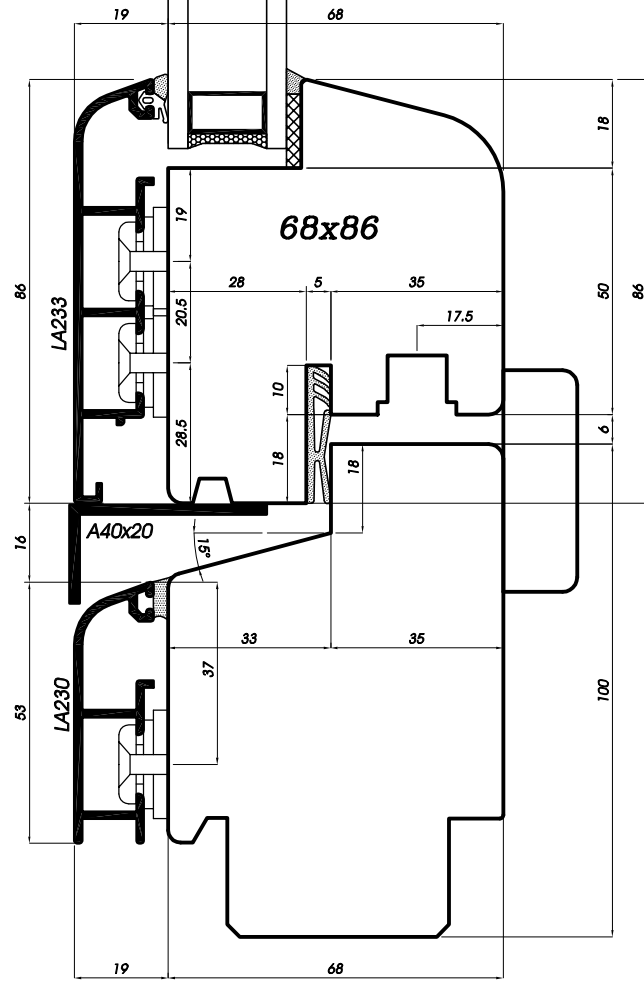
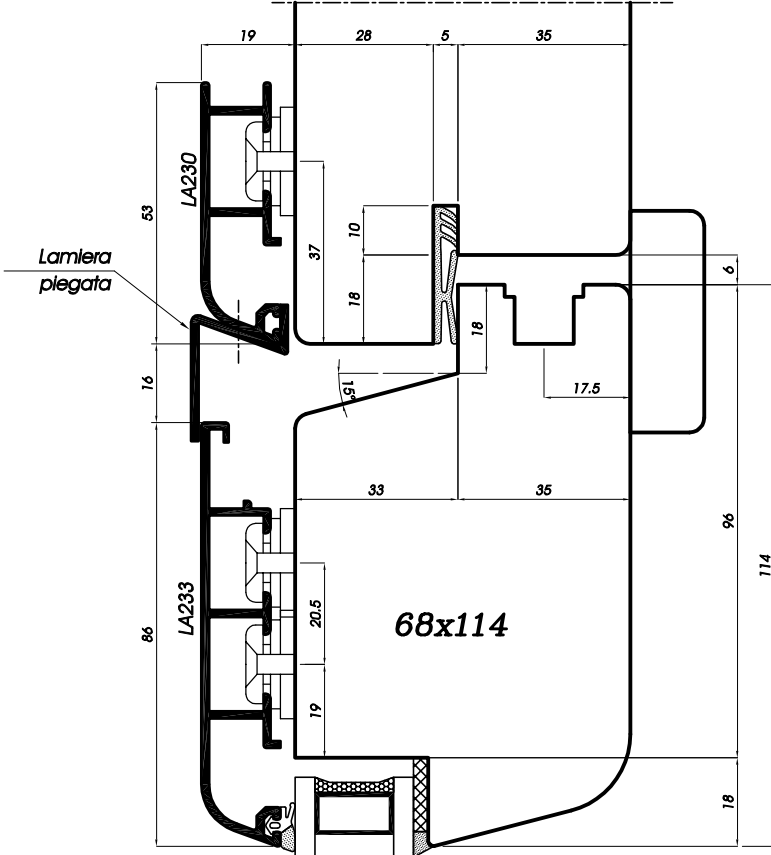

Sezione verticale bilico orizzontale  
 Vertikalschnitt Schwingflügel  
 Sección vertical de basculante horizontal  
 Coupe verticale fenêtre basculante  
 Horizontal section of the horizontal bascule window

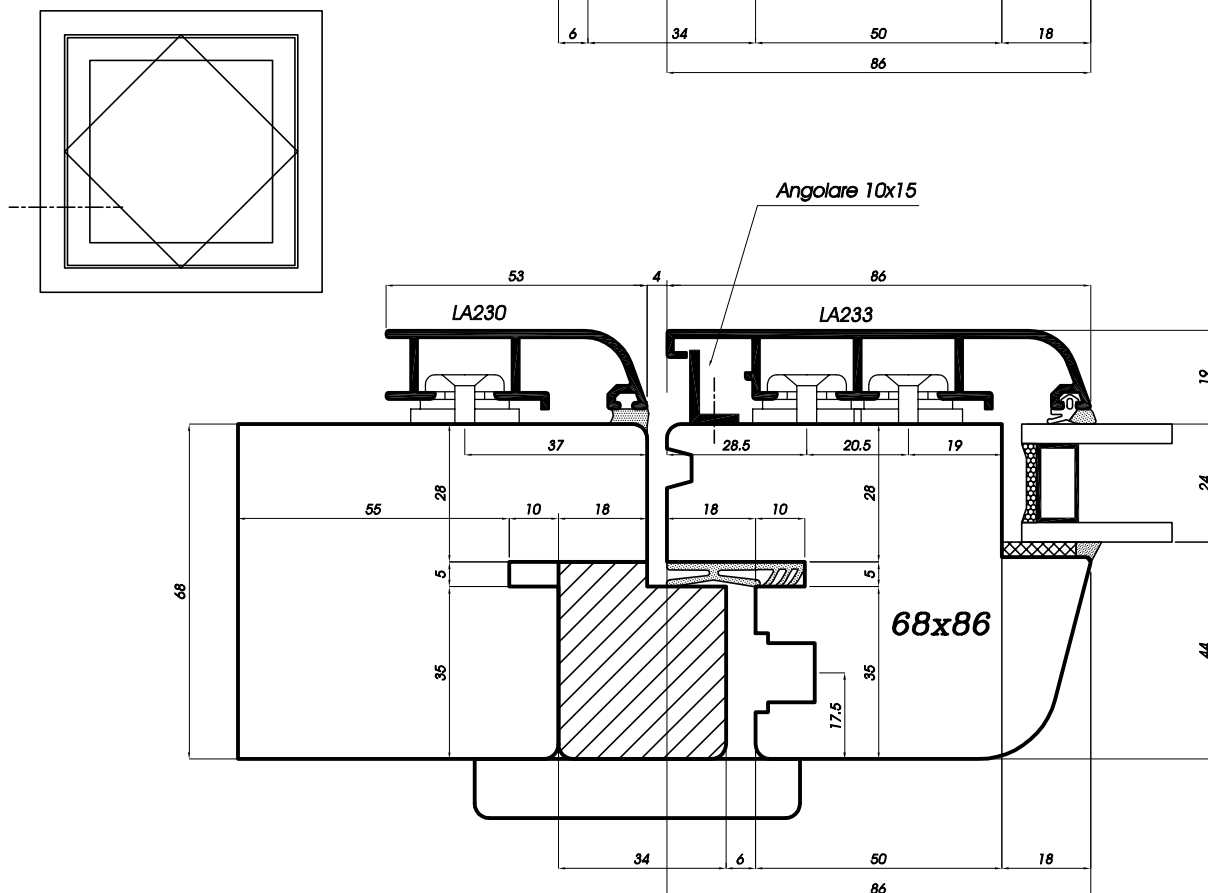
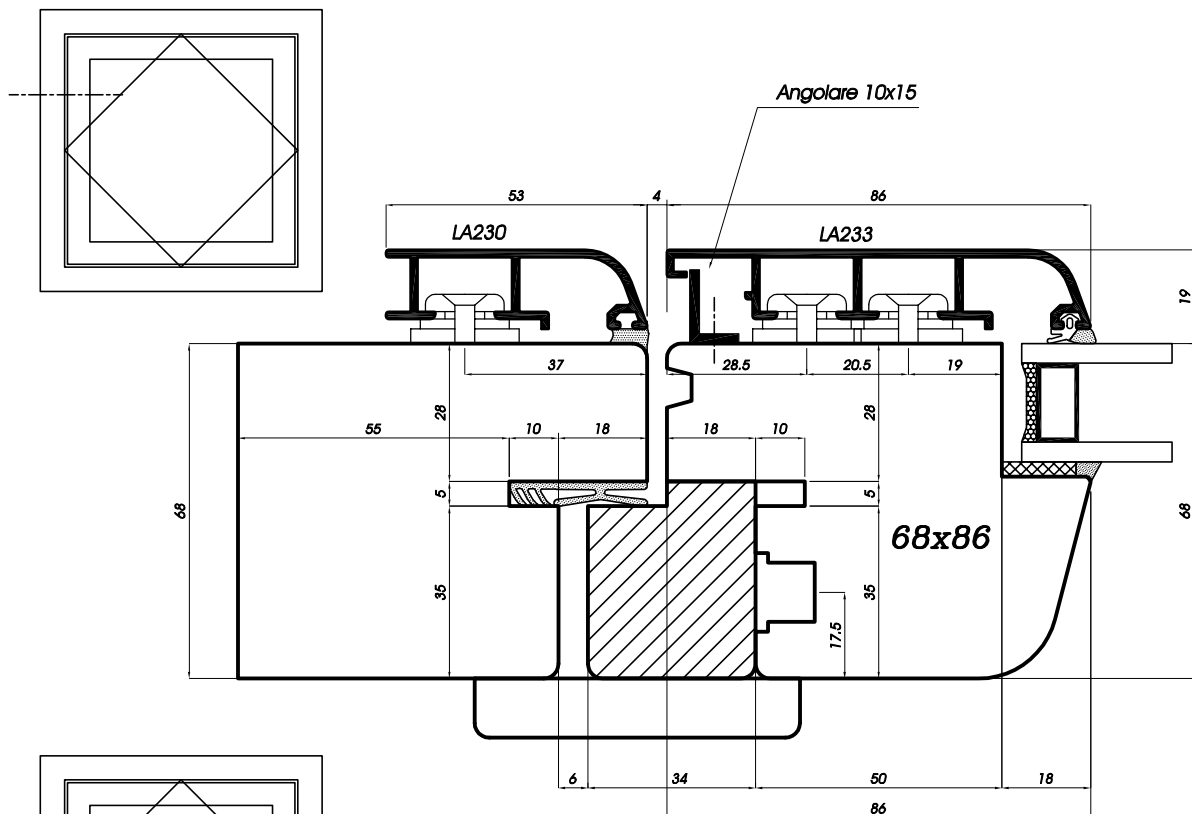

**Sezione orizzontale bilico orizzontale**  
**Horizontalschnitt Schwingflügel**  
**Sección horizontal de basculante horizontal**  
**Coupe horizontale fenêtre basculante**  
**Horizontal section of the horizontal bascule window**



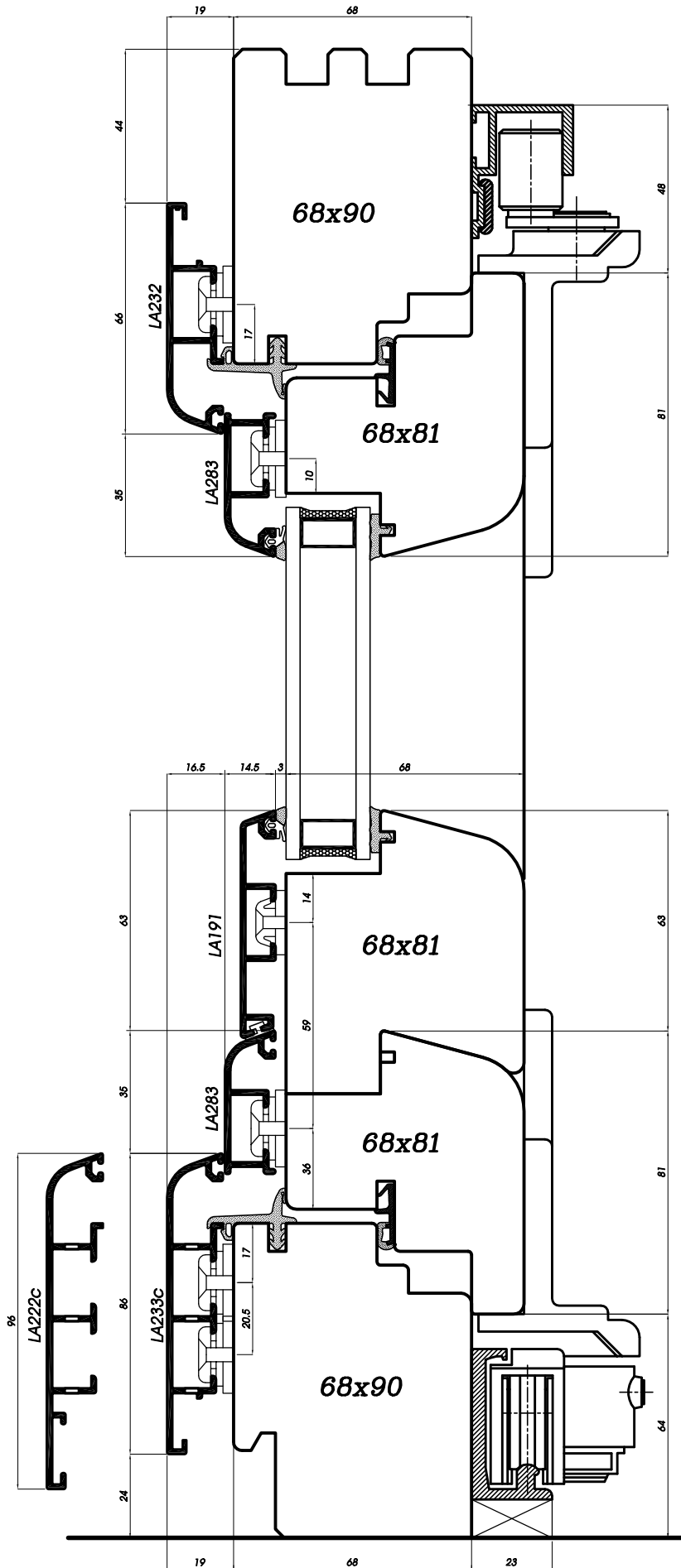

Sezione verticale serramento a libro  
 Vertikalschnitt Falftür  
 Sección vertical de cerramiento a libro  
 Coupe verticale fenêtre coulissante pliante  
 Vertical section of the sliding-folding window

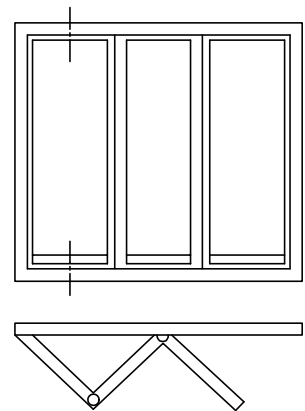

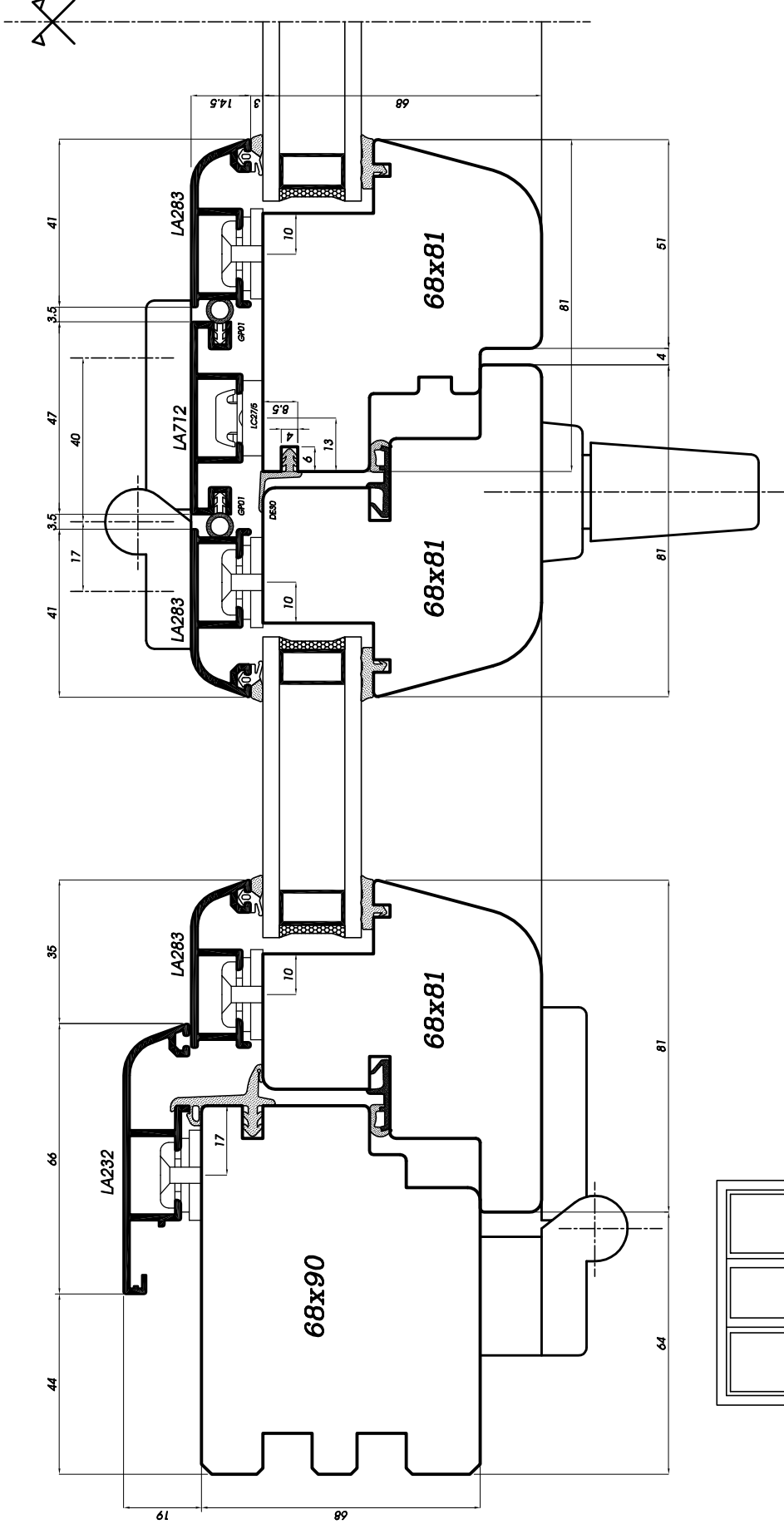

**Sezione orizzontale serramento a libro**  
**Horizontalschnitt Falttür**  
**Sección horizontal de cerramiento a libro**  
**Coupe horizontale fenêtre coulissante pliante**  
**Horizontal section of the sliding-folding window**

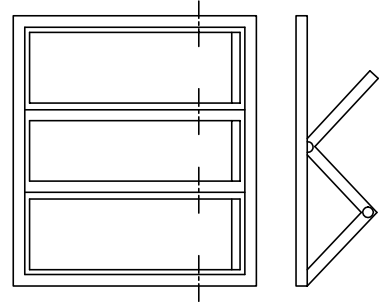

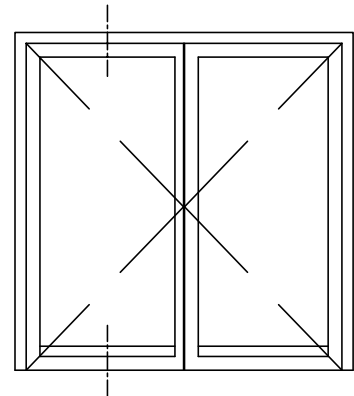
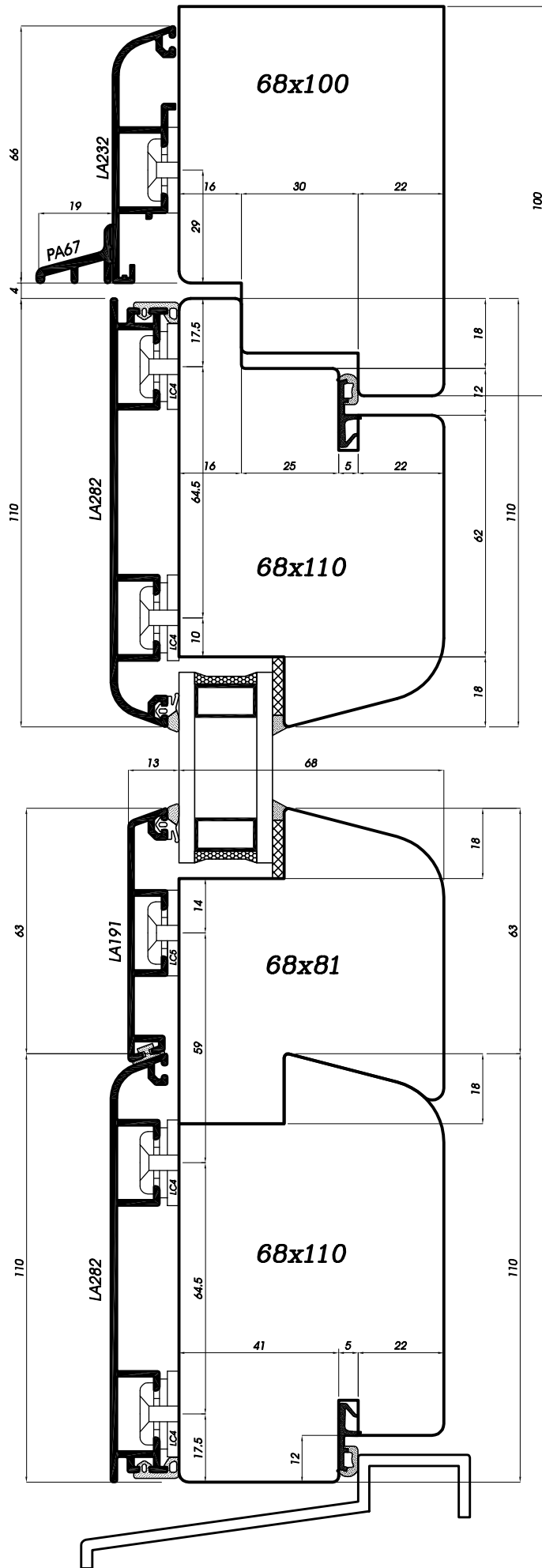

Sezione verticale serramento con apertura a sporgere  
 Vertikalschnitt Tür nach außen öffnend  
 Sección vertical de cerramiento con apertura hacia el exterior  
 Coupe verticale fenêtre avec ouverture vers l'extérieur  
 Vertical section of top-hinged window



Nuova cerniera regolabile nelle tre direzioni!

- FS06/7F -Argento
  - FS06/6F -Bronzo scuro
  - FS06/7E -Bianco RAL9016
  - FS06/9F -GREZZA
- Pontafici: Legno tenero kg.100  
Legno duro kg.120

Distanziali cod.1.946.6681

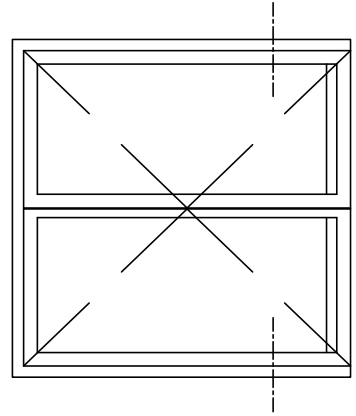
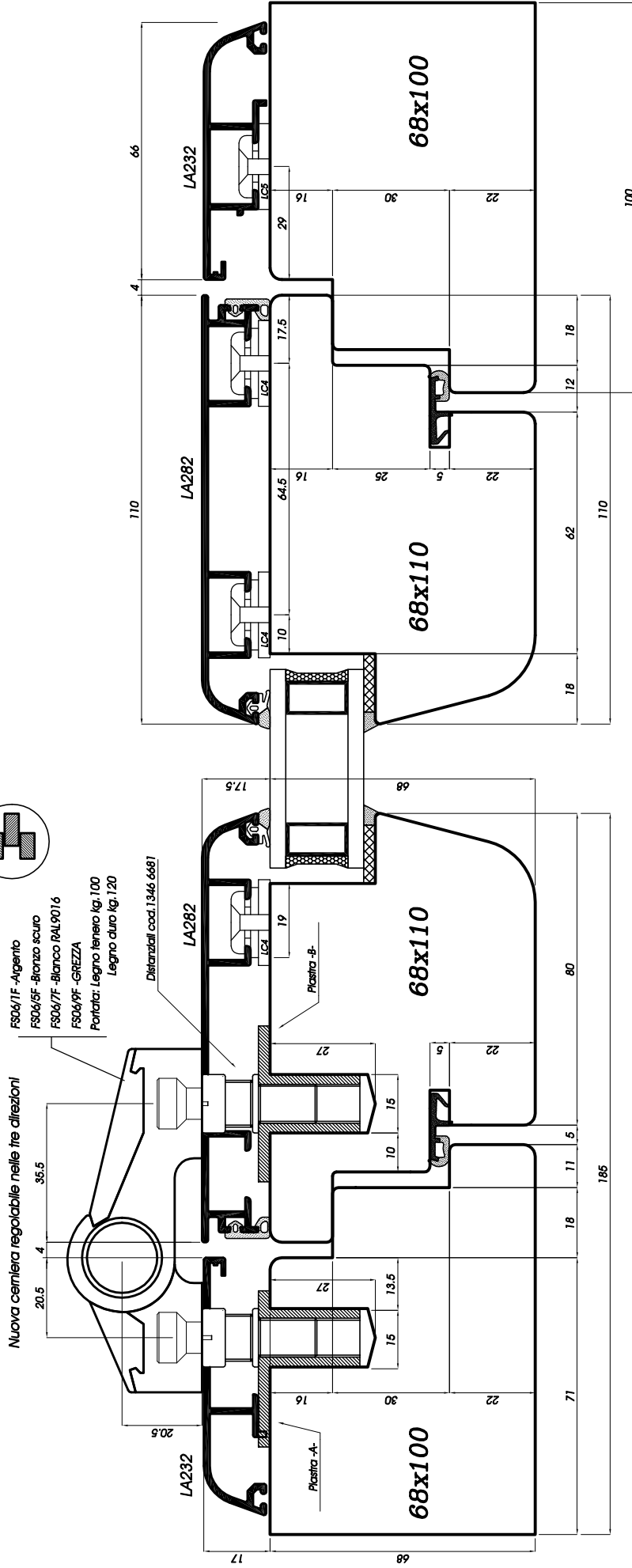

Sezione orizzontale serramento con apertura a sporgere  
 Horizontalschnitt Tür nach außen öffnend  
 Sección horizontal de cerramiento con apertura hacia el exterior  
 Coupe horizontale fenêtre avec ouverture vers l'extérieur  
 Horizontal section of top-hinged window

**ATTENZIONE:**

per il sistema Soft-Line  
inserire sei distanziali  
cod. 1346 6681

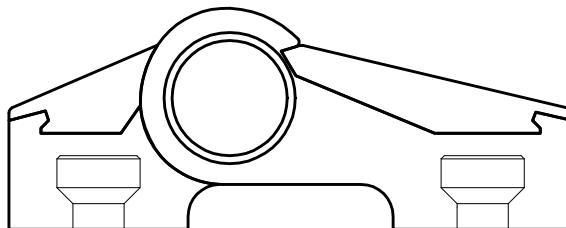

Nuova cerniera regolabile nelle tre direzioni con chiave LD30

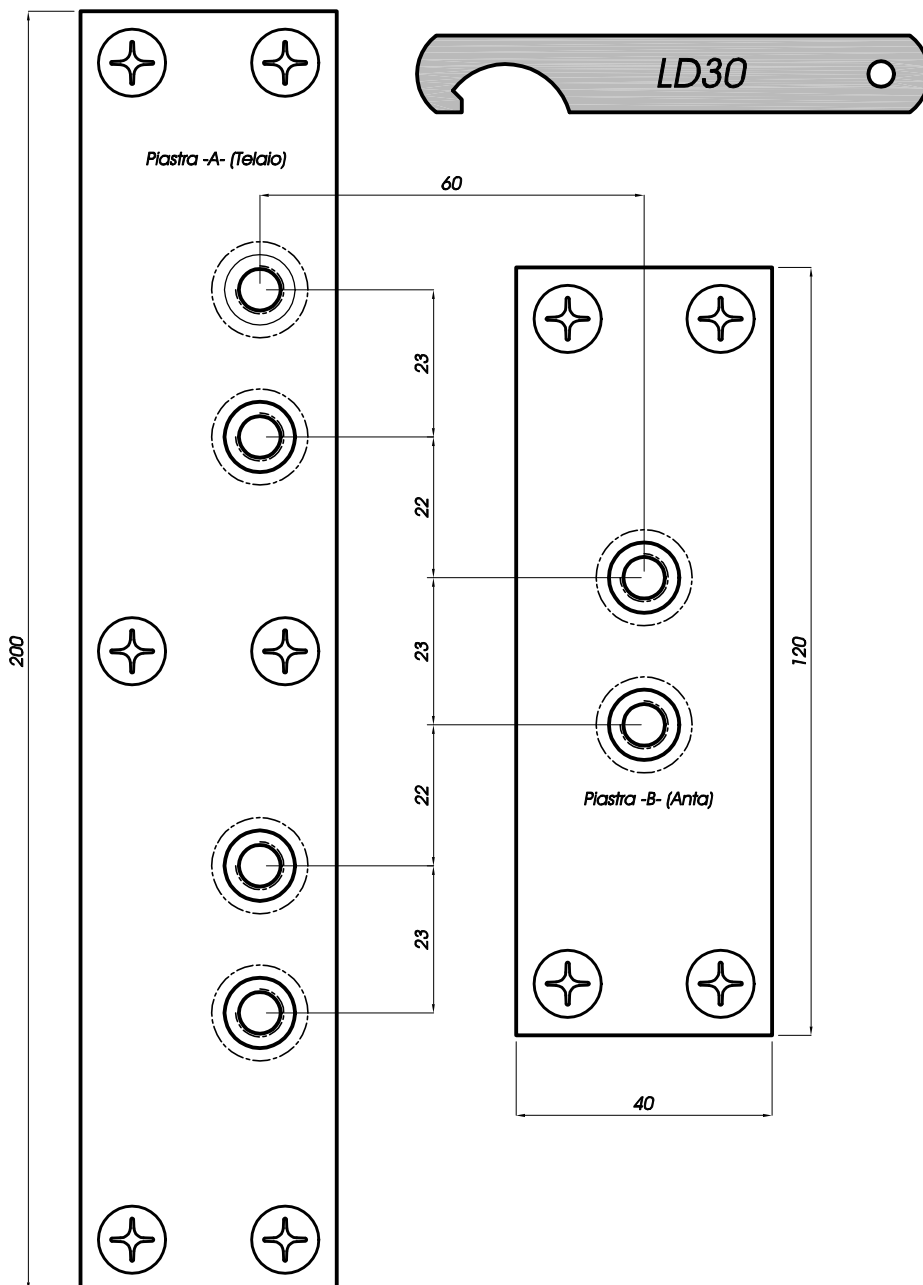

**Cerniera per apertura a sporgere**  
**Scharniere für nach Aussen gehende Öffnung**  
**Bisagra para apertura hacia el exterior**  
**Charnière pour ouverture vers l'extérieur**  
**H hinge for the projected opening**

*Sistema*

*VERBUND SOFT-Line*

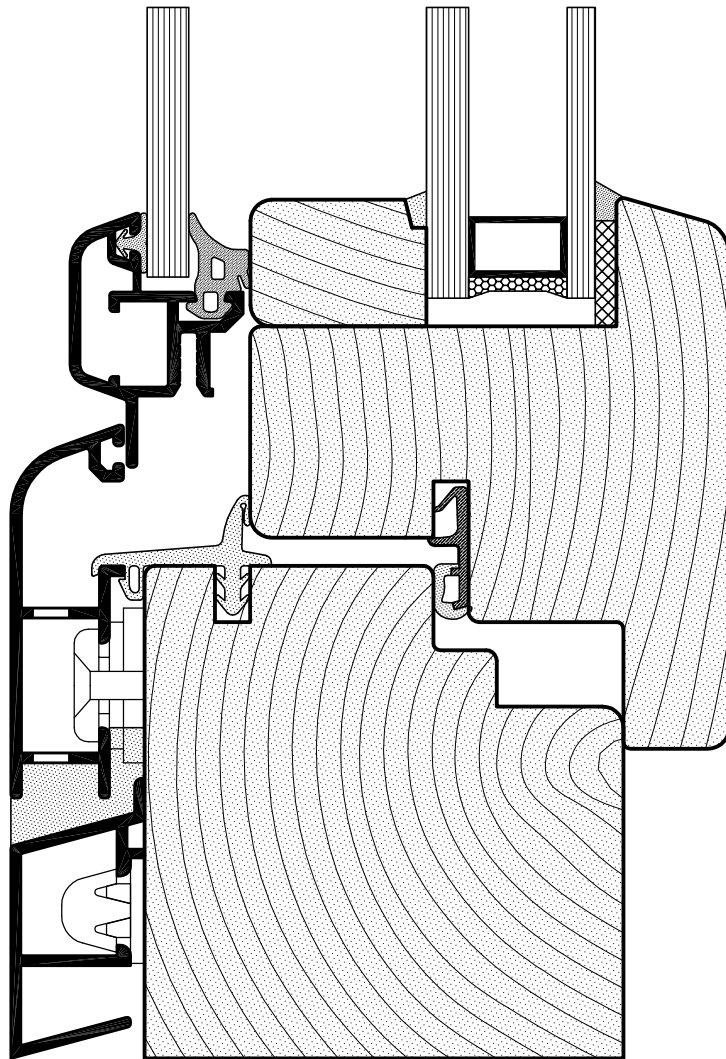

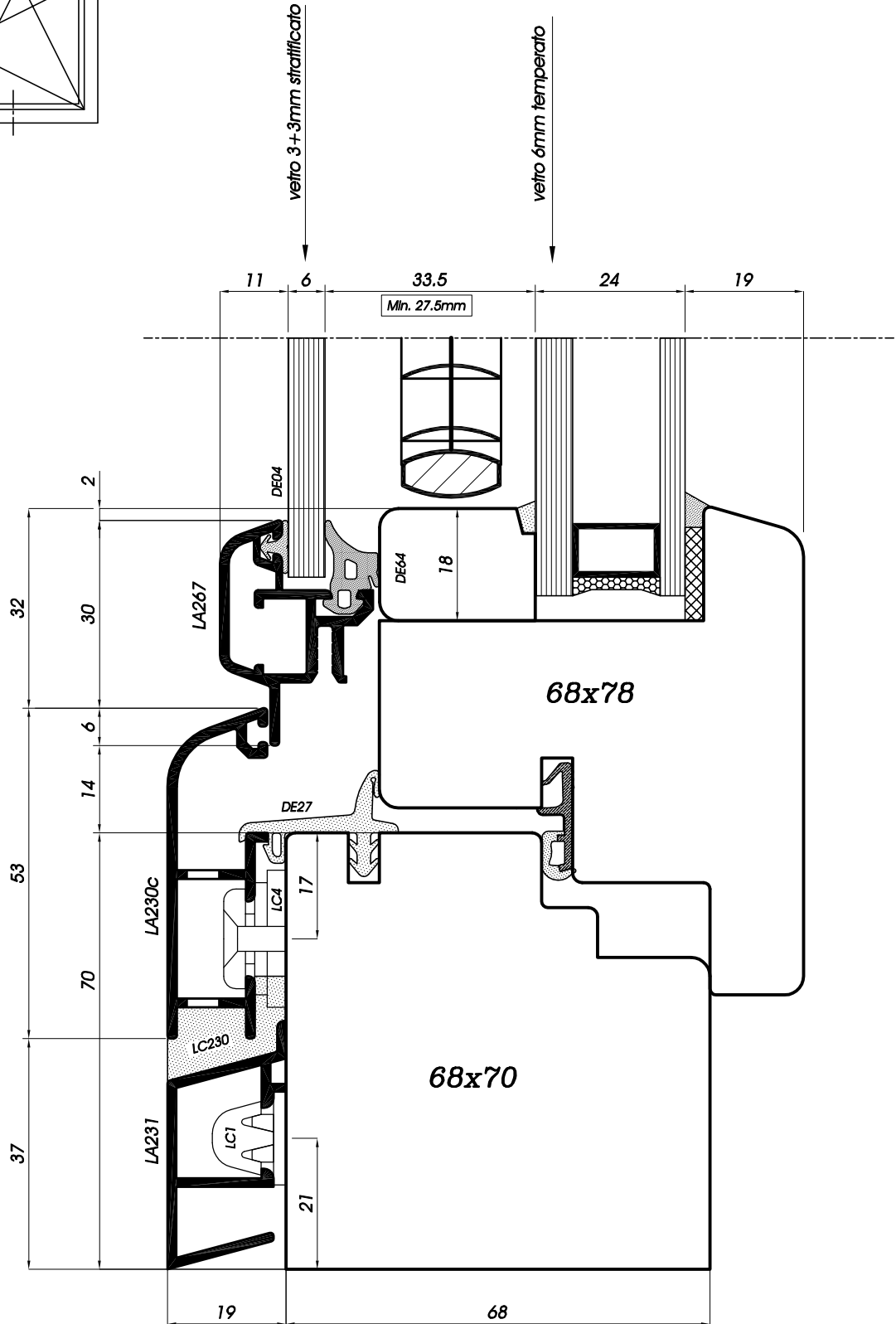
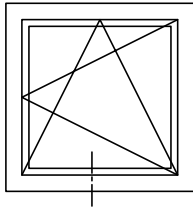

**Sezione verticale traverso inferiore finestra**  
**Vertikalschnitt Fenster quer unten**  
**Sección vertical travesaño inferior de la ventana**  
**Coupe verticale traverse inférieure fenêtre**  
**Vertical section of the window's lower ledge**

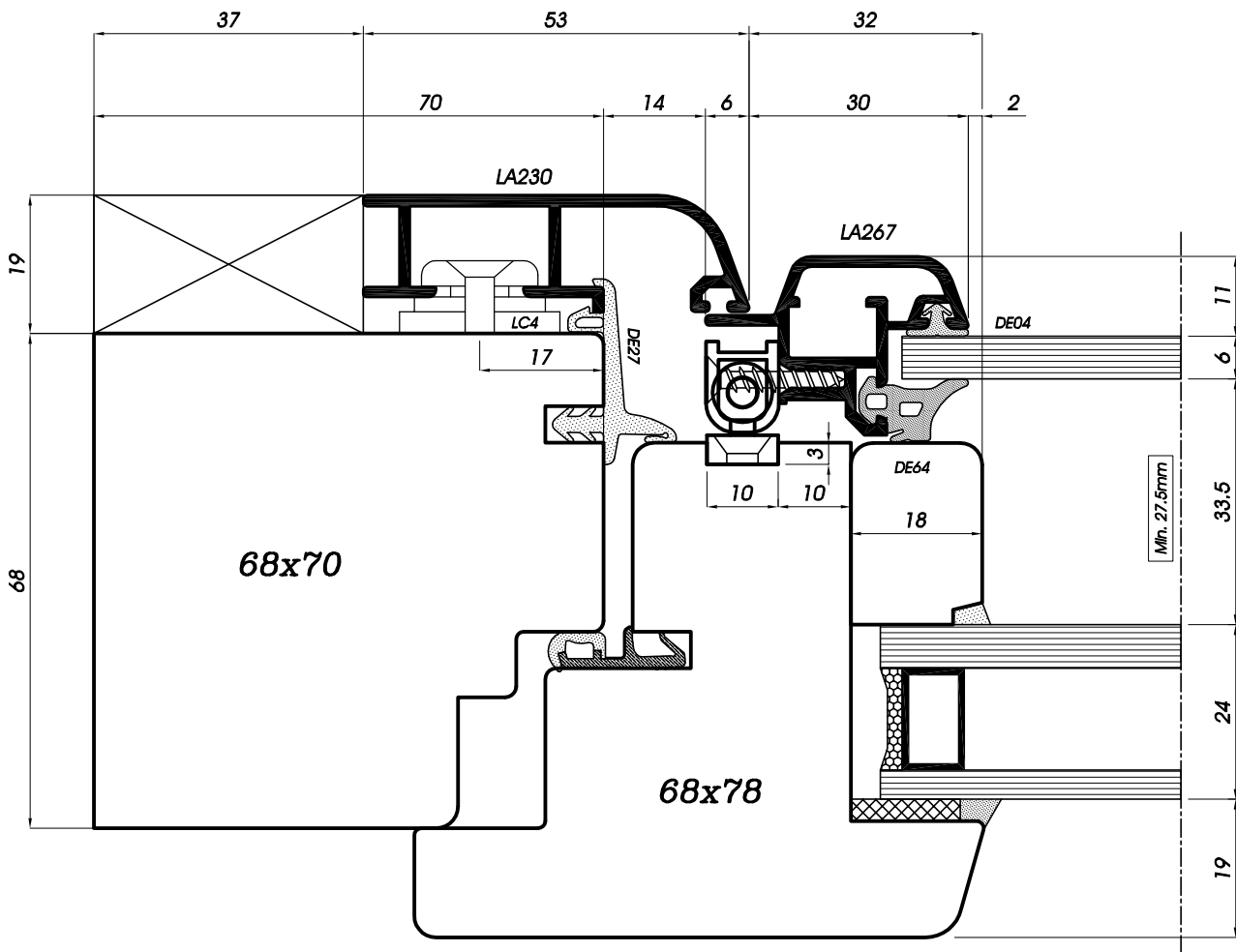
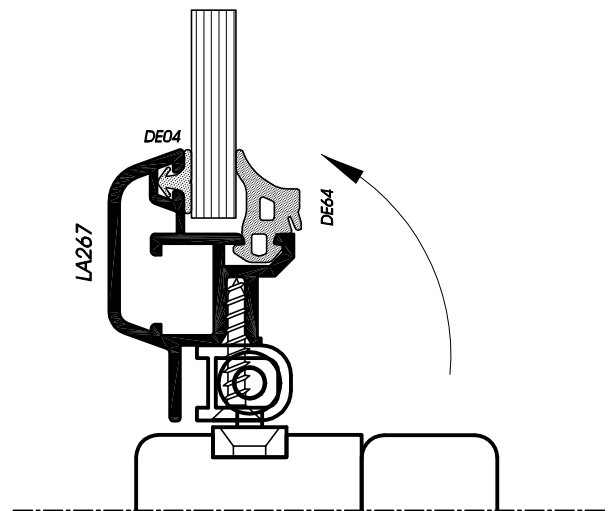
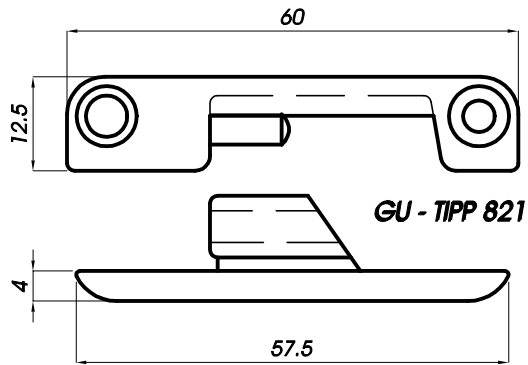
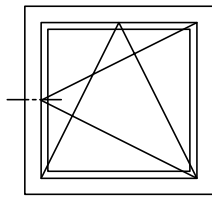

Sezione orizzontale montante laterale  
 Horizontalschnitt senkrecht seitlich  
 Sección horizontal montante lateral  
 Coupe horizontale du montant latéral  
 Horizontal section lateral jamb



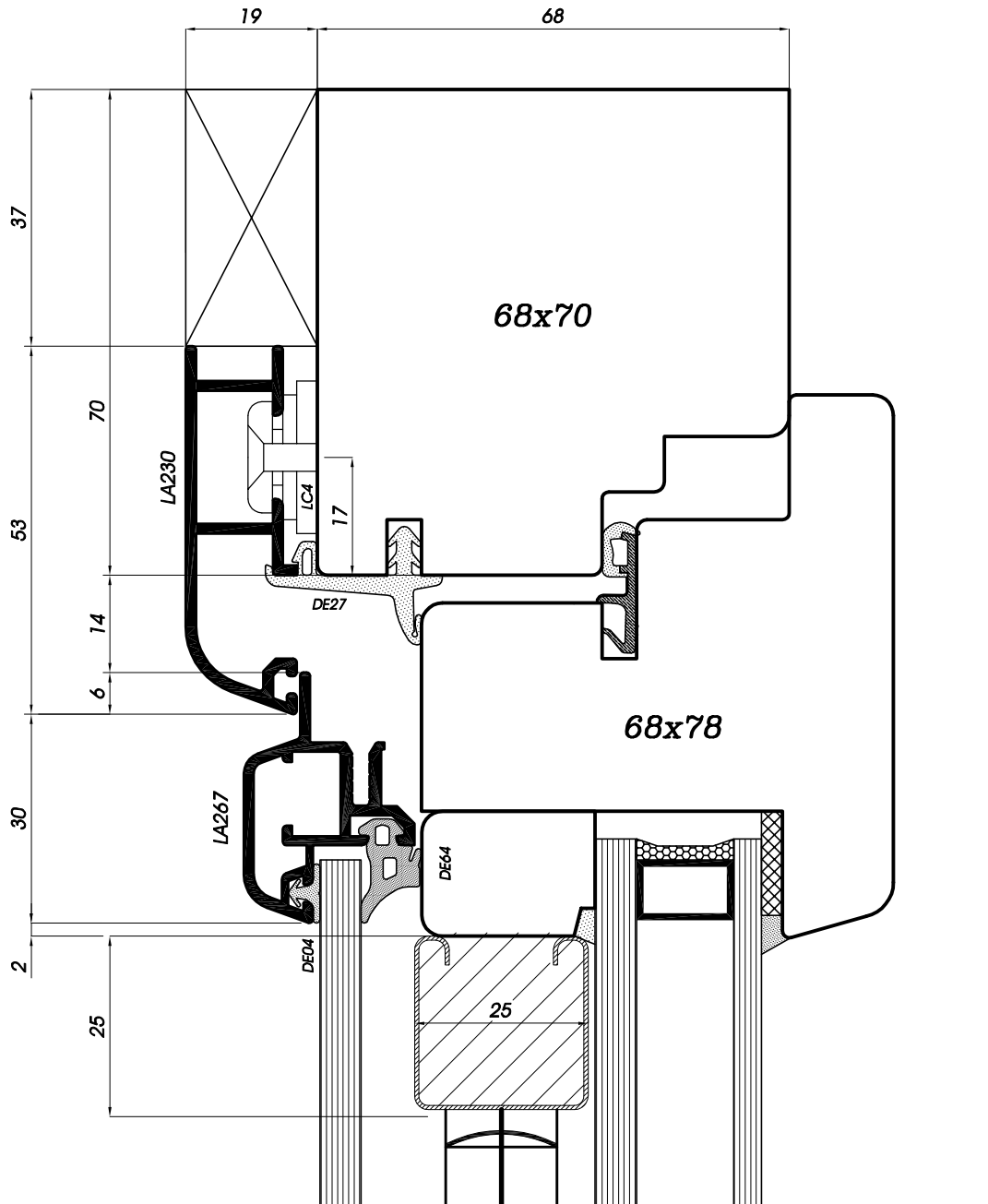
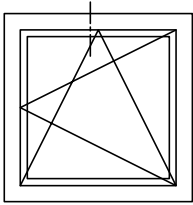

**Sezione verticale traverso superiore finestra**  
**Vertikalschnitt Fenster quer oben**  
**Sección vertical travesaño superior de la ventana**  
**Coupe verticale traverse supérieure fenêtre**  
**Vertical section window's upper ledger**

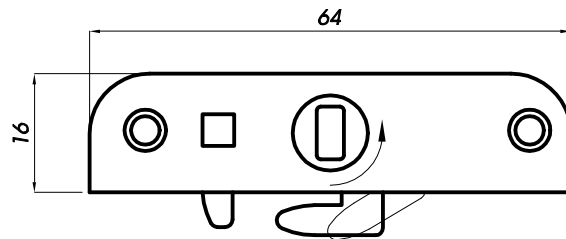
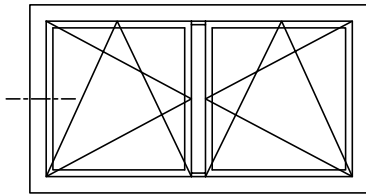

GU - TOPP 47

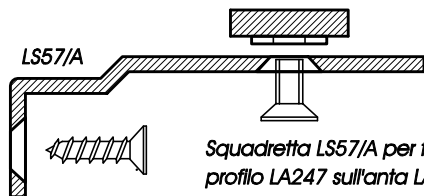
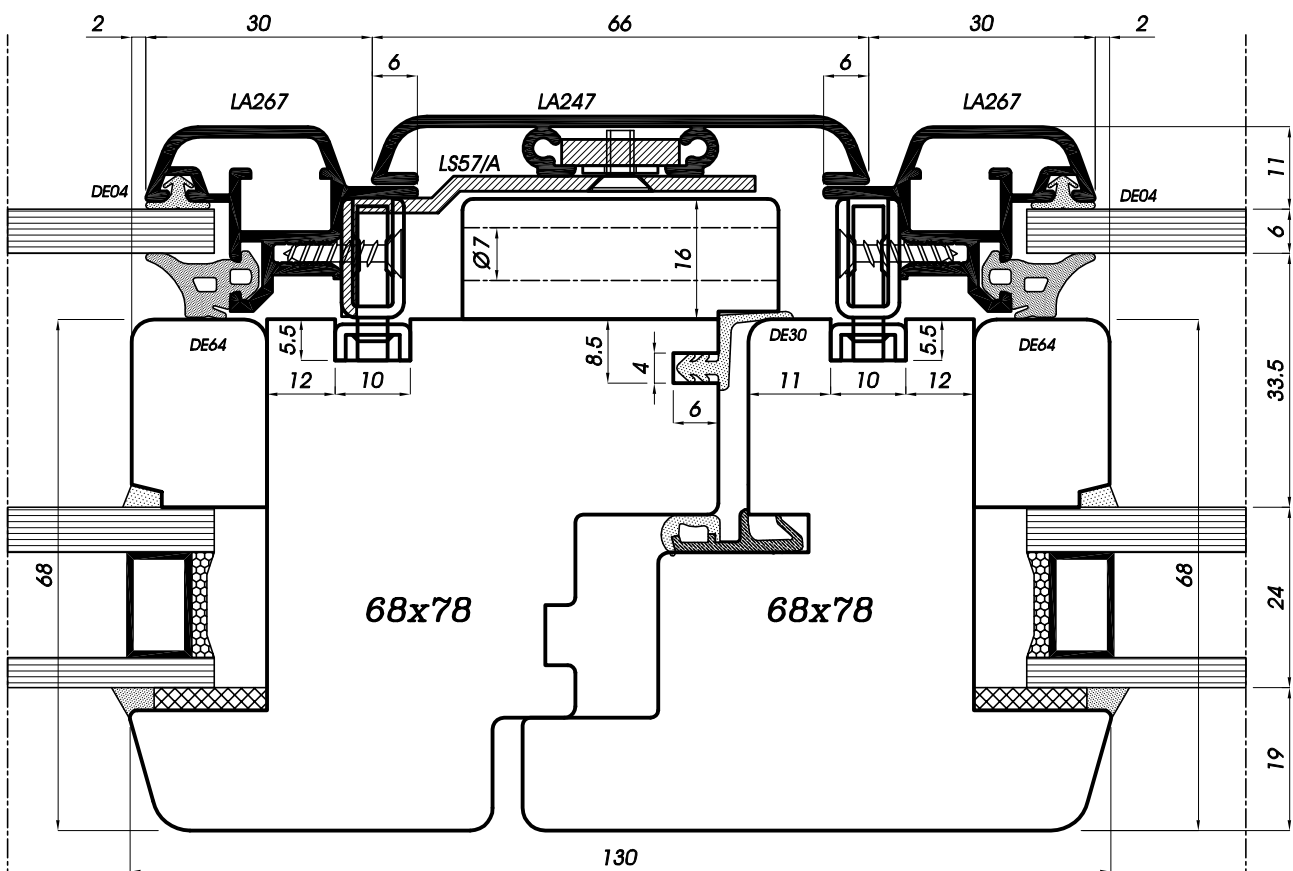
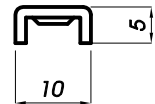
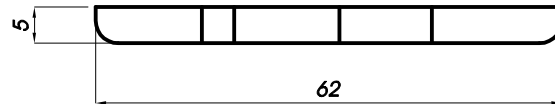

Squadretta LS57/A per fissaggio  
profilo LA247 sull'anta LA267  
Una ogni 300mm

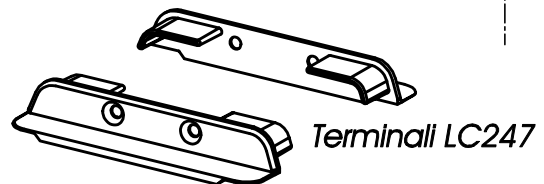

Terminali LC247

Sezione orizzontale chiusura centrale con profilo LA247  
 Horizontalschnitt Stulpprofil LA247  
 Sección horizontal del cierre central con perfil LA247  
 Coupe horizontal battement central avec profil LA247  
 Horizontal section of the middle clamp with profil LA247

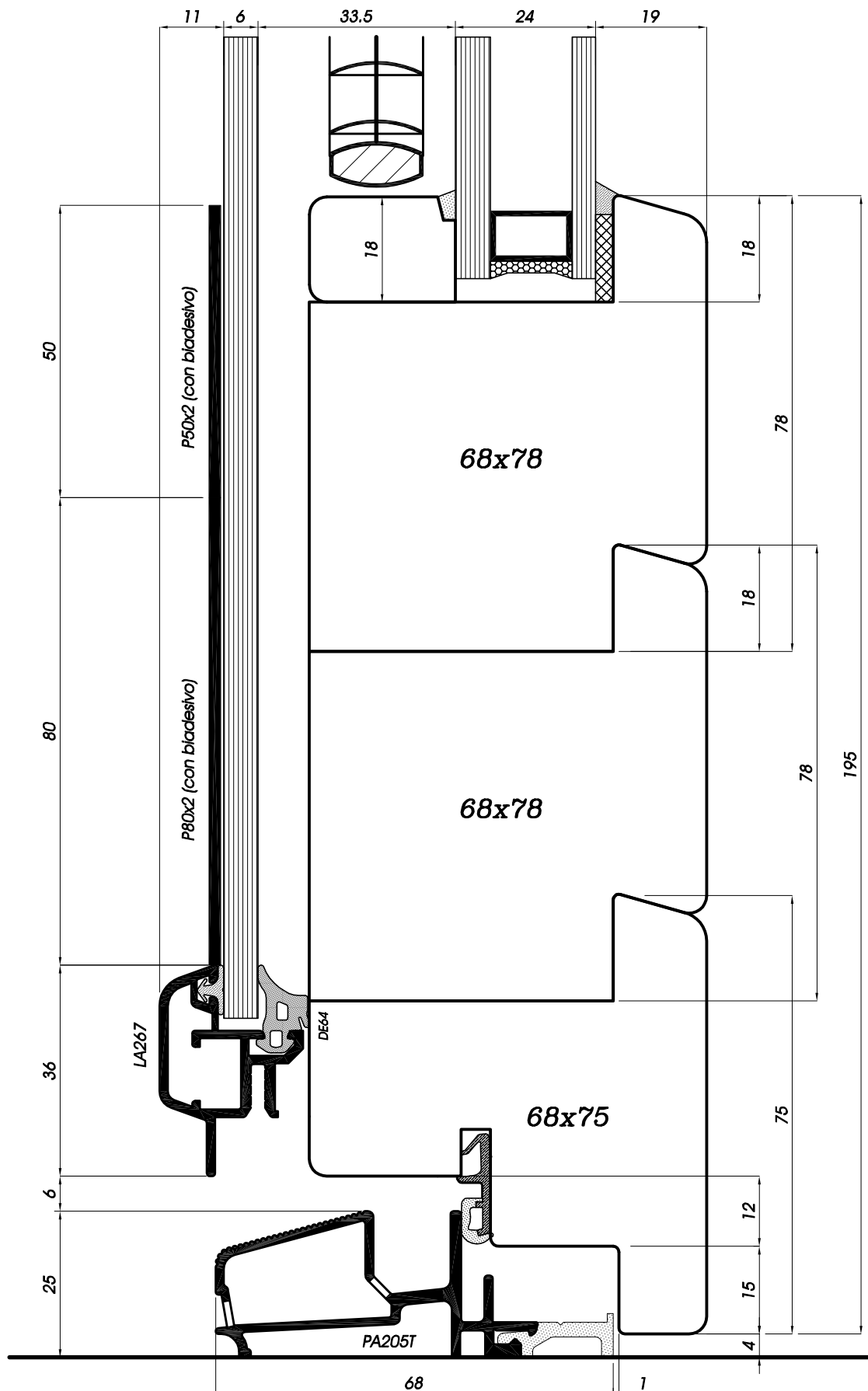

Sezione verticale traverso inferiore portafinestra con PA205T  
 Vertikalschnitt Balkontür quer unten mit PA205T  
 Sección vertical travesaño inferior puertaventana con PA205T  
 Coupe verticale traverse inférieure porte-fenêtre avec PA205T  
 Vertical section of the window-door's lower ledge

# Squadretta LS48/1

DA UTILIZZARE SOLO PER FINITURE IN ELETROCOLORE  
OSSIDATO E DECORATO LEGNO

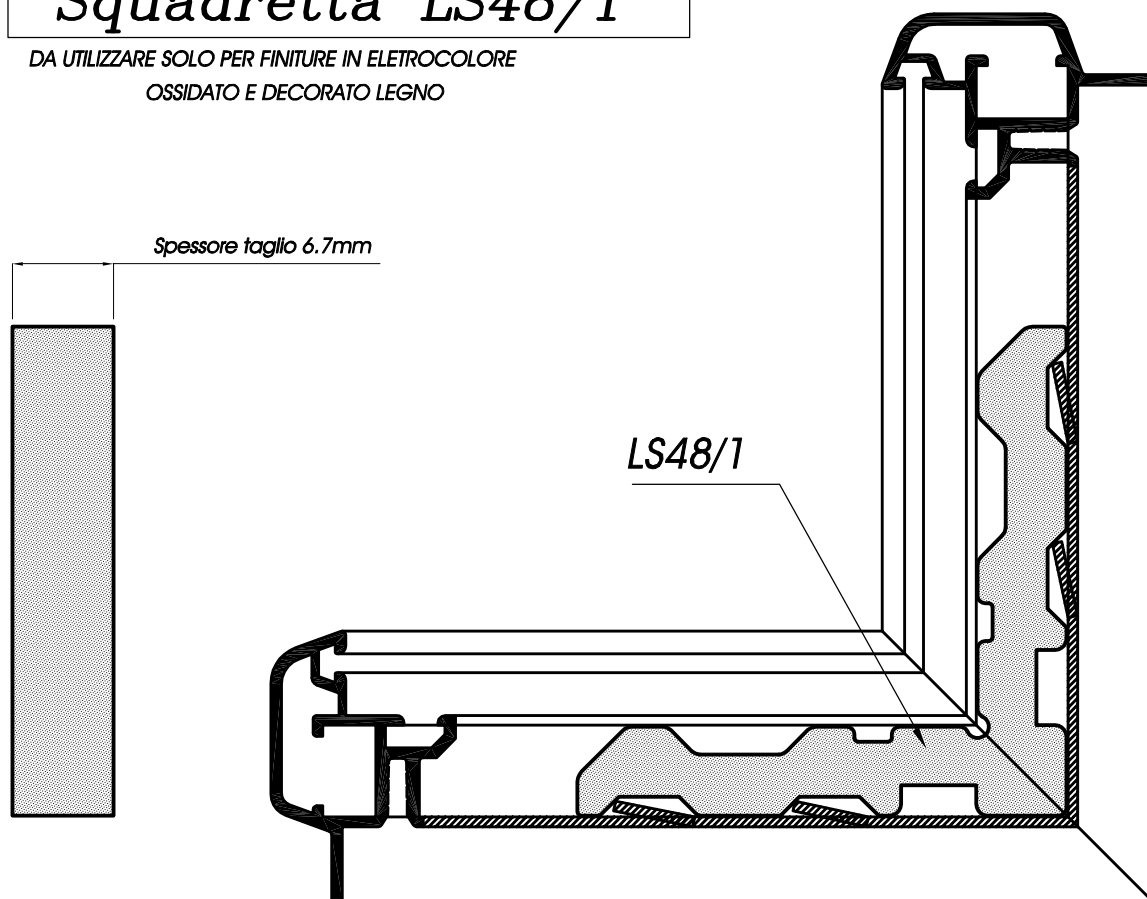

*Sistema Verbund  
Soft-Line/45*

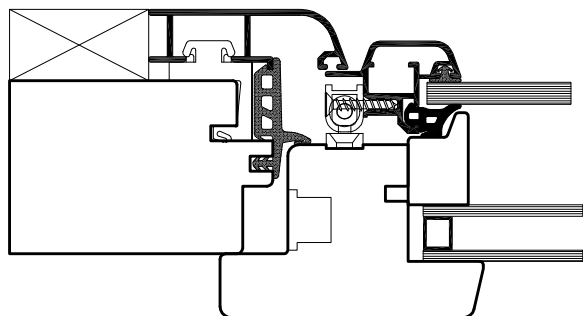

*Sistema Verbund  
Soft-Line sp.68mm*

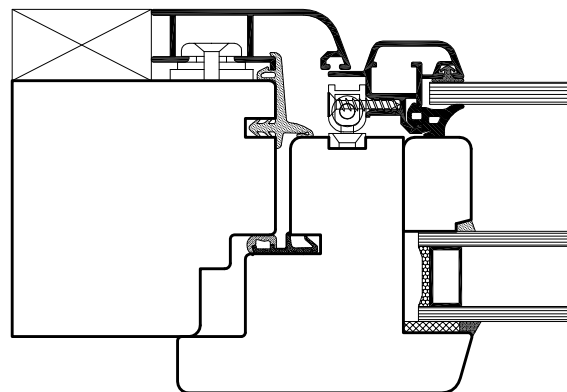

*Giunzione meccanica del profilo LA267  
Mechanische Verbindung Profil LA267  
Acoplamiento mecánico del perfil LA267  
Assemblage mécanique du profil LA267  
Mechanical connection of the profile LA267*

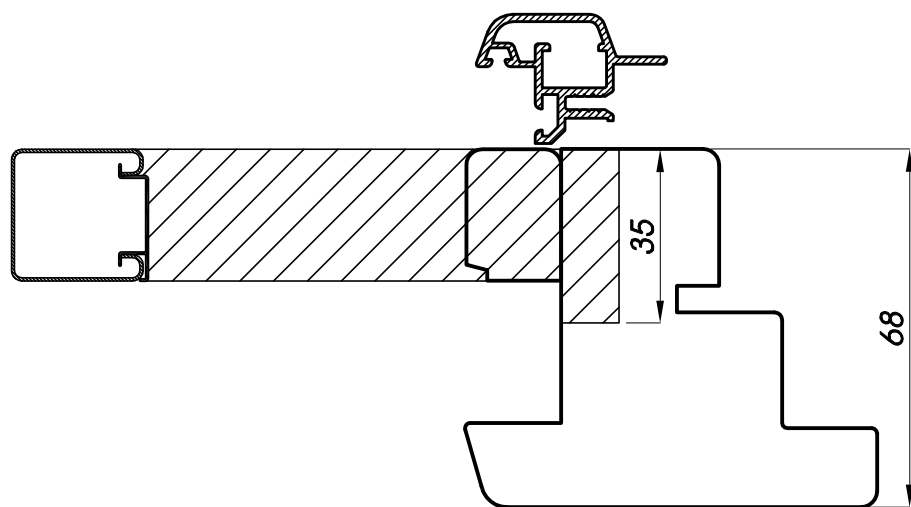
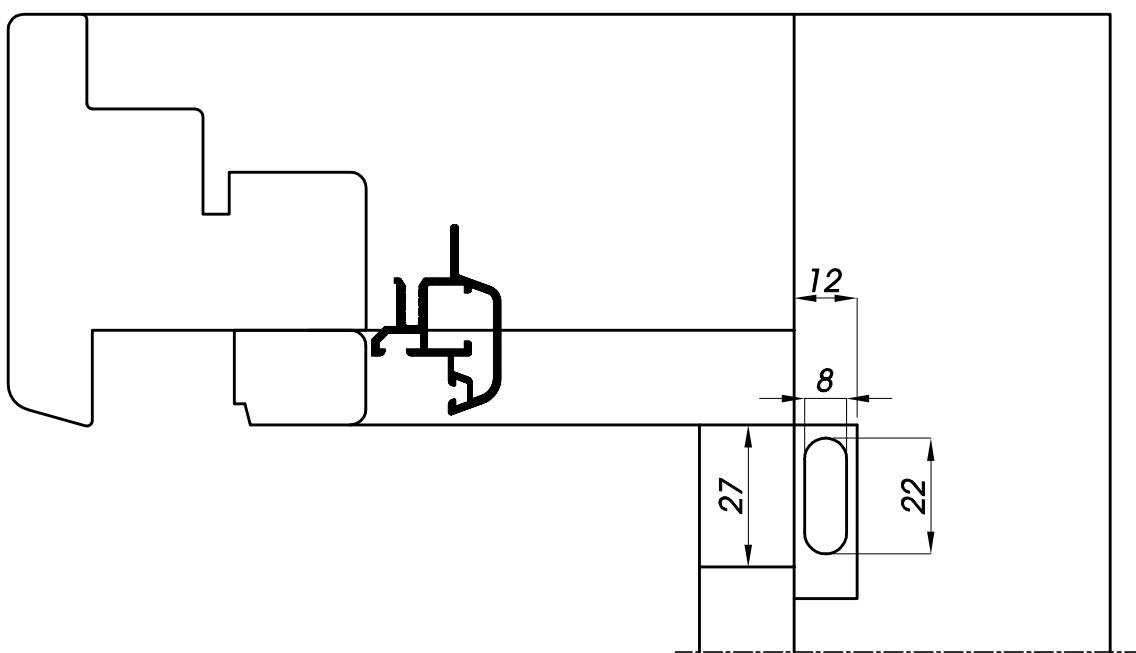
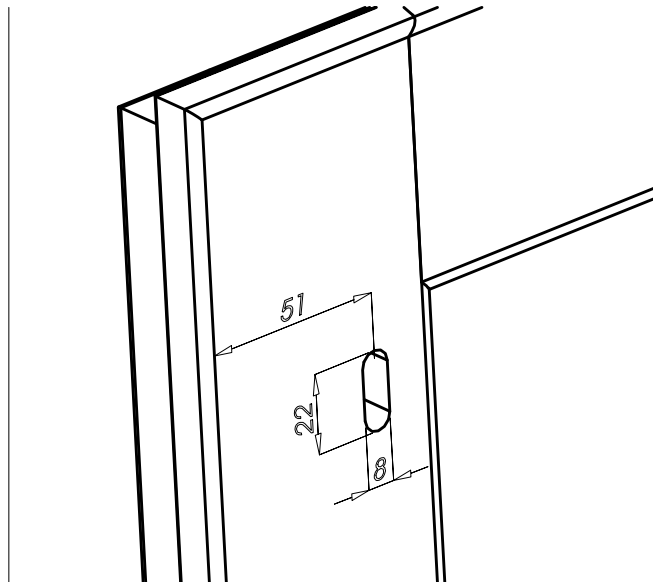
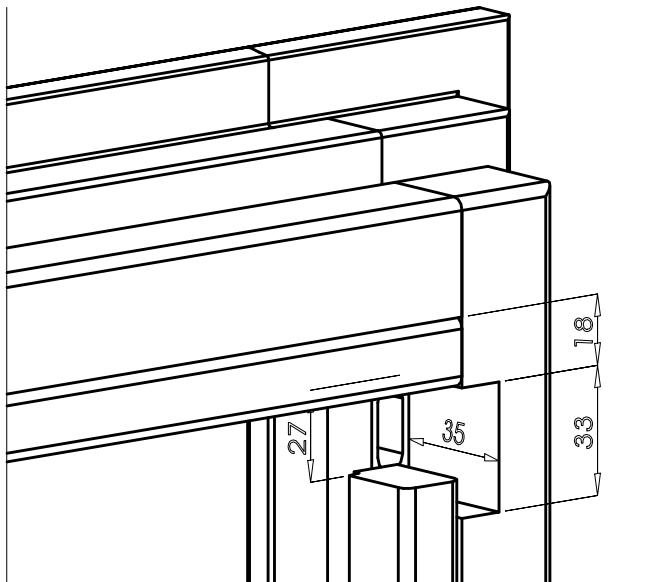

*Lavorazioni per inserimento tendina*  
*Verarbeitung zum Einfügen der Jalousie*  
*Operaciones para insertar la cortina*  
*Usinage pour insertion store à lamelles*  
*Working for the window-shade's insertion*

*Sistema*

*Soft-Line/S*

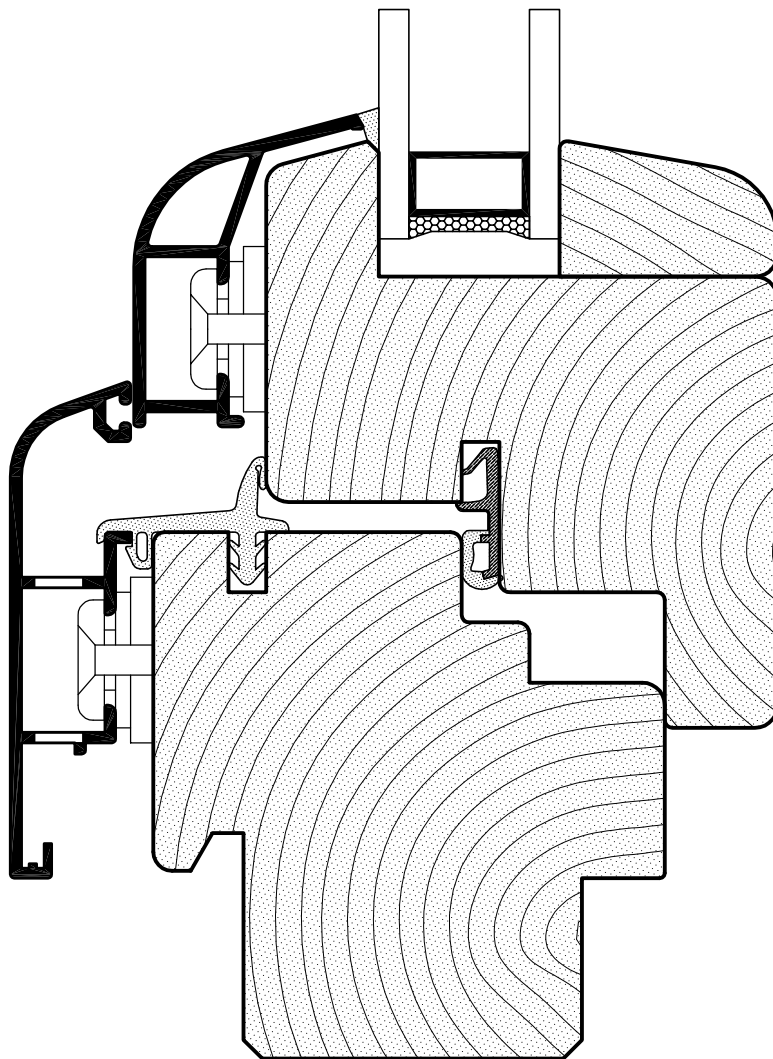

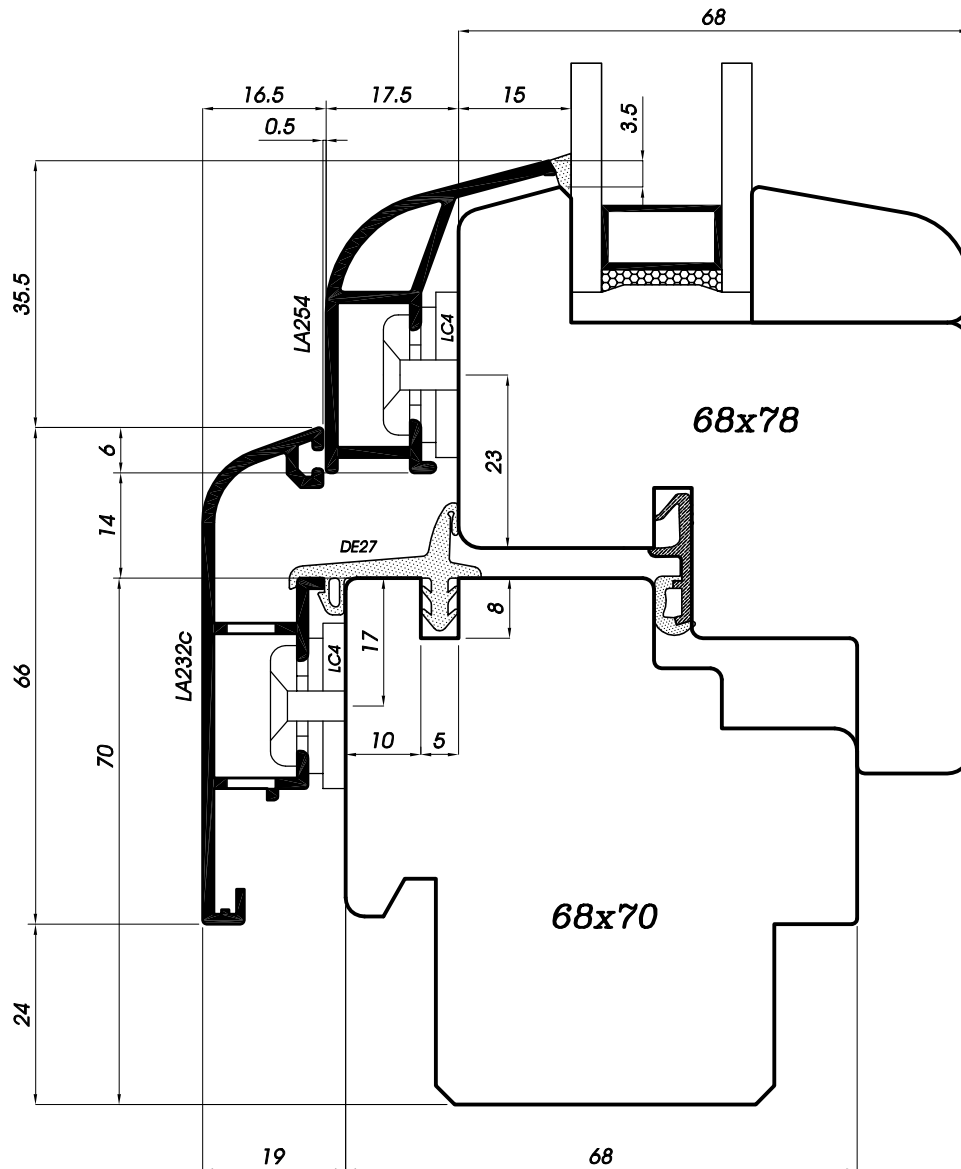
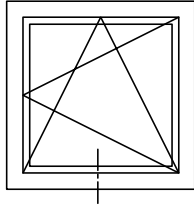

**Sezione verticale traverso inferiore finestra**  
**Vertikalschnitt Fenster quer unten**  
**Sección vertical travesaño inferior de la ventana**  
**Coupe verticale traverse inférieure fenêtre**  
**Vertical section of the window's lower ledge**

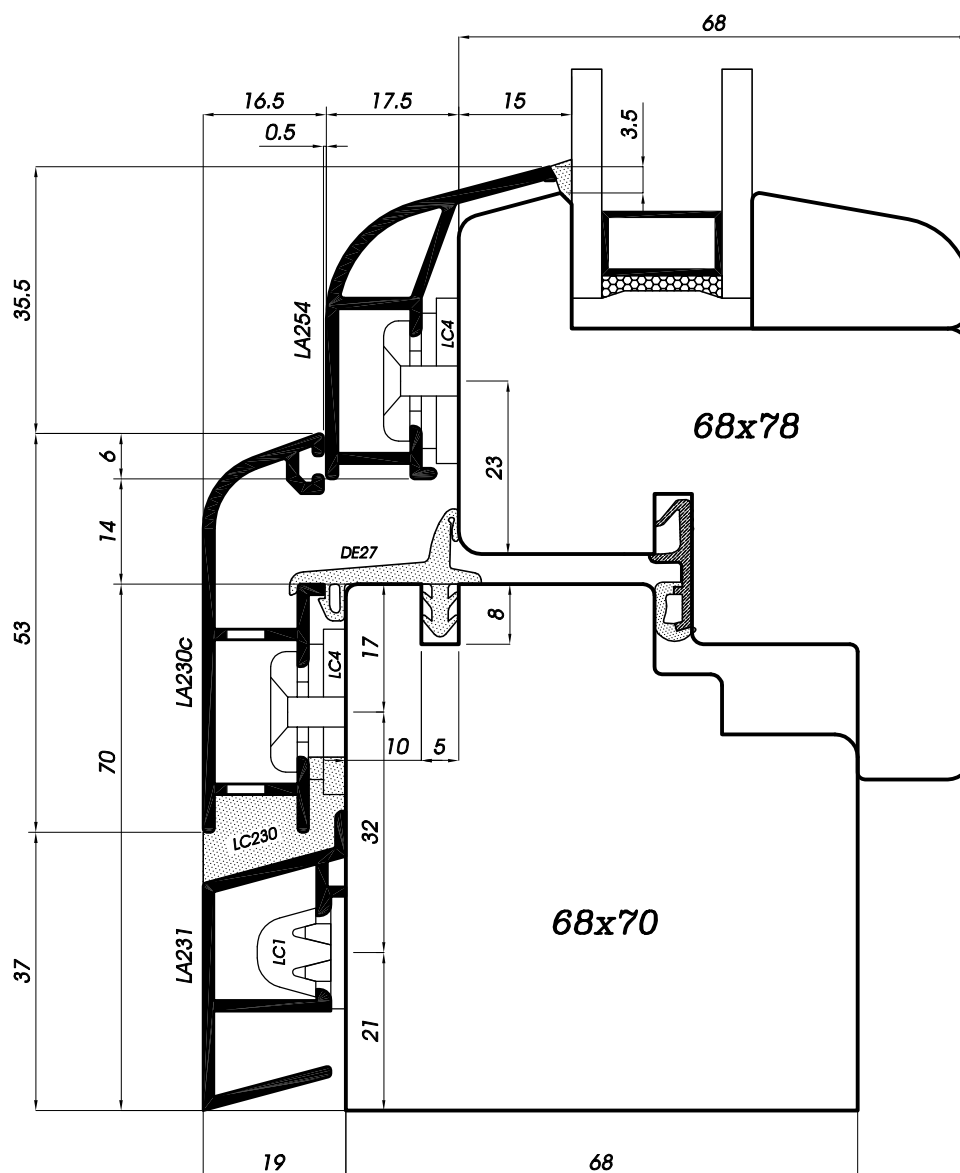
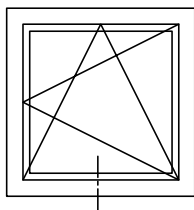

**Sezione verticale traverso inferiore finestra**  
**Vertikalschnitt Fenster quer unten**  
**Sección vertical travesaño inferior de la ventana**  
**Coupe verticale traverse inférieure fenêtre**  
**Vertical section of the window's lower ledge**



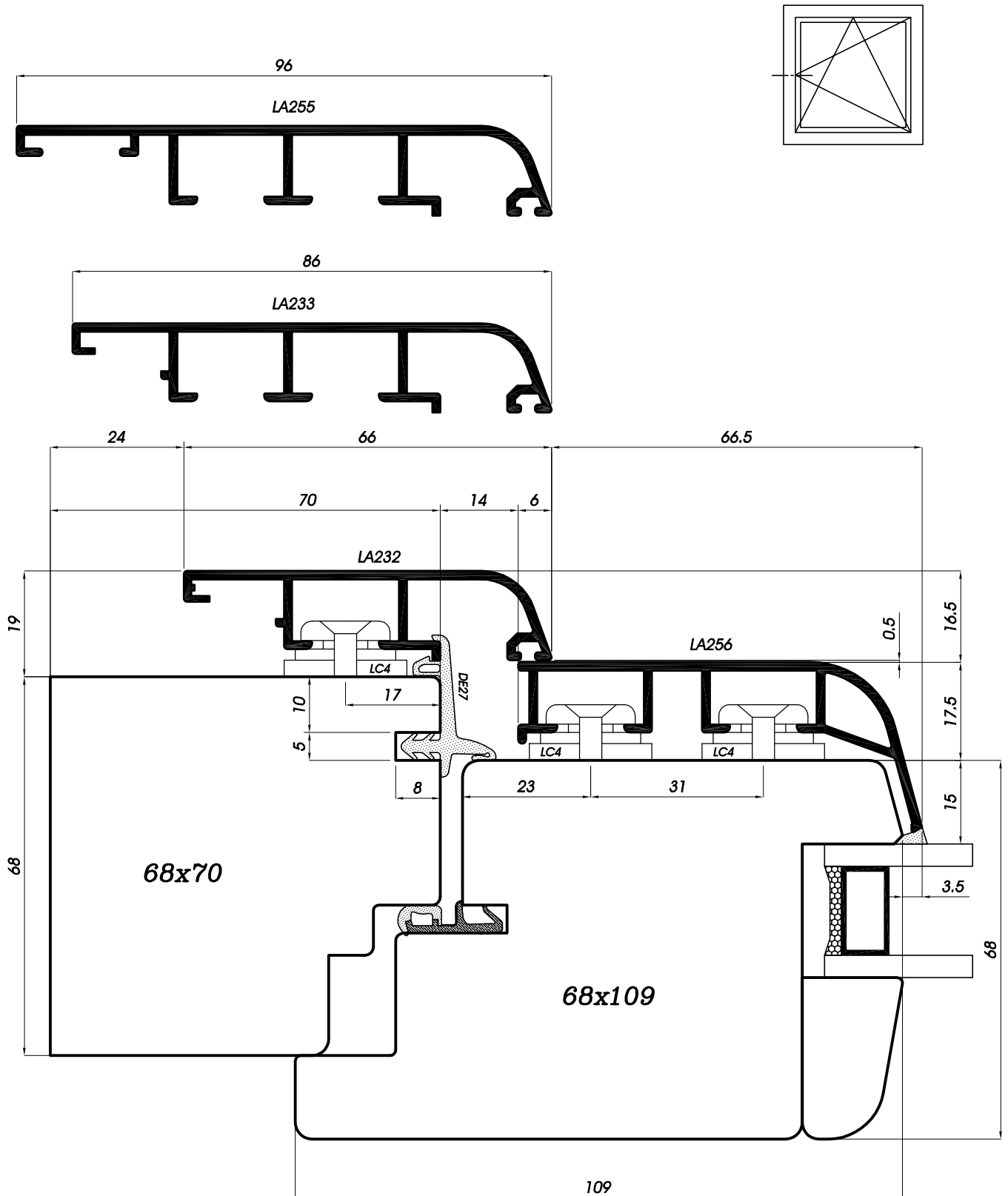

Sezione orizzontale montanti laterali  
 Horizontalschnitt senkrecht seitlich  
 Sección horizontal de montantes laterales  
 Coupe horizontale montants latéraux  
 Horizontal section of the lateral jambs

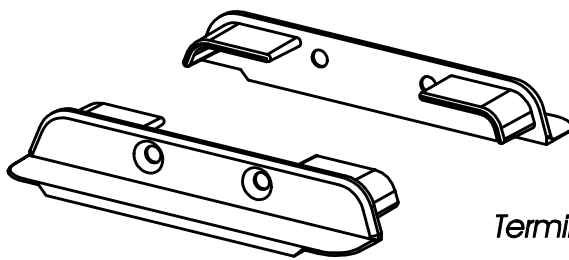
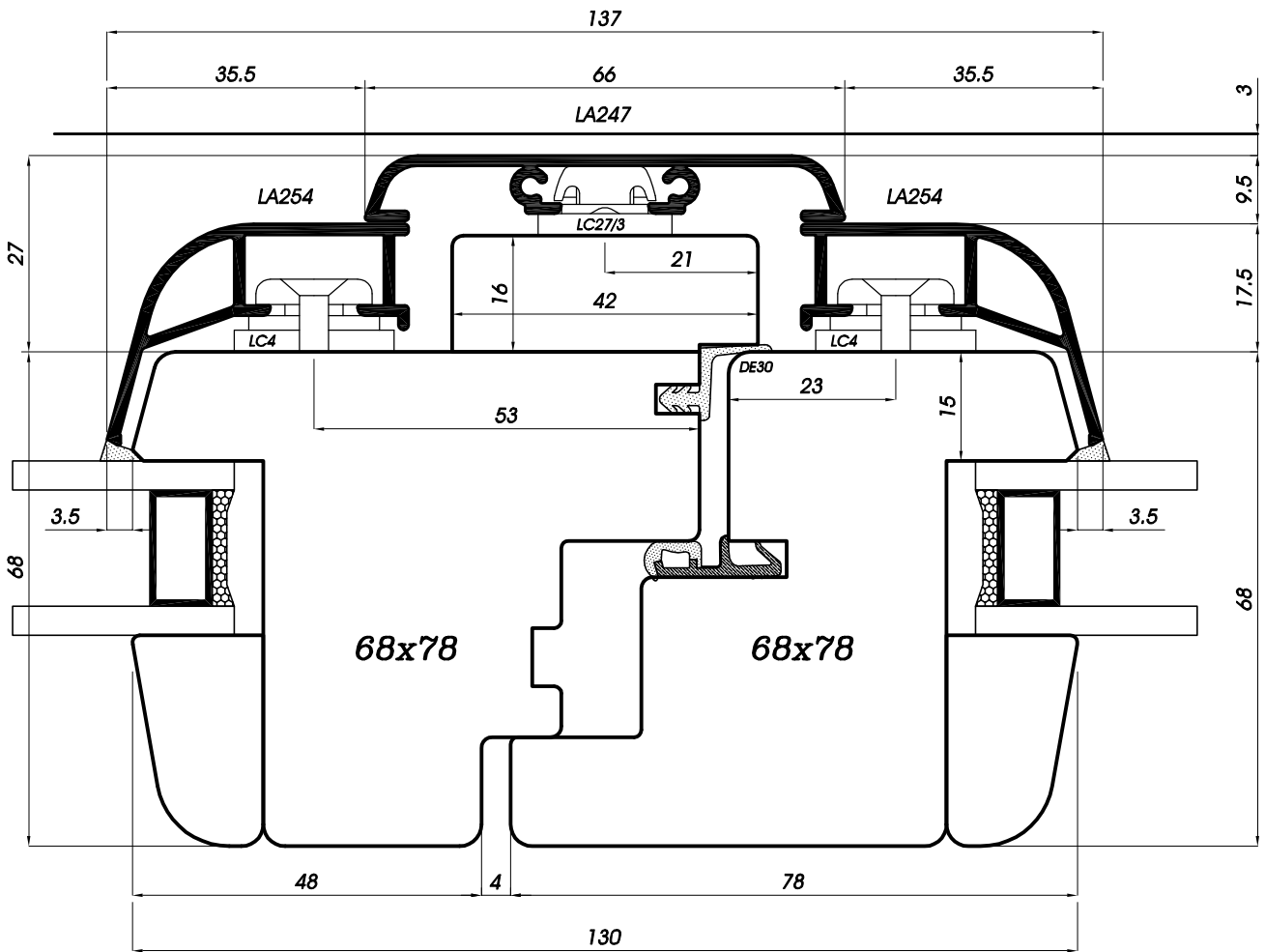
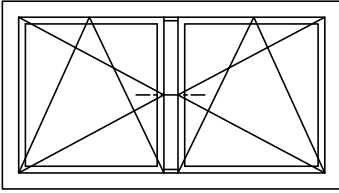

Terminali LC247

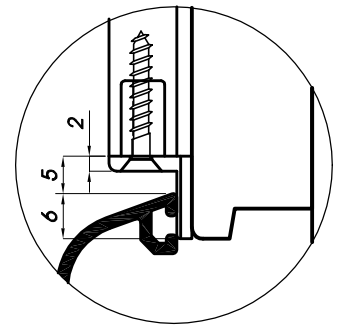

Sezione orizzontale chiusura centrale con profilo LA247  
 Horizontalschnitt Stulpprofil LA247  
 Sección horizontal del cierre central con perfil LA247  
 Coupe horizontale battement central avec profil LA247  
 Horizontal section of the middle clamp with profile LA 247

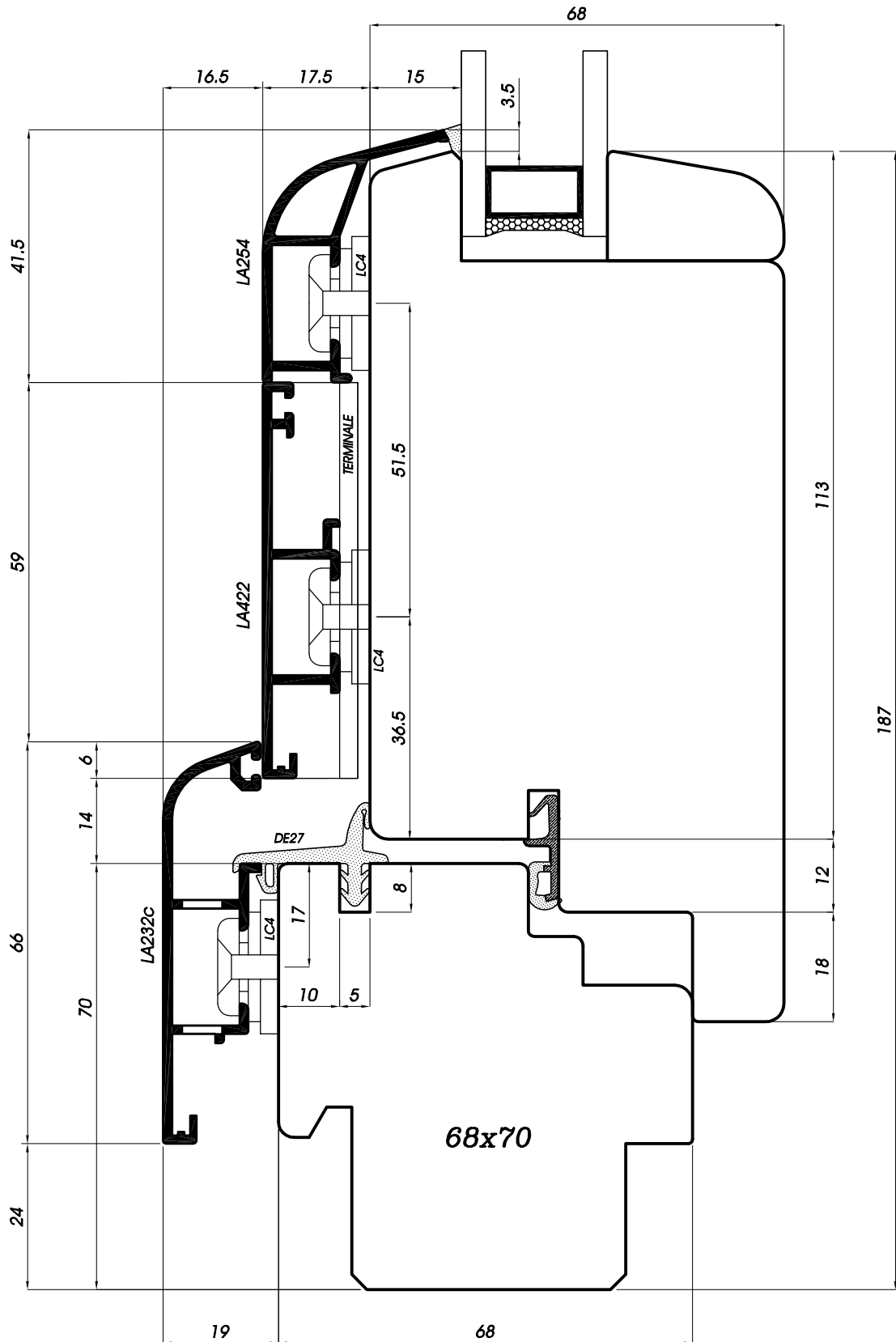

Sezione verticale traverso inferiore portafinestra  
 Vertikalschnitt Balkontür quer unten  
 Sección vertical travesaño inferior puertaventana  
 Coupe verticale traverse inférieure porte-fenêtre  
 Vertical section of the window-door's lower ledger

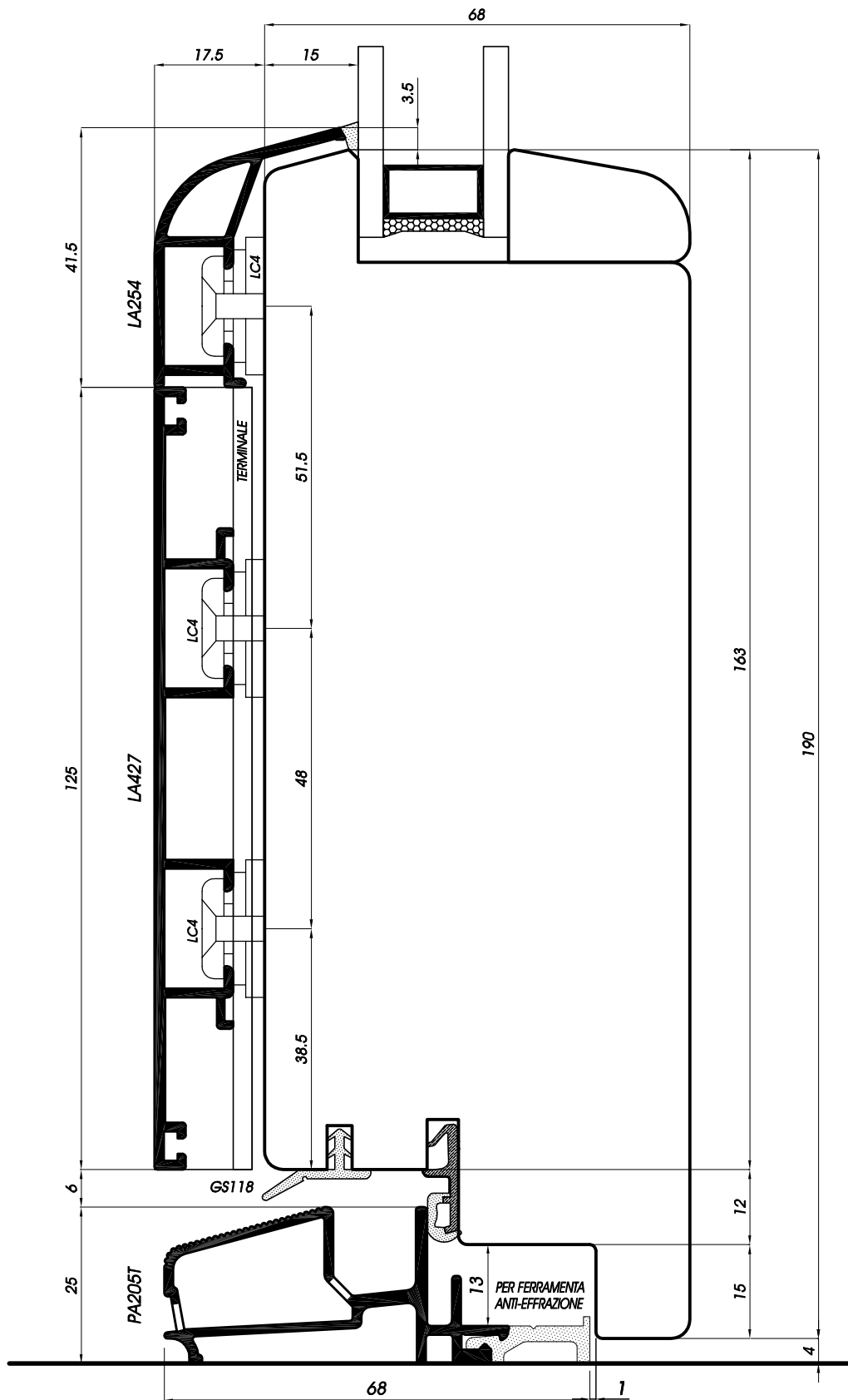

Sezione verticale traverso inferiore portafinestra con PA205T  
 Vertikalschnitt Balkontür quer unten mit PA205T  
 Sección vertical travesaño inferior puertaventana con PA205T  
 Coupe verticale traverse inférieure porte-fenêtre avec PA205T  
 Vertical section of the window-door's lower ledger with PA205T

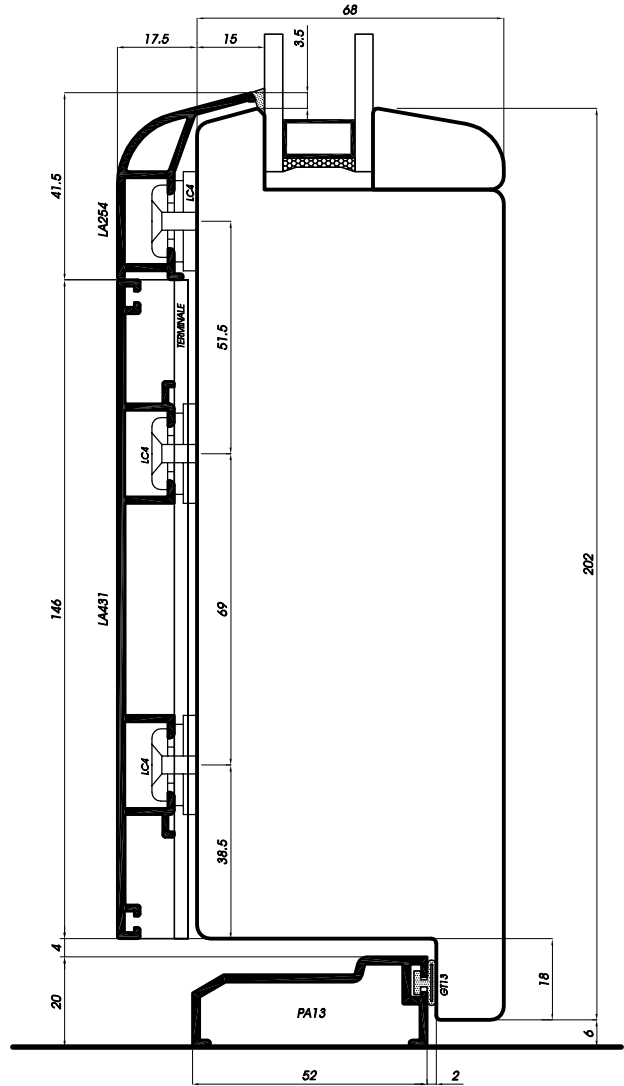
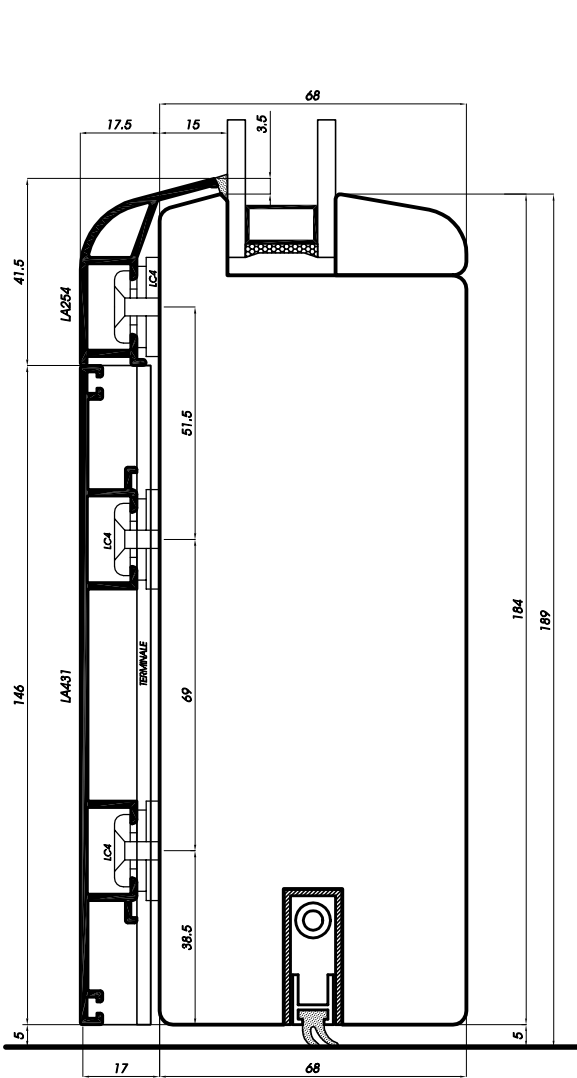

Sezione verticale traverso inferiore portafinestra  
 Vertikalschnitt Balkontür quer unten  
 Sección vertical travesaño inferior puertaventana  
 Coupe verticale traverse inférieure porte-fenêtre  
 Vertical section of the window-door's lower ledger

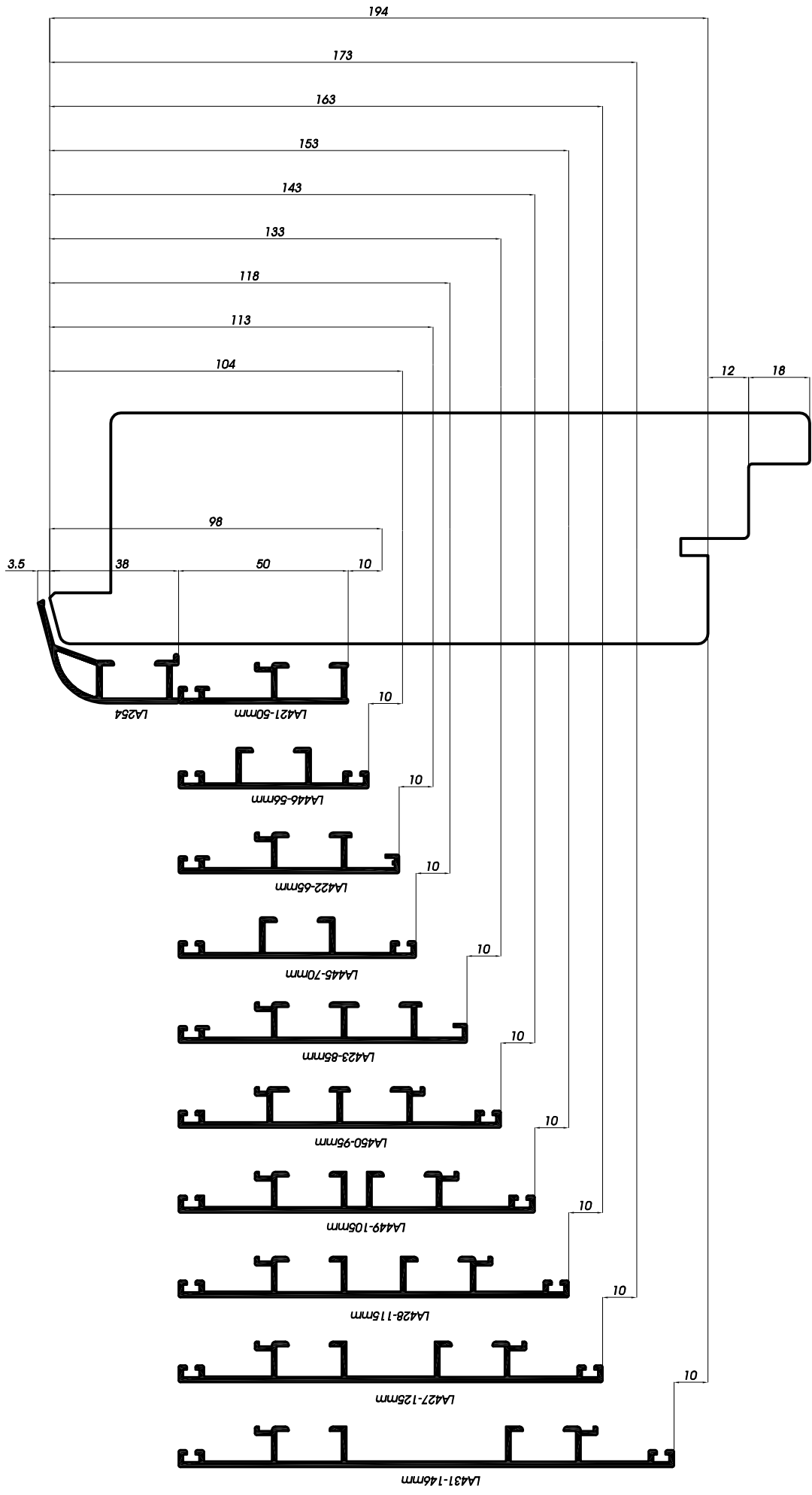

Misure disponibili su traverso inferiore portafinestra  
 Mögliche Sockelhöhen bei Balkontüren  
 Medidas disponibles para el travesaño inferior puertaventana  
 Différentes mesures possibles pour l'empilage sur porte-fenêtre  
 Possible measures over the window-door's lower ledger

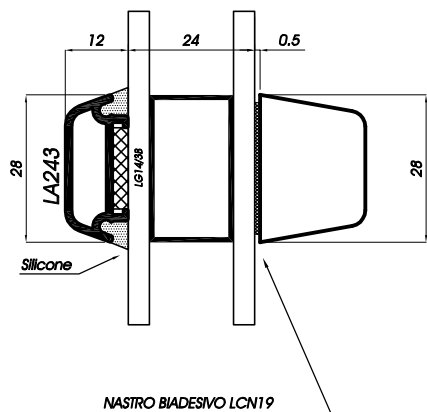
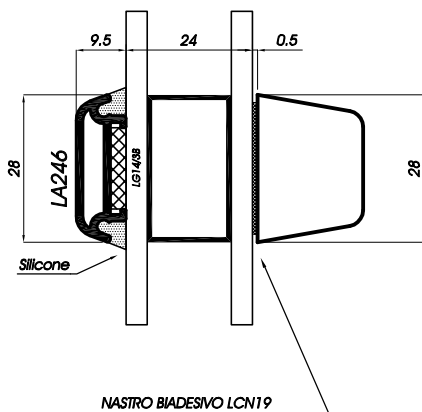
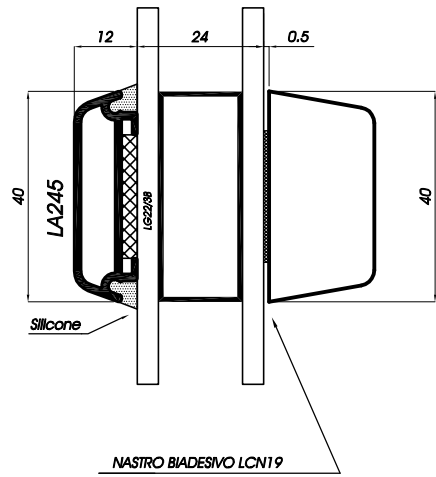
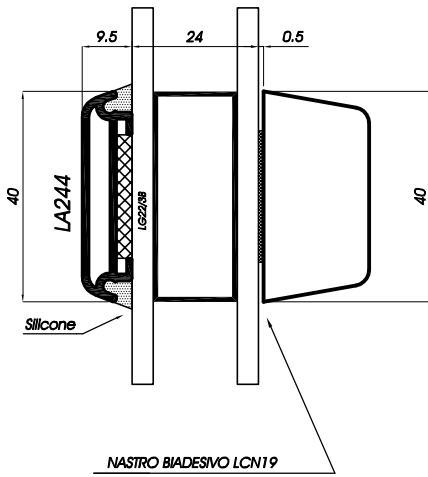
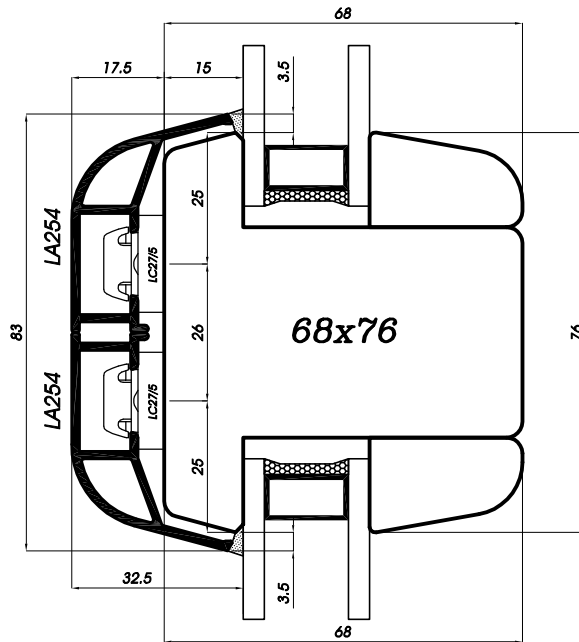

**Sezione verticale traversi intermedi anta**  
**Vertikalschnitt der Sprossen im Flügel**  
**Sección vertical travesaños intermedios de la hoja**  
**Coupe verticale des traverses intermédiaires du vantail**  
**Vertical section of the wing's middle ledgers**

*Sistema*

*SOFT-Line Plus*

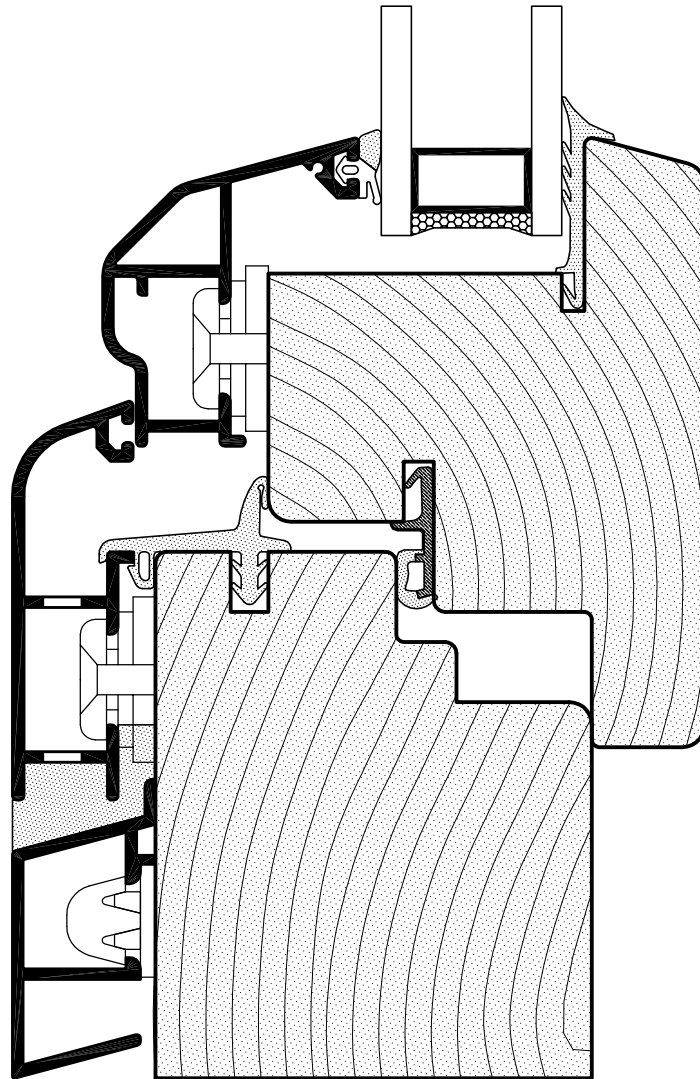



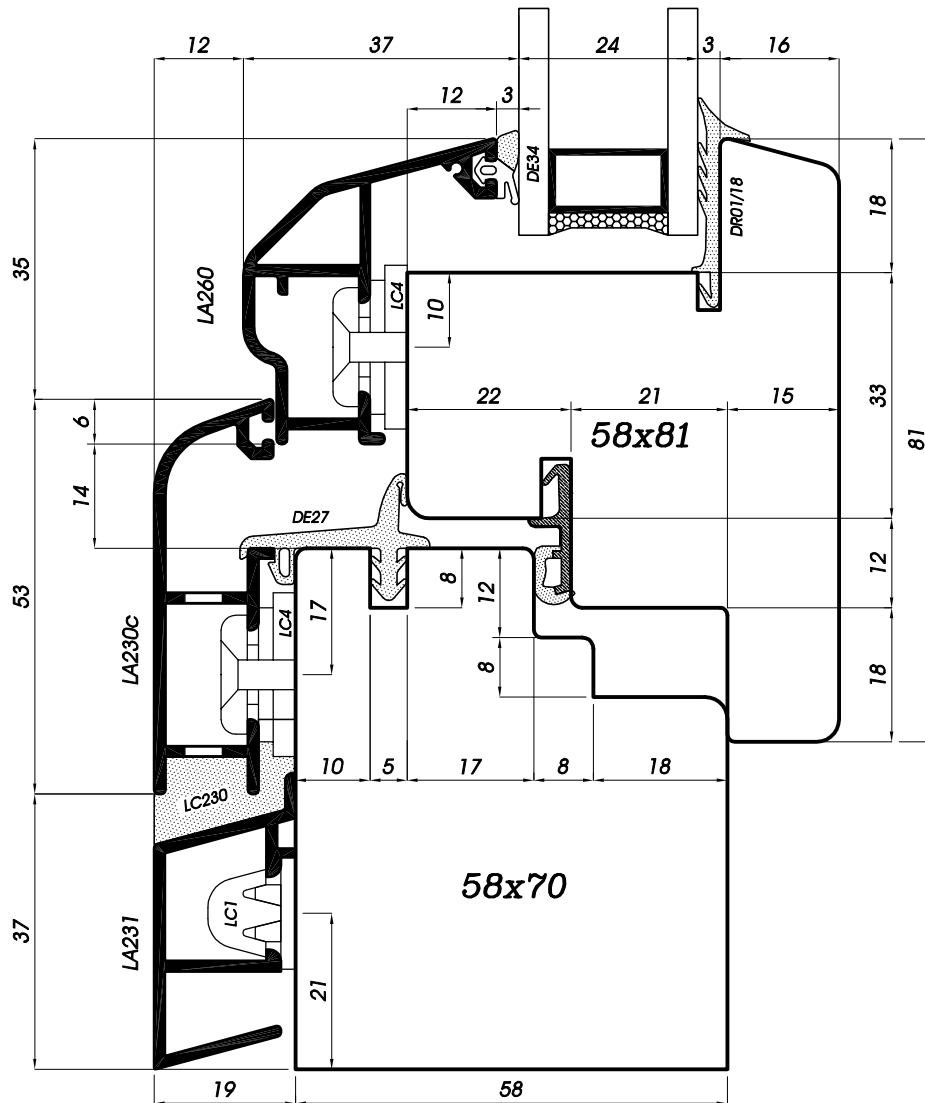
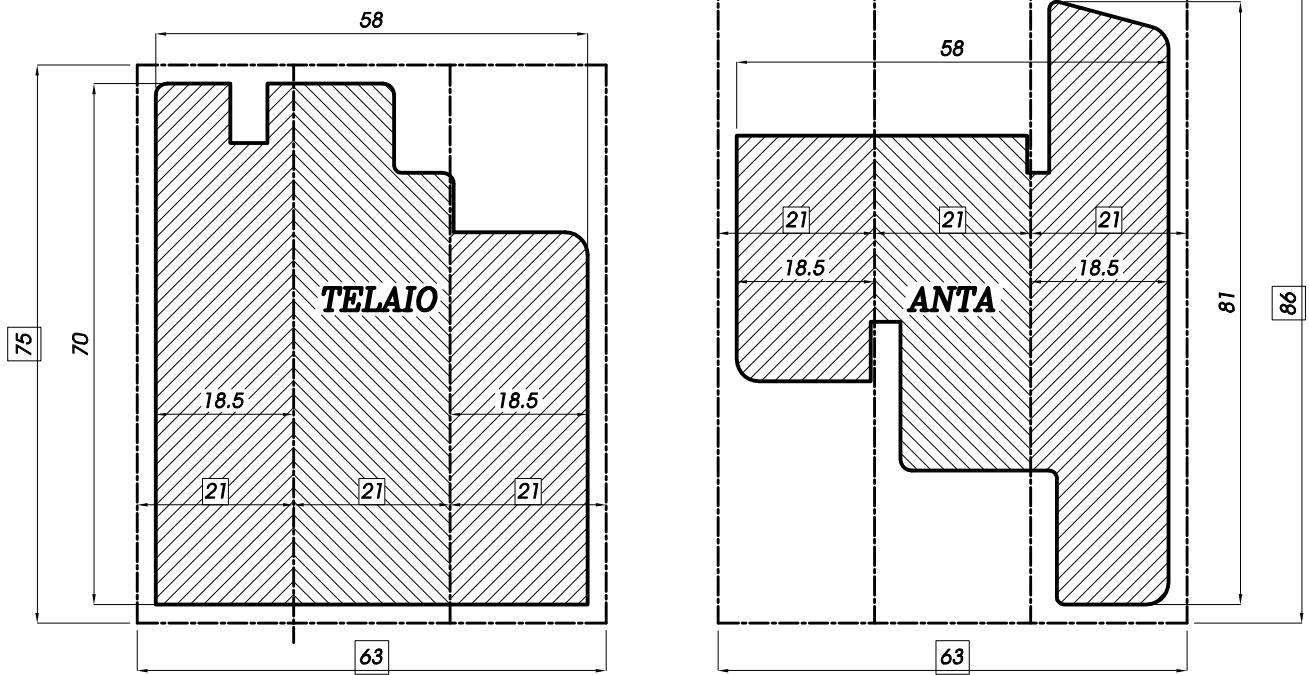

Sezione verticale traverso inferiore finestra  
 Vertikalschnitt Fenster quer unten  
 Sección vertical travesaño inferior de la ventana  
 Coupe verticale traverse inférieure fenêtré  
 Vertical section of the window's lower ledger

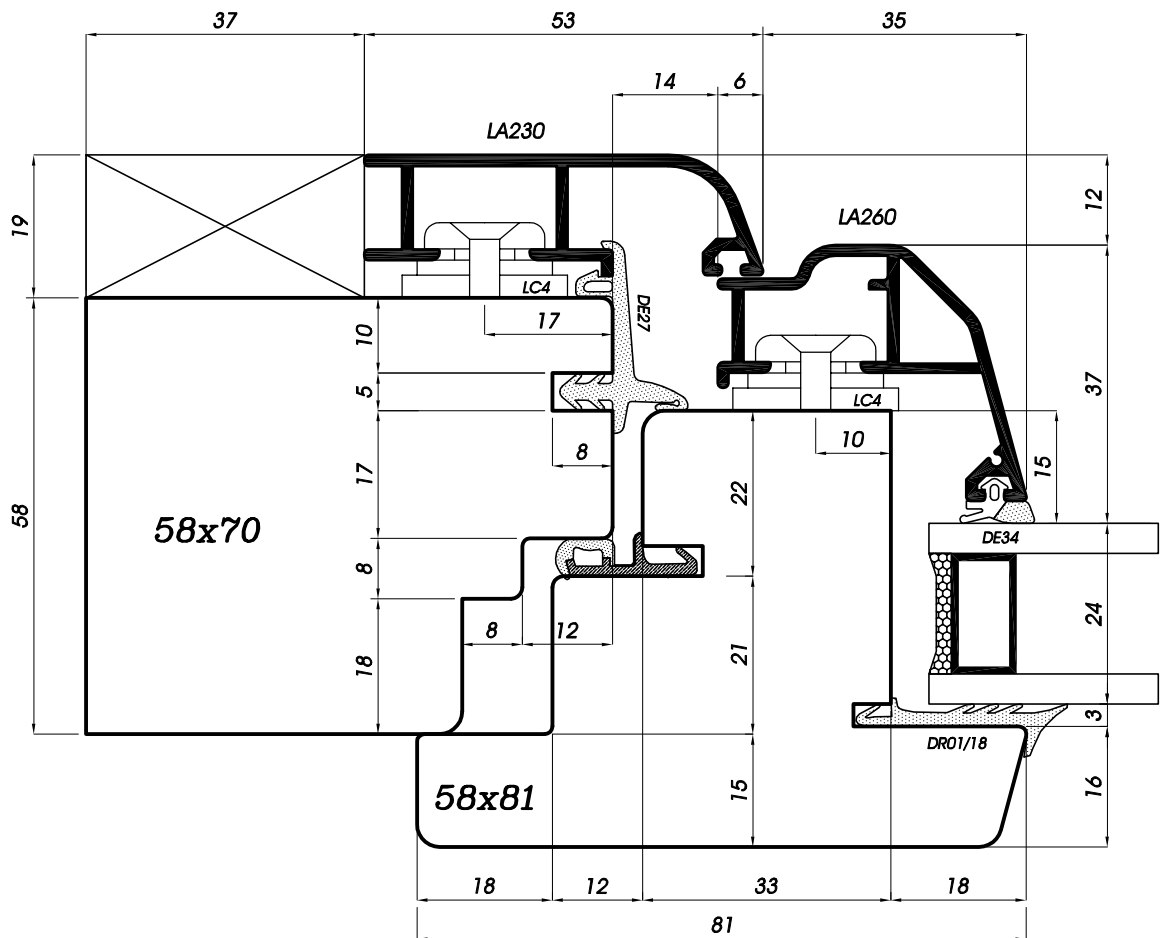
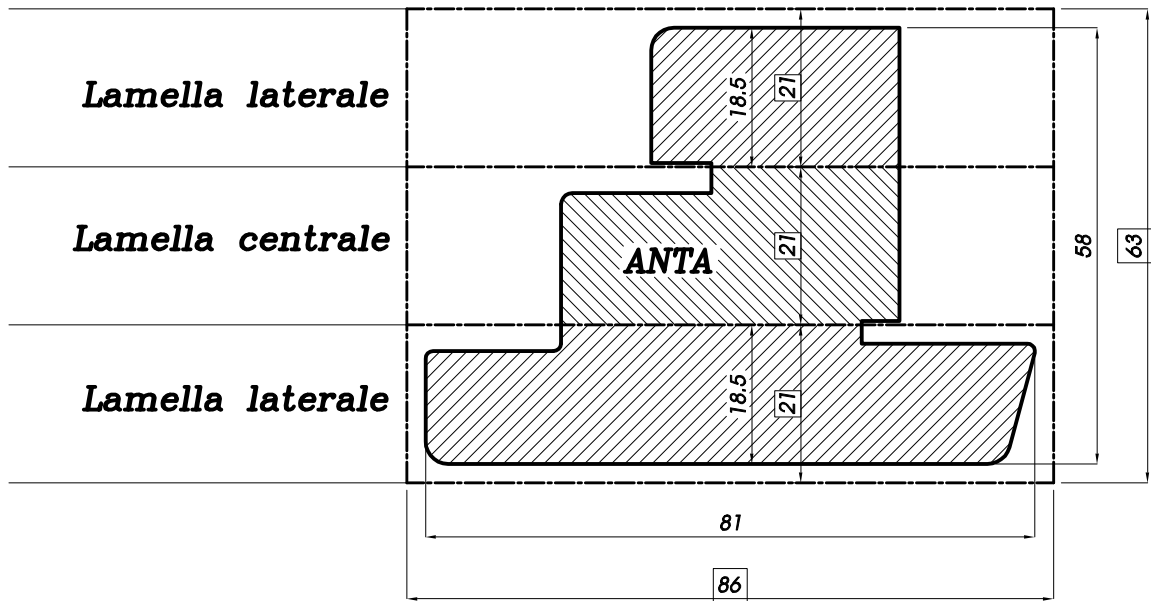

Sezione orizzontale montante laterale  
 Horizontalschnitt senkrecht seitlich  
 Sección horizontal montante lateral  
 Coupe horizontale du montant latéral  
 Horizontal section of the lateral jamb

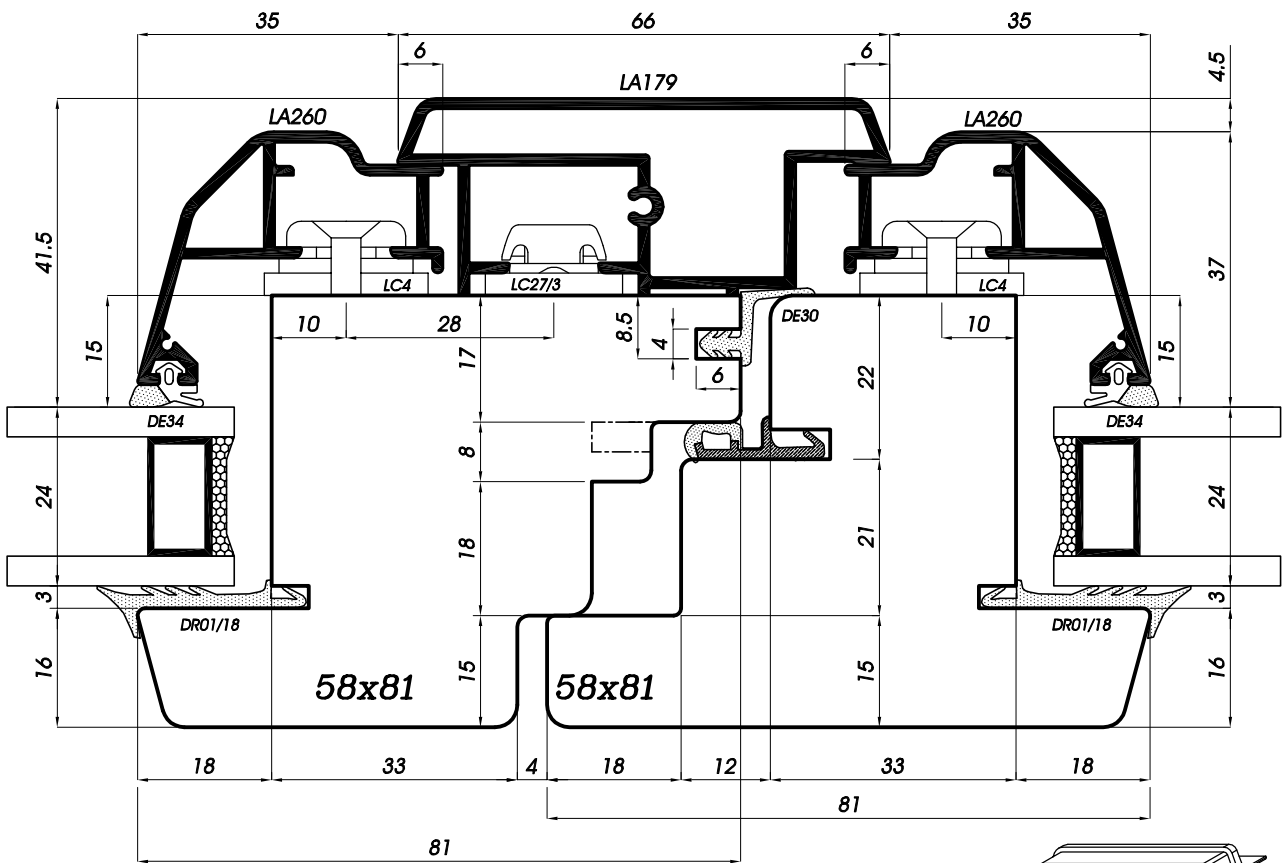
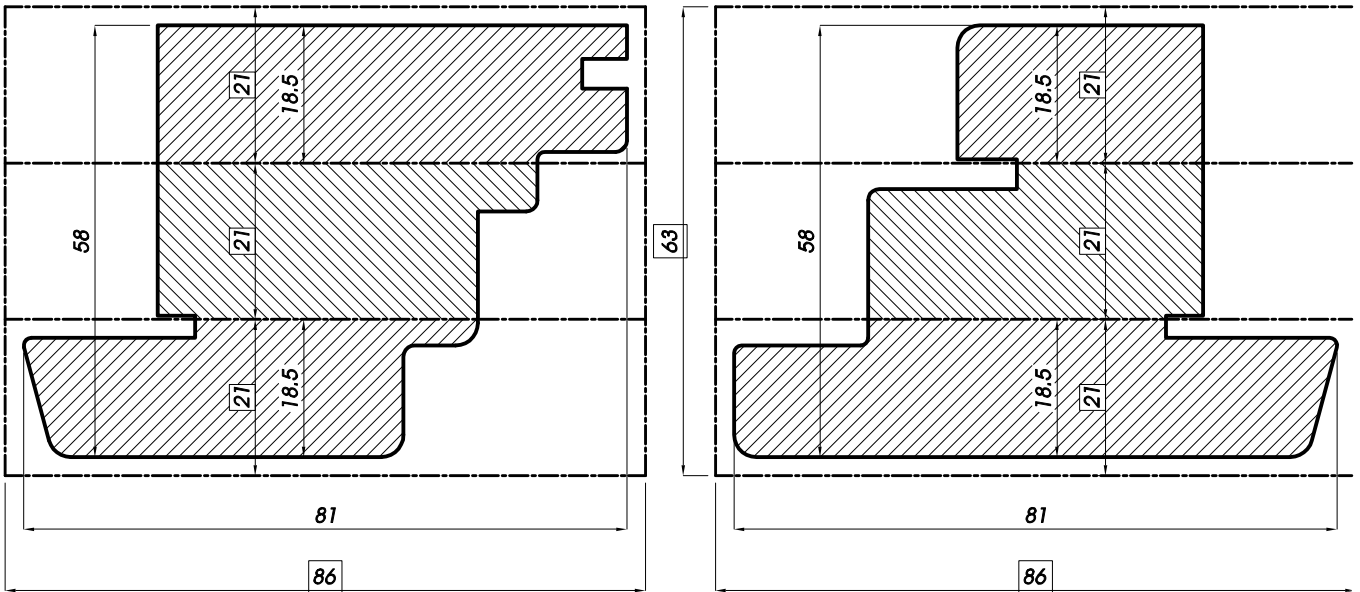

Terminali  
LC179 Dx-Sx

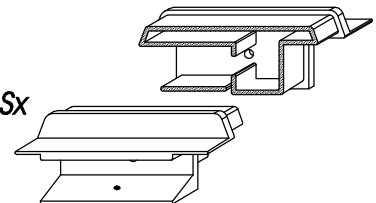

Sezione orizzontale chiusura centrale con profilo LA179  
 Horizontalschnitt Stulpprofil LA179  
 Sección horizontal del cierre central con perfil LA179  
 Coupe horizontale battement central avec profil LA179  
 Horizontal section of the middle clamp with profil LA 179

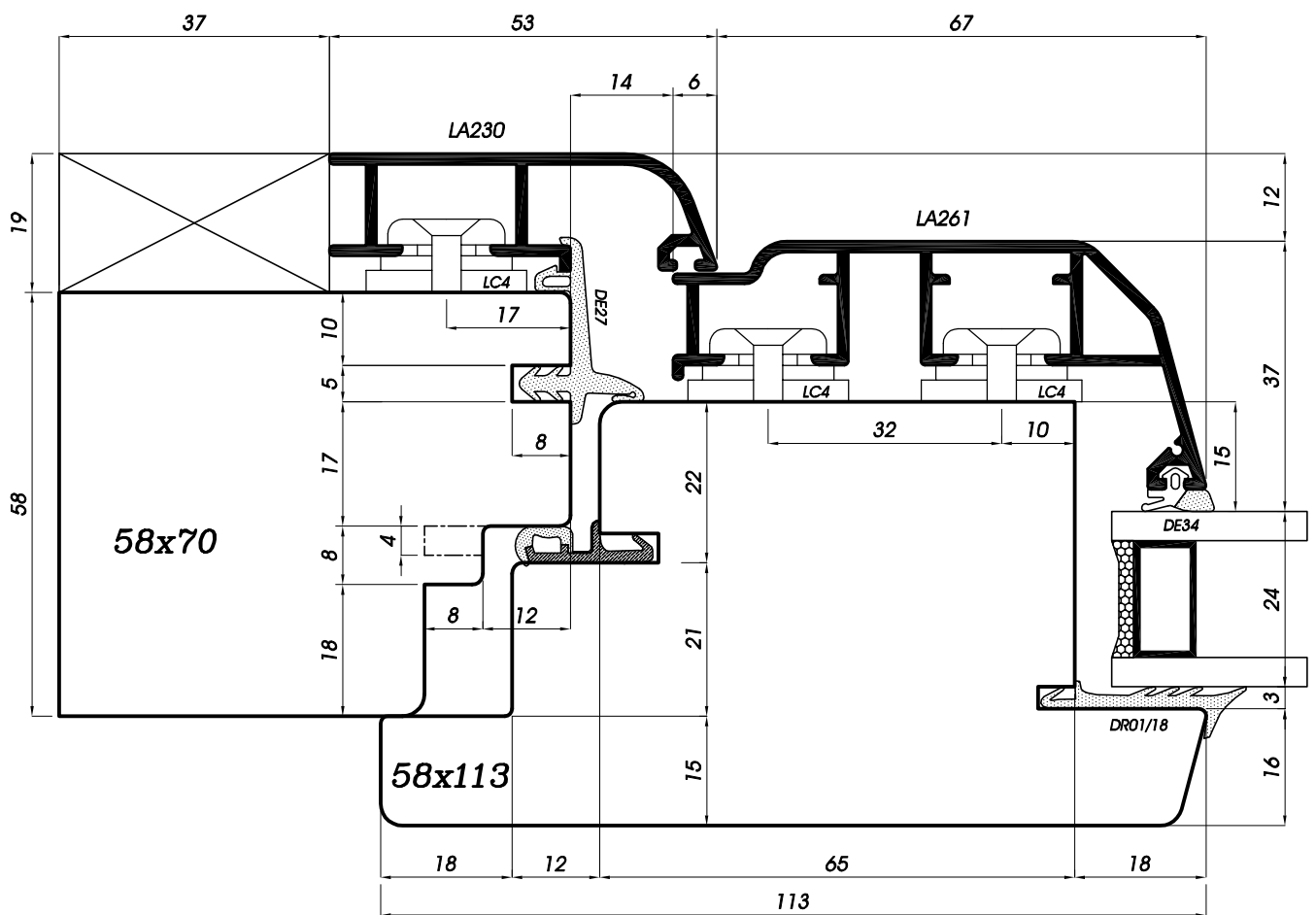
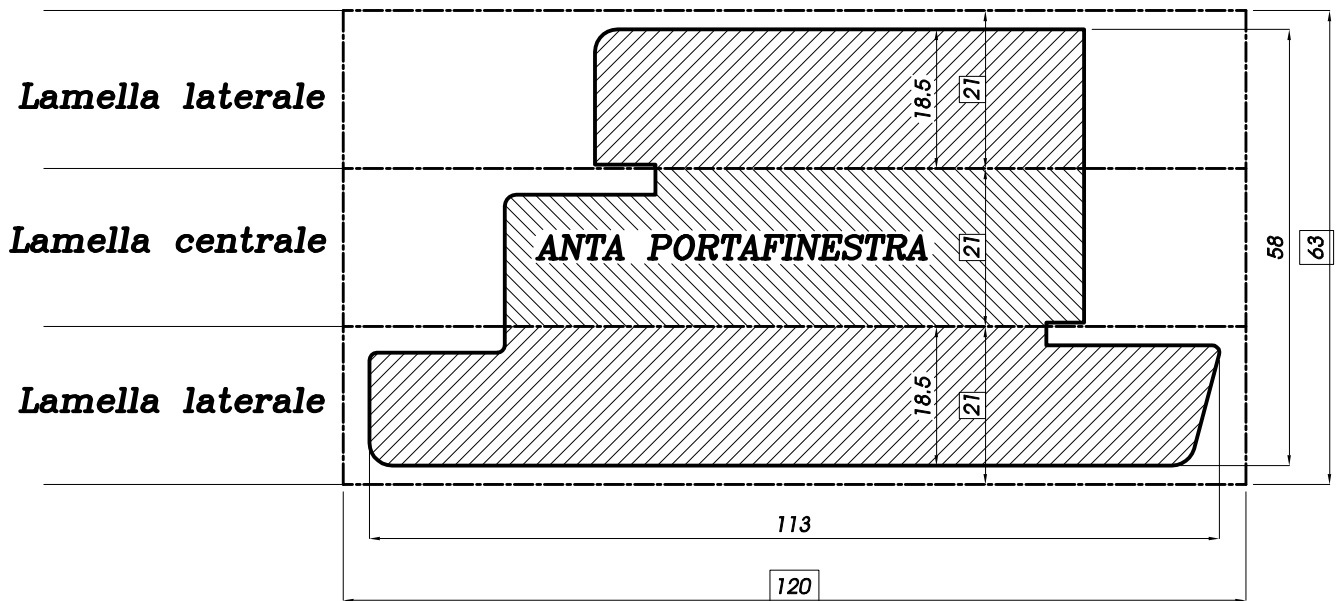

Sezione orizzontale montante laterale  
 Horizontalschnitt senkrecht seitlich  
 Sección horizontal montante lateral  
 Coupe horizontale du montant latéral  
 Horizontal section of the lateral jamb

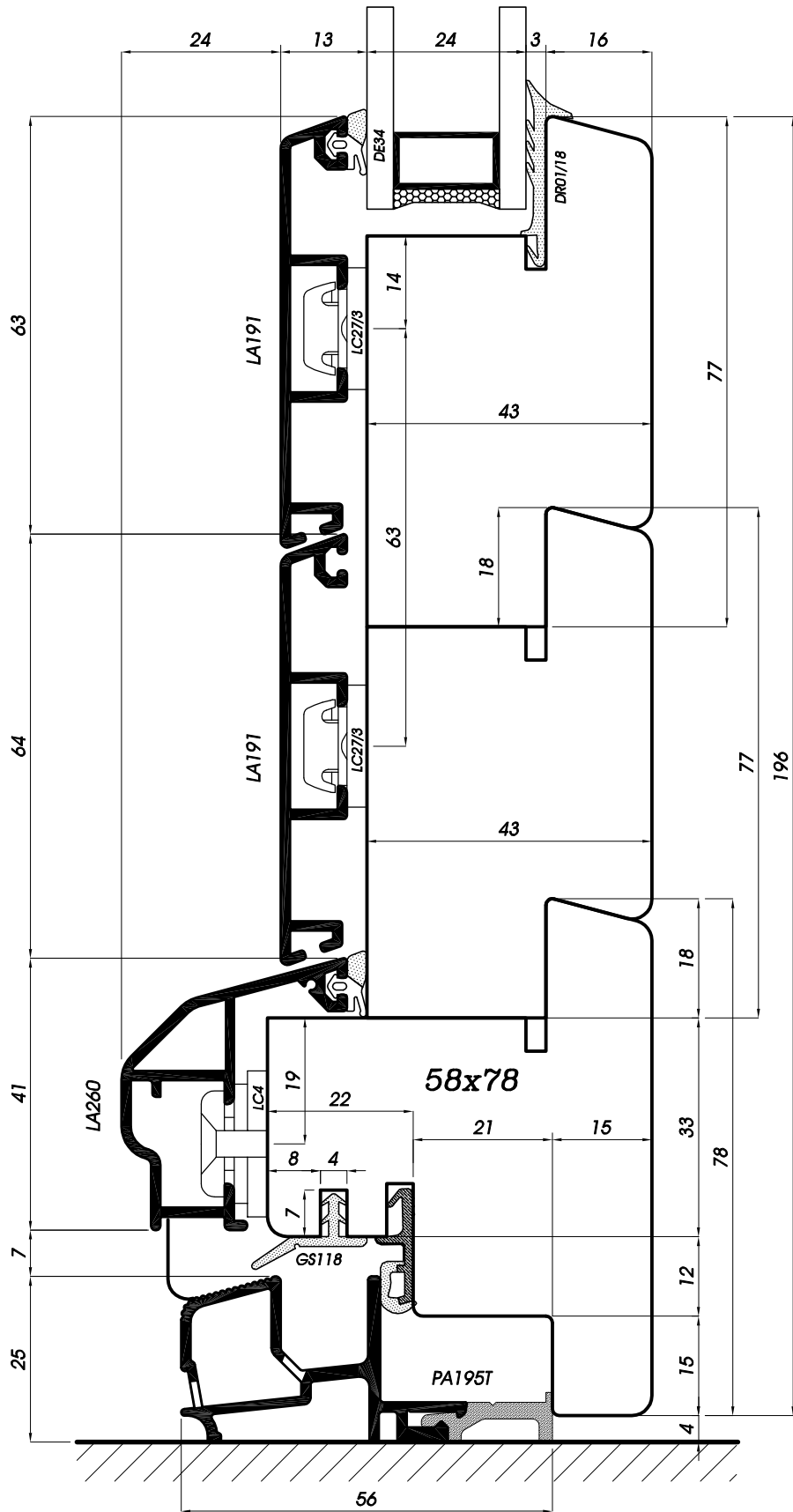

Sezione verticale traverso inferiore portafinestra con PA195T  
 Vertikalschnitt Balkontür quer unten mit PA195T  
 Sección vertical travesaño inferior puertaventana con PA195T  
 Coupe verticale traverse inférieure porte-fenêtre avec PA195T  
 Vertical section of the window-door's lower ledger with PA195T

LA261 - Anta legno 113mm

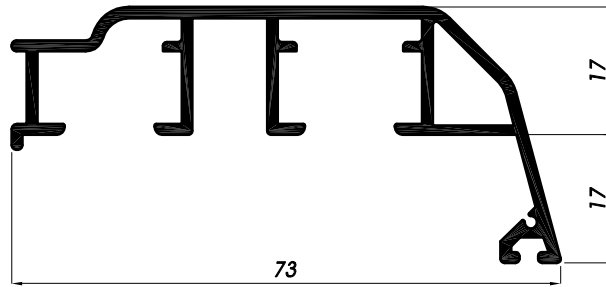

LA260 - Anta legno 81mm

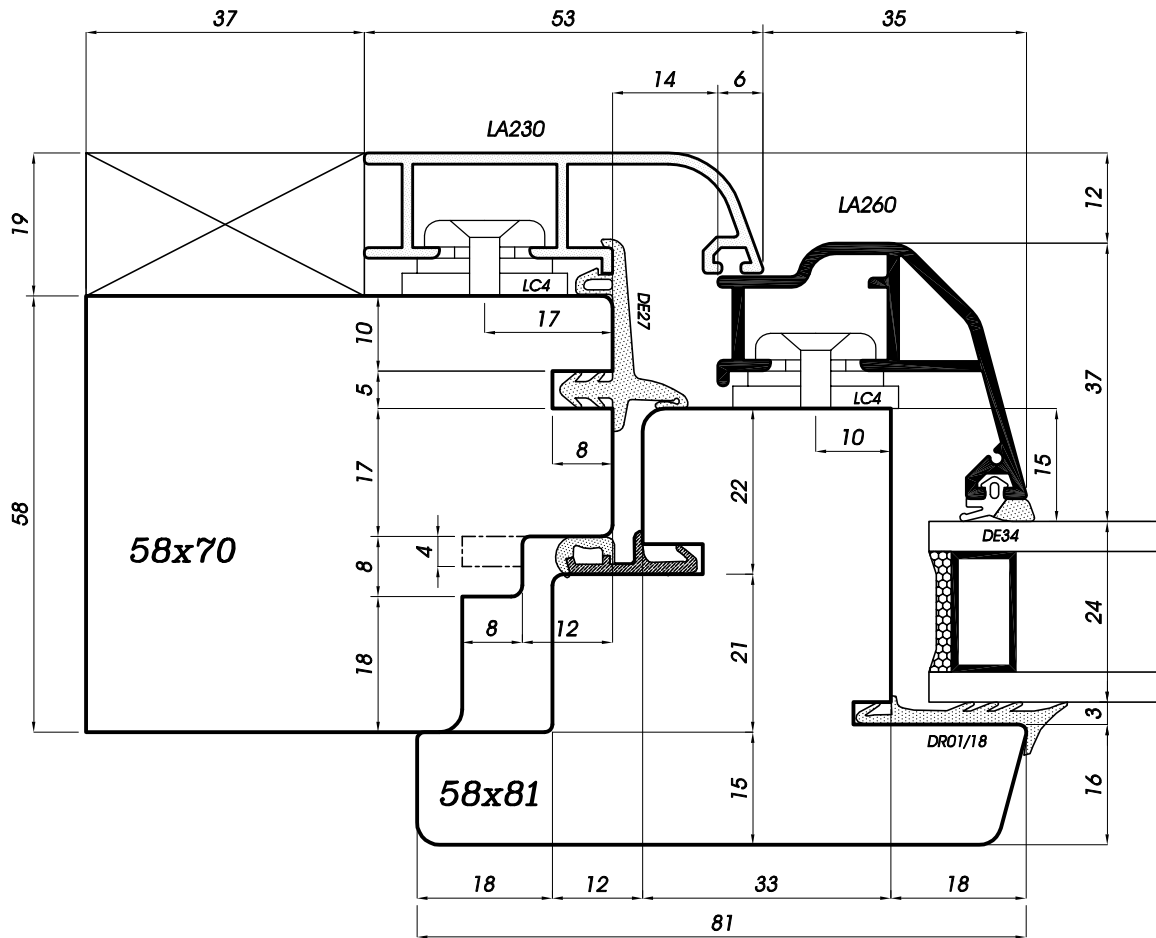
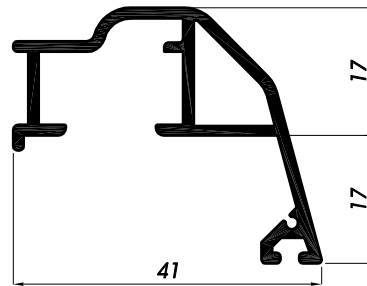

**Sezione orizzontale montanti laterali**  
**Horizontalschnitt senkrecht seitlich**  
**Sección horizontal de montantes laterales**  
**Coupe horizontale montants latéraux**  
**Horizontal section of the lateral jambs**

*5000/s Complanare*

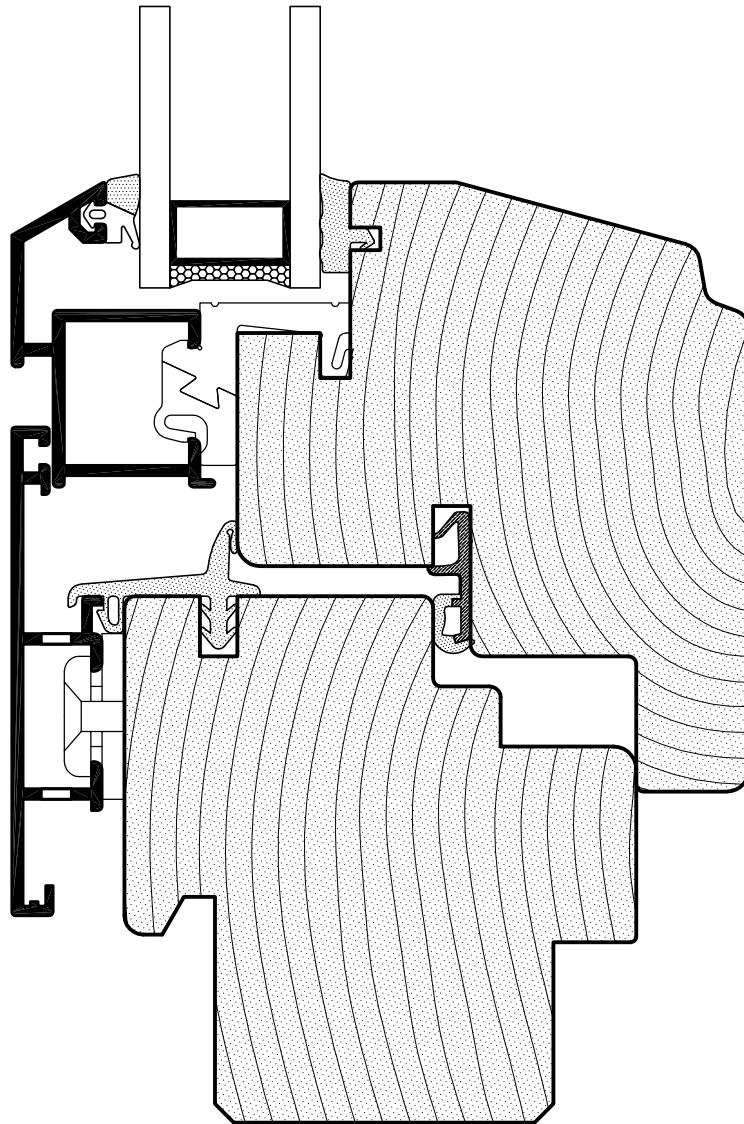

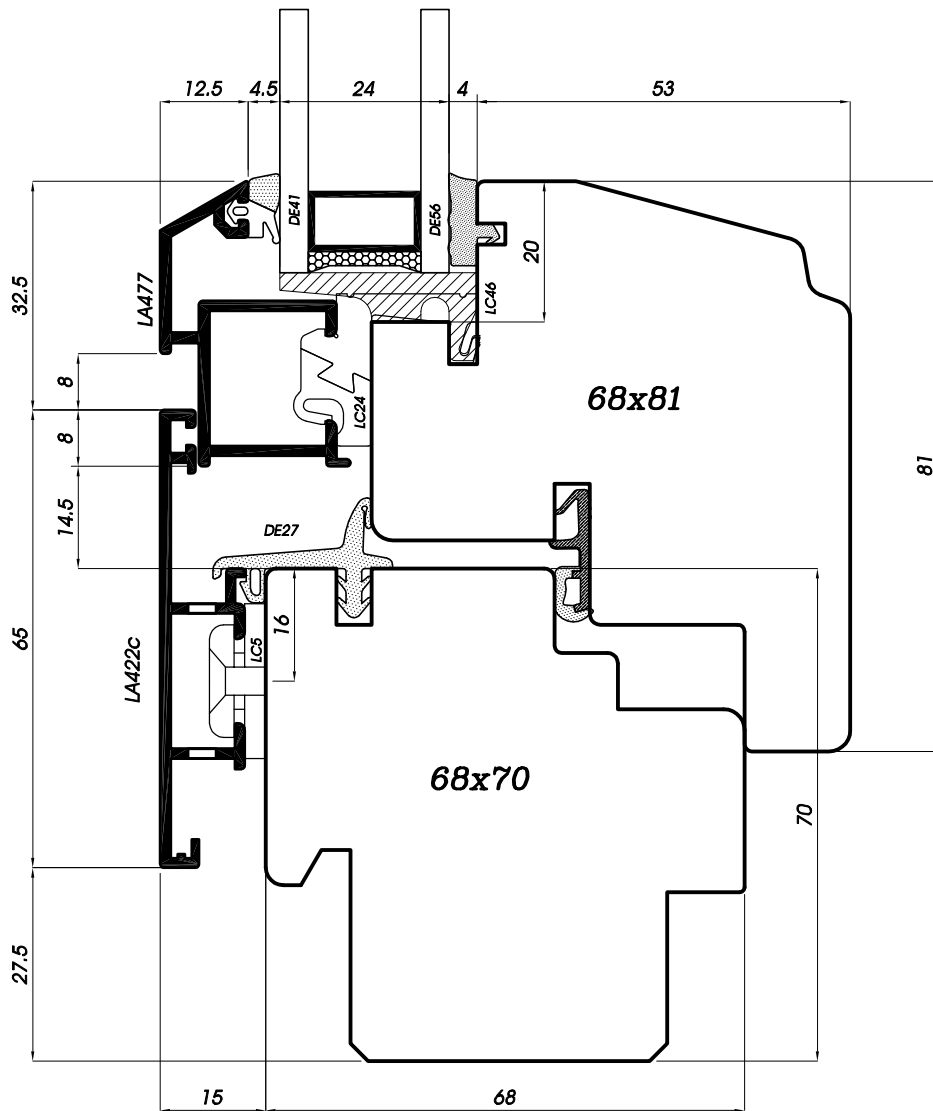
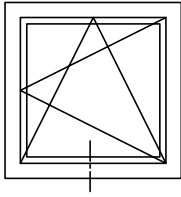

**Sezione verticale traverso inferiore finestra**  
**Vertikalschnitt Fenster quer unten**  
**Sección vertical travesaño inferior de la ventana**  
**Coupe verticale traverse inférieure fenêtre**  
**Vertical section of the window's lower ledger**



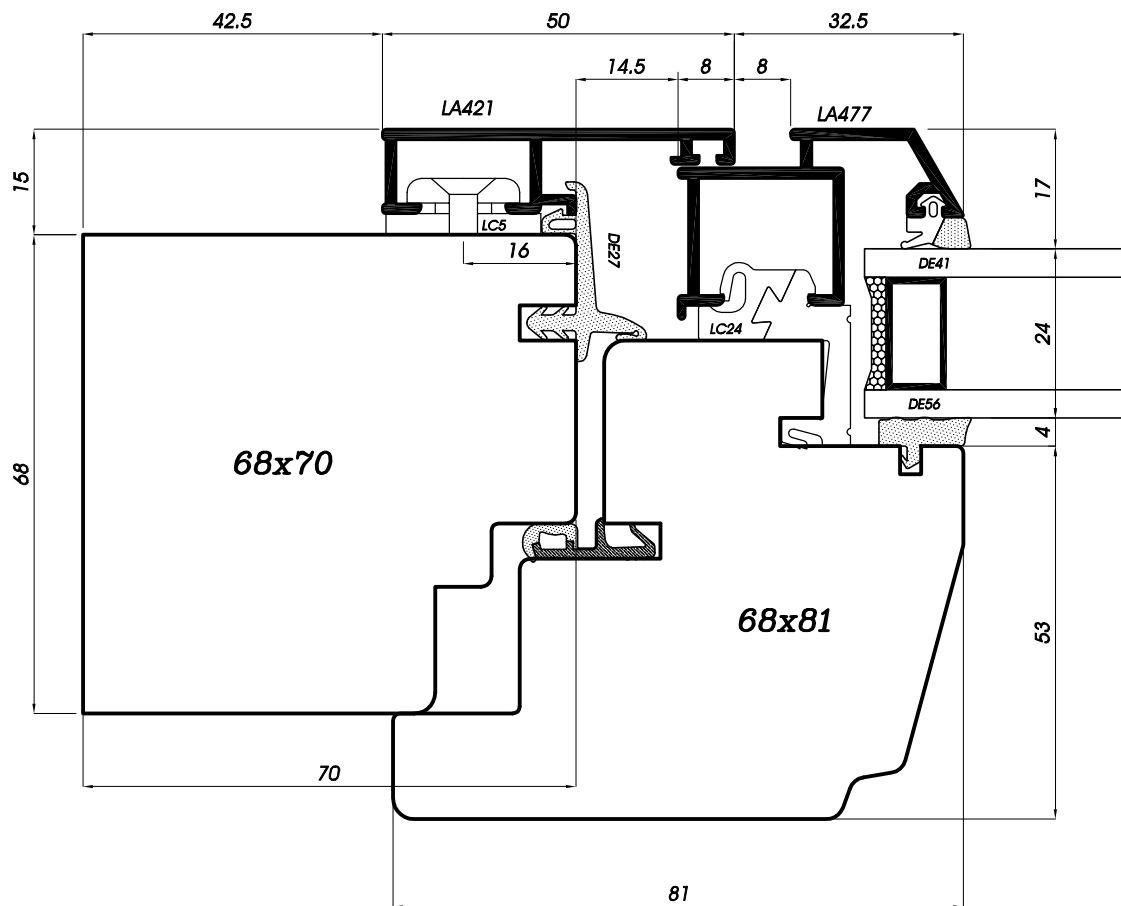
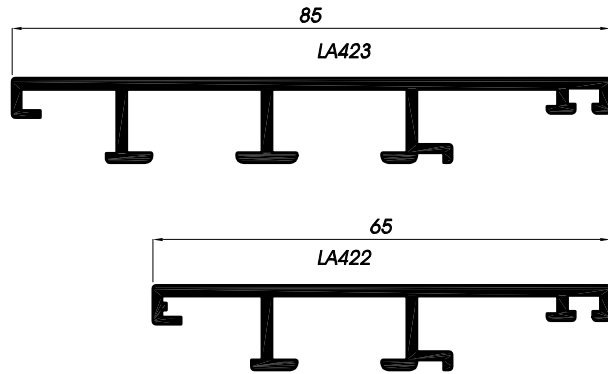
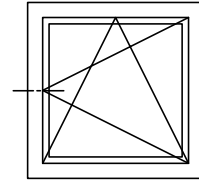

Sezione orizzontale montanti laterali  
 Horizontalschnitt senkrecht seitlich  
 Sección horizontal montantes laterales  
 Coupe horizontale montants latéraux  
 Horizontal section of the lateral jamb

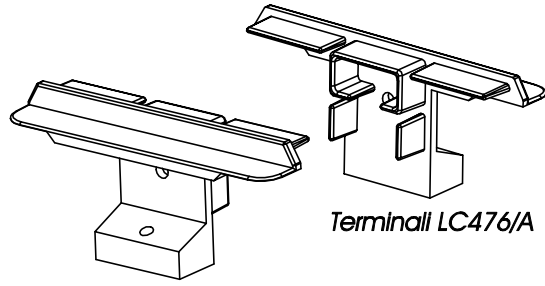
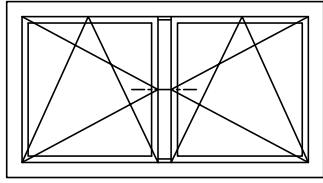

Terminali LC476/A

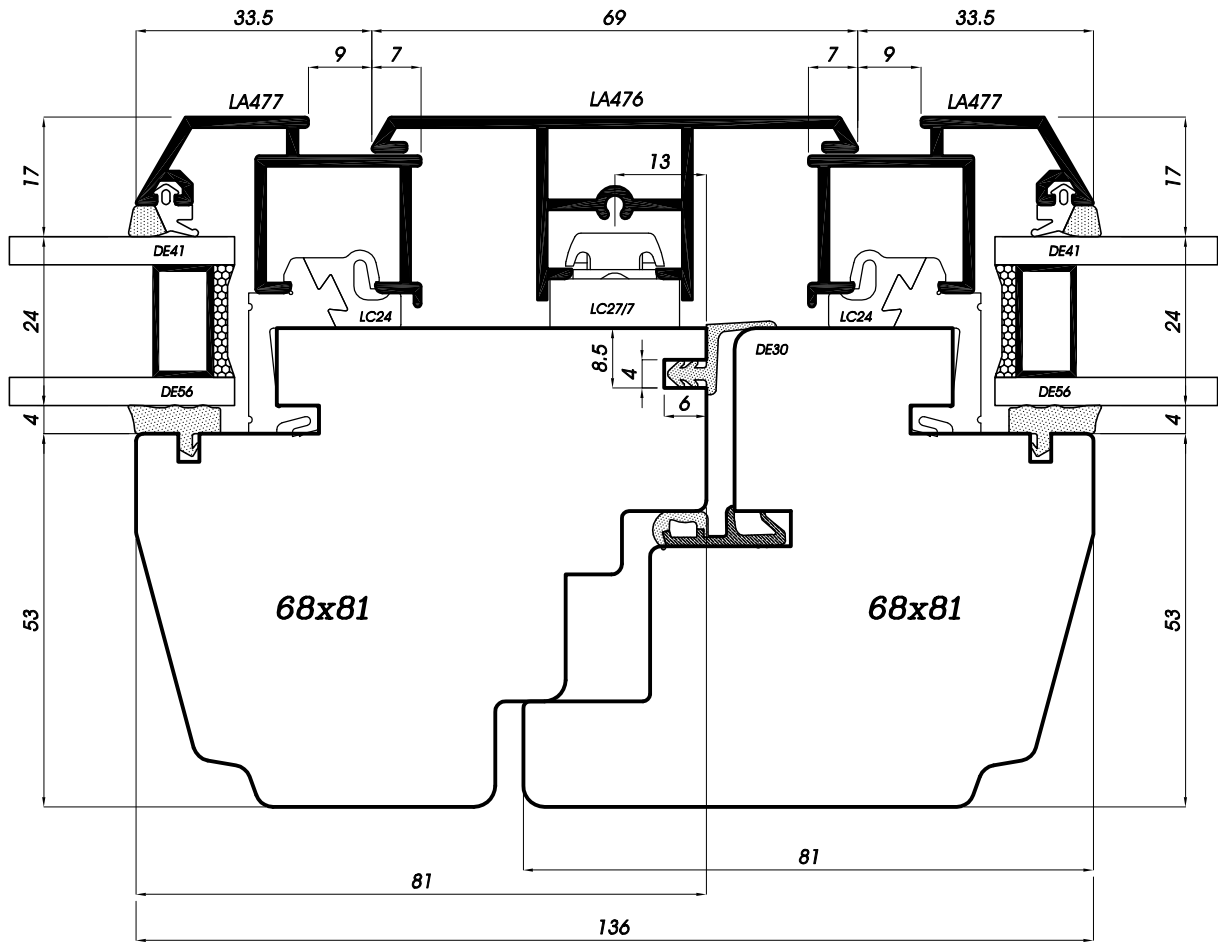

Sezione orizzontale chiusura centrale con profilo LA476  
 Horizontalschnitt Stulpprofil LA476  
 Sección horizontal del cierre central con perfil LA476  
 Coupe horizontale battement central avec profil LA476  
 Horizontal section of the middle clamp with profil LA476

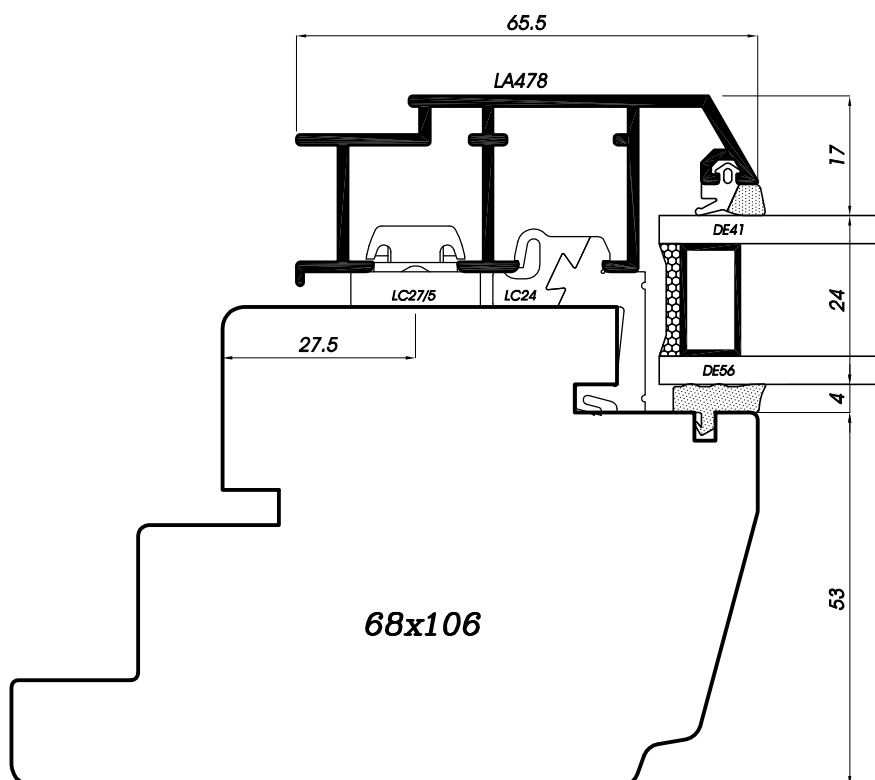
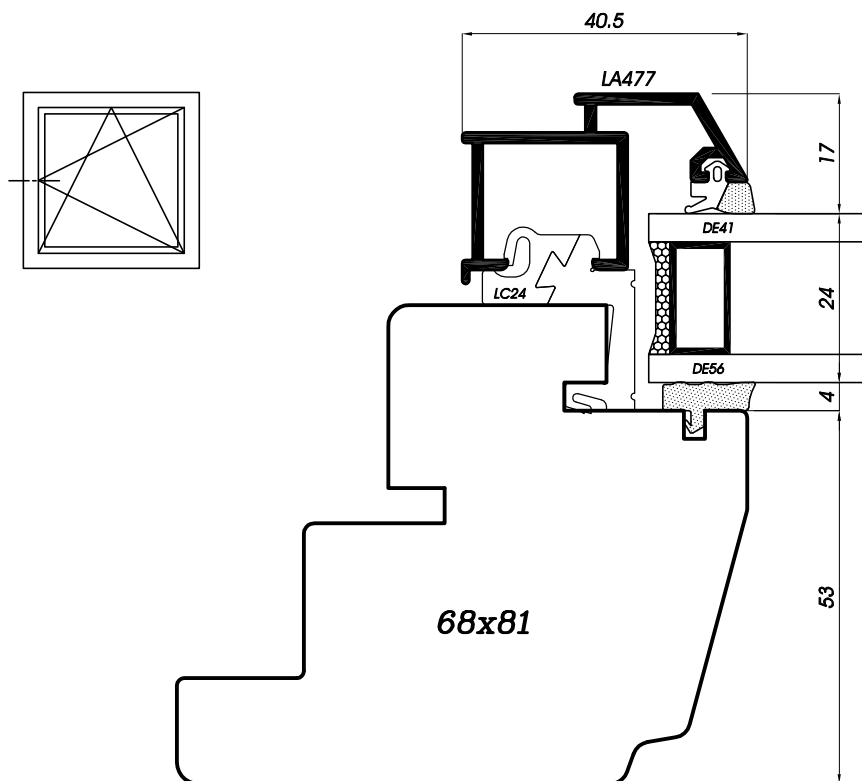

**Sezioni orizzontali battenti**  
**Horizontalschnitt Flügel**  
**Secciones horizontales hojas**  
**Coupes horizontales vantaux**  
**Horizontal section of the wings**

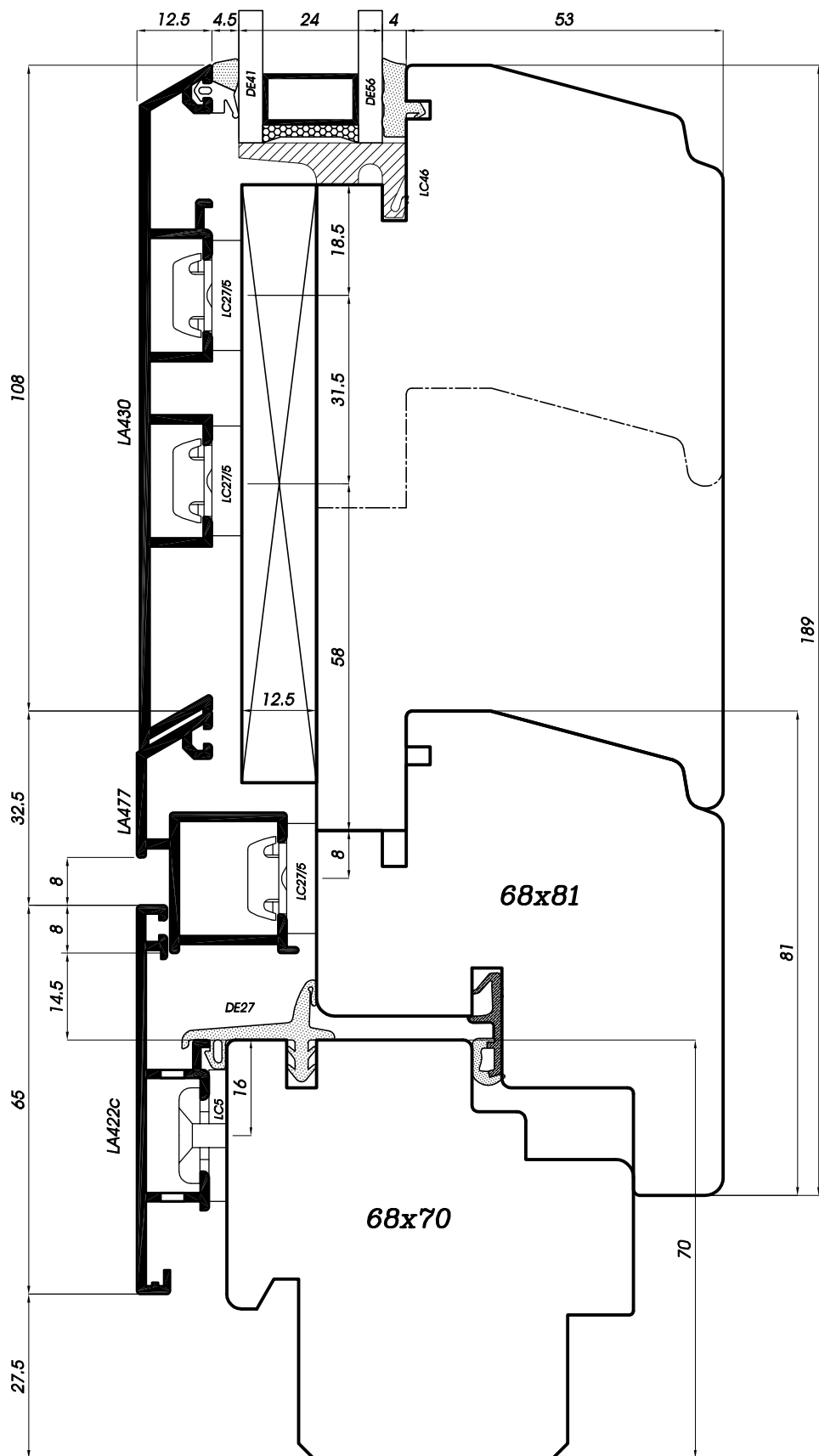

**Sezione verticale traverso inferiore portafinestra**  
**Vertikalschnitt Balkontür quer unten**  
**Sección vertical travesaño inferior puertaventana**  
**Coupe verticale traverse inférieure porte-fenêtre**  
**Vertical section of the window-door's lower ledger**

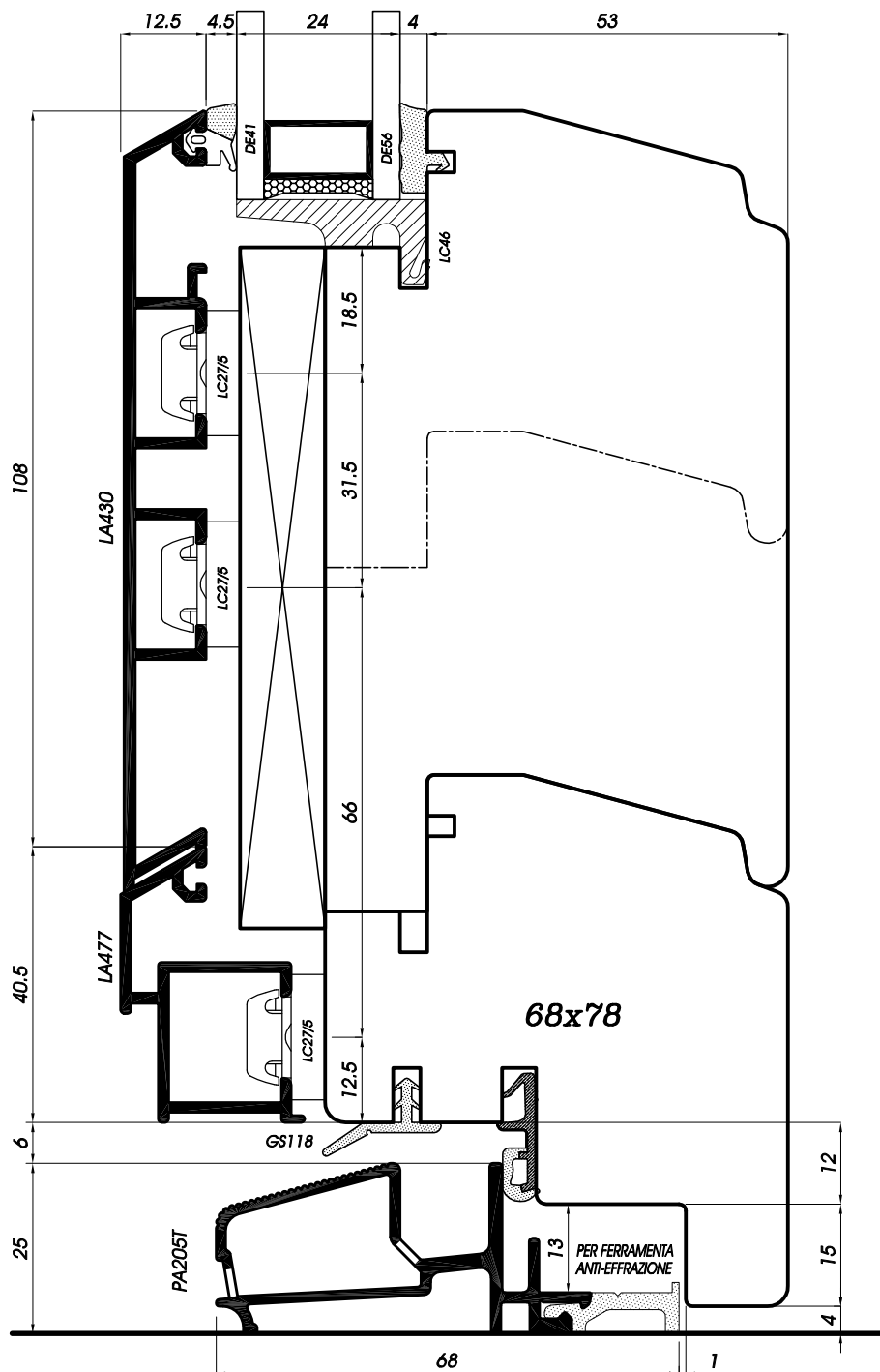

Sezione verticale traverso inferiore portafinestra con PA205T  
 Vertikalschnitt Balkontür quer unten mit PA205T  
 Sección vertical travesaño inferior puertaventana con PA205T  
 Coupe verticale traverse inférieure porte-fenêtre avec PA205T  
 Vertical section of the window-door's lower ledger with PA205T

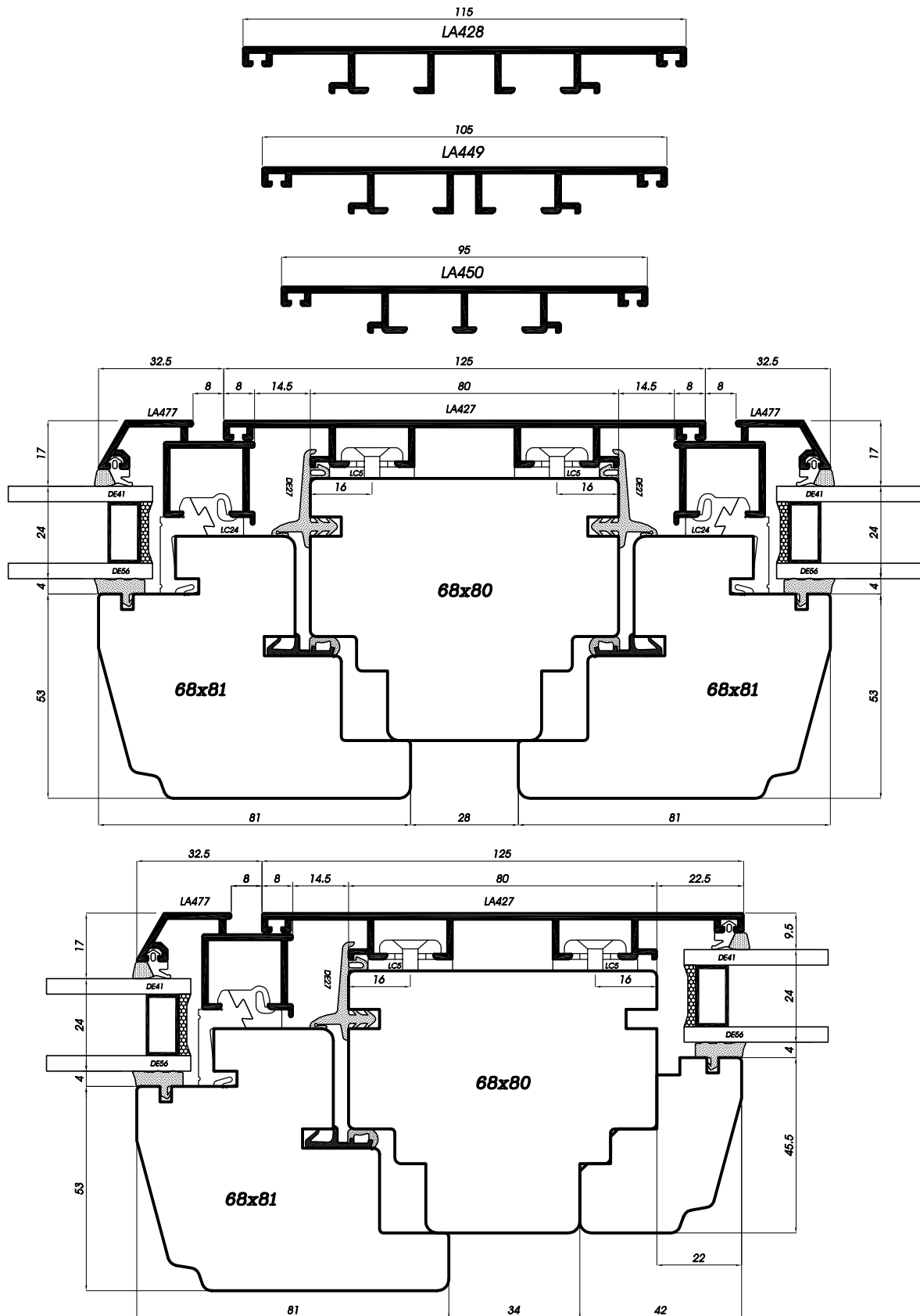

Sezione orizzontale montanti intermedi telaio  
 Horizontalschnitt Setzholz Rahmen  
 Sección horizontal montantes intermedios del marco  
 Coupe horizontale montants intermédiaires dormant  
 Horizontal section of the frame's middle jamba

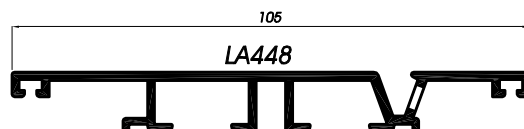
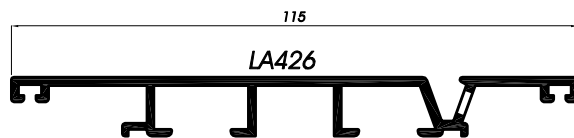
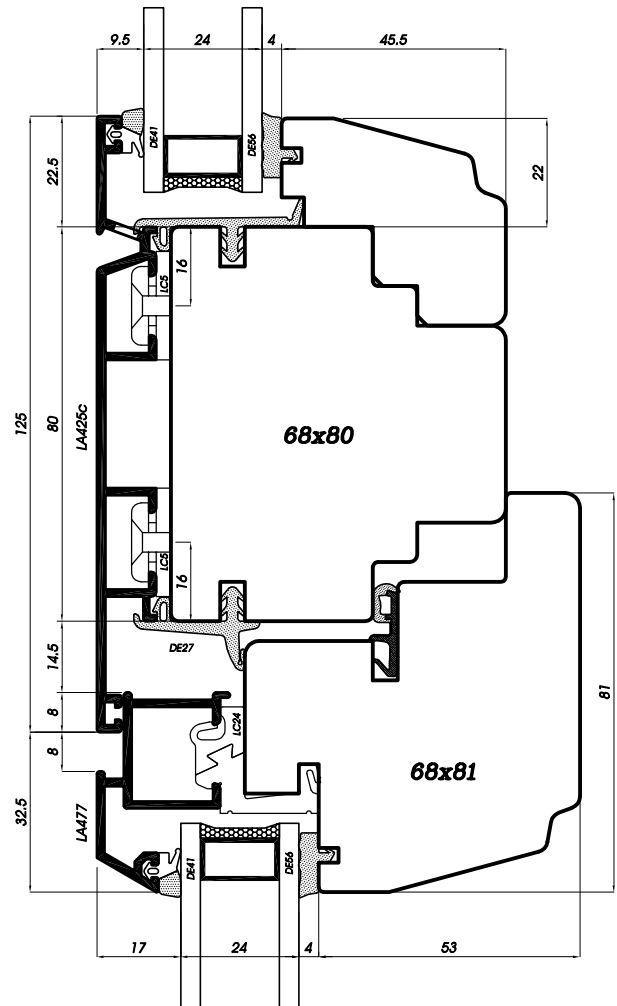
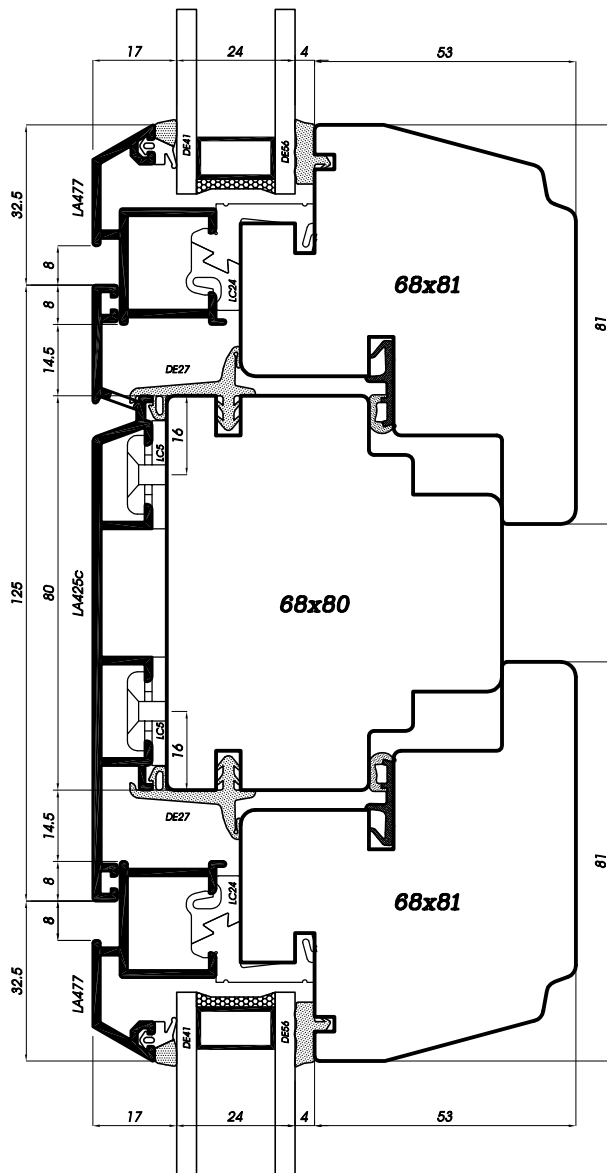

Sezione verticale traversi intermedi telaio  
 Vertikalschnitt Rahmensprossen  
 Sección vertical travesaños intermedios del marco  
 Coupe verticale des traverses intermédiaires du dormant  
 Vertical section of the frame's middle jambs

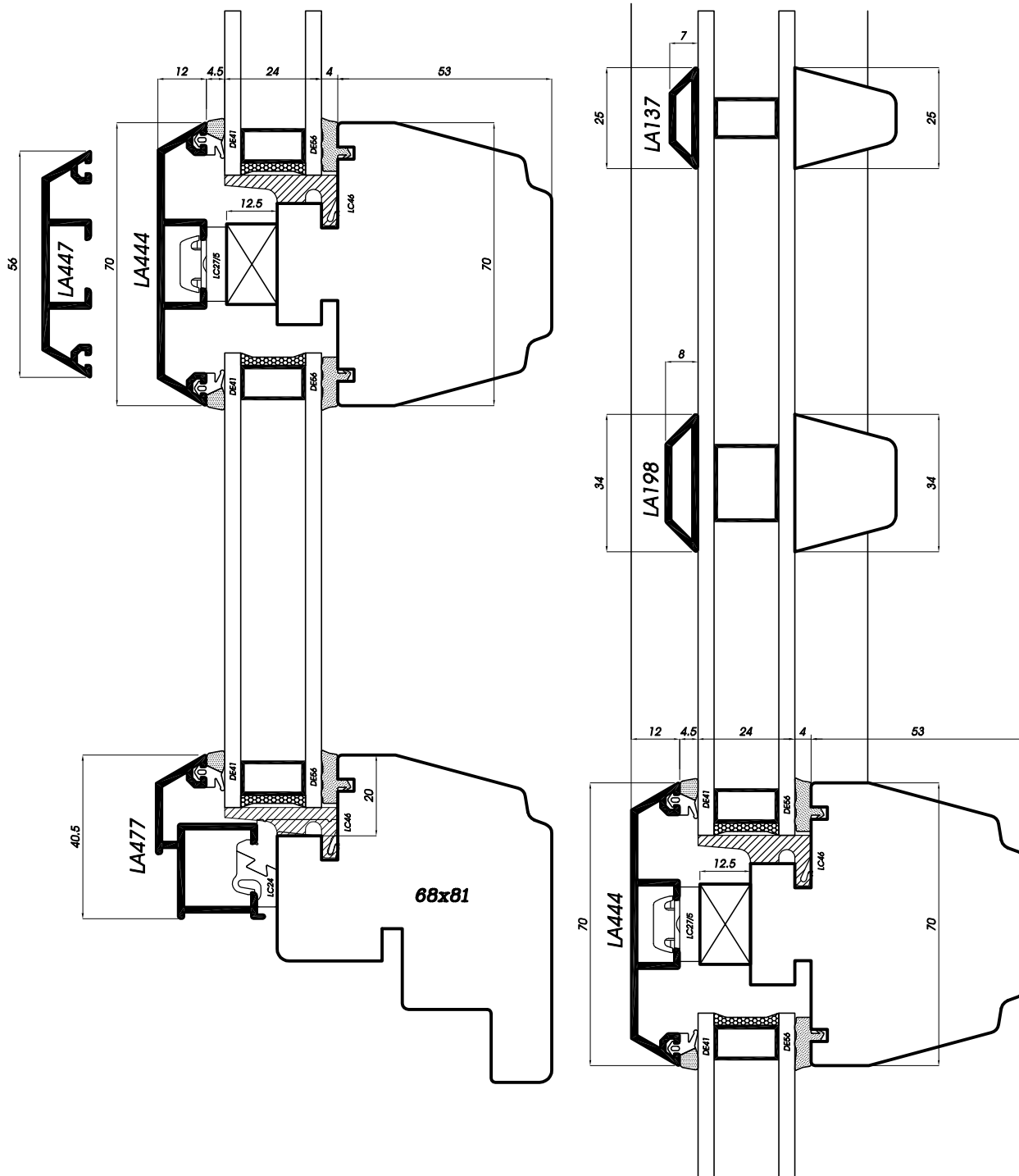

Sezione verticale traversi intermedi anta  
 Vertikalschnitt Flügelsprossen  
 Sección vertical travesaños intermedios hojas  
 Coupe verticale des traverses intermédiaires du vantail  
 Vertical section of the wing's middle jambs



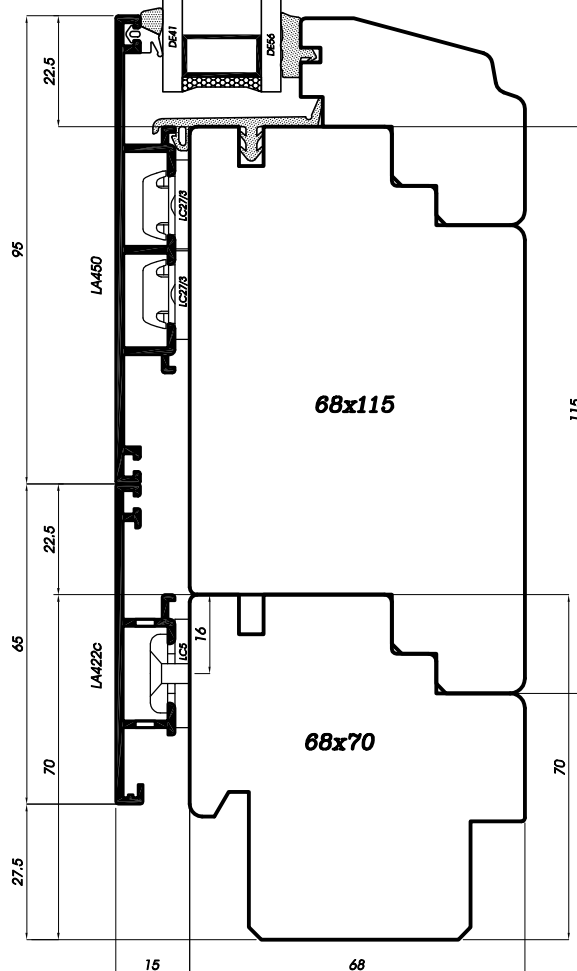
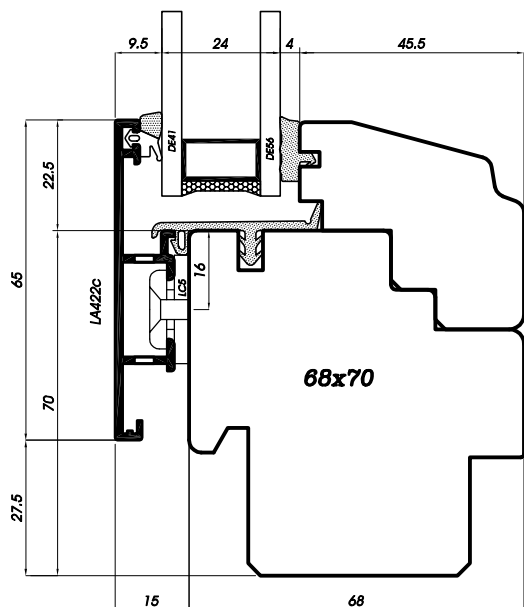
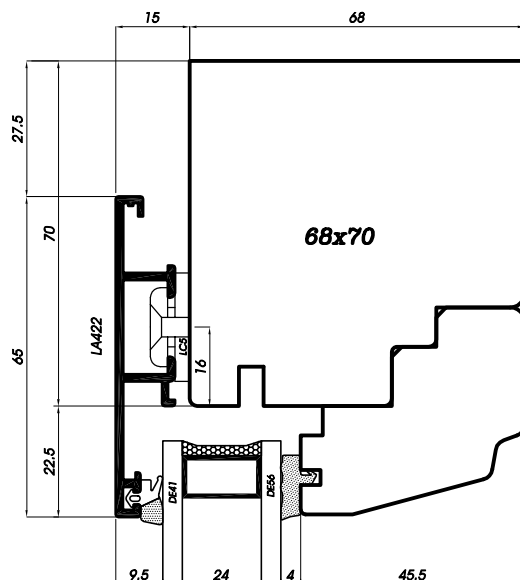
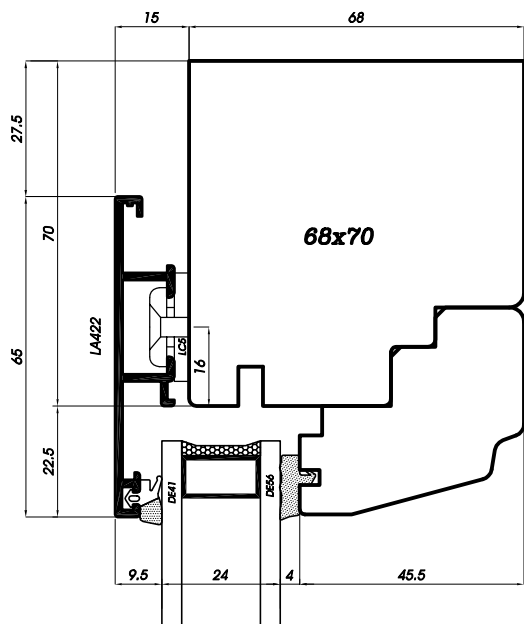

**Sezione verticale finestra e portafinestra con vetro fisso**  
**Vertikalschnitt Fenster und Balkontür mit Fixverglasung**  
**Sección vertical ventana y puertaventana con cristal fijo**  
**Coupe verticale fenêtre et porte-fenêtre avec vitre fixe**  
**Vertical section of the window and window-door with fixed glass**

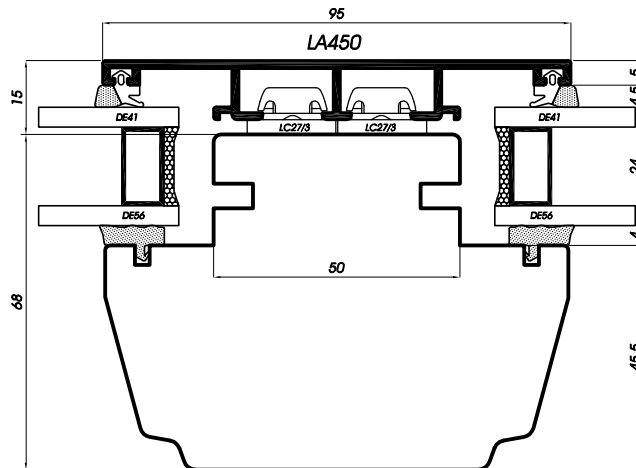
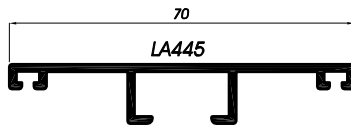
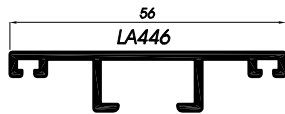
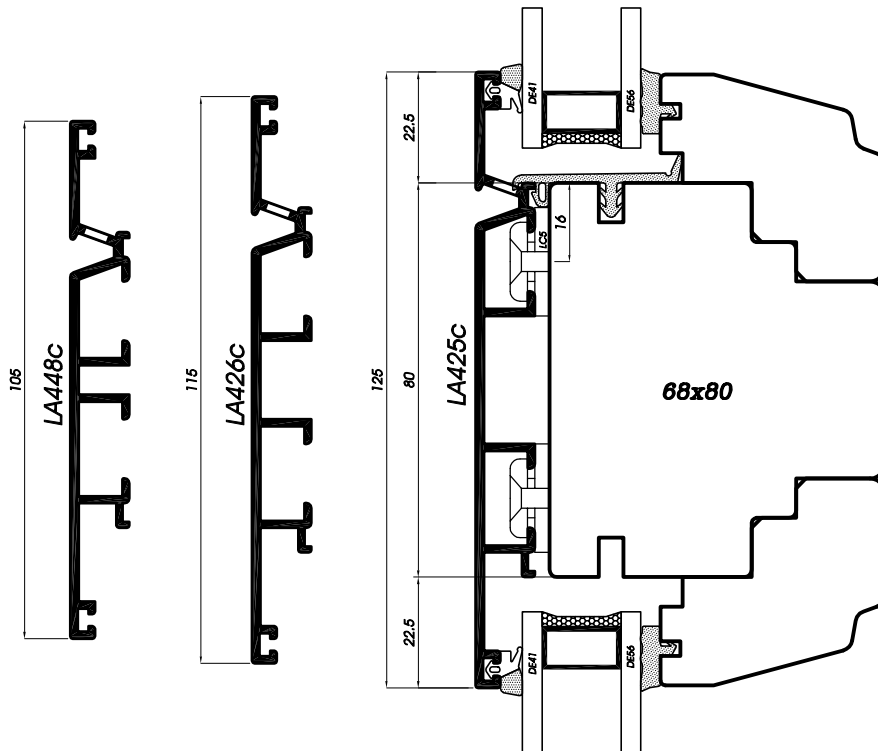

**Sezione orizzontale e verticale traversi intermedi telaio**  
**Horizontal- und Vertikalschnitt Rahmensprossen**  
**Sección horizontal y vertical travesaños intermedios del marco**  
**Coupe horizontale et verticale des traverses intermédiaires du dormant**  
**Horizontal and vertical section of the frame's middle ledgers**

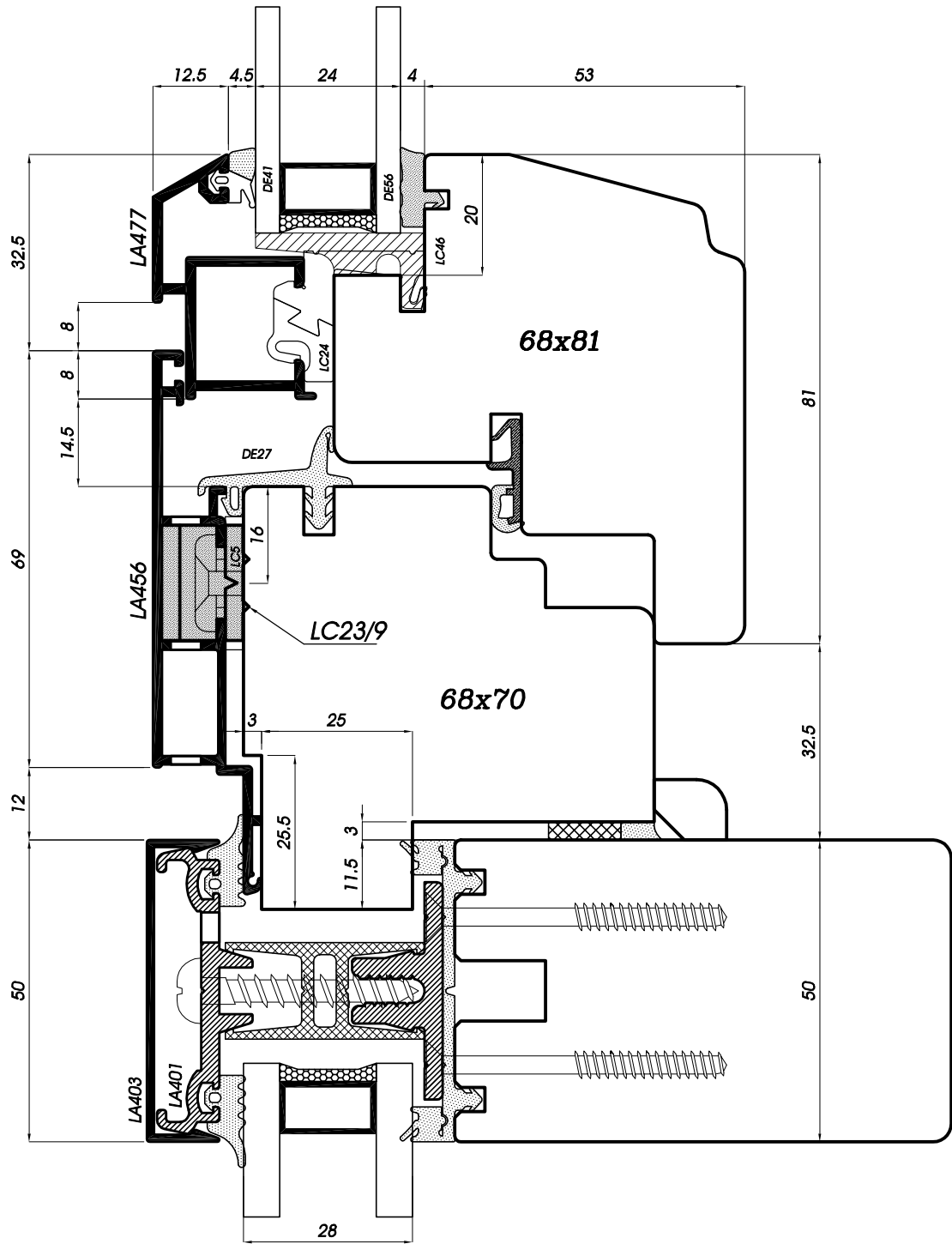

**ATTENZIONE: Il profilo LA456 deve essere asolato a misura dopo aver tagliato il pezzo**

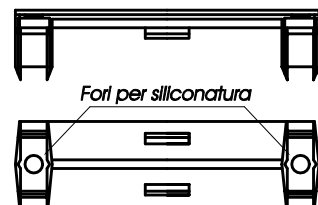

Sezione verticale traversi con facciata Unitherm  
 Vertikalschnitt Fassade Unitherm - Riegel-  
 Sección vertical travesaños con fachada Unitherm  
 Coupe verticale des traverses avec façade Unitherm  
 Vertical section of the ledgers with Unitherm curtain wall

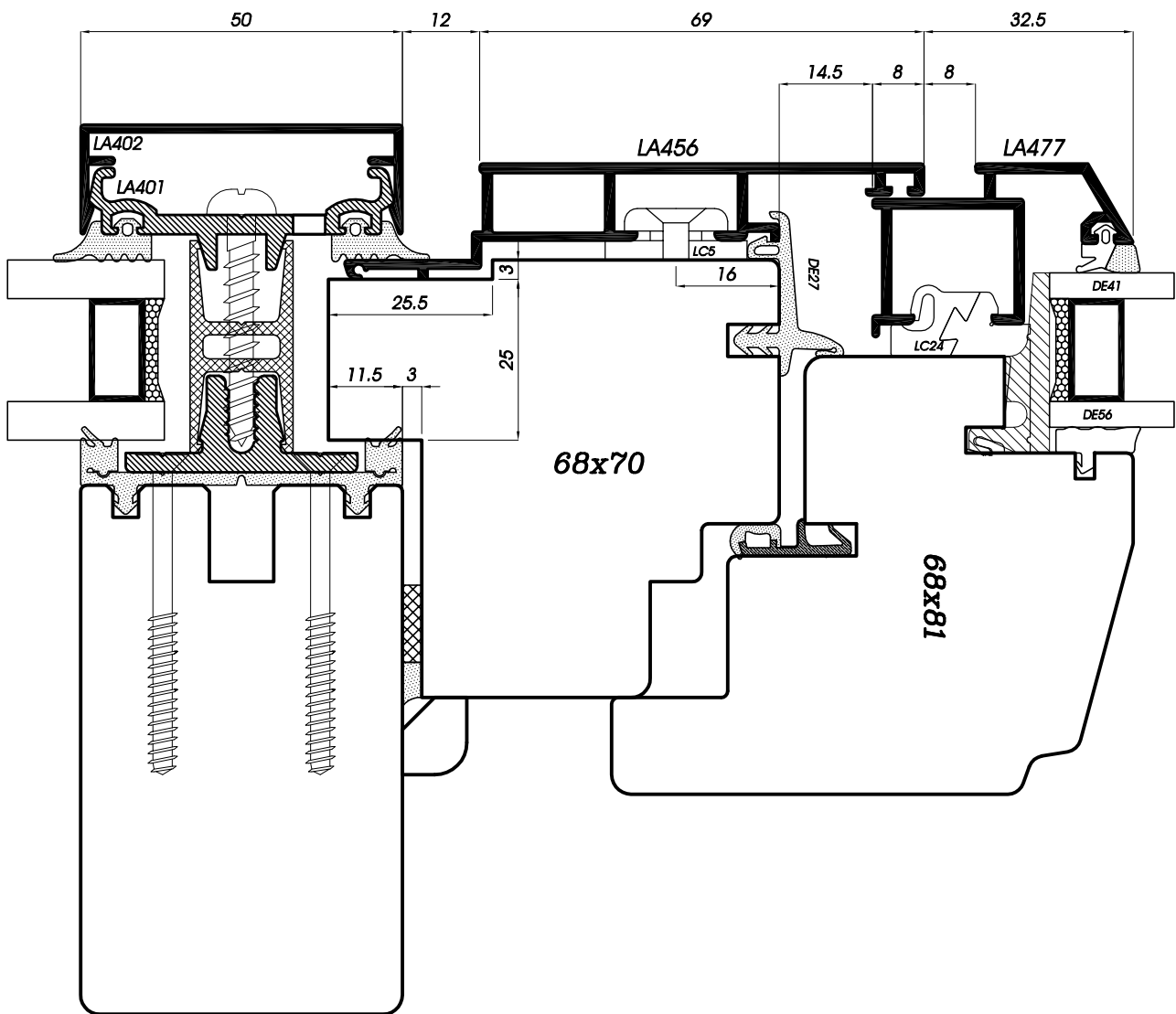

**Sezione orizzontale montanti con facciata Unitherm**  
**Horizontalschnitt Fassade Unitherm - Pfosten**  
**Sección horizontal montantes con fachada Unitherm**  
**Coupe horizontale des montants avec façade Unitherm**  
**Horizontal section of the ledgers with Unitherm curtain wall**

*Verbund 5000/s Complanare*

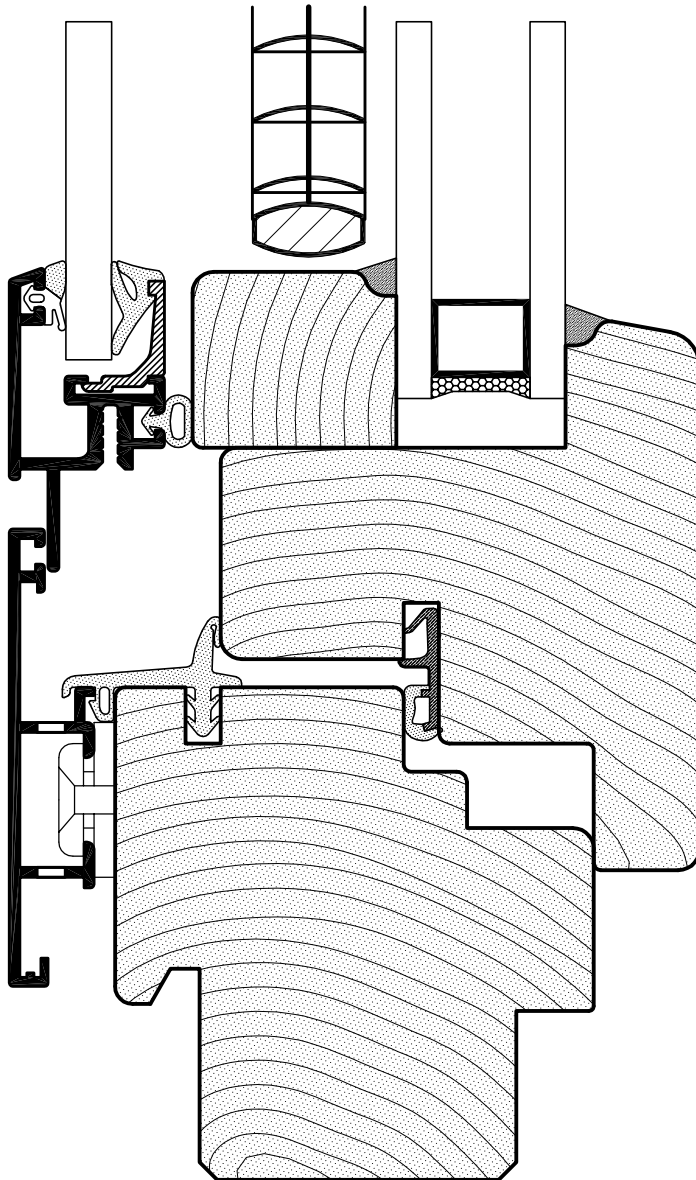

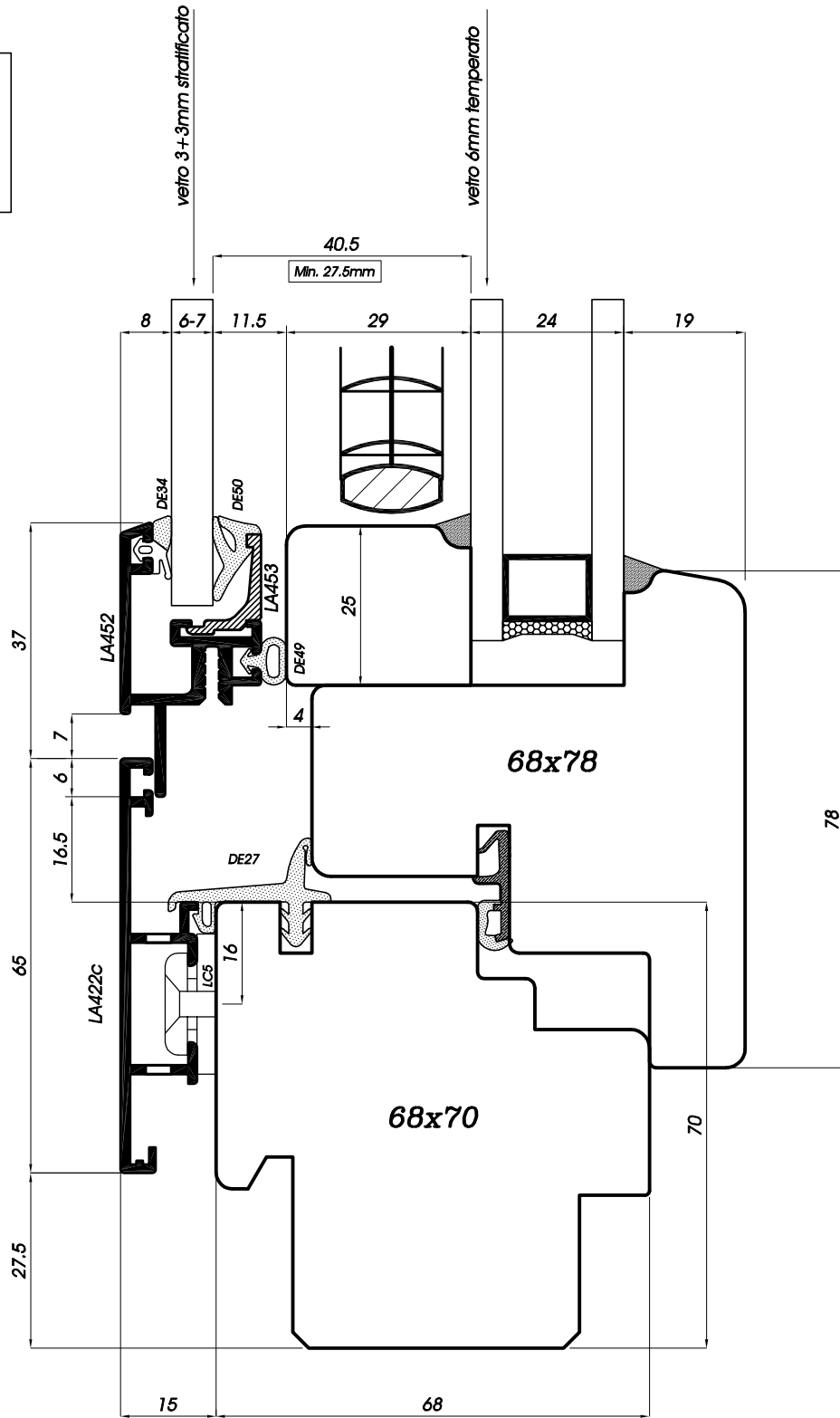
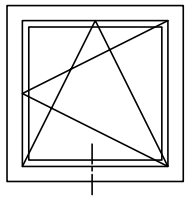

Sezione verticale traverso inferiore finestra  
 Vertikalschnitt Fenster quer unten  
 Sección vertical travesaño inferior de la ventana  
 Coupe verticale traverse inférieure fenêtre  
 Vertical section of the window's lower ledge

GU - TIPP 821

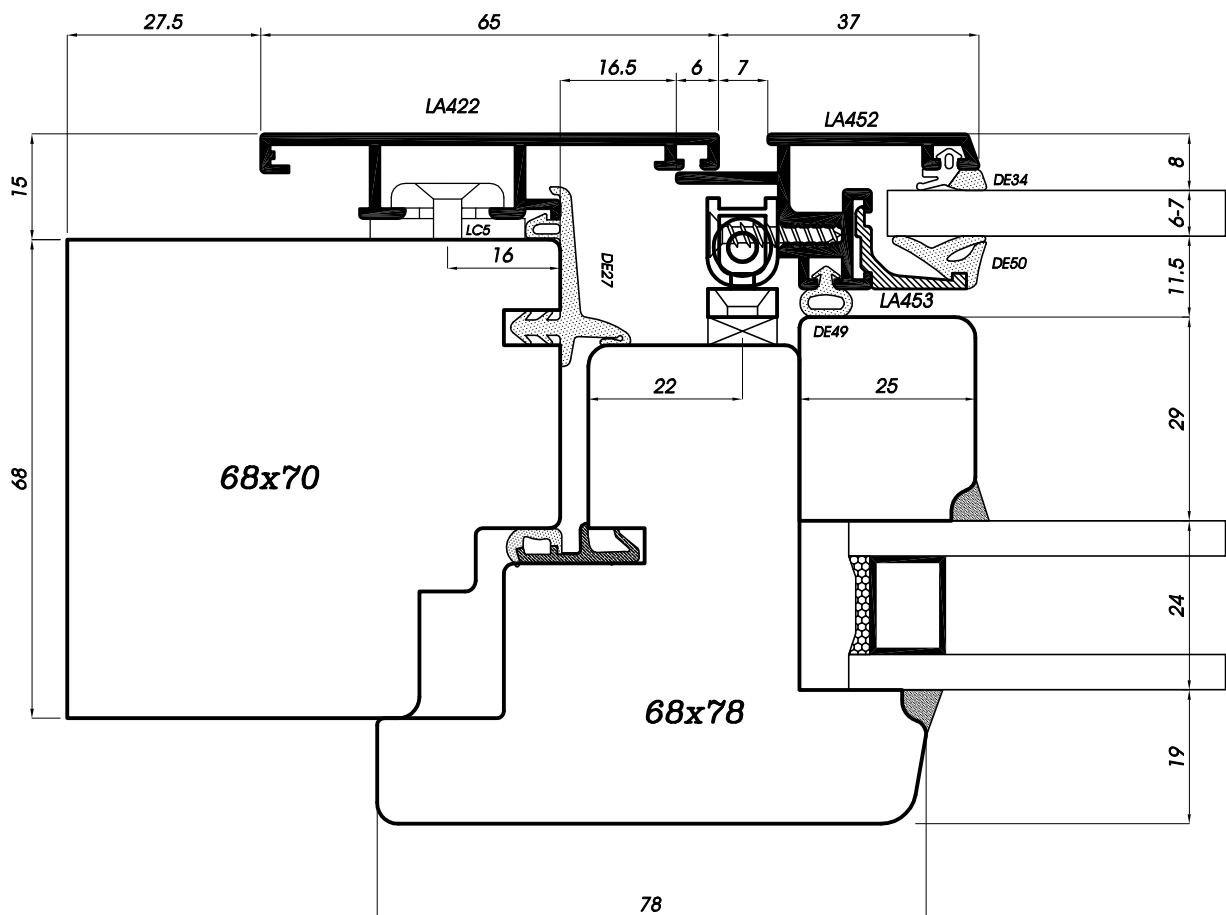
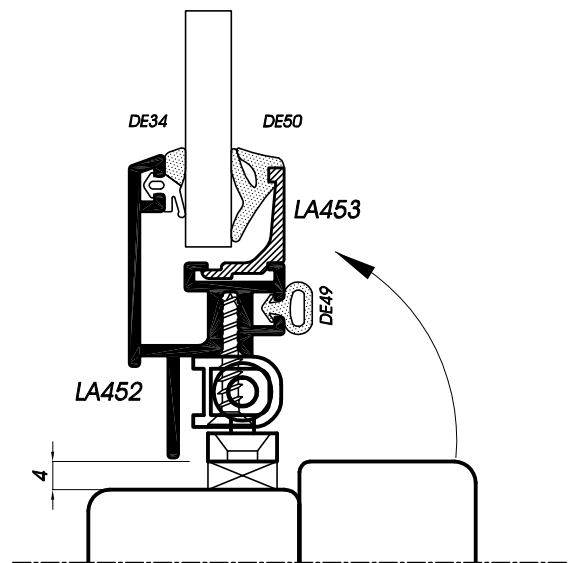
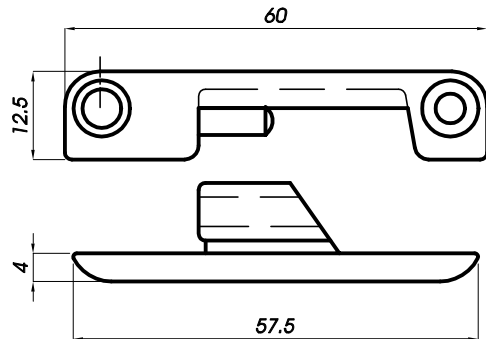

Sezione orizzontale montante laterale  
Horizontalschnitt senkrecht seitlich  
Sección horizontal montante lateral  
Coupe horizontale du montant latéral  
Horizontal section of the lateral jamb

GU - TOPP 47

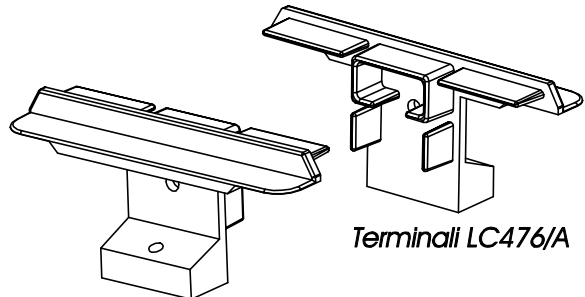
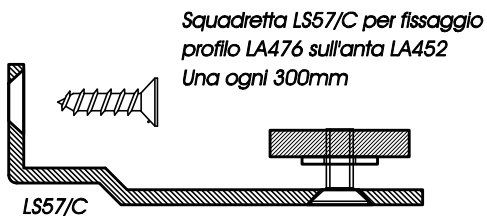
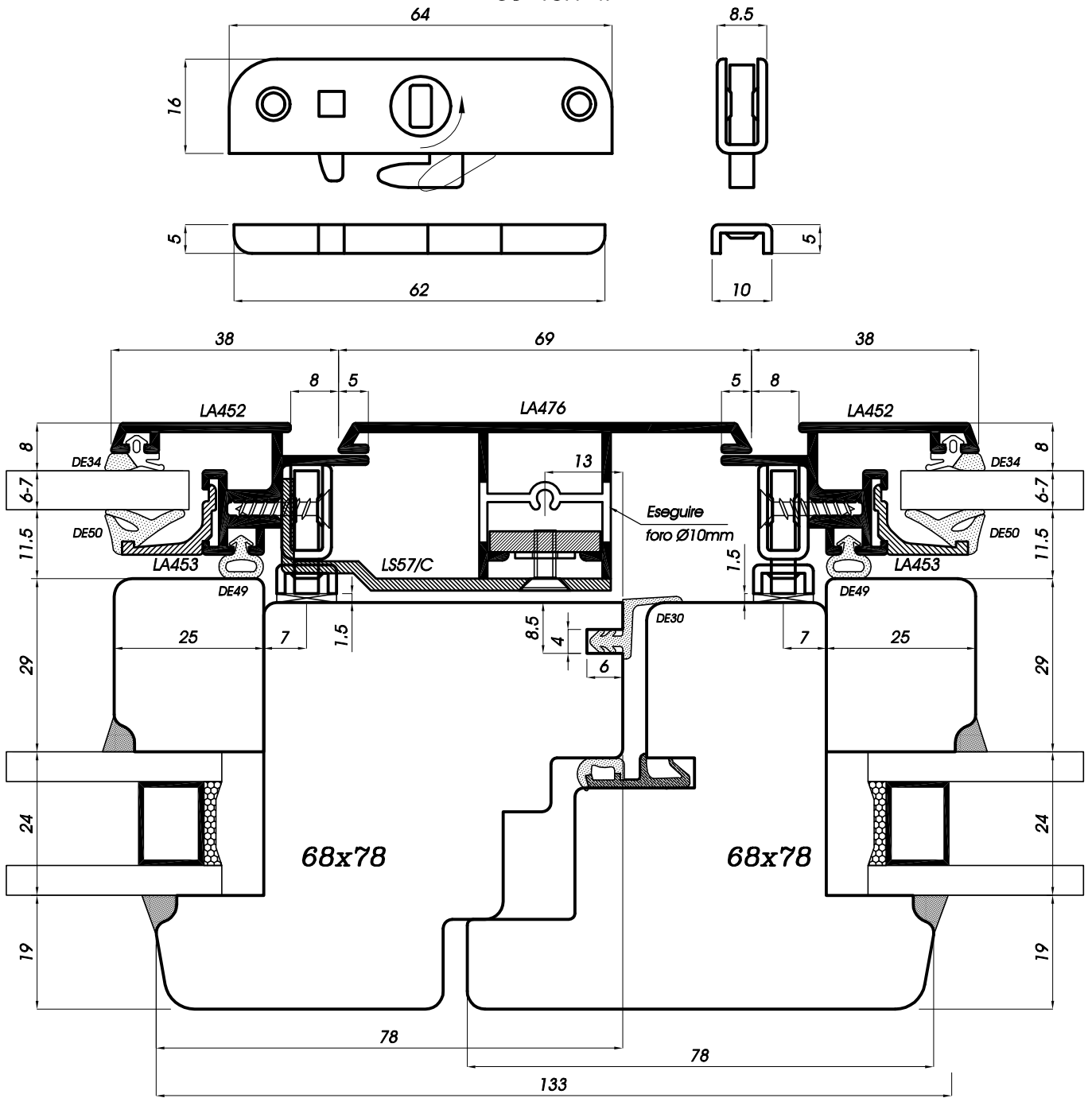

Sezione orizzontale chiusura centrale con profilo LA476  
 Horizontalschnitt Stulprofil LA476  
 Sección horizontal del cierre central con perfil LA476  
 Coupe horizontal battement central avec profil LA476  
 Horizontal section of the middle clamp with profile LA476



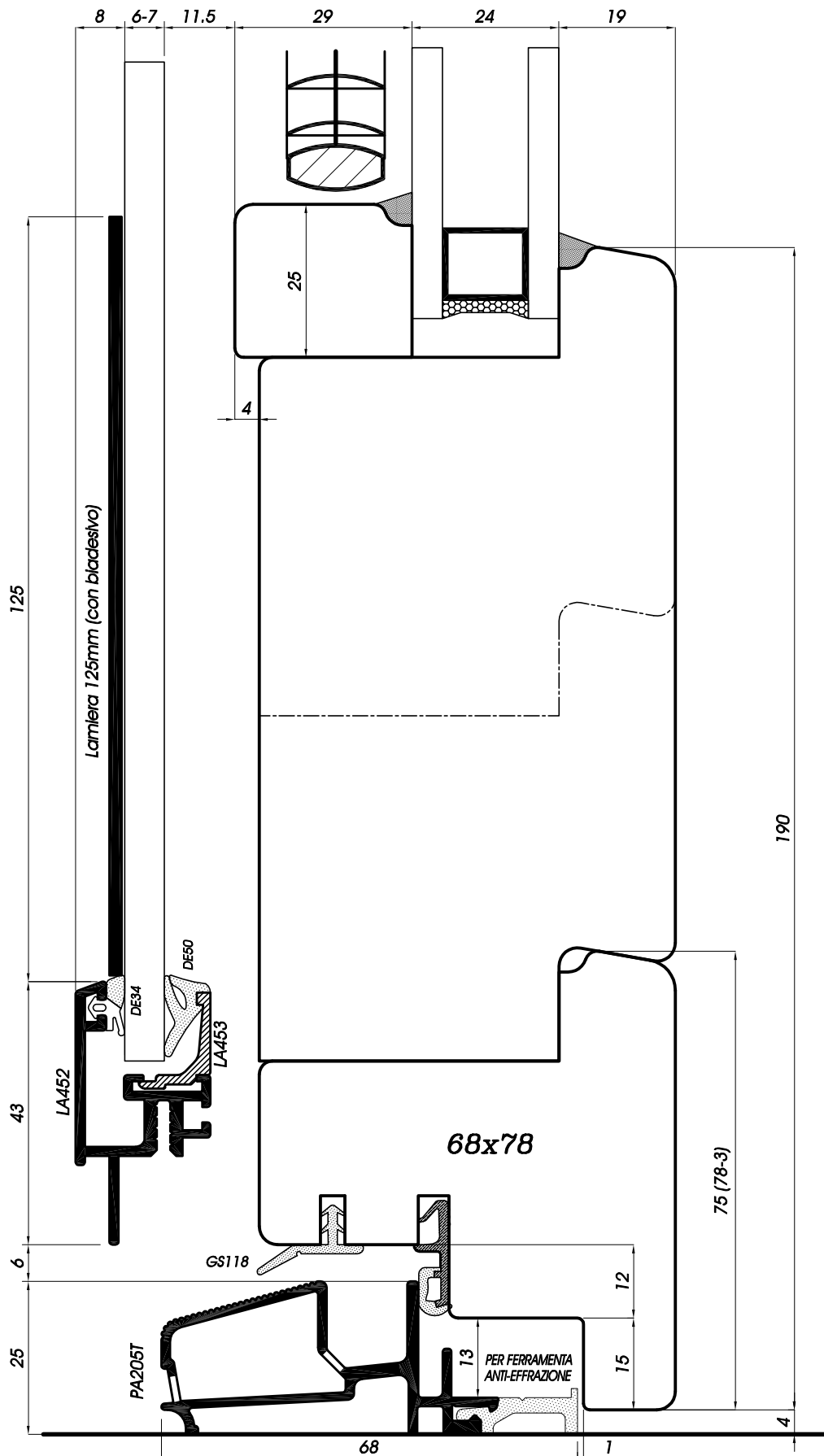

Sezione verticale traverso inferiore portafinestra con PA205T  
 Vertikalschnitt Balkontür quer unten mit PA205T  
 Sección vertical travesaño inferior puertaventana con PA205T  
 Coupe verticale traverse inférieure porte-fenêtre avec PA205T  
 Vertical section of the window-door's lower ledger with PA205T

SISTEMI PER SERRAMENTI

**UNIFORM**

*Sistema IV68 – SOFT*

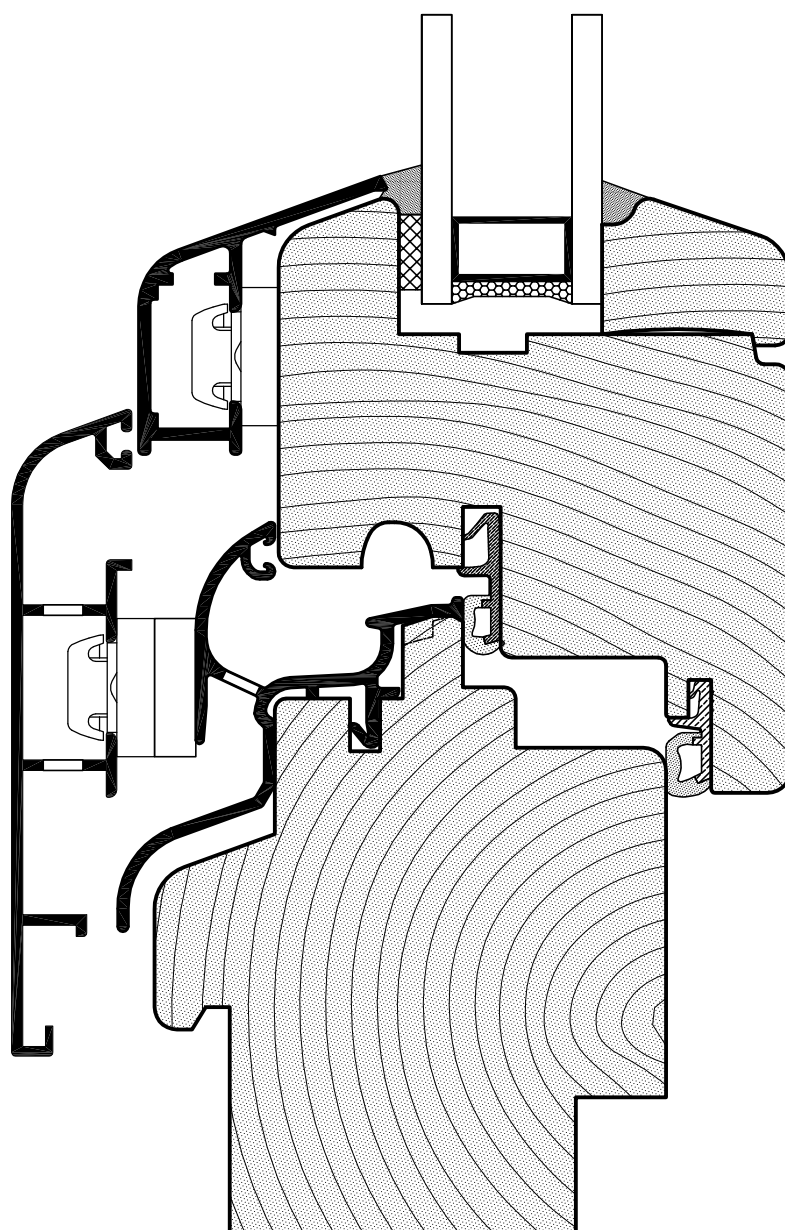

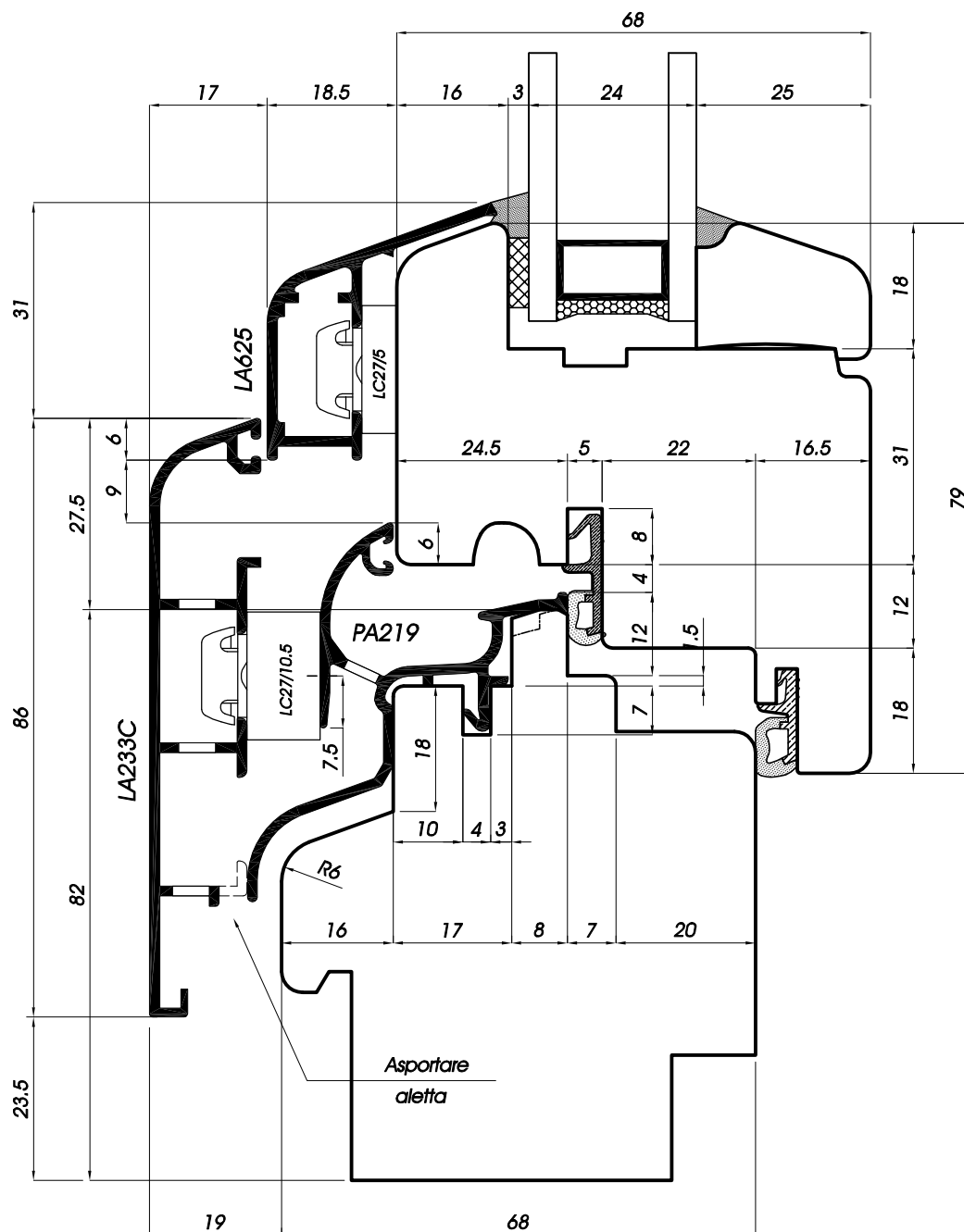

Sezione verticale traverso inferiore finestra  
 Vertikalschnitt Fenster unten quer  
 Sección vertical travesaño inferior de la ventana  
 Coupe verticale traverse inférieure fenêtre  
 Vertical section of the window's lower ledge

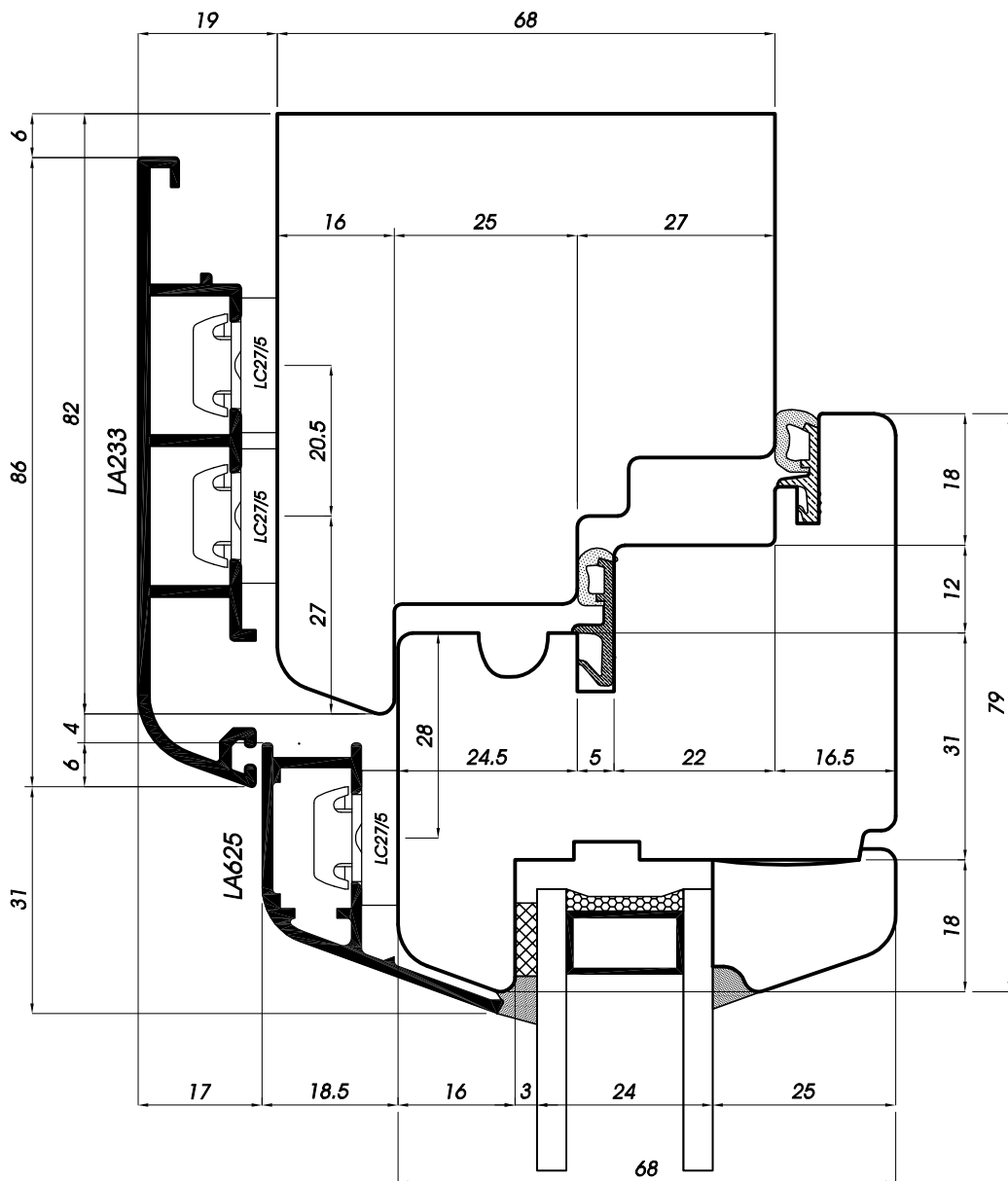

Sezione verticale traverso superiore finestra  
 Vertikalschnitt Fenster oben quer  
 Sección vertical travesaño superior de la ventana  
 Coupe verticale traverse supérieure fenêtré  
 Vertical section of the window's upper ledge

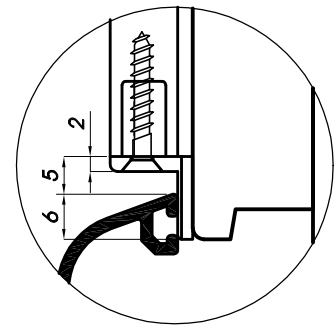
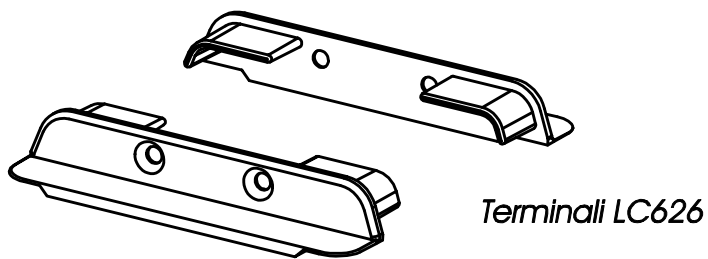
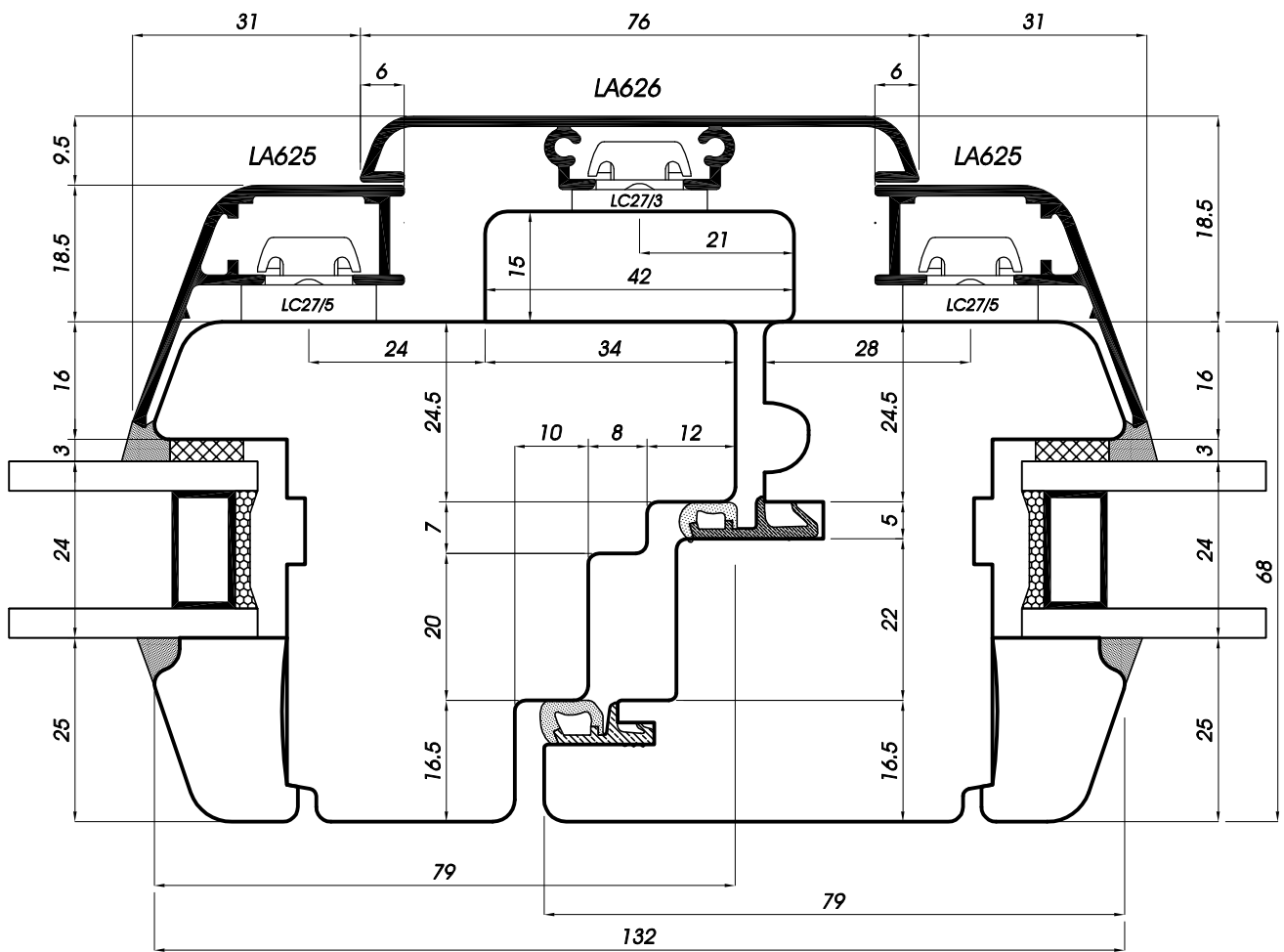

Sezione orizzontale chiusura centrale con profilo LA626  
 Horizontalschnitt Stulpprofil LA626  
 Sección horizontal del cierre central con perfil LA626  
 Coupe horizontal battement central avec profil LA626  
 Horizontal section of the middle clamp with profile LA626

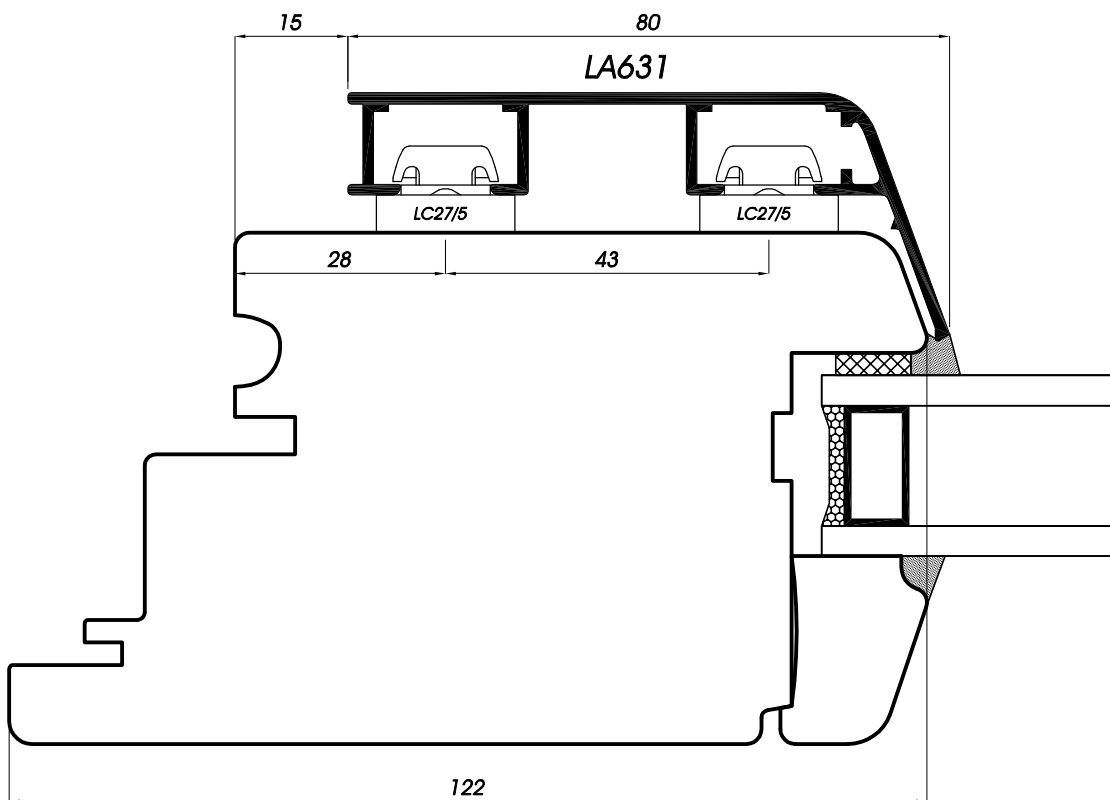
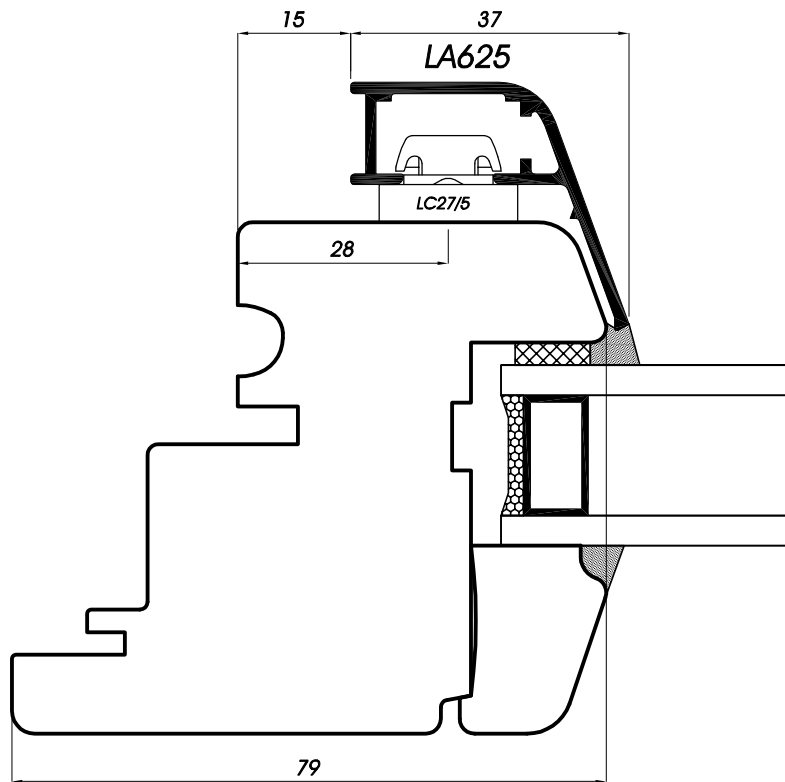

**Sezioni orizzontali battenti**  
**Horizontalschnitt Flügel**  
**Secciones horizontales hojas**  
**Coupes horizontales vantaux**  
**Horizontal section of the wings**

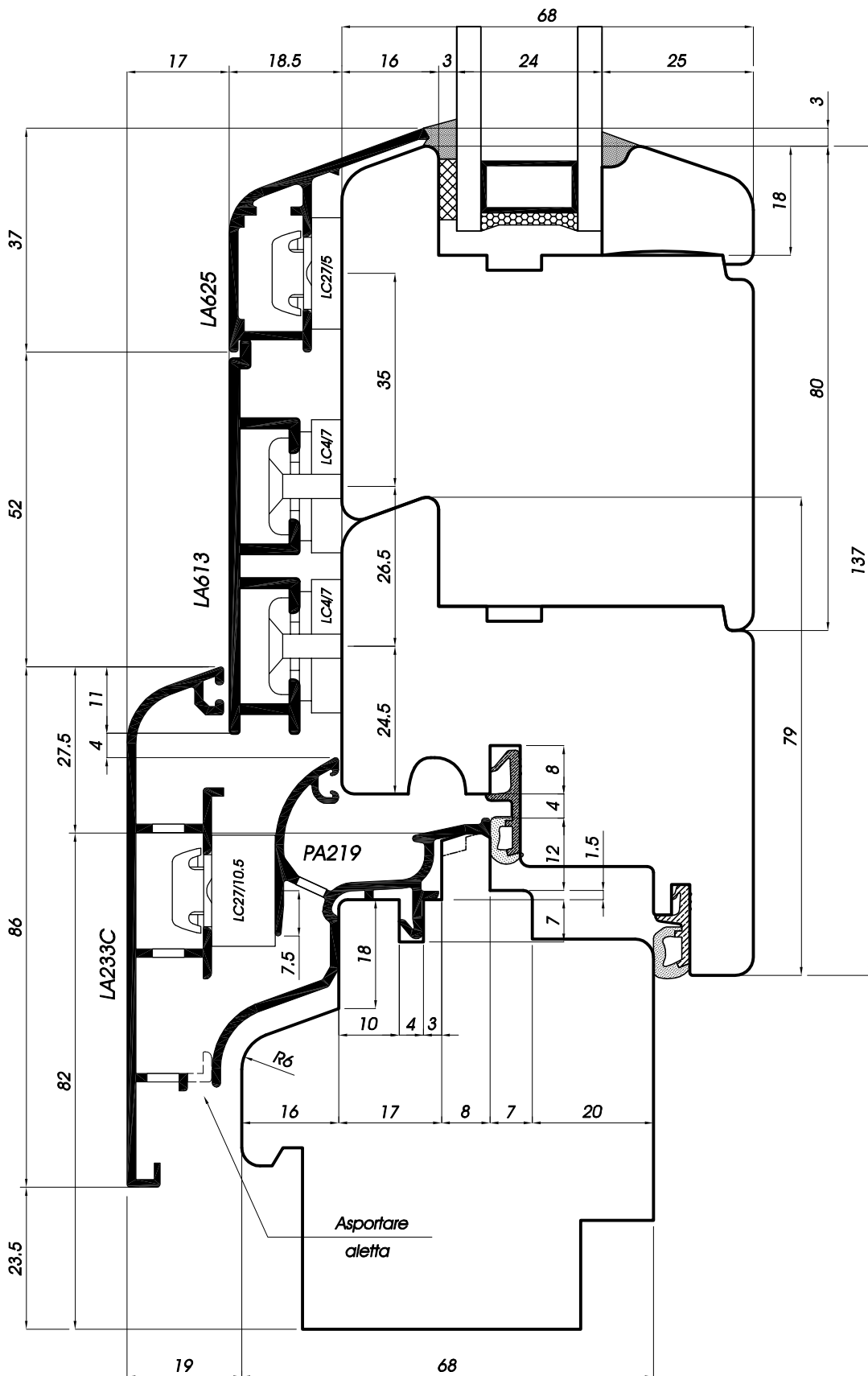

**Sezione verticale traverso inferiore portafinestra**  
**Vertikalschnitt Balkontür unten quer**  
**Sección vertical travesaño inferior puertaventana**  
**Coupe verticale traverse inférieure porte-fenêtre**  
**Vertical section of the window-door's middle ledger**

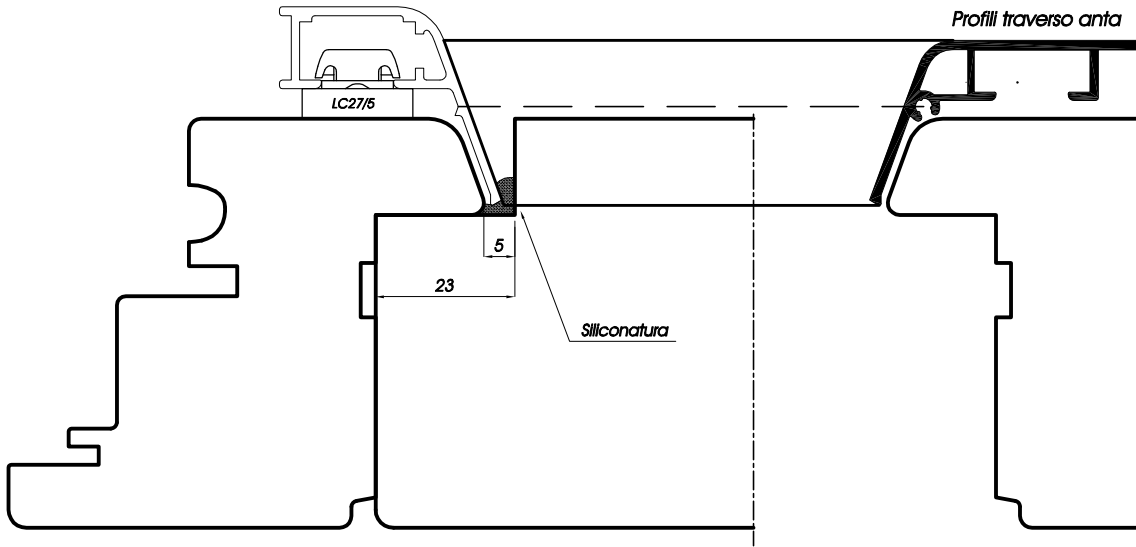

**INTESTATURA DEI TRAVERSI AGGIUNTI**

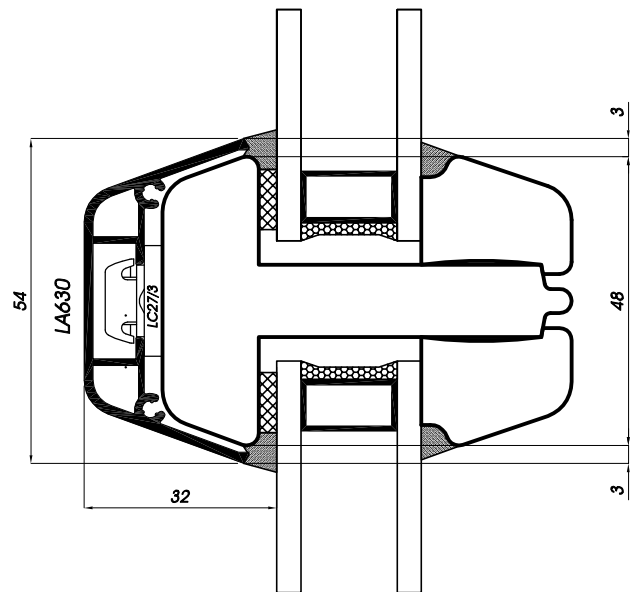
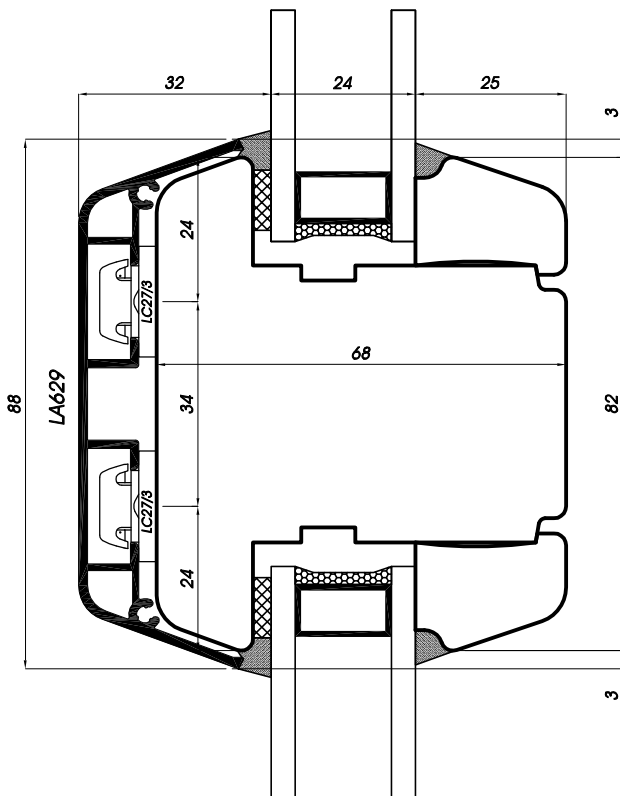

*Sezione verticale traversi intermedi anta*  
*Vertikalschnitt Flügelsprossen*  
*Sección vertical travesaños intermedios hojas*  
*Coupe verticale des traverses intermédiaires du vantail*  
*Vertical section of the wing's middle ledgers*



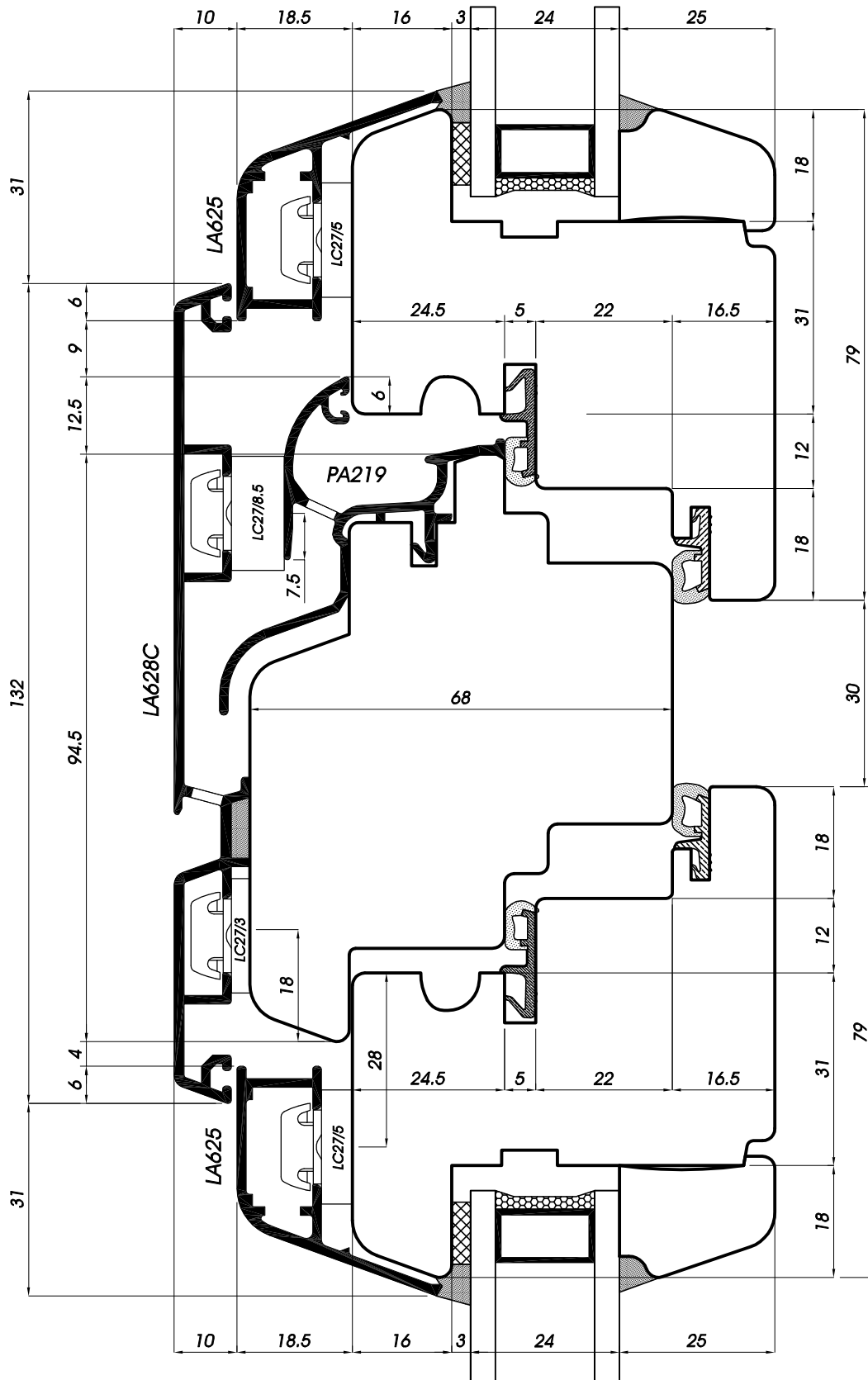

Sezione verticale traverso intermedio telaio  
 Vertikalschnitt Rahmensprossen  
 Sección vertical travesaño intermedio del marco  
 Coupe verticale de la traverse intermédiaire du dormant  
 Vertical section of the frame's middle ledger

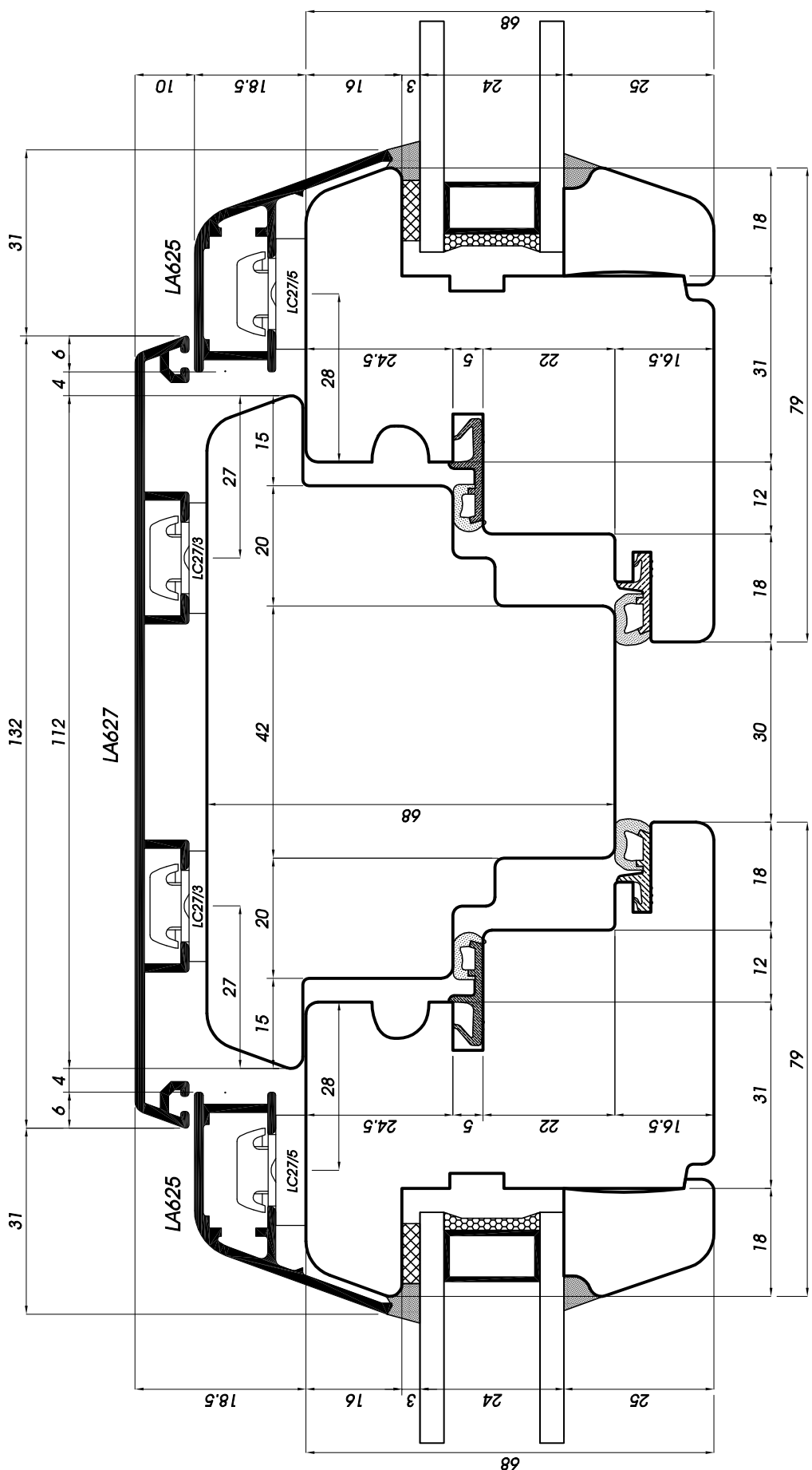

Sezione orizzontale montante intermedio telaio  
 Horizontalschnitt Setzholz Rahmen  
 Sección horizontal montante intermedio del marco  
 Coupe horizontale montant intermédiaire dormant  
 Horizontal section of the frame's middle jamb

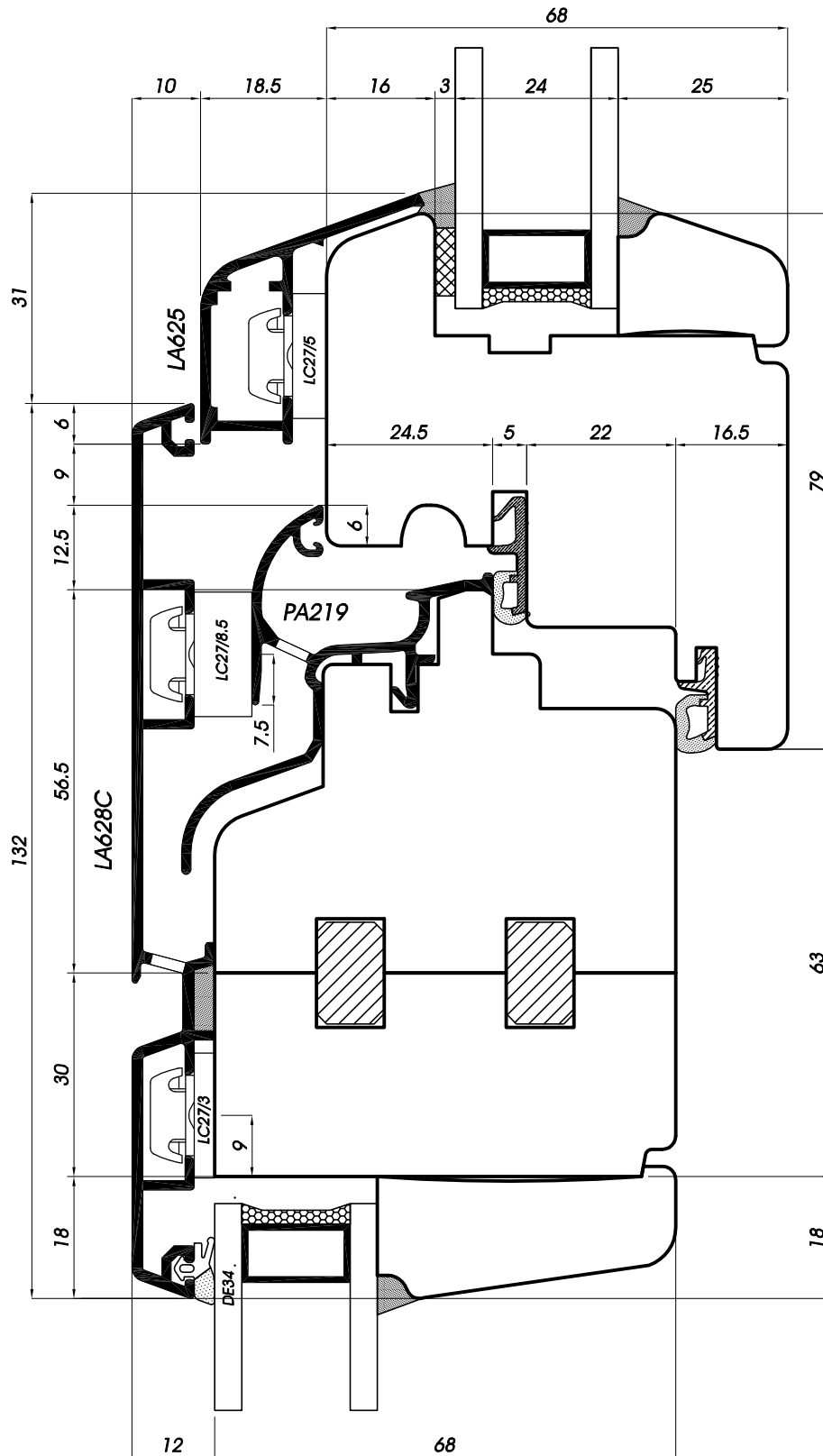

Sezione verticale traverso intermedio telaio con sottoluce fisso  
 Vertikalschnitt Rahmensprossen mit Unterlicht Fixverglasung  
 Sección vertical travesaño intermedio del marco con antepecho fijo  
 Coupe verticale traverse intermédiaire du dormant avec imposte en partie inférieure  
 Vertical section of the frame's middle ledger with under fixed frame

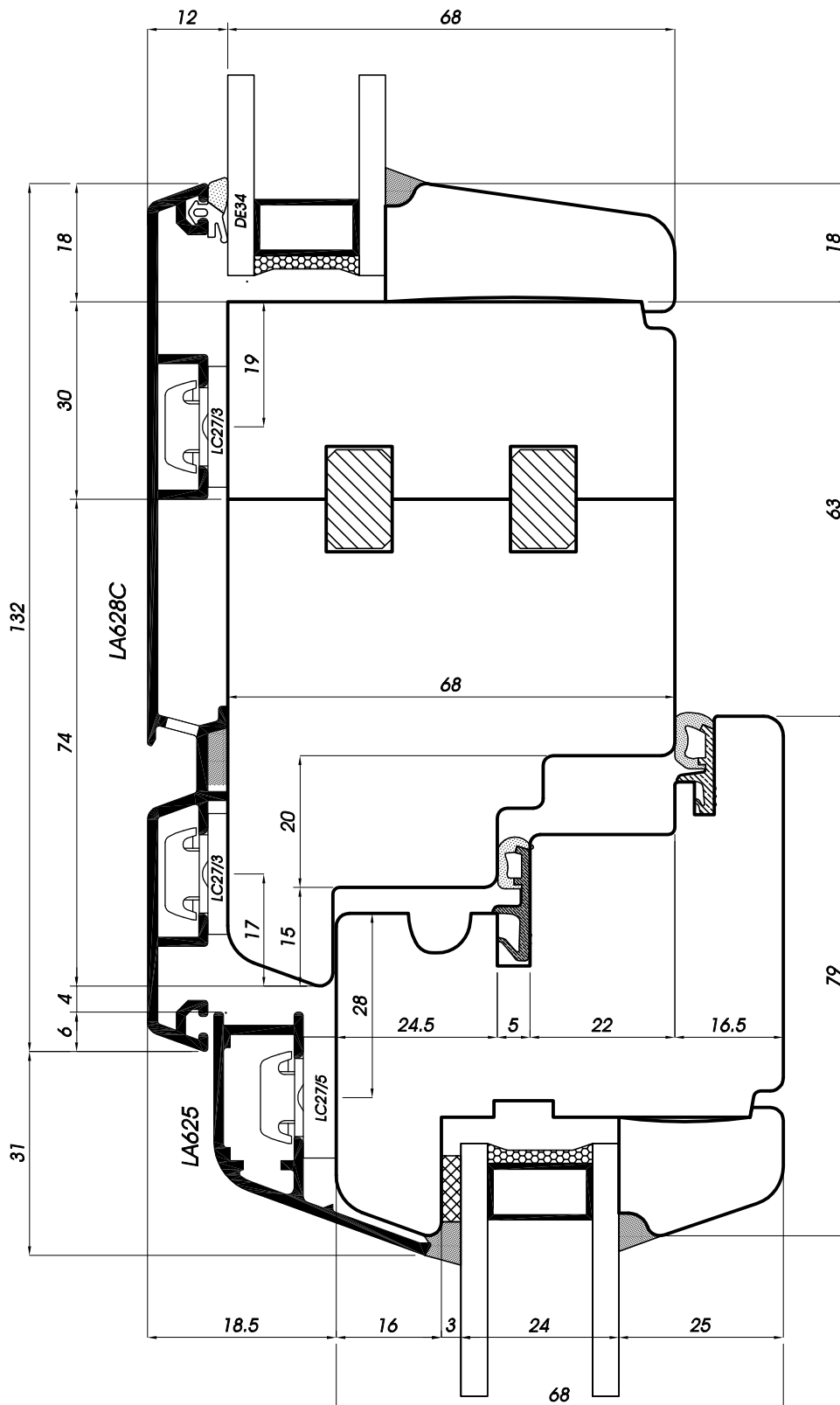

**Sezione verticale traverso intermedio telaio con sopra luce fisso**  
**Vertikalschnitt Rahmensprossen mit Oberlicht Fixverglasung**  
**Sección vertical travesaño intermedio del marco con sobreluz fijo**  
**Coupe horizontale montant intermédiaire dormant avec vitre fixe**  
**Vertical section of the frame's middle ledger with under fixed frame**

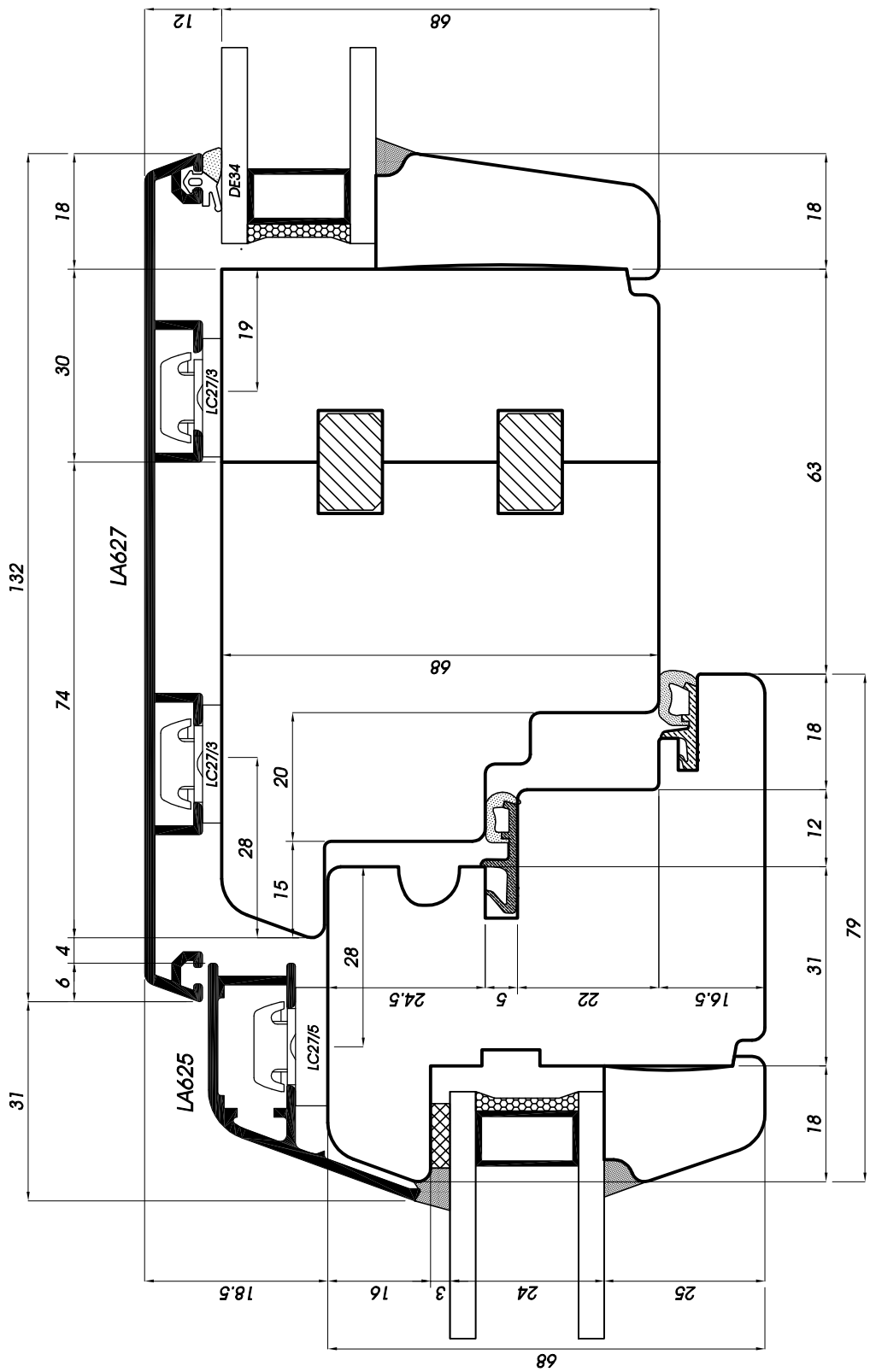

Sezione orizzontale montante intermedio telaio con vetro fisso  
 Horizontalschnitt Setzholz Rahmen mit Fixverglasung  
 Sección horizontal montante intermedio del marco con cristal fijo  
 Coupe horizontale montant intermédiaire dormant avec vitre fixe  
 Horizontal section of the frame's middle jamb with fixed glass

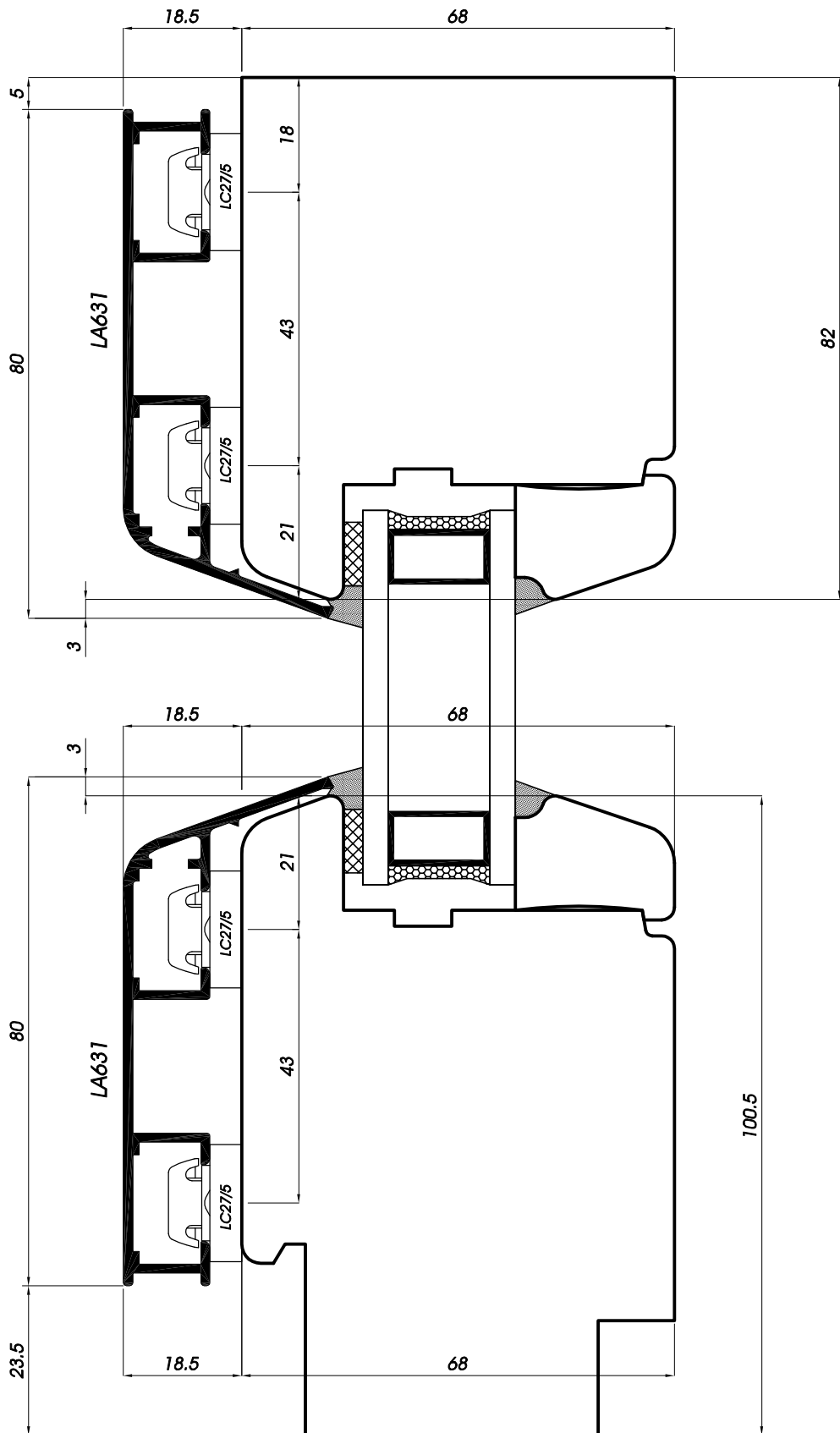

**Sezione verticale finestra con vetro fisso**  
**Vertikalschnitt Fenster Fixverglasung**  
**Sección vertical ventana con cristal fijo**  
**Coupe verticale fenêtre avec vitre fixe**  
**Vertical window's section with fixed glass**

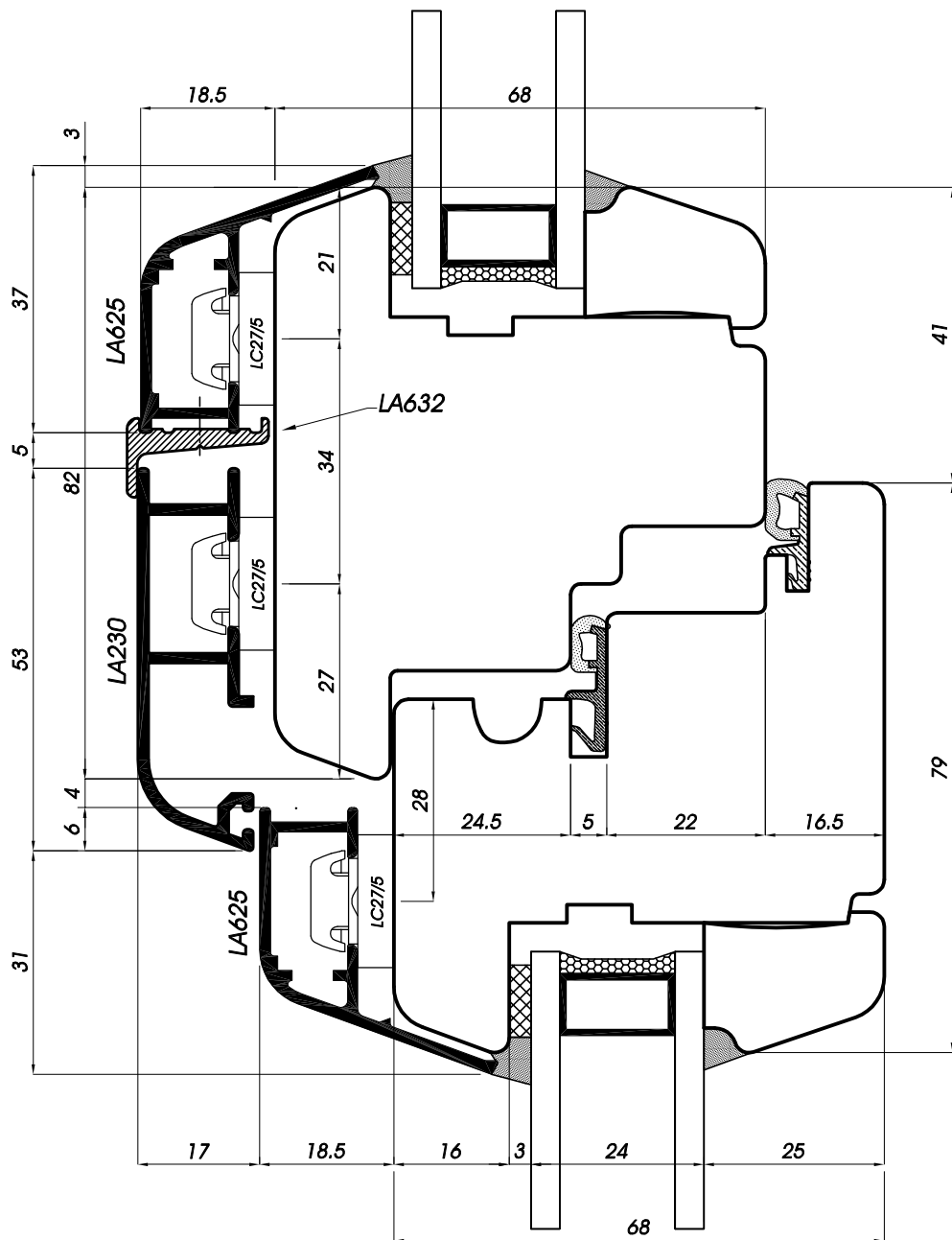

**Sezione verticale traverso intermedio telaio con sopra luce fisso**  
**Vertikalschnitt Rahmensprossen mit Oberlicht Fixverglasung**  
**Sección vertical travesaño intermedio del marco con sobreluz fijo**  
**Coupe verticale traverse intermédiaire du dormant avec imposte en partie supérieur**  
**Vertical section of the frame's middle jamb with under fixed frame**

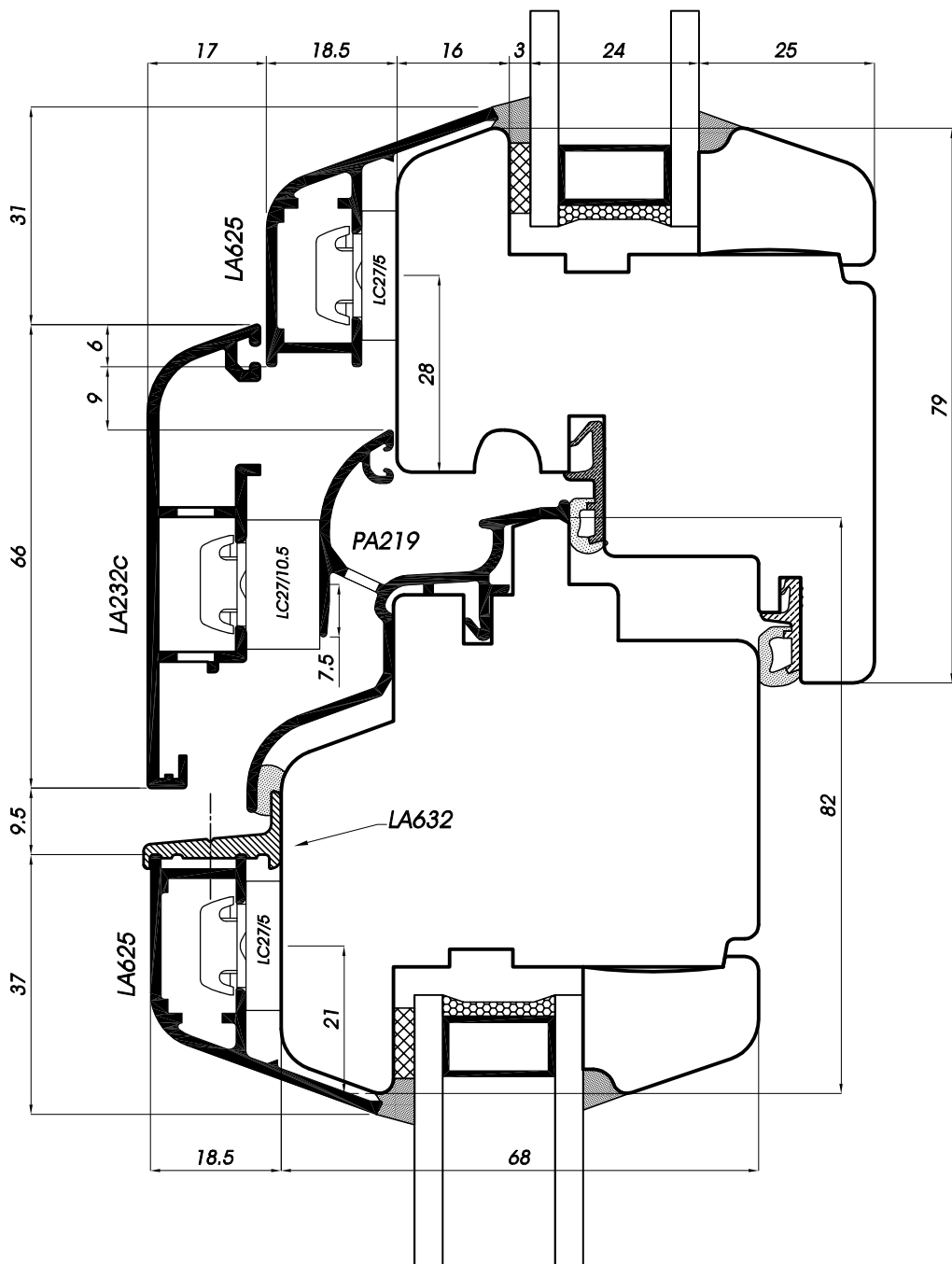

Sezione verticale traverso intermedio telaio con sottoluce fisso  
 Vertikalschnitt Rahmensprossen mit Unterlicht Fixverglasung  
 Sección vertical travesaño intermedio del marco con antepecho fijo  
 Coupe verticale traverse intermédiaire du dormant avec imposte en partie inférieur  
 Vertical section of the frame's middle jamb with under fixed frame



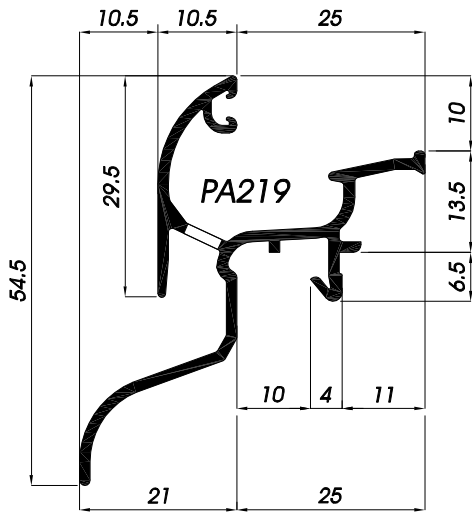

con terminali PT219

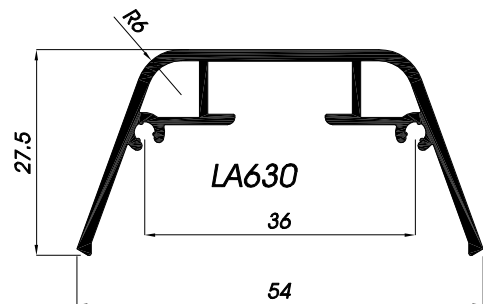
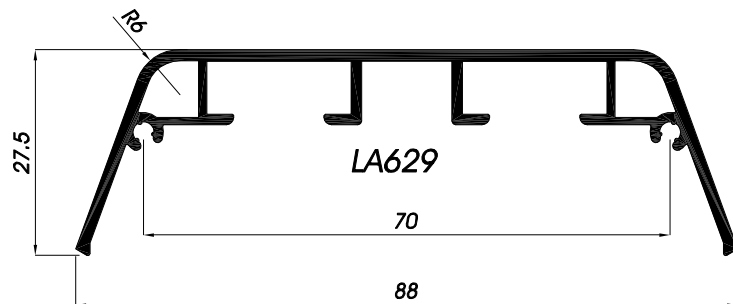
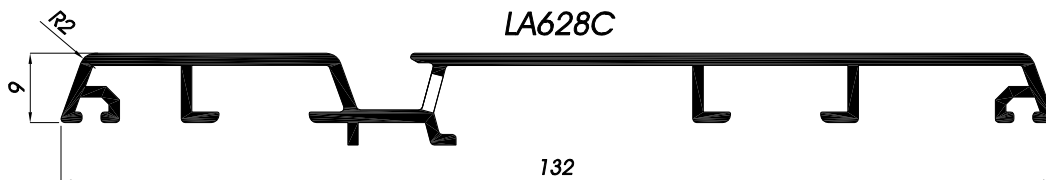
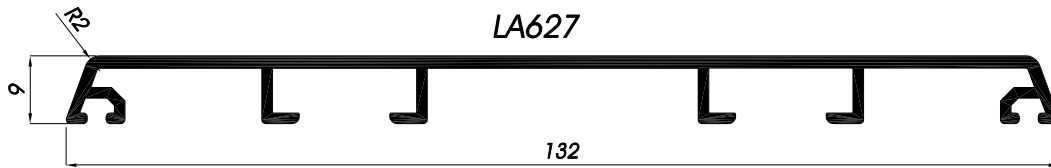
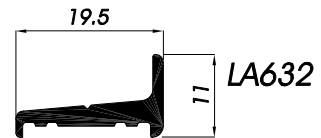
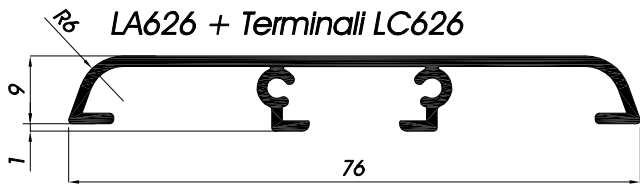
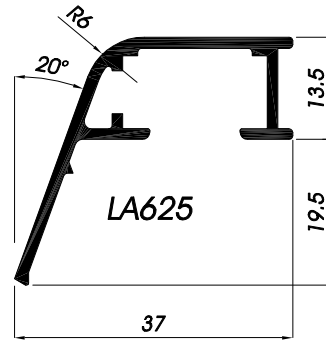
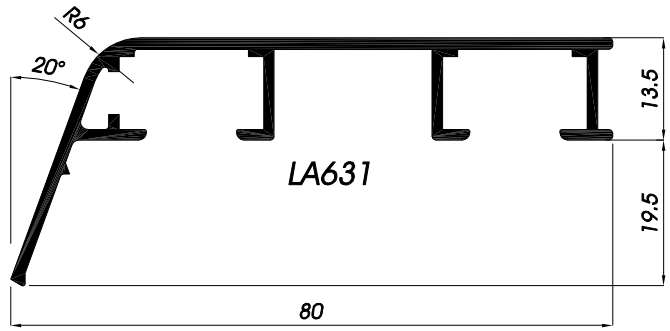

Profili in alluminio  
 Aluminiumprofile  
 Perfiles de aluminio  
 Profils en aluminium  
 Aluminium profiles

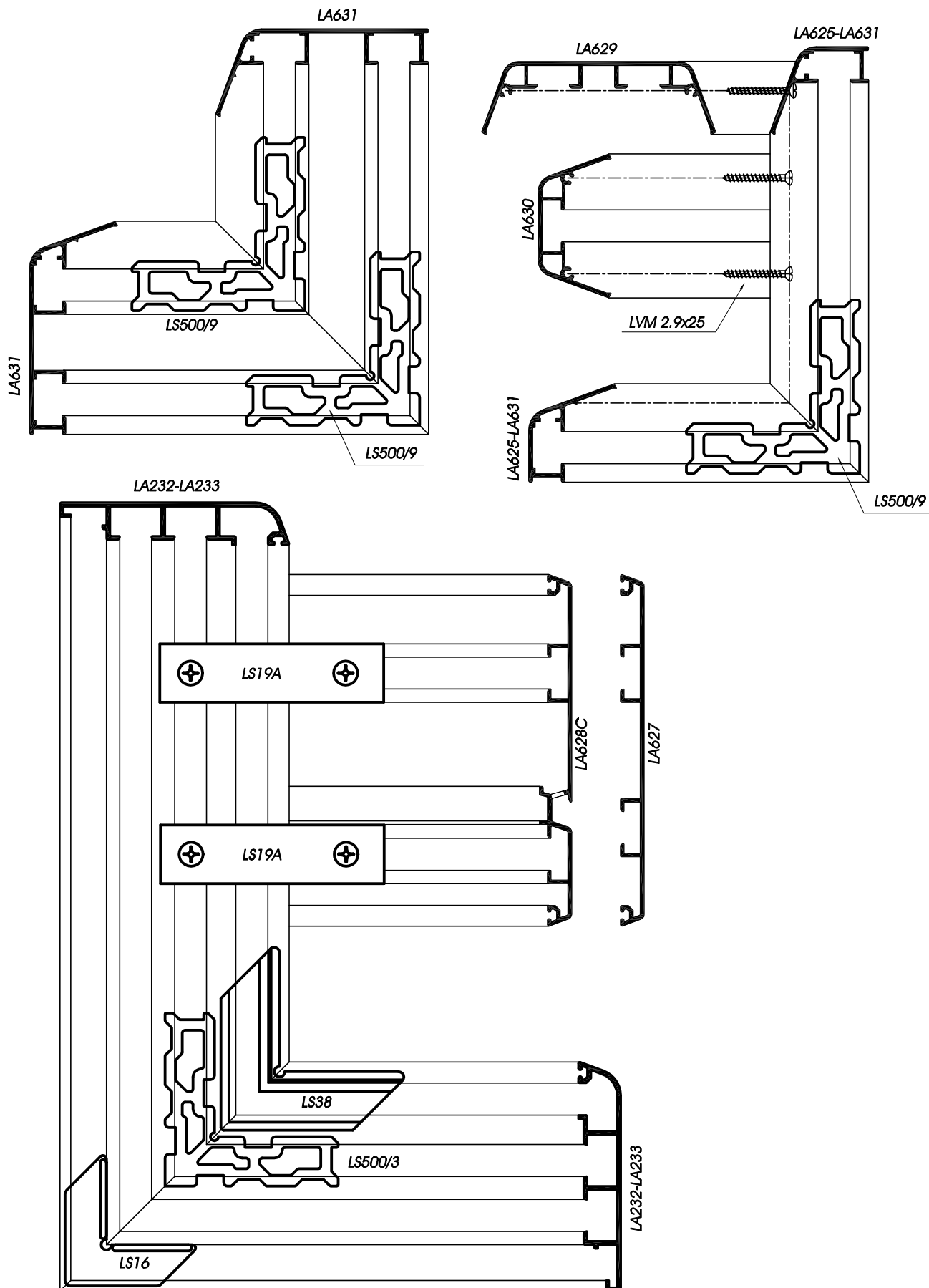

**Squadrette per profili anta e profili telaio**  
**Eckwinkel für Flügelprofile und Rahmenprofile**  
**Escuadras para perfiles de hoja y del marco**  
**Equerres pour profils vantaux et profils dormant**  
**Corner spigot for the wing's and frame's profiles**

**DIMENSIONI MASSIME CONSIGLIATE sp. 45mm**

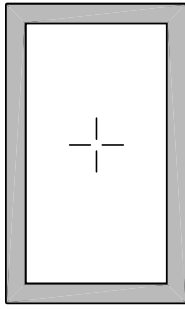

**FISSO**  
L= 400-2200mm  
H= 400-2200mm

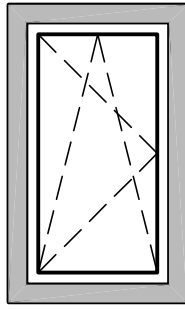

**Fin. 1 ante**  
L= 410-1200mm  
H= 485-1800mm

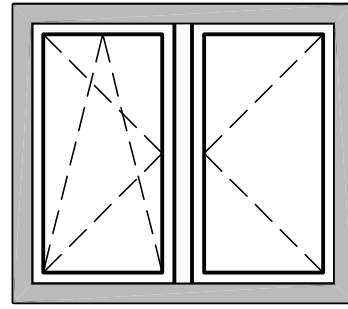

**Fin. 2 ante**  
L= 750-1800mm  
H= 600-1800mm

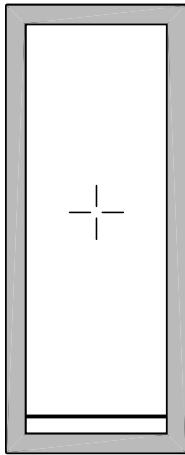

**FISSO-Porta**  
L= 400-2200mm  
H= 800-2450mm

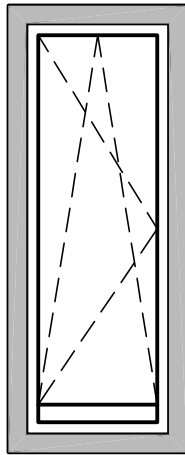

**PFin. 1 ante**  
L= 500-1100mm  
H= 1800-2450mm

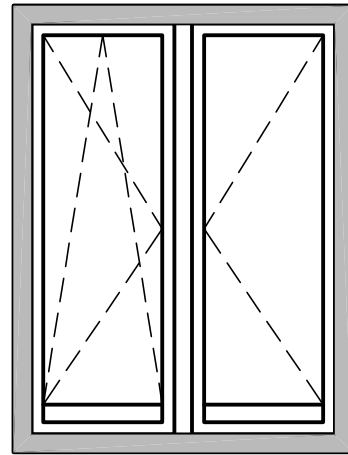

**PFin. 2 ante**  
L= 900-1800mm  
H= 1800-2450mm

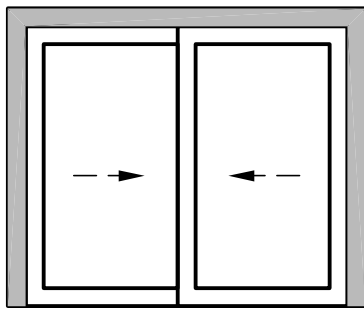

**Fin. Scorrevole**  
L= 1300-2800mm  
H= 800-1800mm

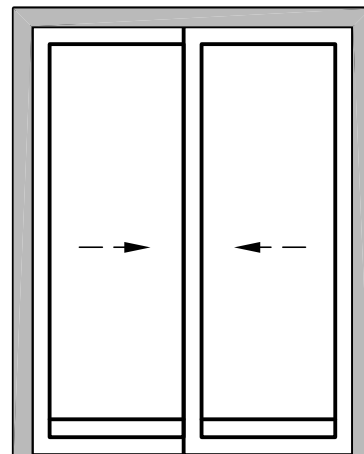

**PFin. Scorrevole**  
L= 1300-2800mm  
H= 1800-2450mm

**Limiti dimensionali su spessore legno 45mm**  
**Maßliche Begrenzung bei Holzstärke 45mm**  
**Límites dimensionales por el espesor de madera de 45 mms.**  
**Dimensions limites pour épaisseur bois 45 mm**  
**Dimensional limits over the wood-thickness of 45 millimeter**

# Sistema

1000/45 \_ SOFT/45 \_ Verbund/45

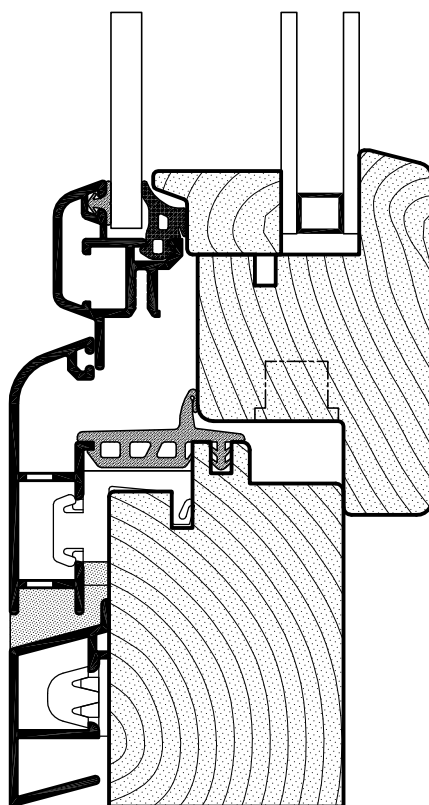
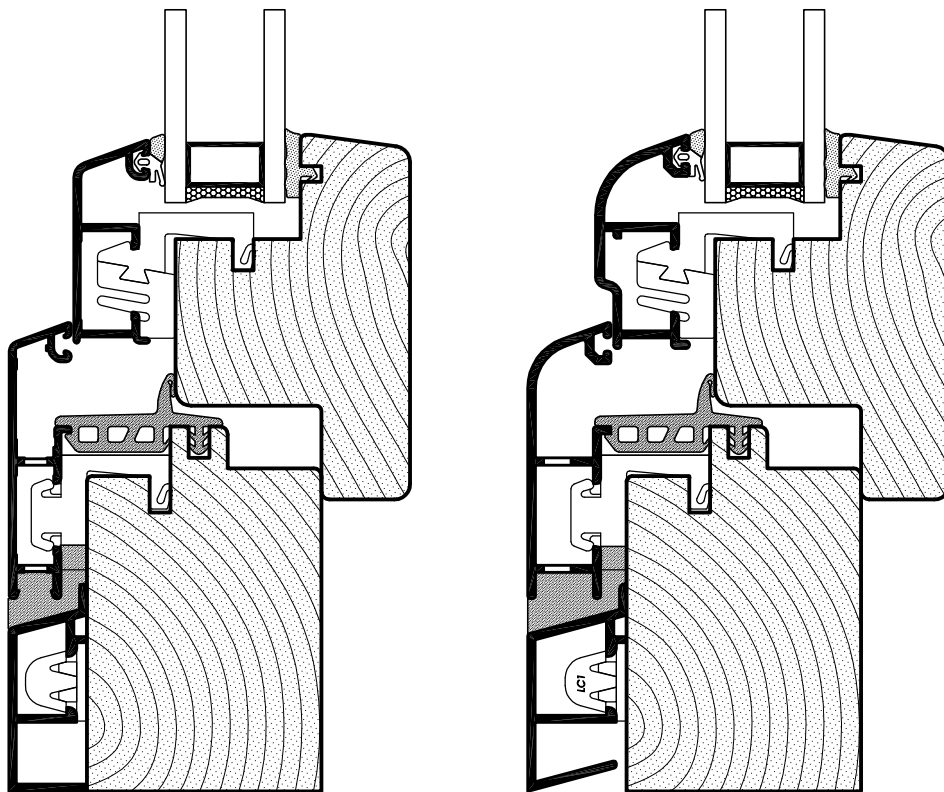

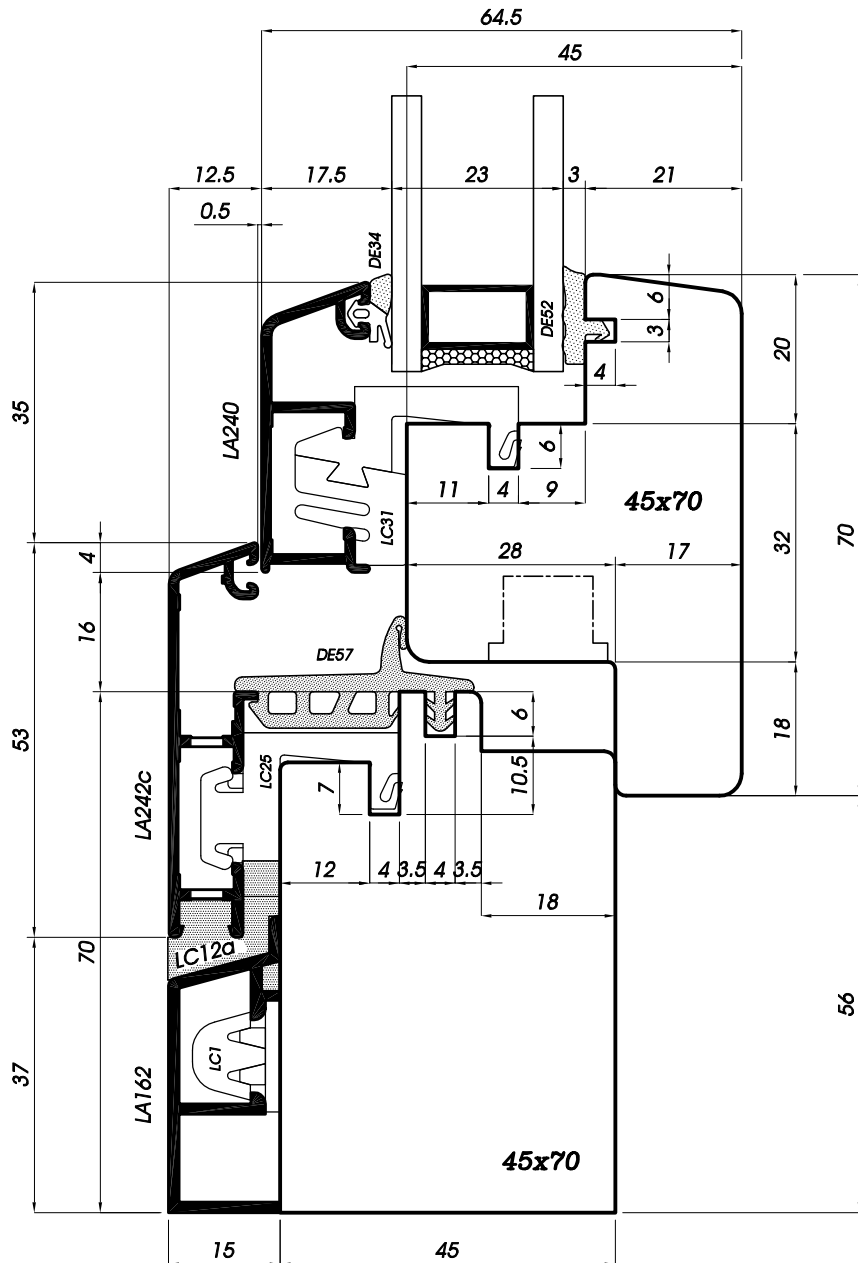
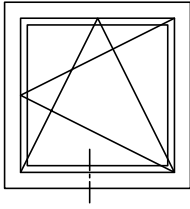

Sezione verticale traverso inferiore finestra  
 Vertikalschnitt Fenster quer unten  
 Sección vertical travesaño inferior de la ventana  
 Coupe verticale traverse inférieure fenêtré  
 Vertical section of the window's lower ledger

Terminali LC319/45

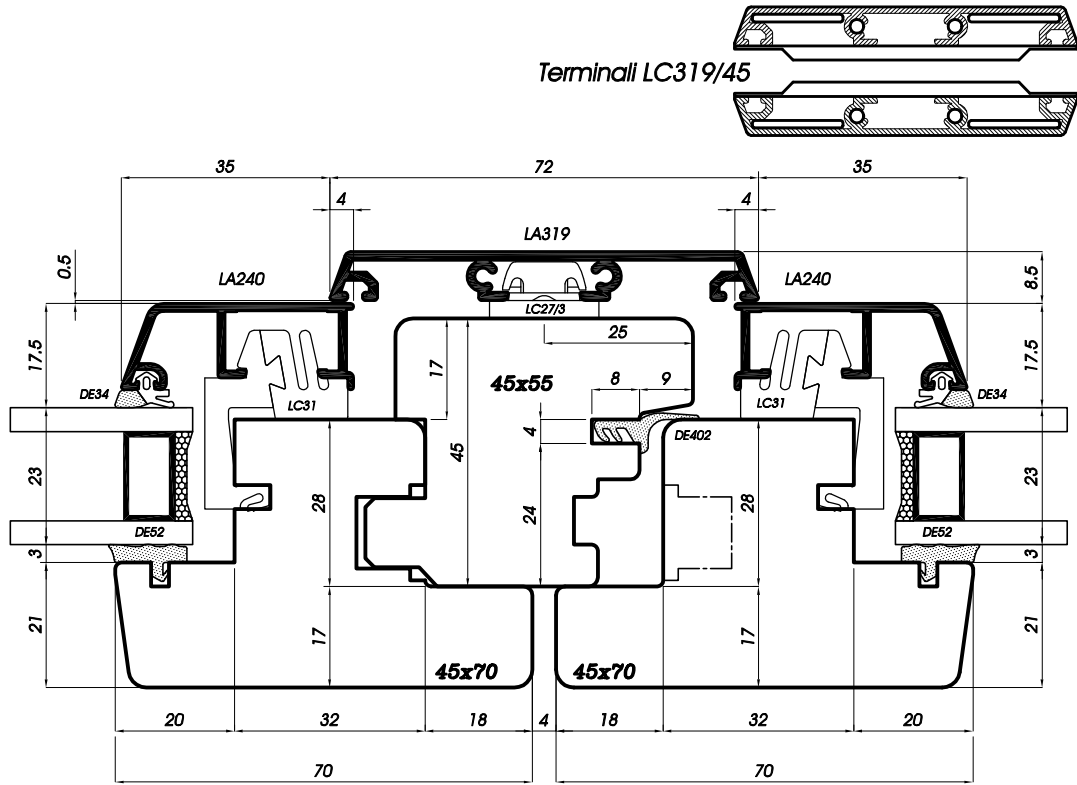

Terminali LC264

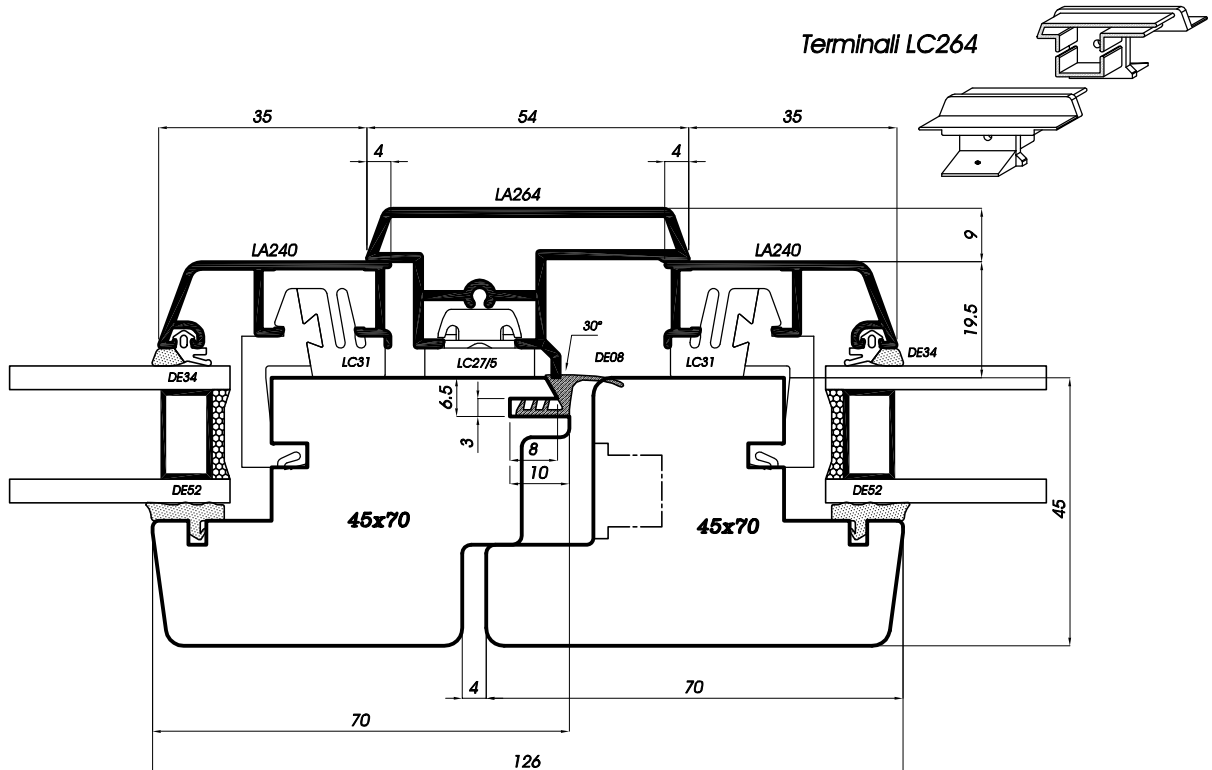

Sezione orizzontale chiusura centrale con profili LA319-LA264  
 Horizontalschnitt Stulprofil LA319-LA264  
 Sección horizontal del cierre central con perfiles LA319-LA268  
 Coupe horizontale battement central avec profil LA319 - LA264  
 Horizontal section of the middle clamp with profiles LA319-LA264

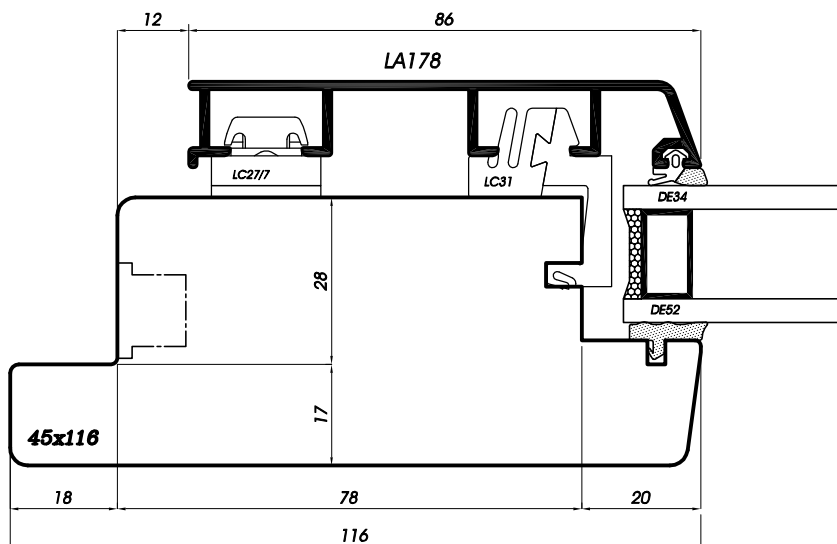
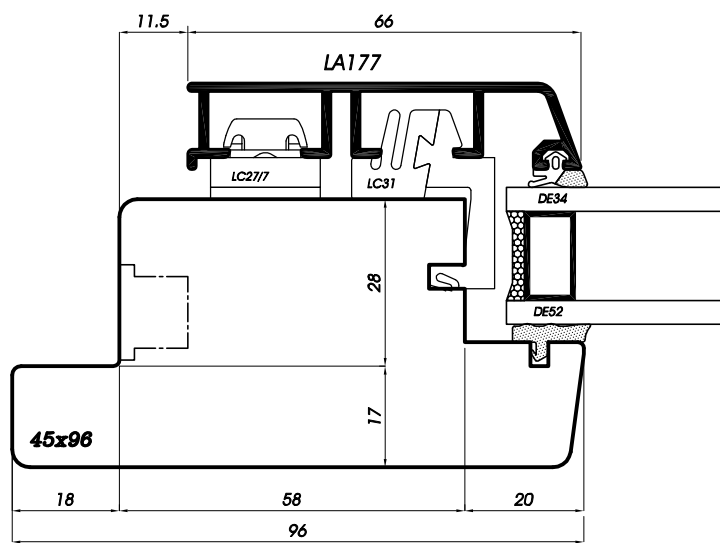
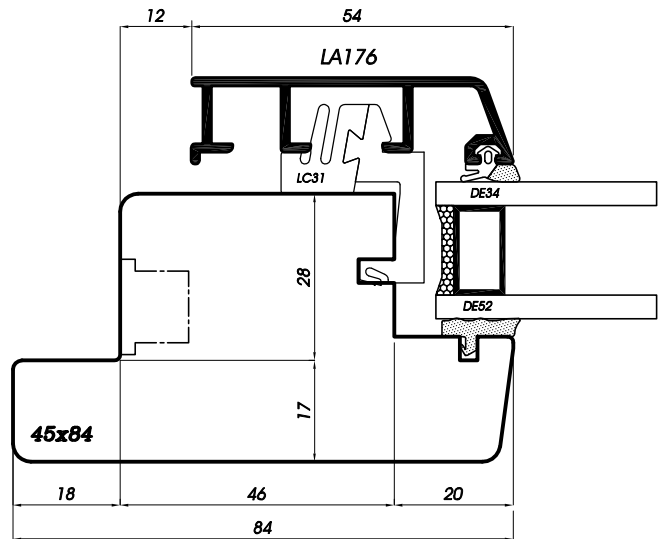
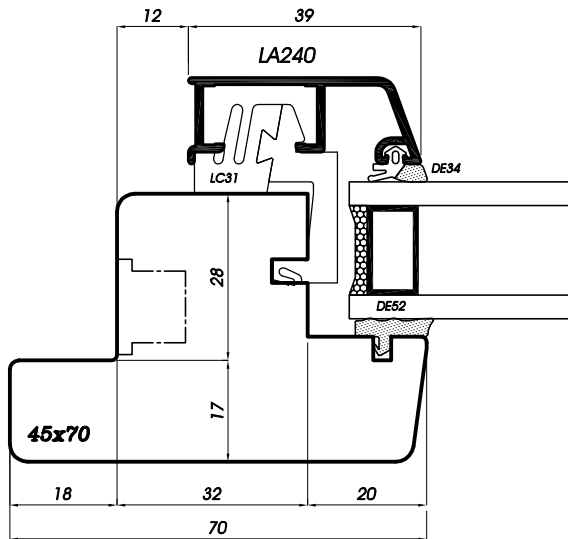

**Sezioni orizzontali battenti**  
**Horizontalschnitt Flügel**  
**Secciones horizontales hojas**  
**Coupes horizontales vantaux**  
**Horizontal wings' section**

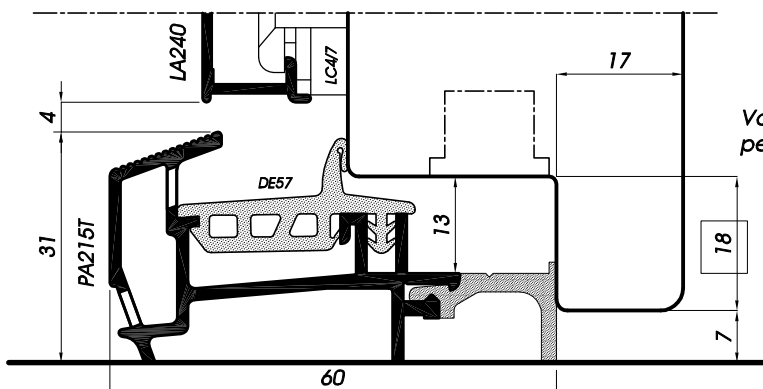
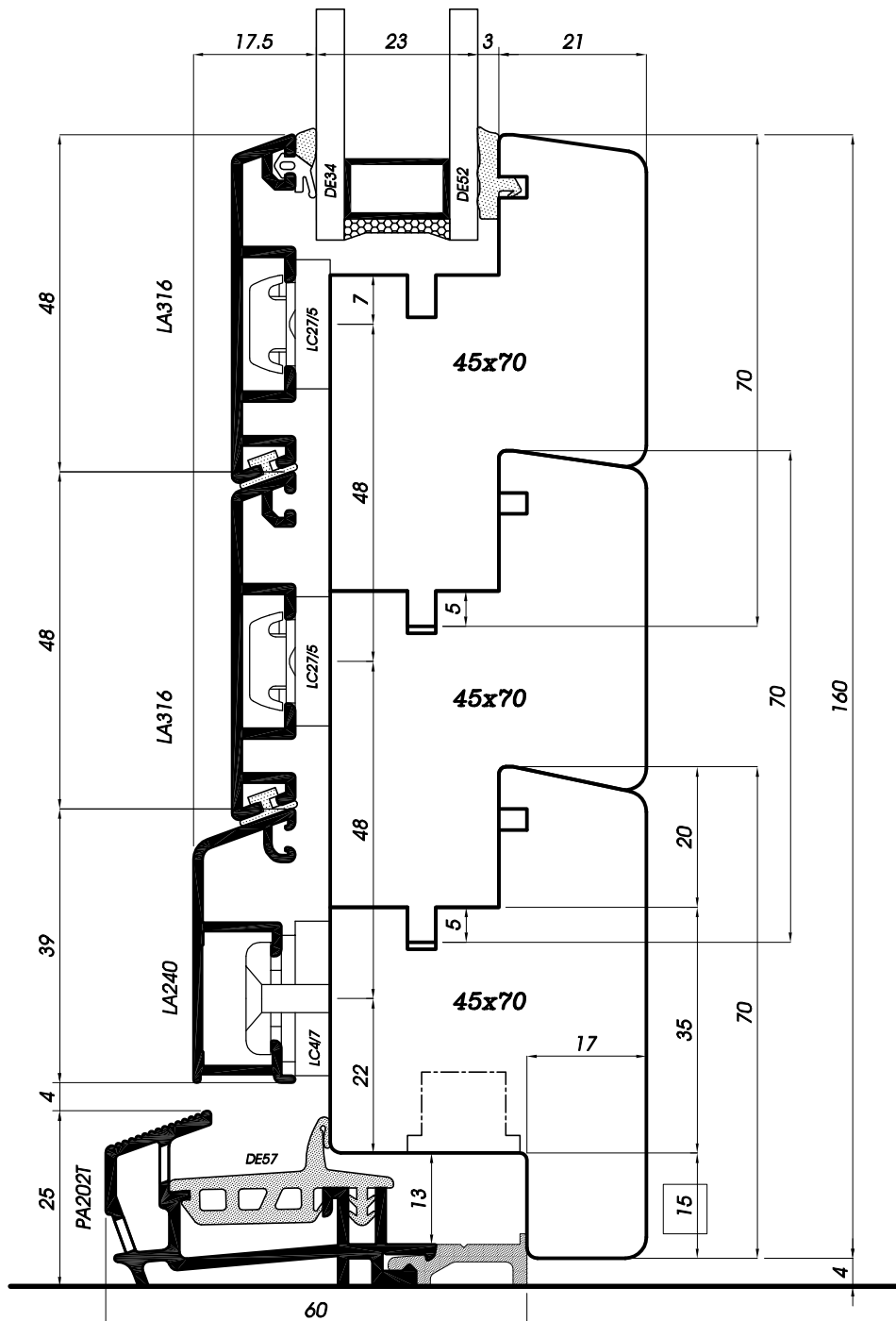

Variante con soglia PA215T  
per battuta anta 18mm

Sezione verticale traverso inferiore portafinestra  
Vertikalschnitt Balkontür quer unten  
Sección vertical travesaño inferior puertaventana  
Coupe verticale traverse inférieure porte-fenêtre  
Vertical section of the window-door lower ledger



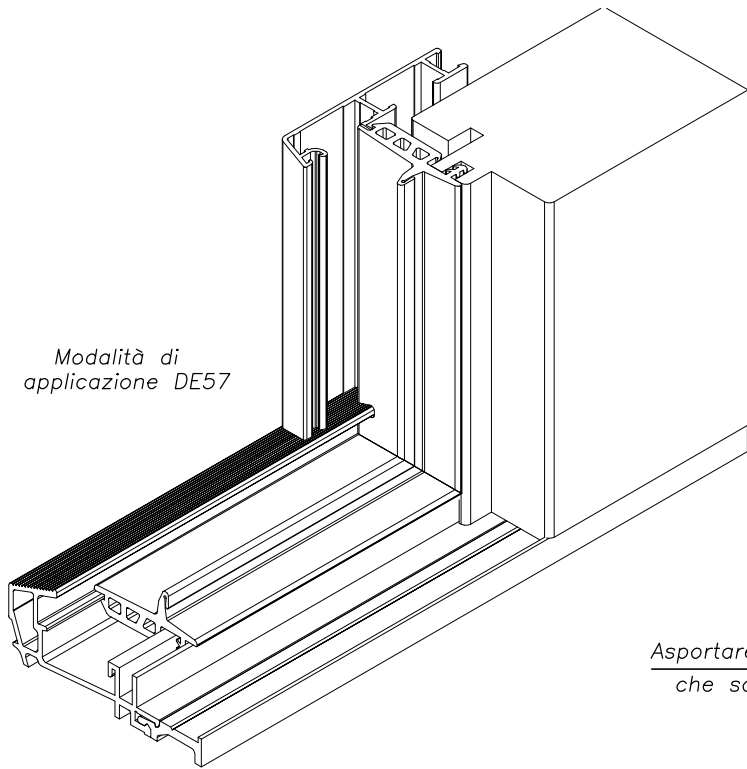

Modalità di applicazione DE57

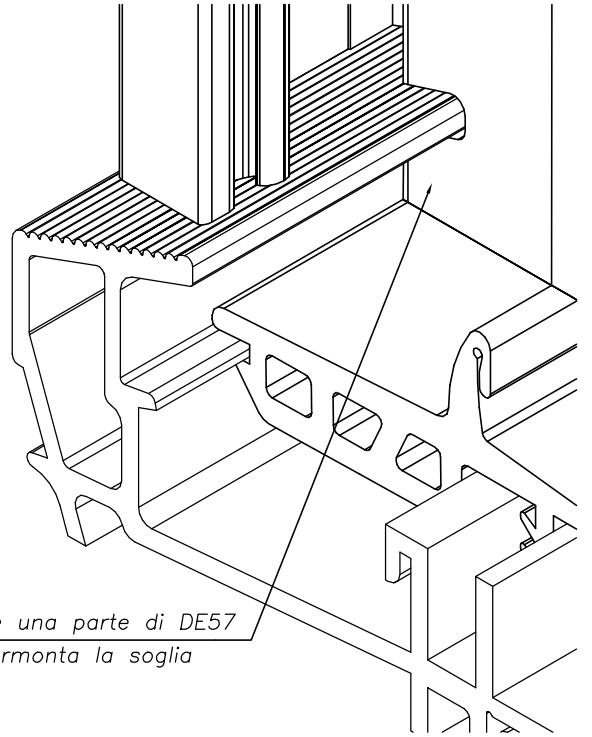

Asportare una parte di DE57 che sormonta la soglia

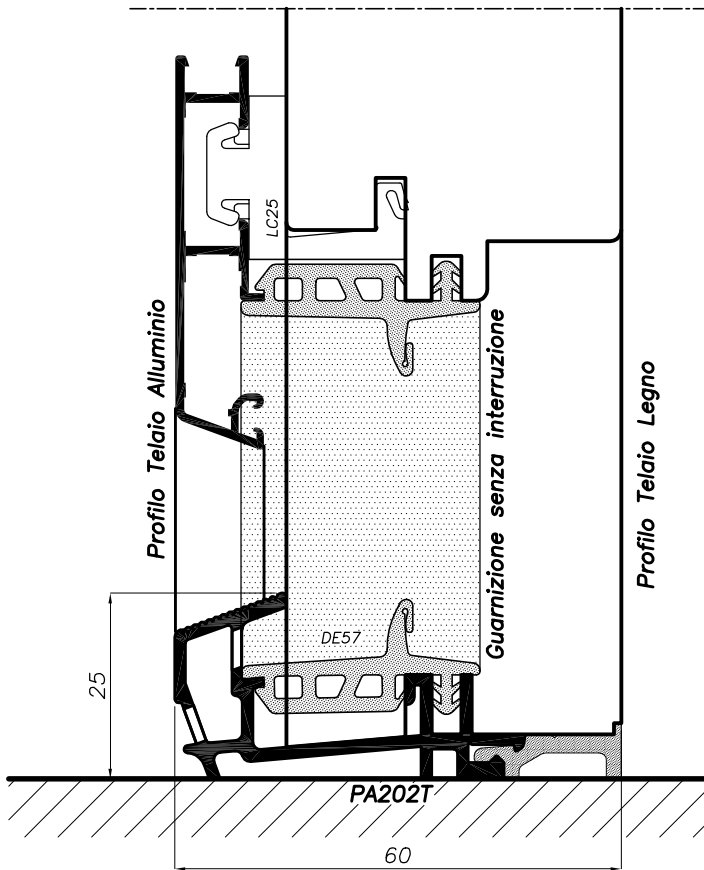

### Vantaggi PA202T

- Guarnizione DE57 continua
- Taglio termico
- Ferramenta Anti-Effrazione
- Zigrinatura antiscivolo



Terminali PT202

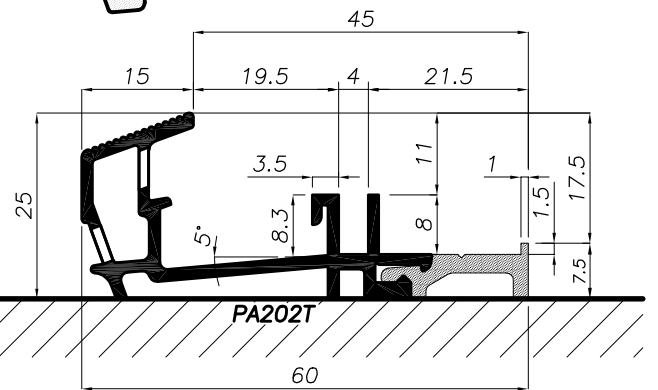

### Soglia per sistema 1000/45

Soglia per sistema 1000/45  
 Schwelle für System 1000/45  
 Umbral para sistema 1000/45  
 Seuil pour système 1000/45  
 Aluminium sill for system 1000/45

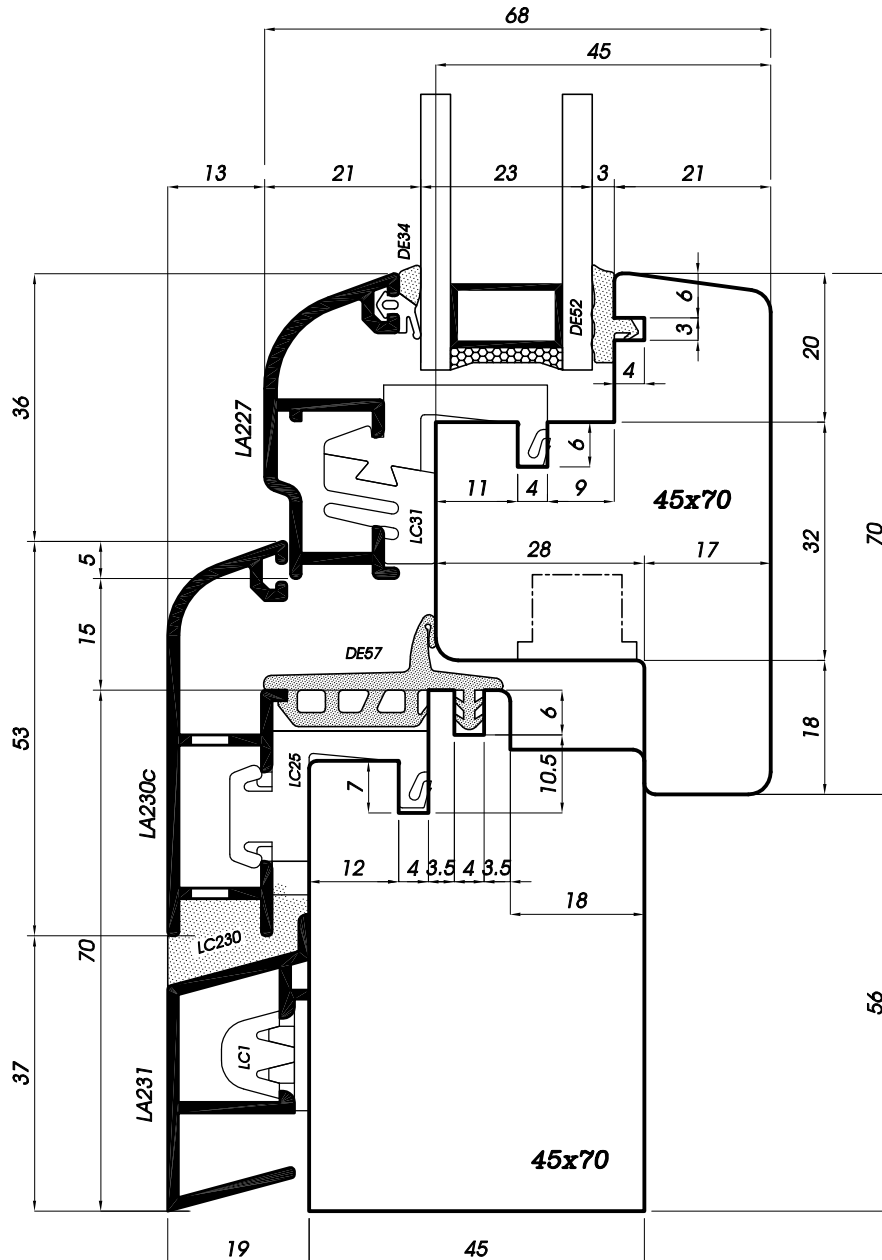
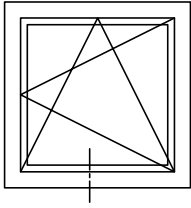

**Sezione verticale traverso inferiore finestra**  
**Vertikalschnitt Fenster quer unten**  
**Sección vertical travesaño inferior de la ventana**  
**Coupe verticale traverse inférieure fenêtre**  
**Vertical section of the window's lower ledger**

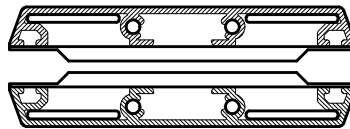

Terminali LC319/45

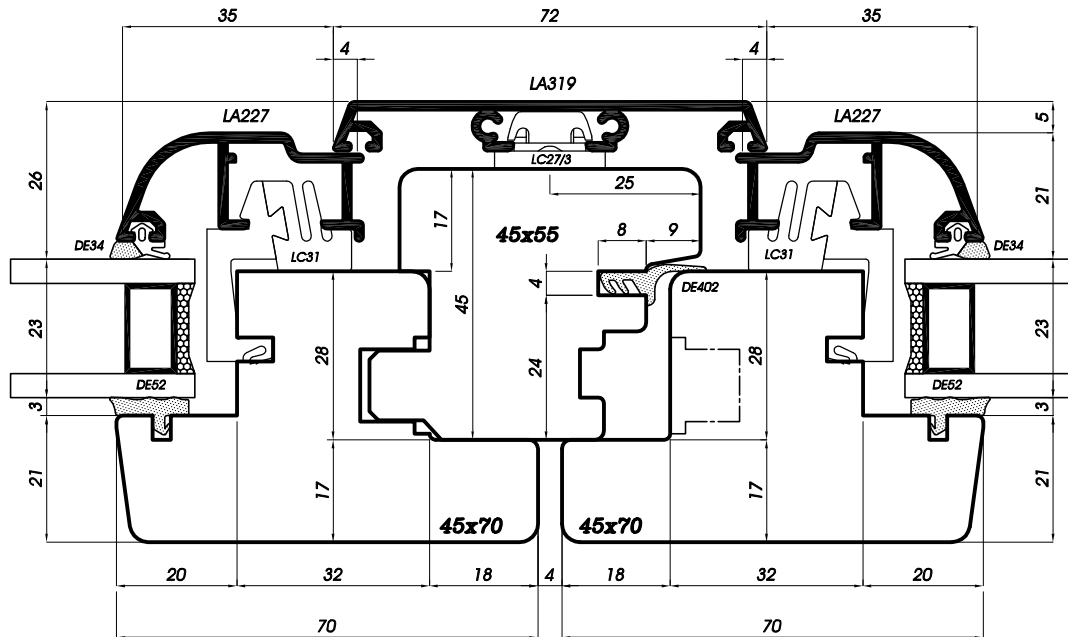

Terminali LC264

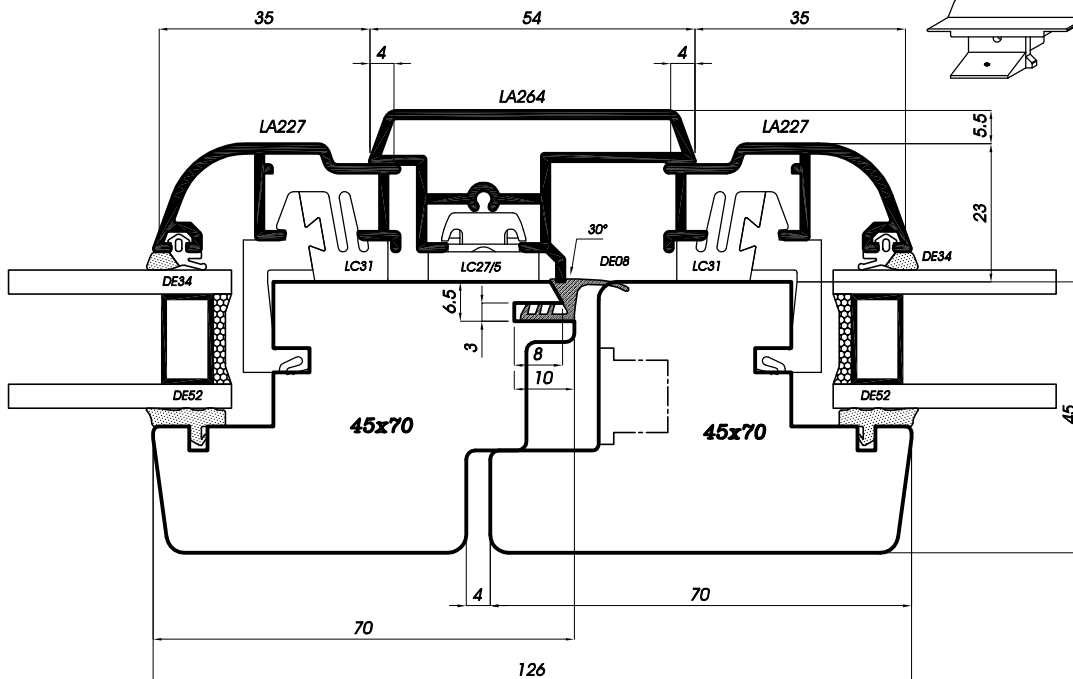
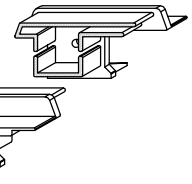

**Sezione orizzontale chiusura centrale con profili LA319-LA264**  
**Horizontalschnitt Stulprofil LA319-LA264**  
**Sección horizontal del cierre central con perfiles LA319-LA268**  
**Coupe horizontale battement central avec profil LA319 - LA264**  
**Horizontal section of the middle clamp with the profiles LA319-LA264**

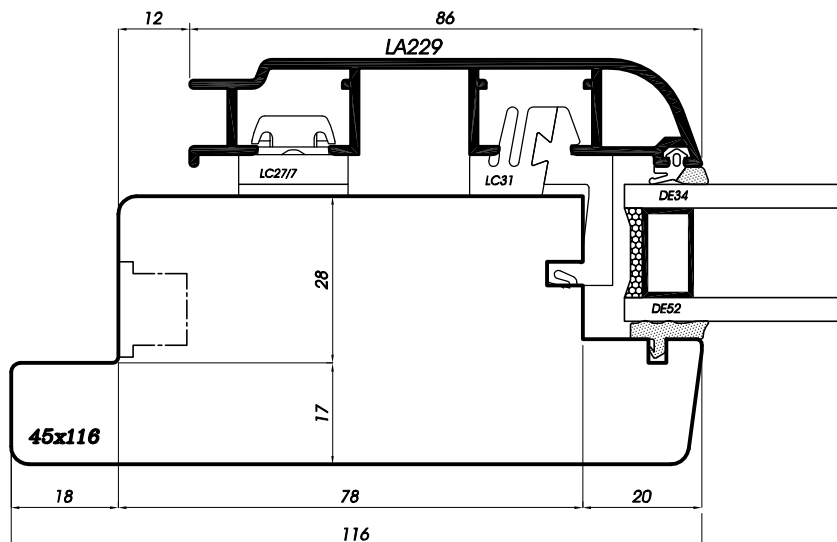
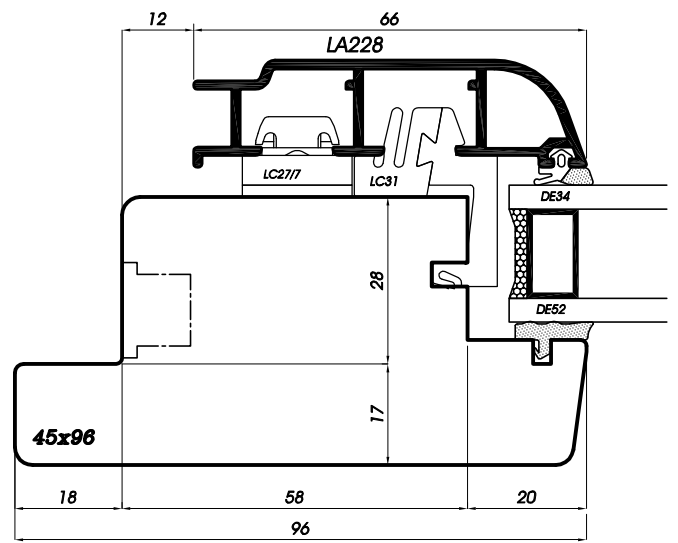
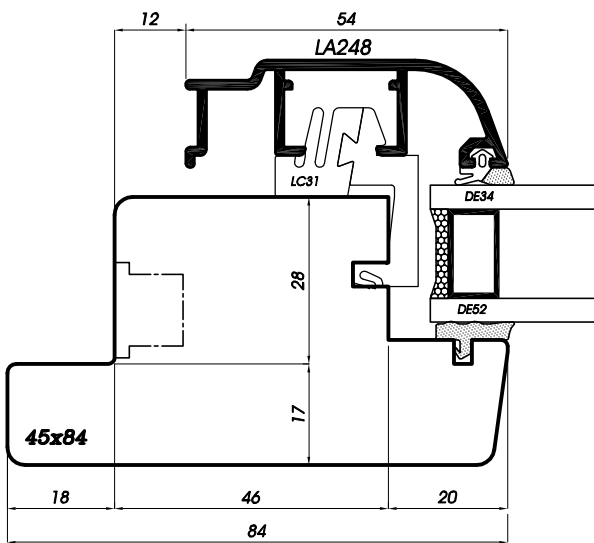
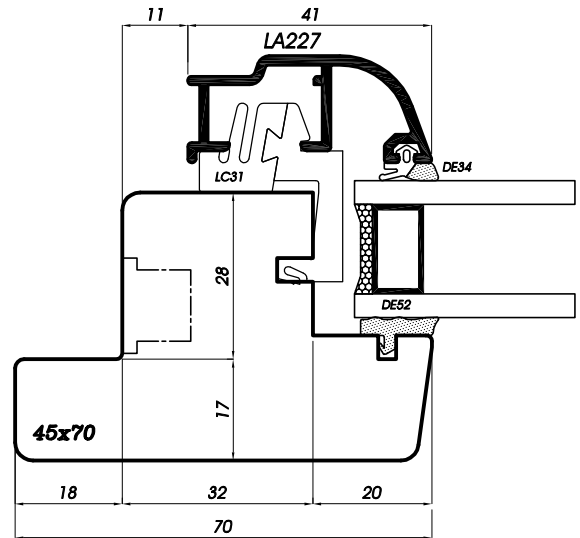
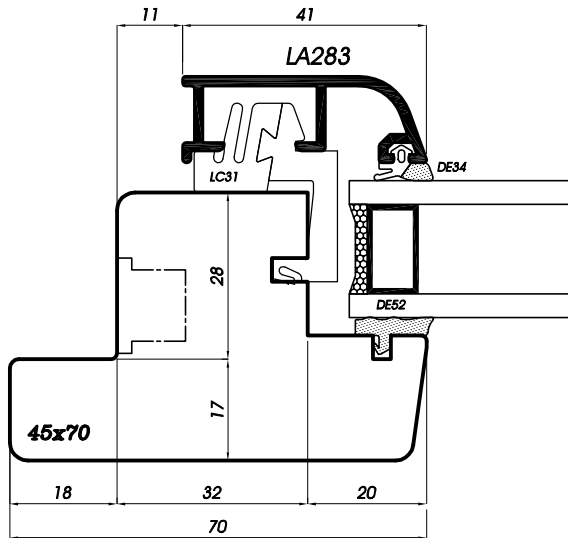

**Sezioni orizzontali battenti**  
**Horizontalschnitt Flügel**  
**Secciones horizontales hojas**  
**Coupes horizontales vantaux**  
**Horizontal wings'section**



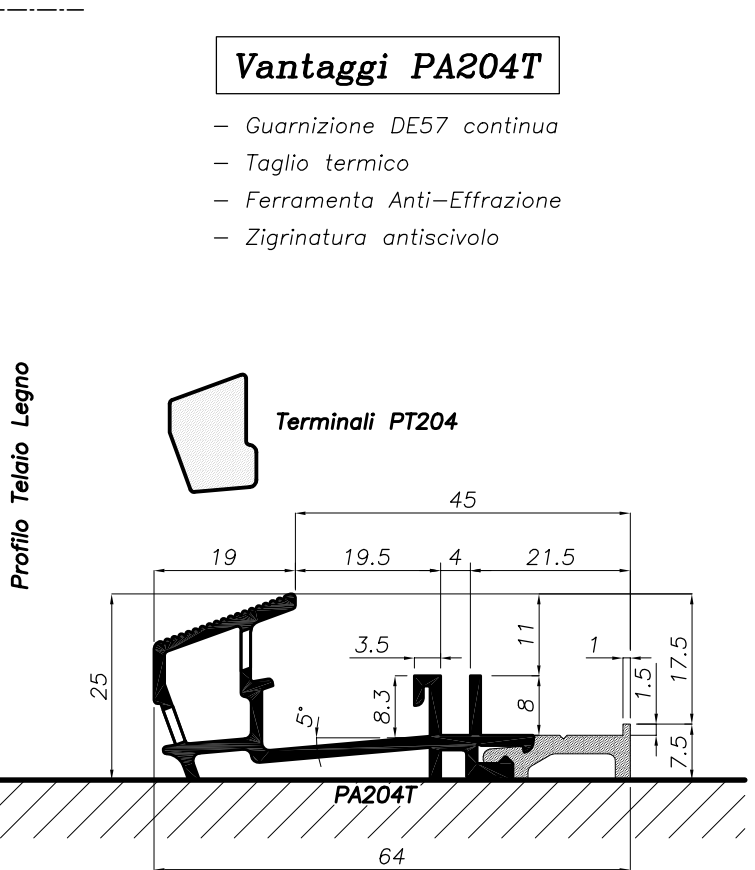
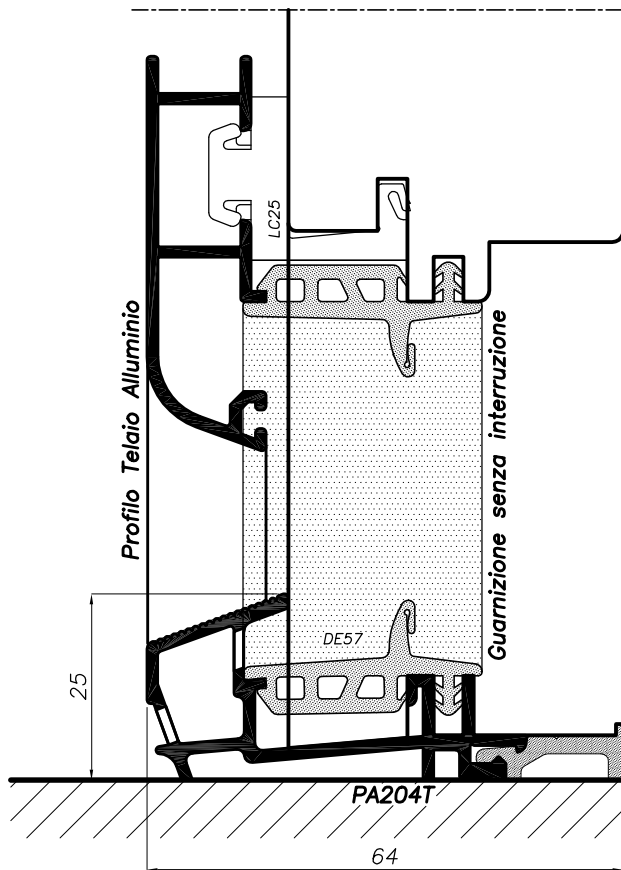
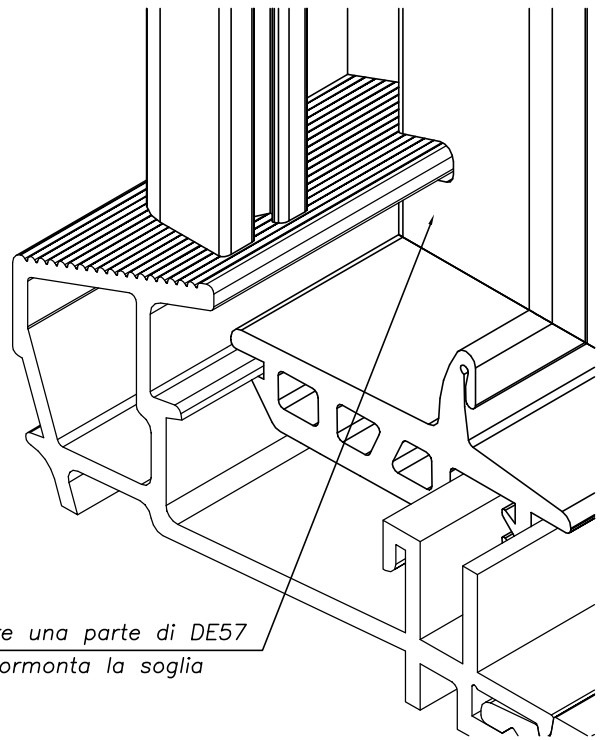
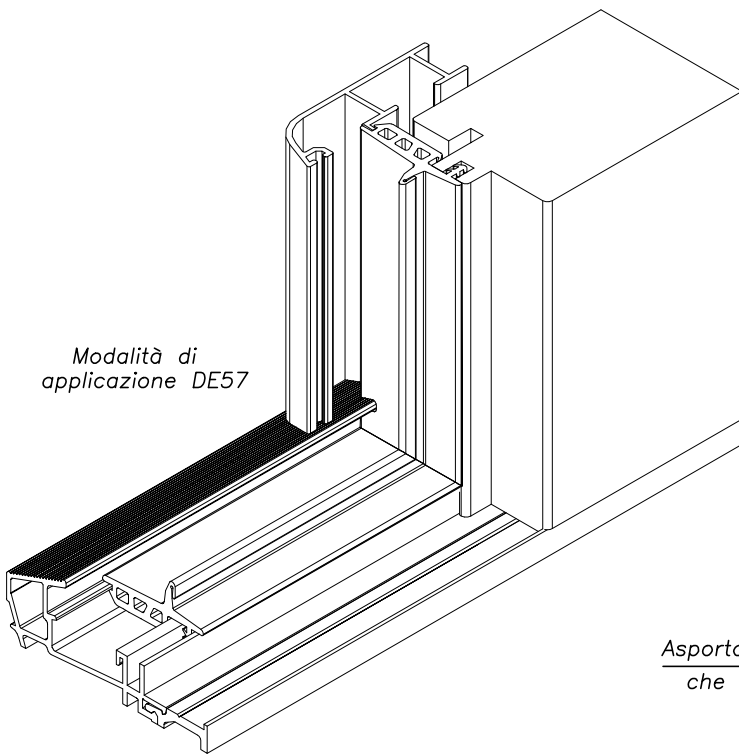

**Vantaggi PA204T**

- Guarnizione DE57 continua
- Taglio termico
- Ferramenta Anti-Effrazione
- Zigrinatura antiscivolo

**Soglia per sistema Soft-Line/45**

Soglia per sistema Soft-Line/45  
 Schwelle für System Soft-Line/45  
 Umbral para sistema Soft-line/45  
 Seuil pour système Soft-Line/45  
 Aluminium sill for system Soft-Line /45



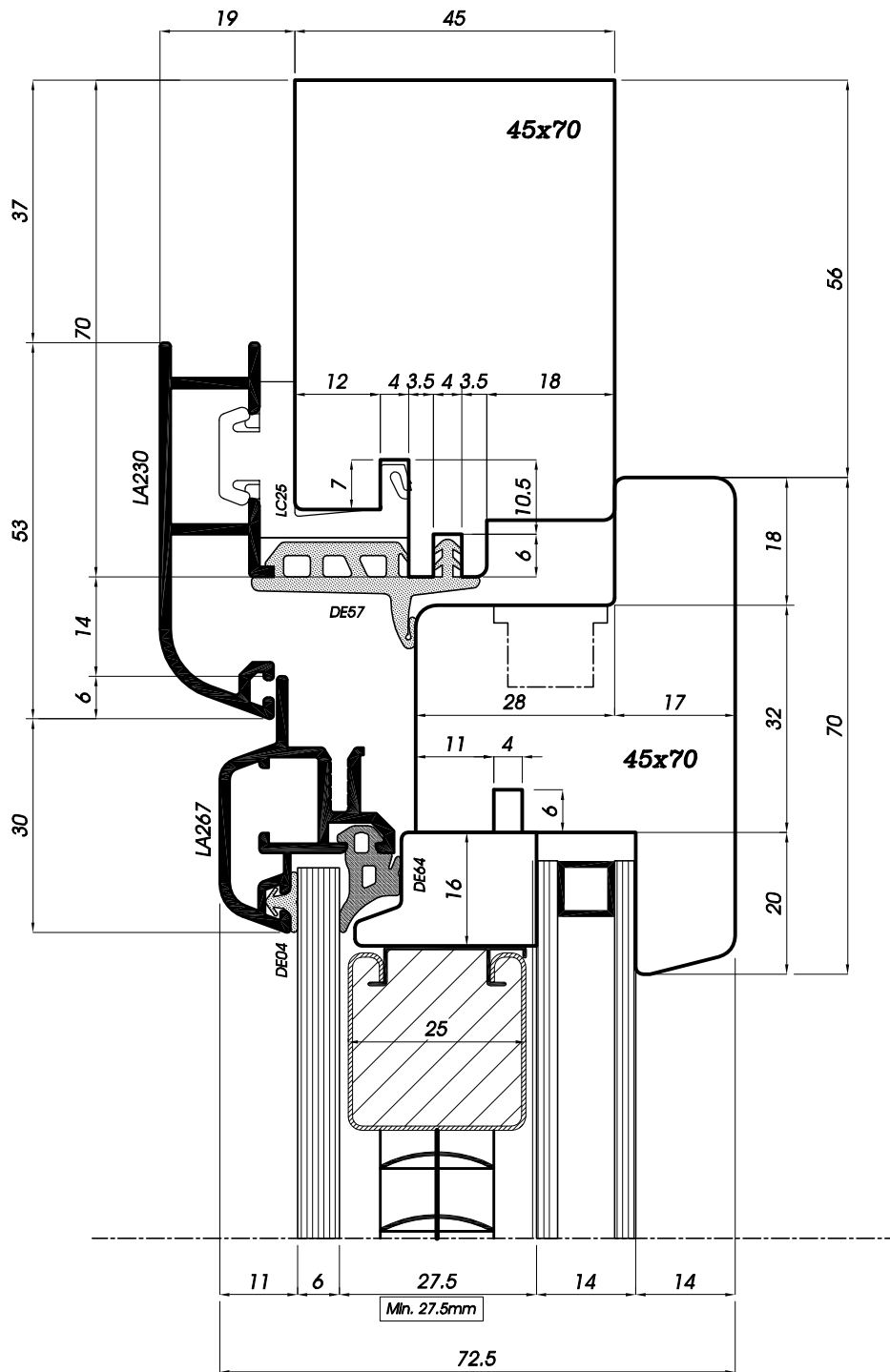
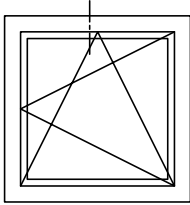

**Sezione verticale traverso superiore finestra**  
**Vertikalschnitt Fenster quer oben**  
**Sección vertical travesaño superior del marco**  
**Coupe verticale traverse supérieure fenêtre**  
**Vertical section of the window's upper ledger**



**GU - TIPP 821**

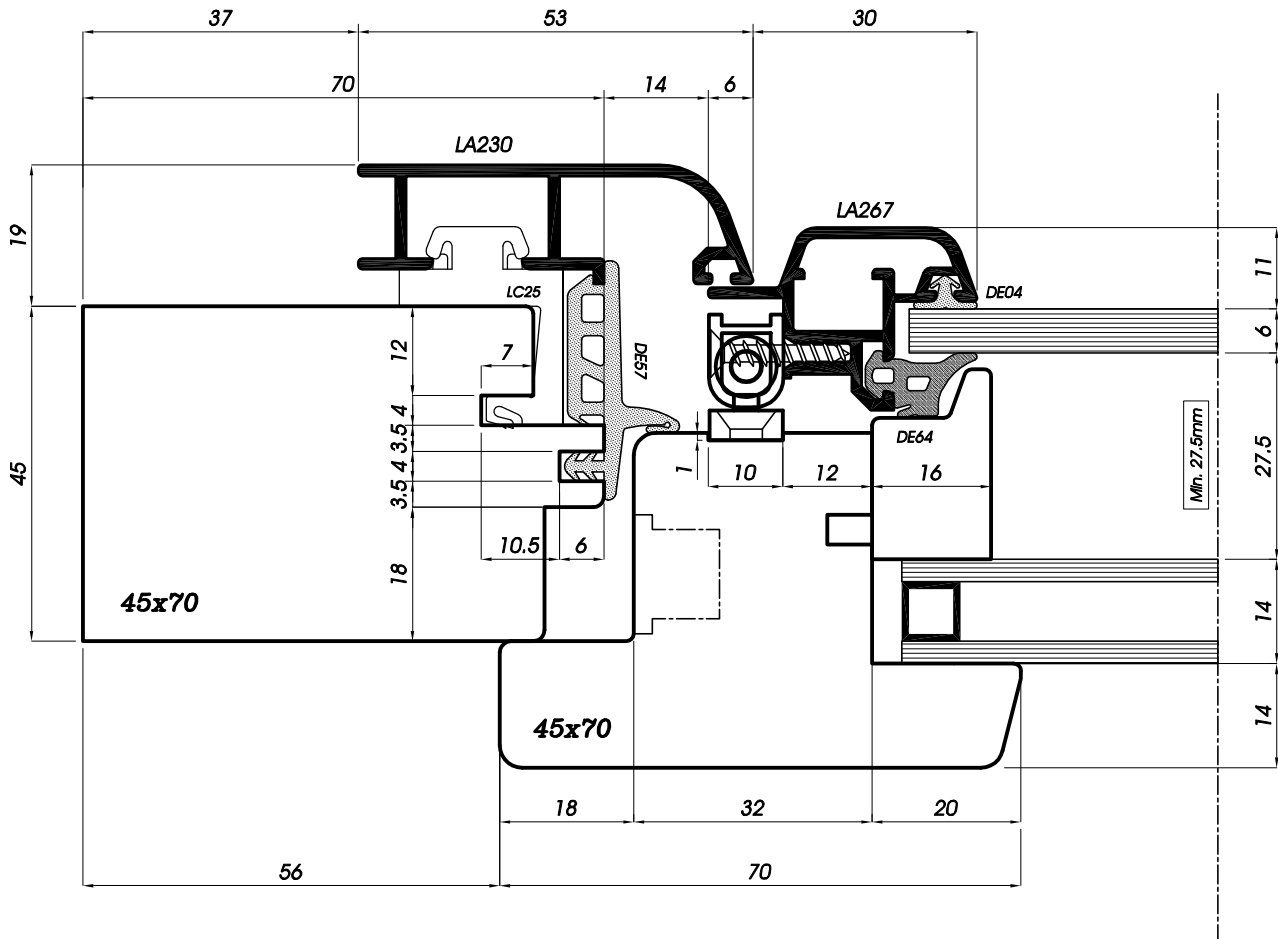
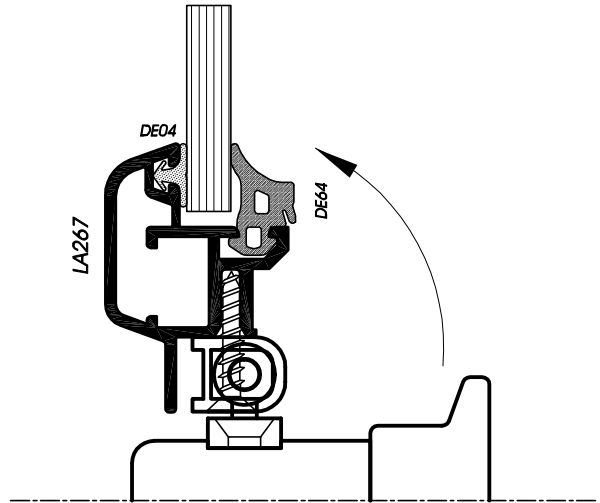
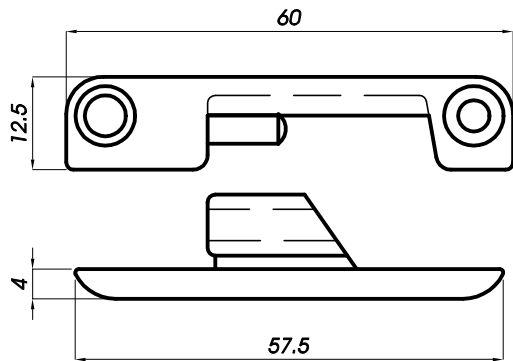

**Sezione orizzontale montante laterale**  
**Horizontalschnitt senkrecht seitlich**  
**Sección horizontal montante lateral**  
**Coupe horizontale du montant latéral**  
**Horizontal section lateral jambs**

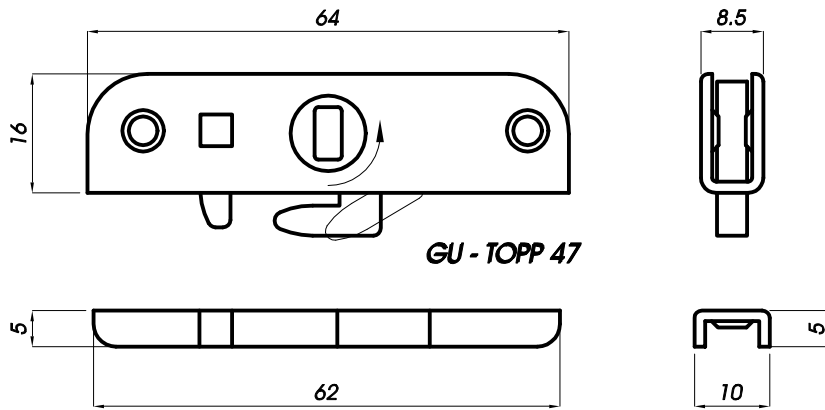

GU - TOPP 47

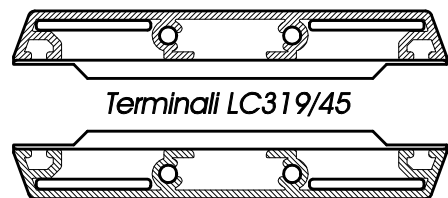
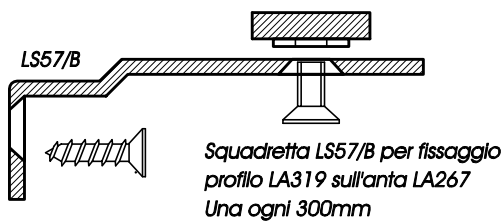
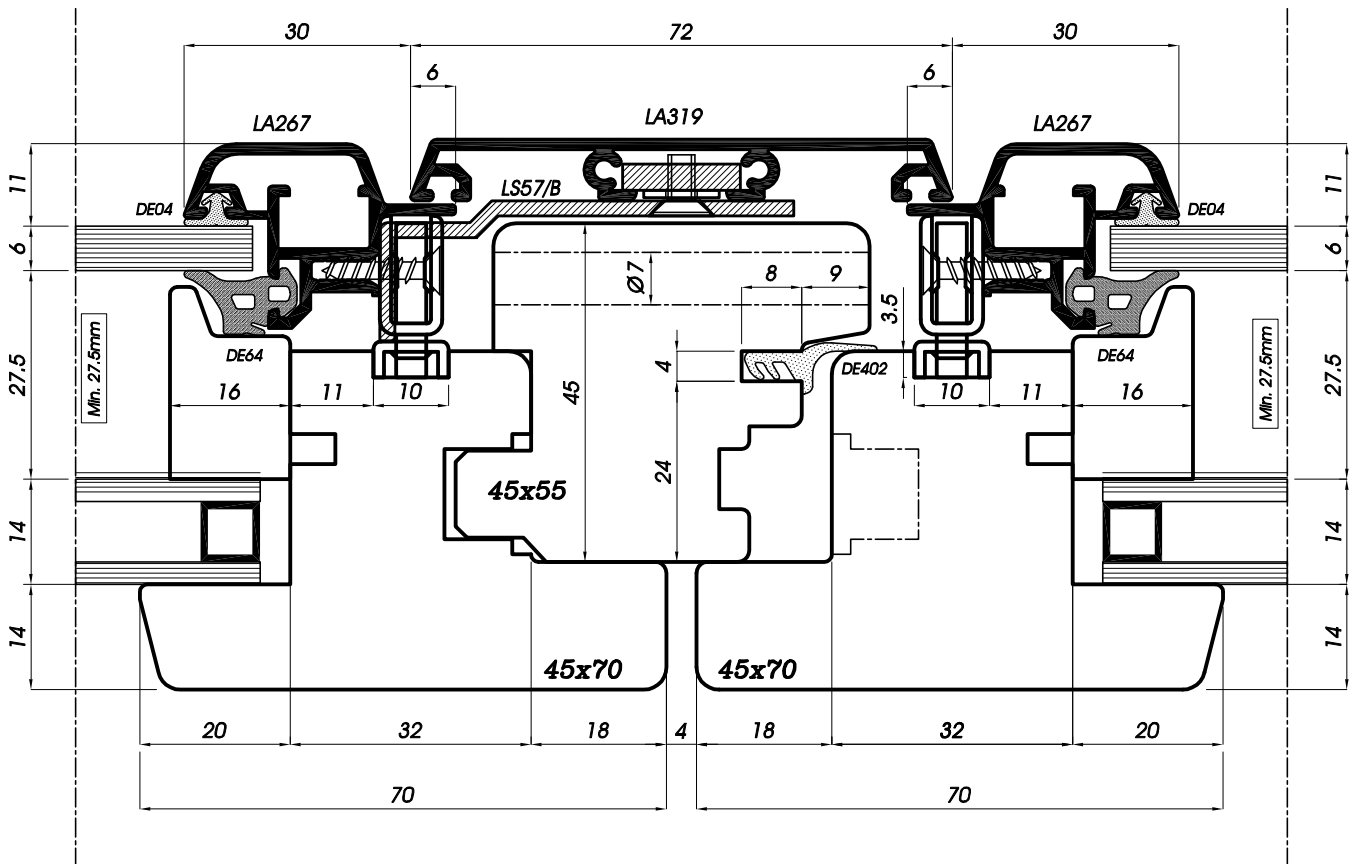

Sezione orizzontale chiusura centrale con profilo LA319  
 Horizontalschnitt Stulpprofil LA319  
 Sección horizontal del cierre central con perfil LA319  
 Coupe horizontale battement central avec profil LA319  
 Horizontal section of the middle clamp with profile LA319

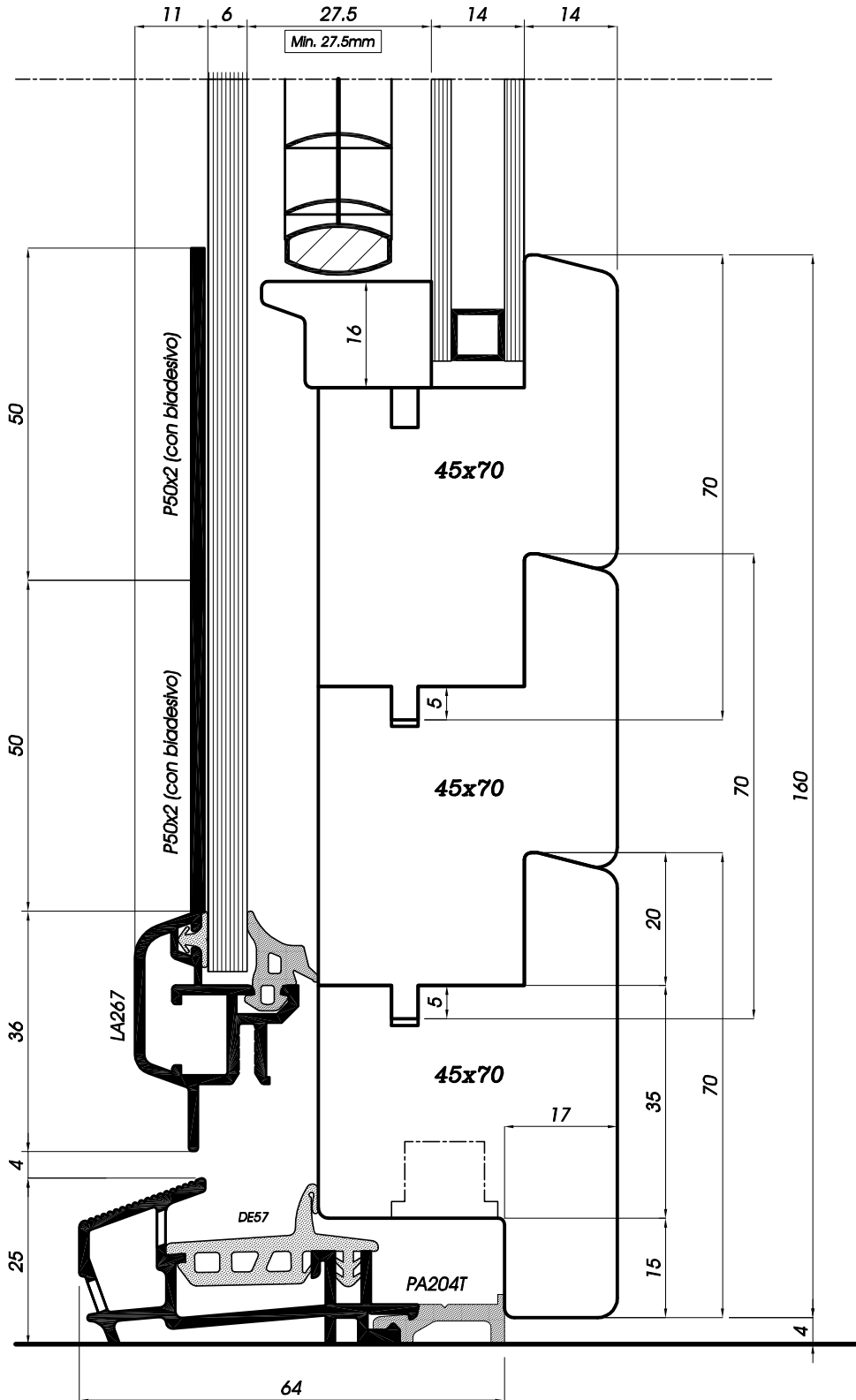

**Sezione verticale traverso inferiore portafinestra con PA204T**  
**Vertikalschnitt Balkontür quer unten mit PA204T**  
**Sección vertical travesaño inferior puertaventana con PA204T**  
**Coupe verticale traverse inférieure porte-fenêtre avec PA204T**  
**Vertical section of the window-door's lower ledger with PA204T**

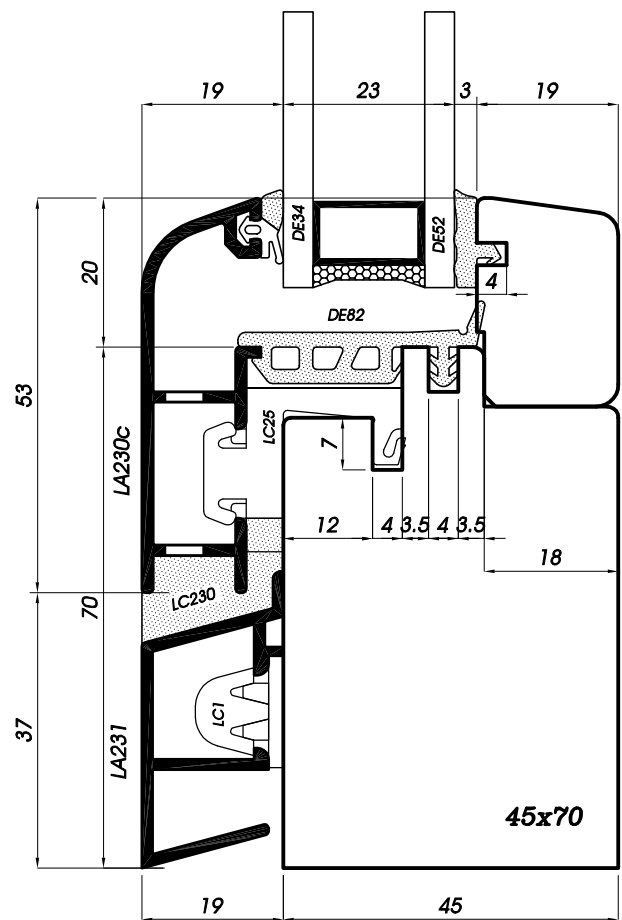
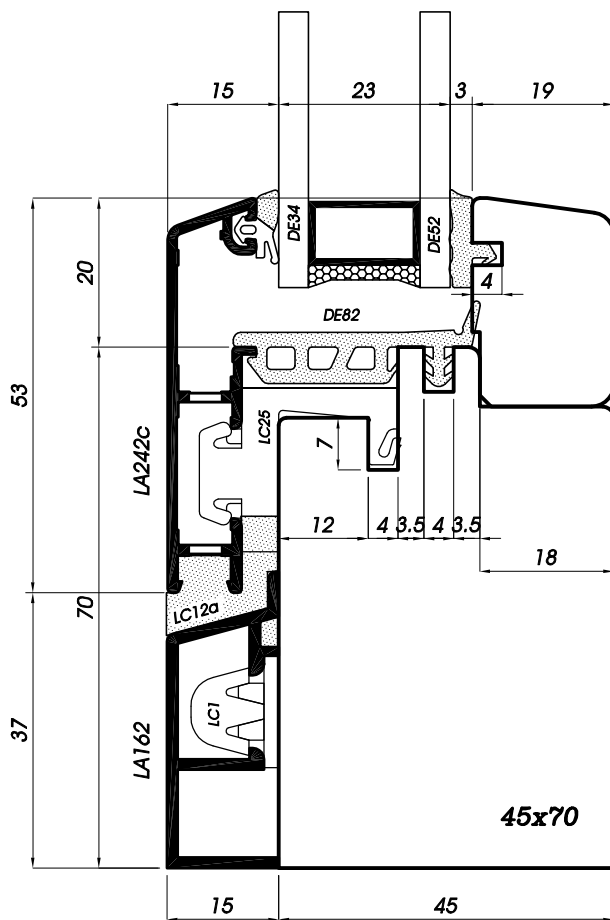
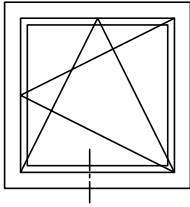

Sezione verticale traverso inferiore vetro fisso  
 Vertikalschnitt Fenster quer unten Fixverglasung  
 Sección vertical travesaño inferior con cristal fijo  
 Coupe verticale traverse inférieure fenêtre avec vitre fixe  
 Vertical section of the window's lower ledger for fixed glass

# Sistema LIGHT/45

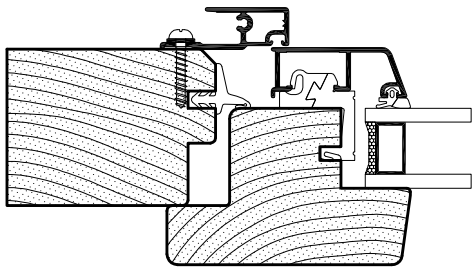

*LIGHT/45 senza guida*

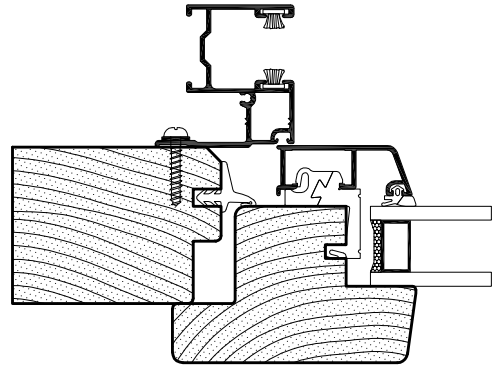

*LIGHT/45 con guida*

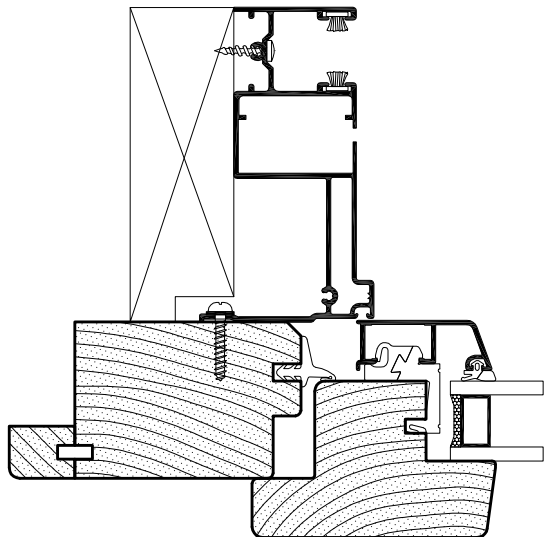

*LIGHT/45 Monoblocco  
zanzariera + guida*

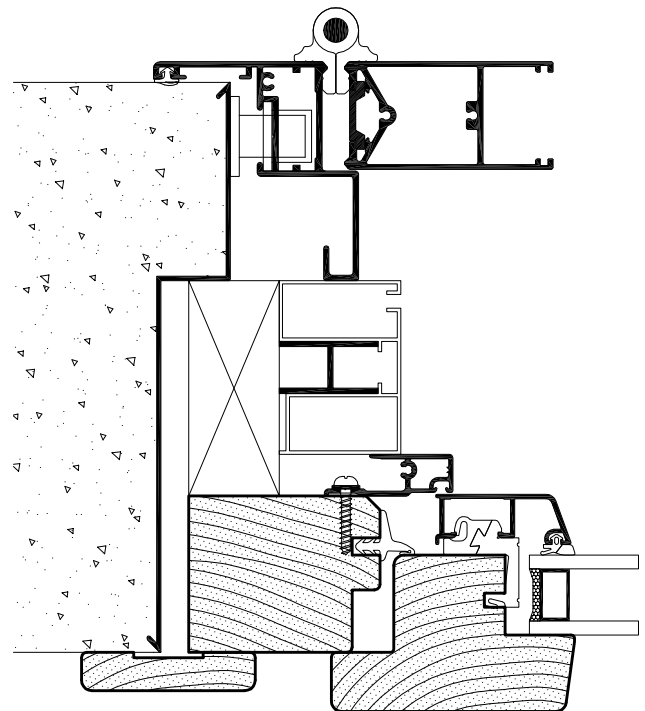

*LIGHT/45 Monoblocco  
zanzariera + scuretto 30mm*

Variante con  
guarnizione DE52

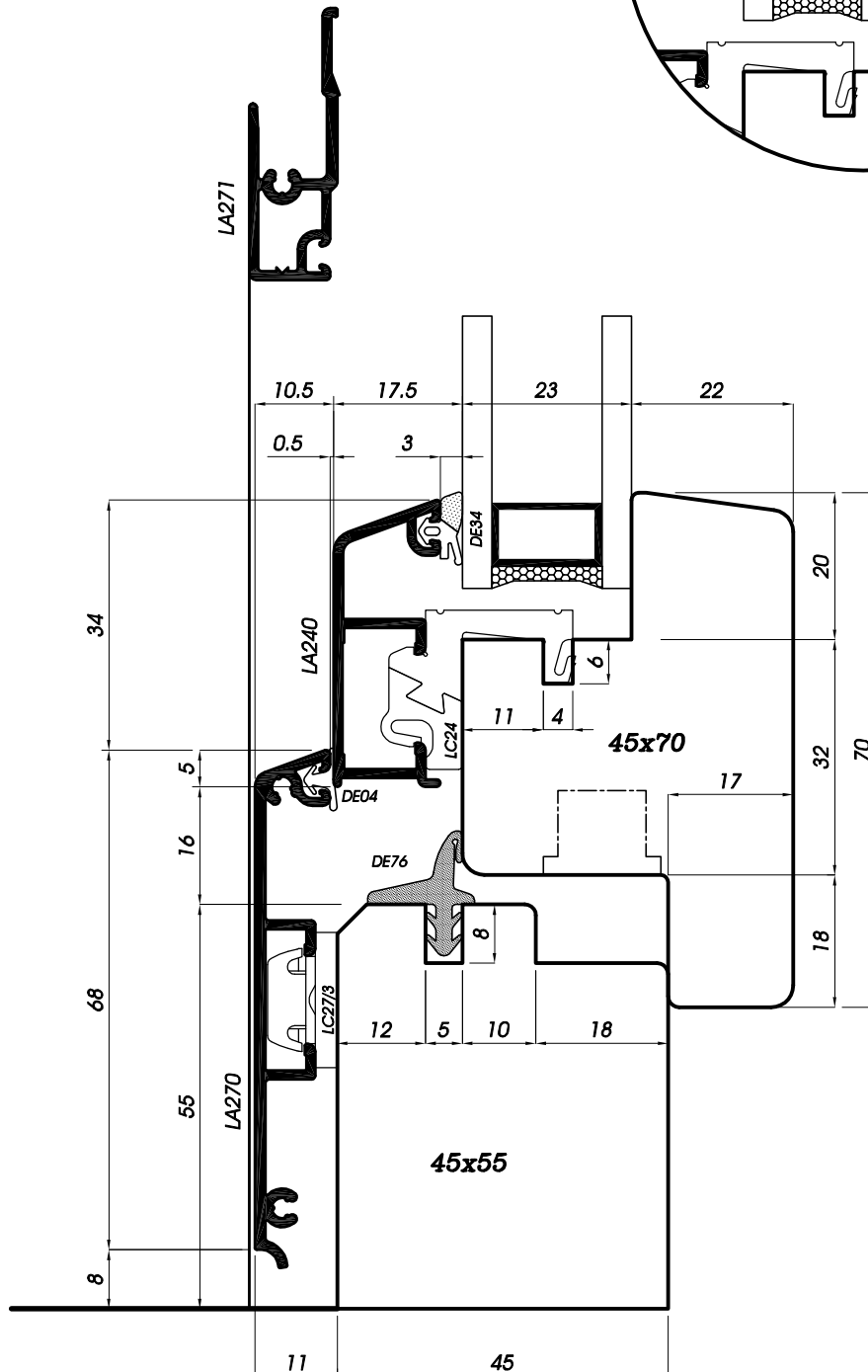
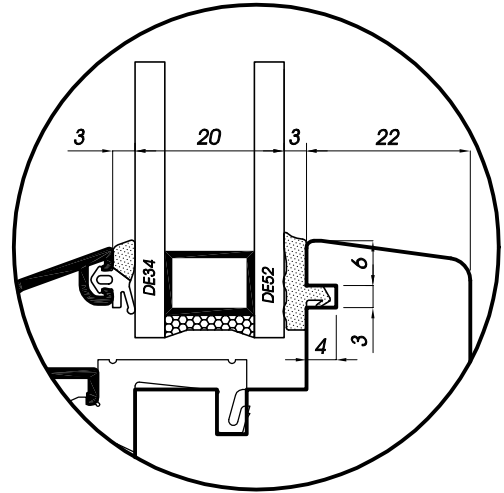
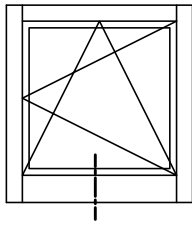

Sezione verticale traverso inferiore finestra  
 Vertikalschnitt Fenster quer unten  
 Sección vertical travesaño inferior de la ventana  
 Coupe verticale traverse inférieure fenêtre  
 Vertical section of the window's lower ledger

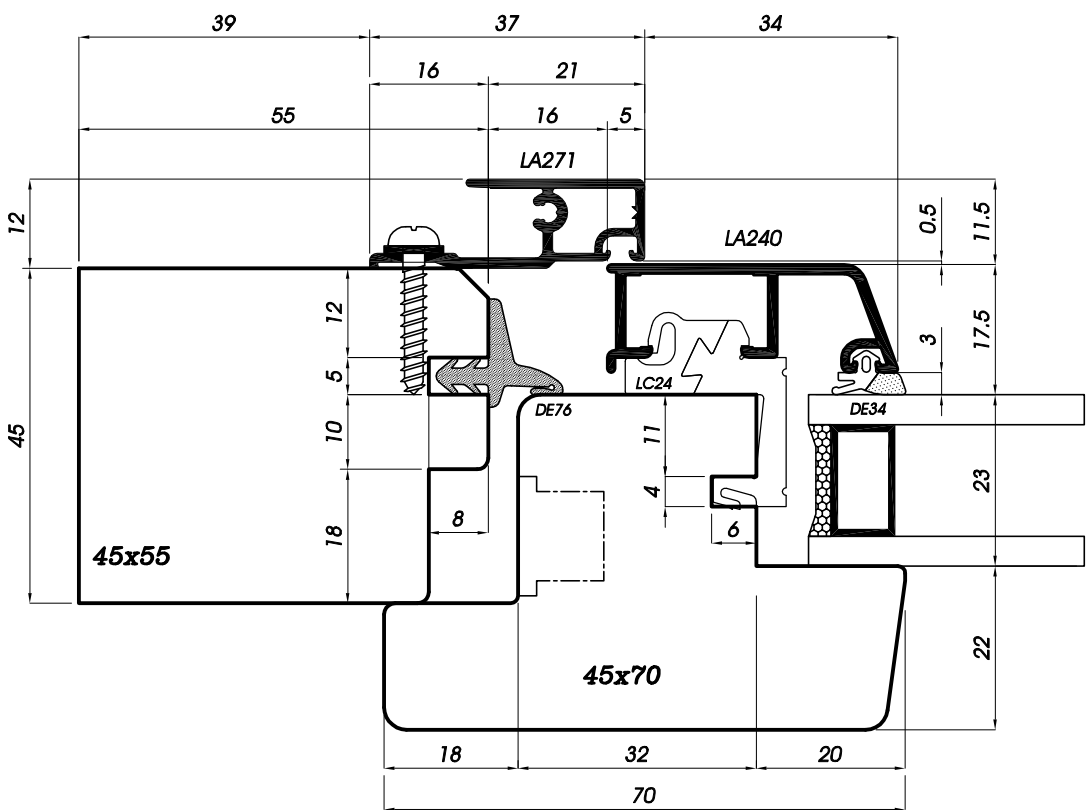
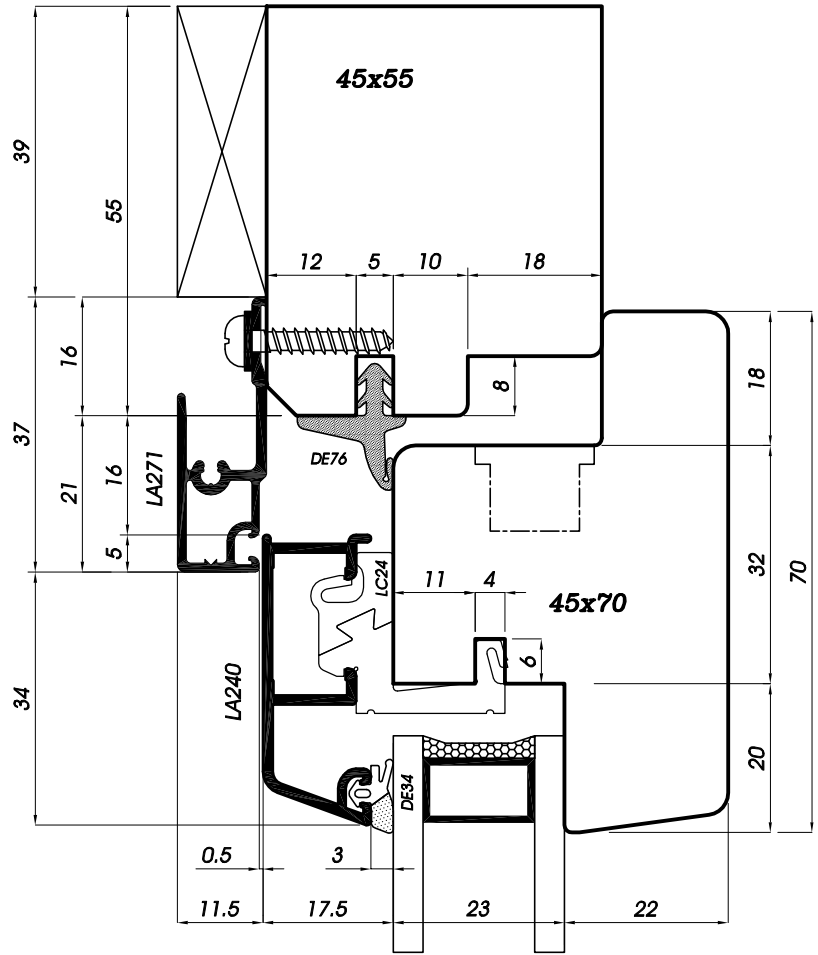
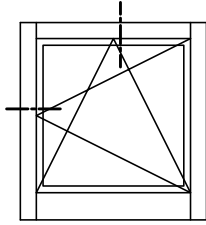

Sezione orizzontale montante laterale e sezione verticale traverso superiore  
 Horizontalschnitt senkrecht seitlich und Vertikalschnitt quer oben  
 Sección horizontal montante lateral y sección vertical travesañ superior de la ventana  
 Coupe horizontale montants latéraux et coupe verticale traverse supérieure fenêtre  
 Horizontal section of the lateral jamb and vertical section of the upper ledger

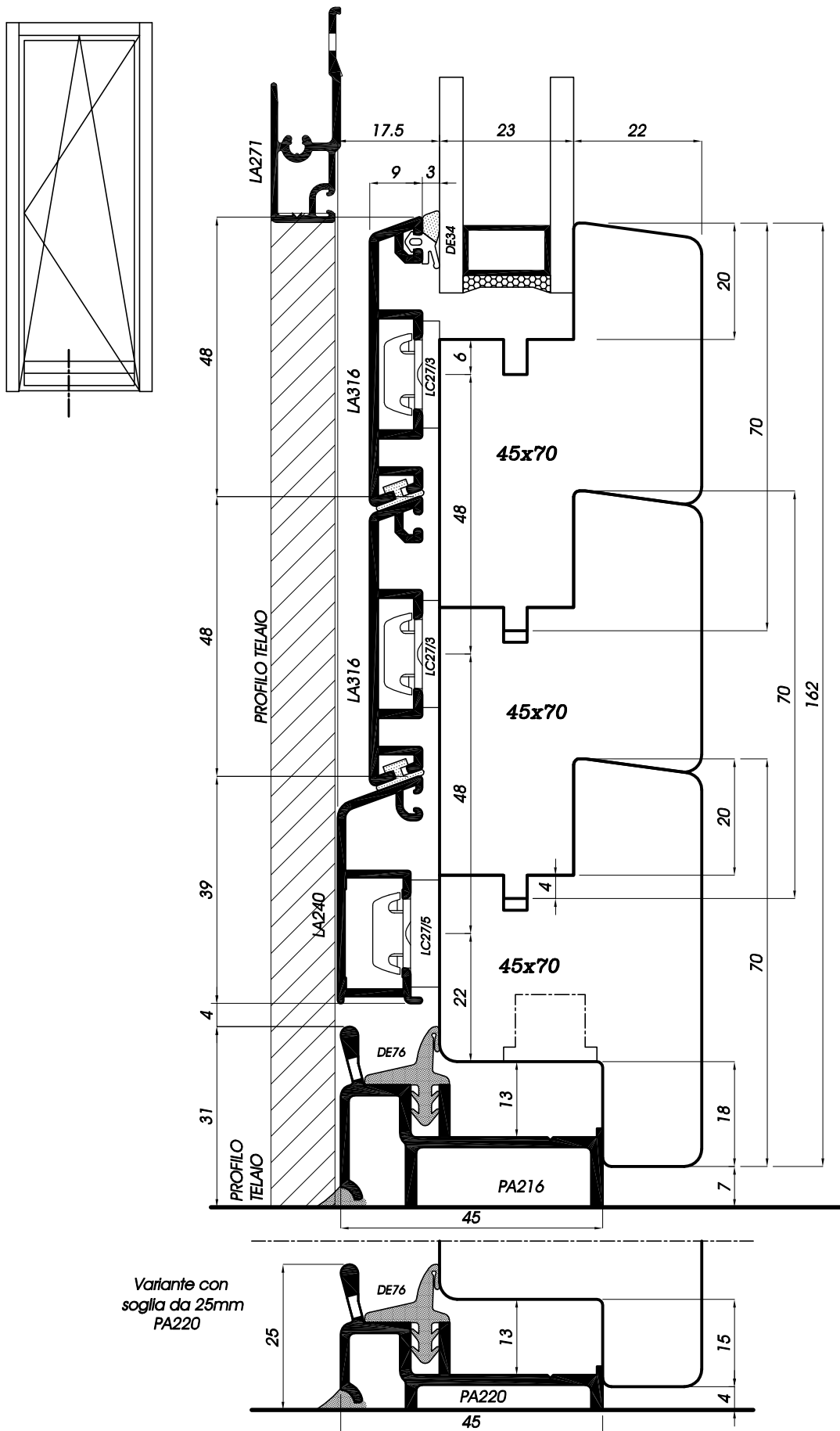

**Sezione verticale traverso inferiore portafinestra con PA216-PA220**  
**Vertikalschnitt Balkontür quer unten mit PA216-PA220**  
**Sección vertical travesaño inferior puertaventana con PA216-PA220**  
**Coupe verticale traverse inférieure porte-fenêtre avec PA216-PA220**  
**Vertical section of the window-door's lower ledger with PA216-PA220**



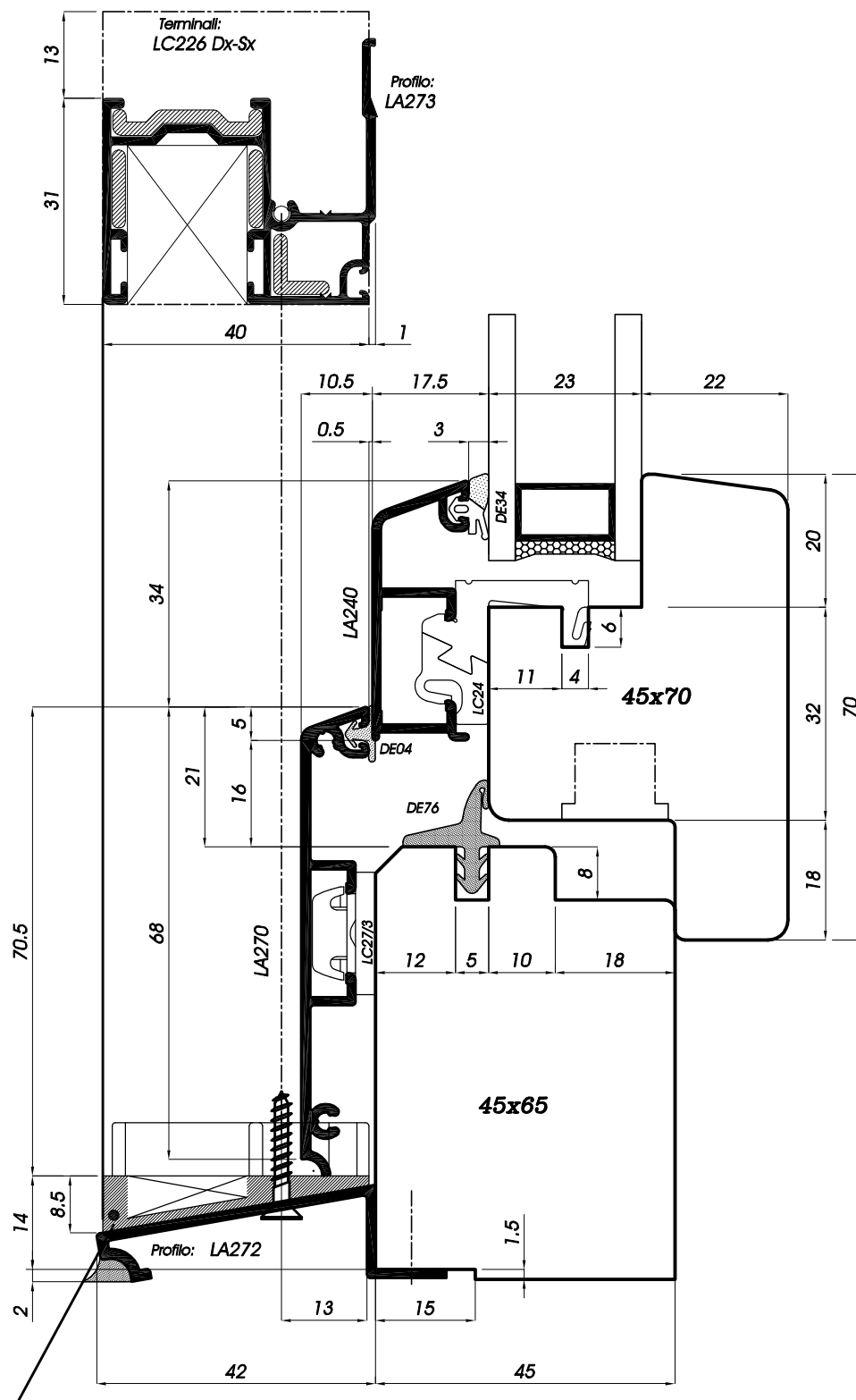
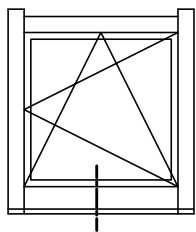

Terminali LC226 Dx-Sx

Sezione verticale traverso inferiore finestra  
 Vertikalschnitt Fenster quer unten  
 Sección vertical travesaño inferior de la ventana  
 Coupe verticale traverse inférieure fenêtré  
 Vertical section of the window's lower ledger

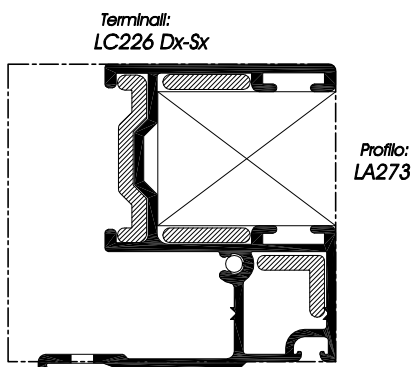
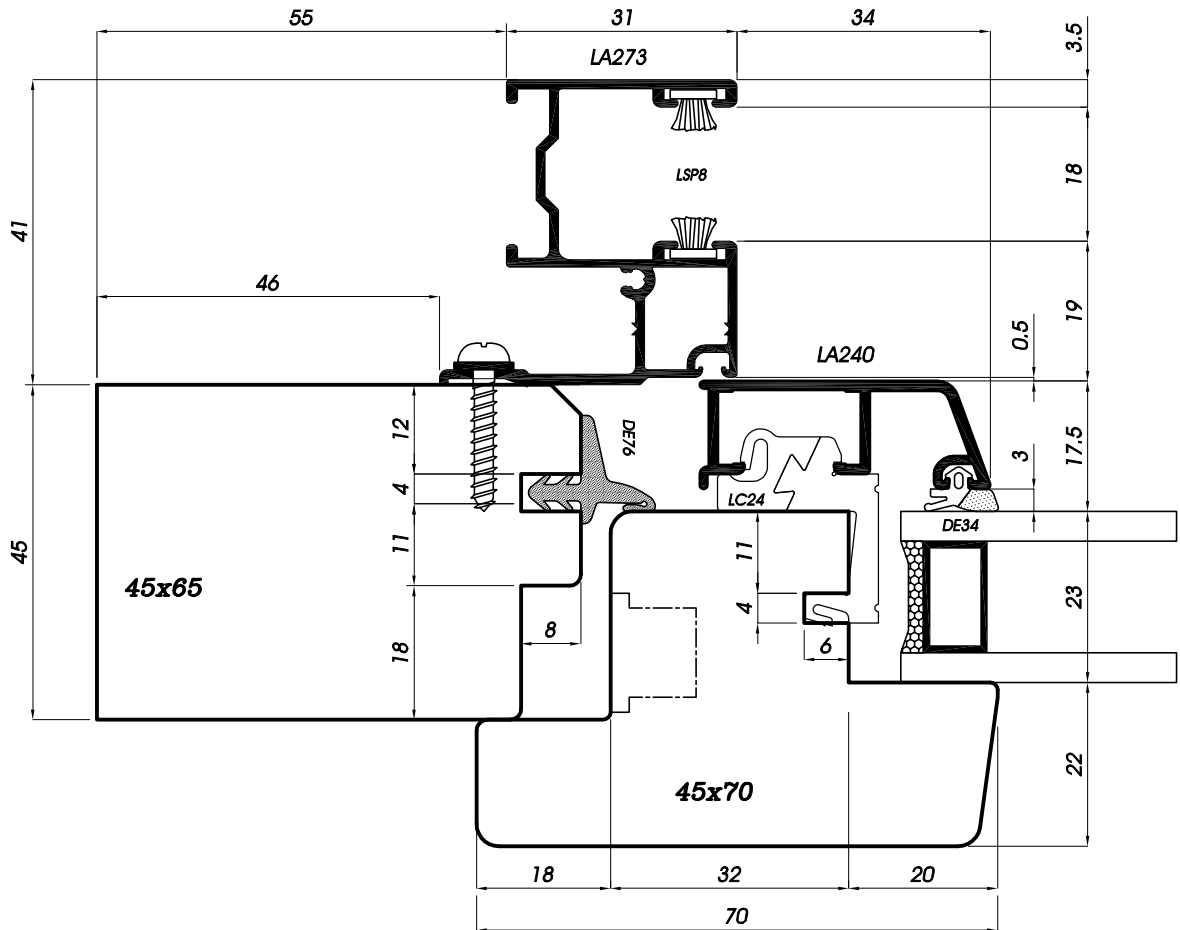
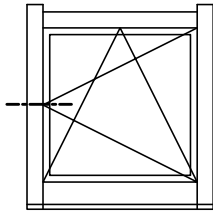

Sezione orizzontale montante laterale  
 Horizontalschnitt senkrecht seitlich  
 Sección horizontal del montante lateral  
 Coupe horizontale du montant latéral  
 Horizontal section of the lateral jamb

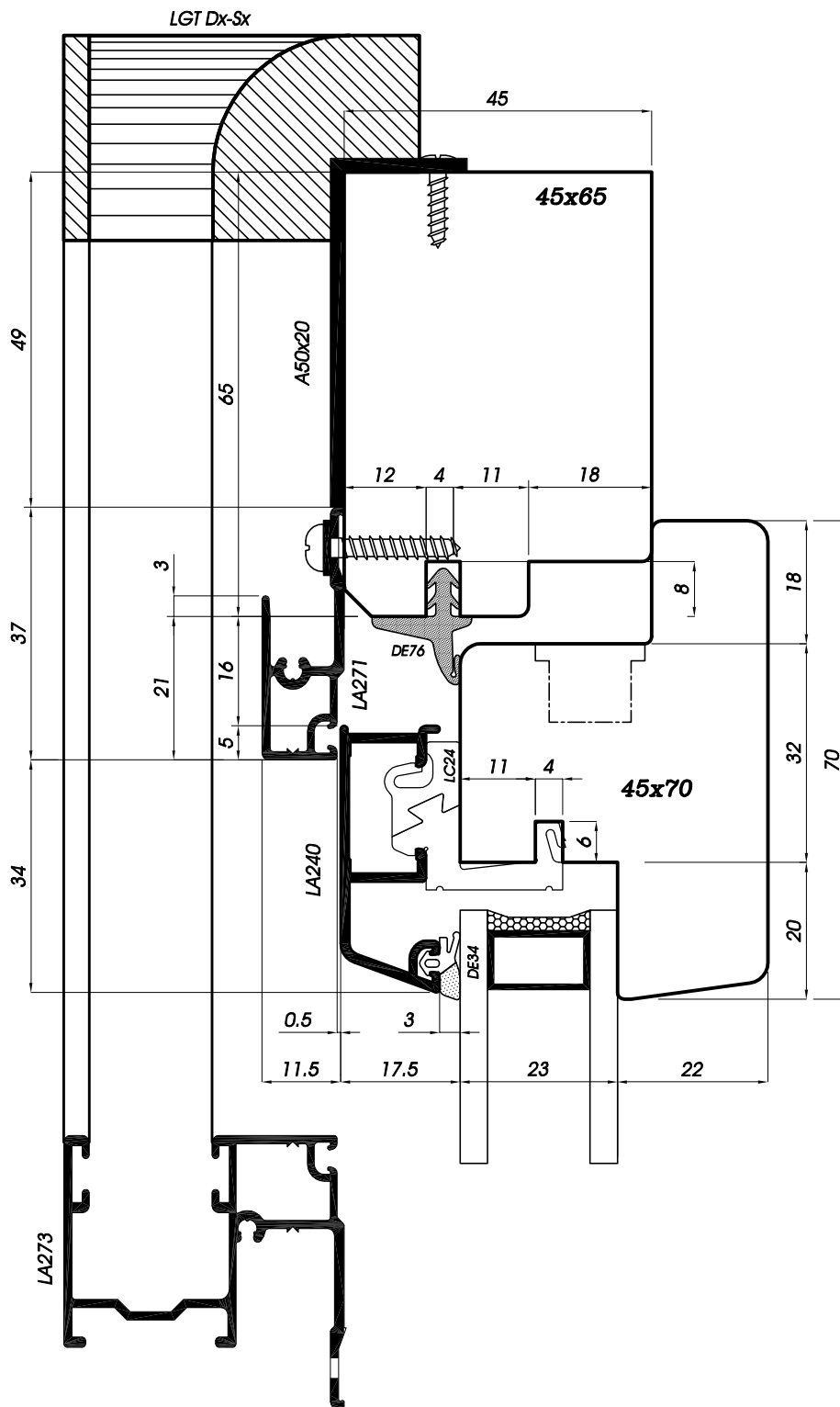
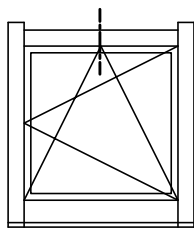

Sezione verticale traverso superiore finestra  
 Vertikalschnitt Fenster quer oben  
 Sección vertical travesaño superior de la ventana  
 Coupe verticale traverse supérieure fenêtr  
 Vertical section of the window's upper ledger

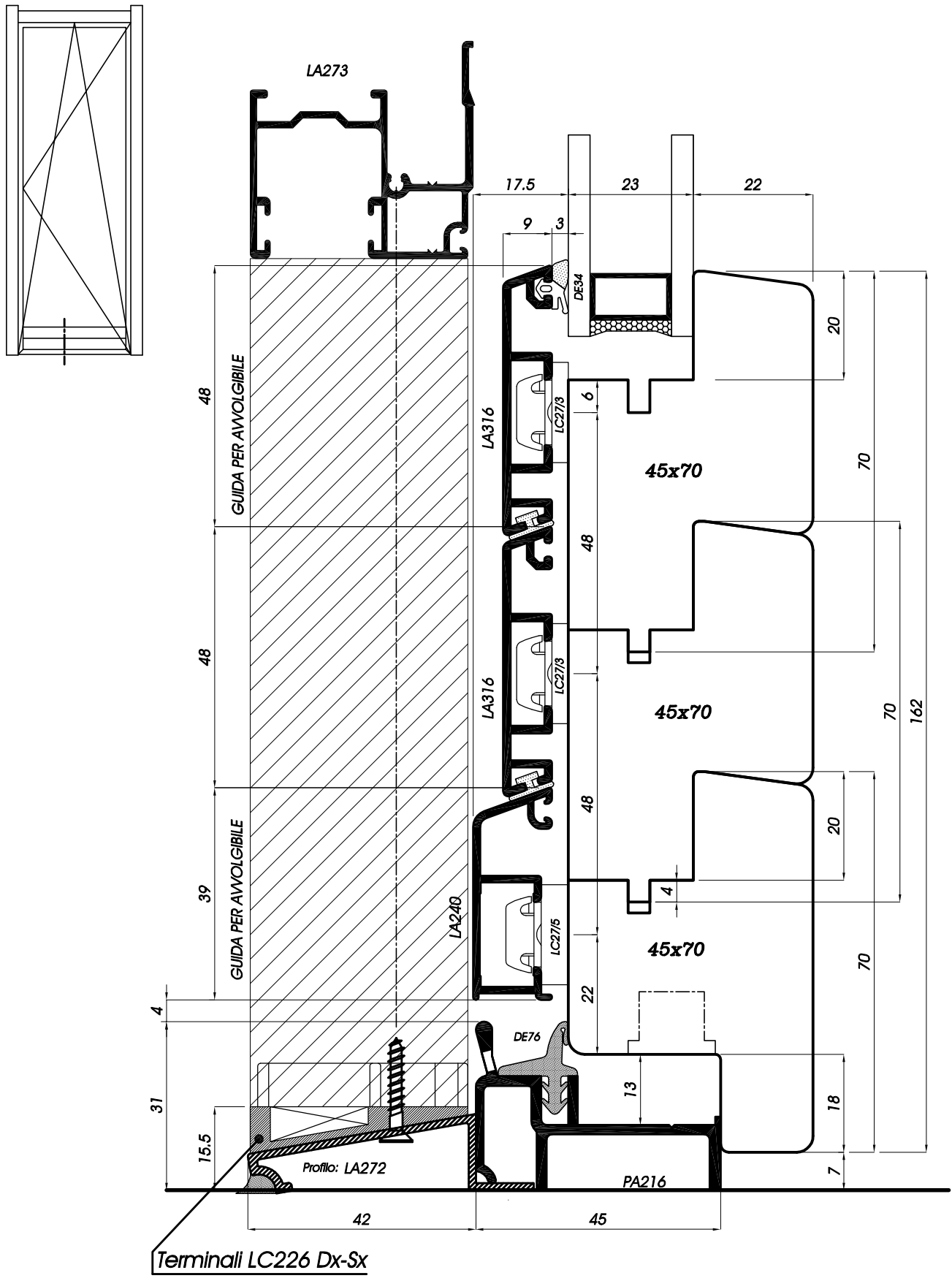

Terminali LC226 Dx-Sx

Sezione verticale traverso inferiore portafinestra con PA216+LA272  
 Vertikalschnitt Balkontür quer unten mit PA216+LA272  
 Sección vertical travesaño inferior puertaventana con PA216+LA272  
 Coupe verticale traverse inférieure porte-fenêtre avec PA216+LA272  
 Vertical section of the window-door's lower ledger with PA216+LA272

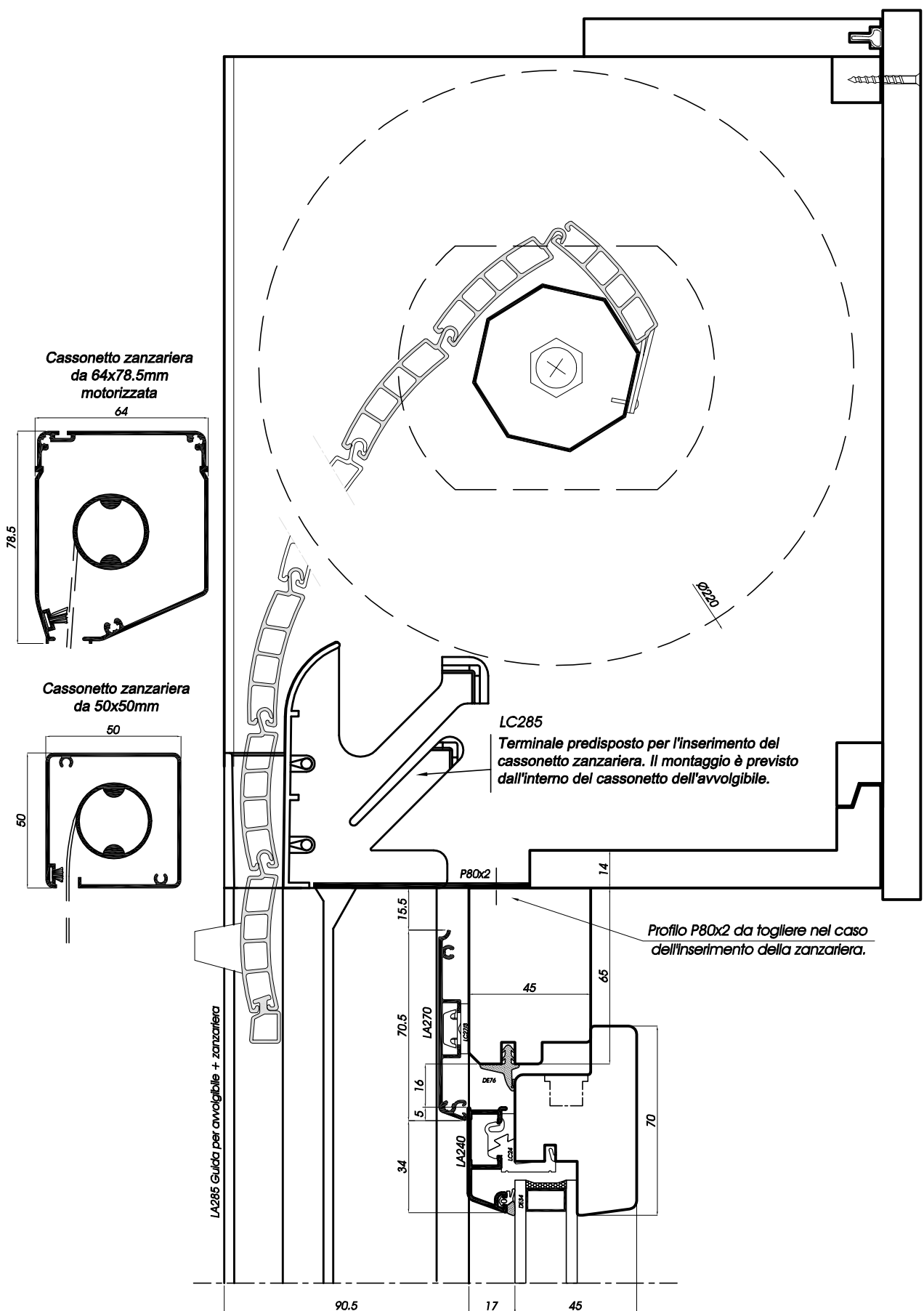

**Sezione verticale traverso superiore finestra con monoblocco**  
**Vertikalschnitt quer oben Fenster mit Rolladenkasten**  
**Sección vertical travesaño superior de ventana con monoblock**  
**Coupe verticale traverse supérieure fenêtré monobloc**  
**Vertical section of the window's upper ledger with enbloc**

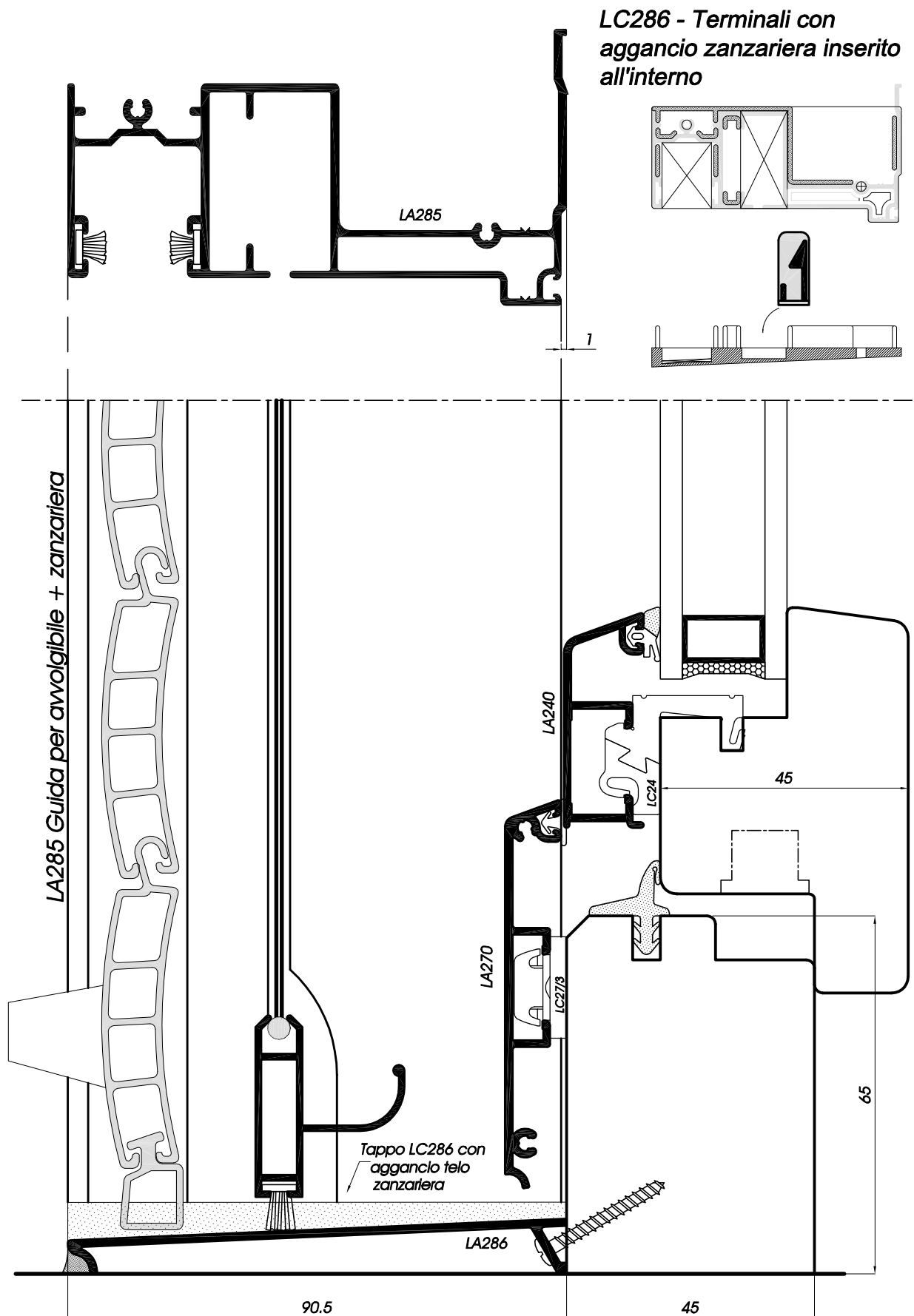

Sezione verticale traverso inferiore finestra con monoblocco  
 Vertikalschnitt quer unten Fenster mit Rolladenkasten  
 Sección vertical travesaño inferior de ventana con monoblock  
 Coupe verticale traverse inférieure fenêtre monobloc  
 Vertical section of the window's lower ledger with enbloc

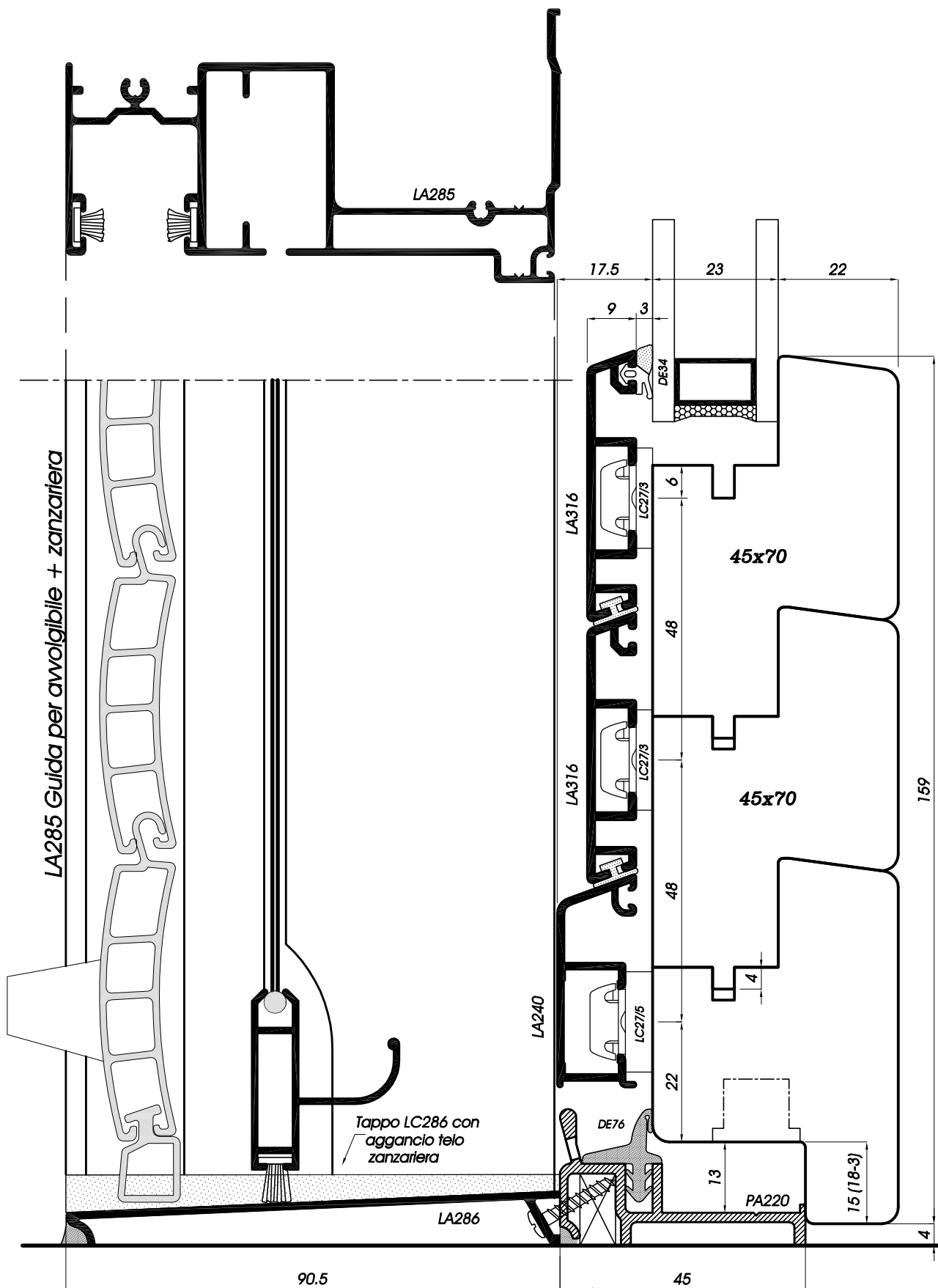

Sezione verticale traverso inferiore portafinestra con monoblocco  
 Vertikalschnitt quer unten Balkontür mit Rolladenkasten  
 Sección vertical travesaño inferior de puertaventana con monoblock  
 Coupe verticale traverse inférieure porte-fenêtre monobloc  
 Vertical section of the window-door's lower ledger with enbloc

Terminali LC319/45

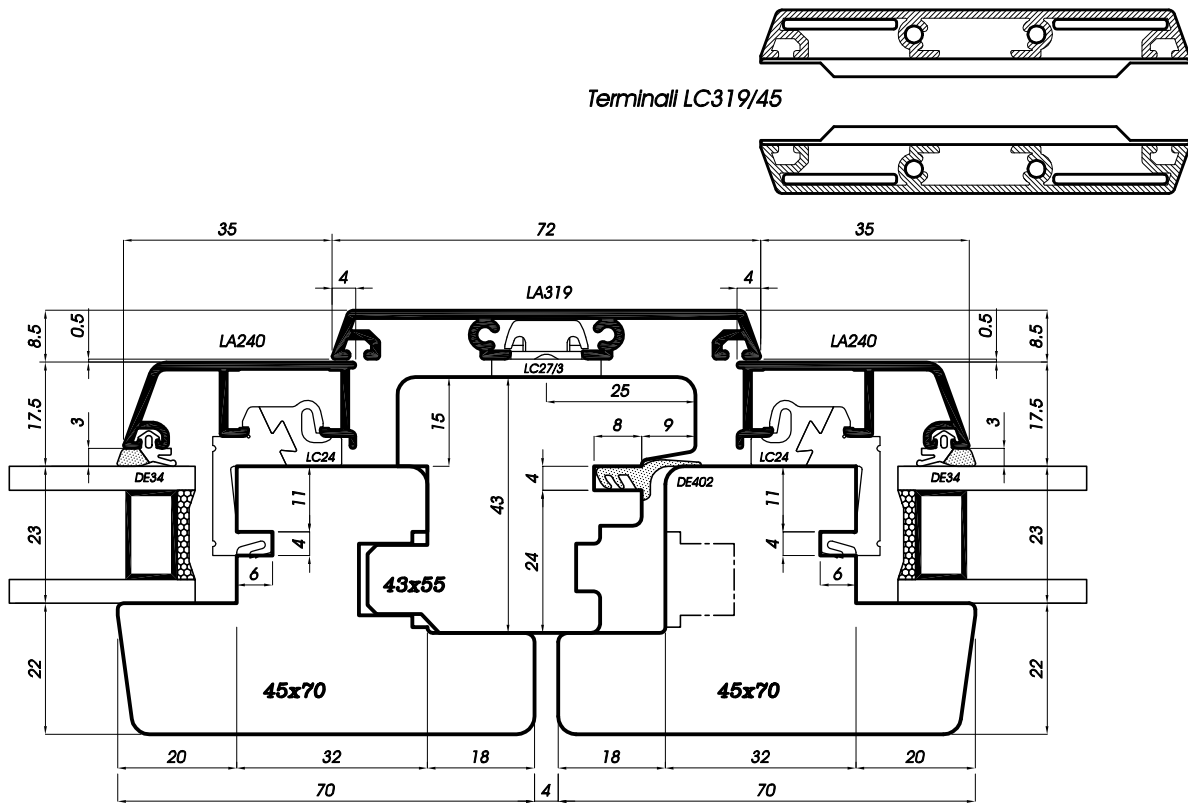

Terminali LC180

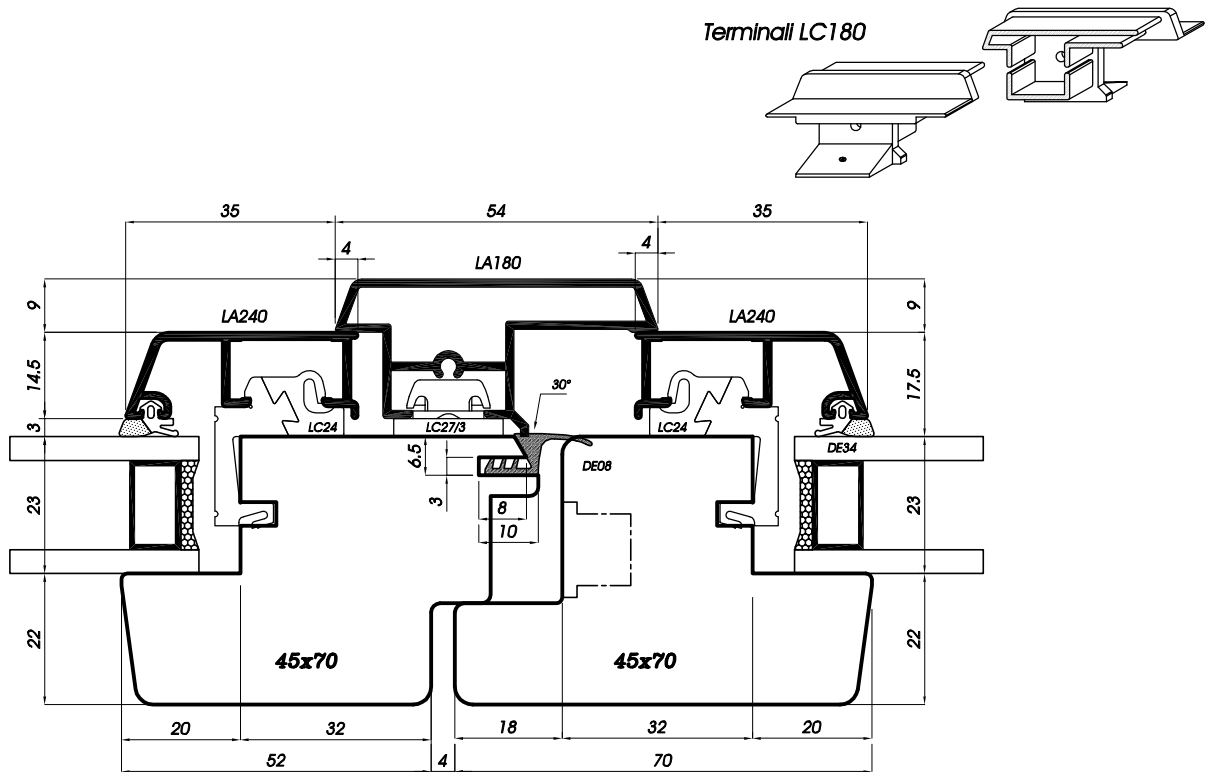

Sezione orizzontale chiusura centrale con profili LA319-LA180  
 Horizontalschnitt Stulprofil LA319-LA180  
 Sección horizontal del cierre central con perfiles LA319-LA180  
 Coupe horizontale battement central avec profil LA319 - LA180  
 Horizontal section of the middle clamp with profiles LA319-LA180



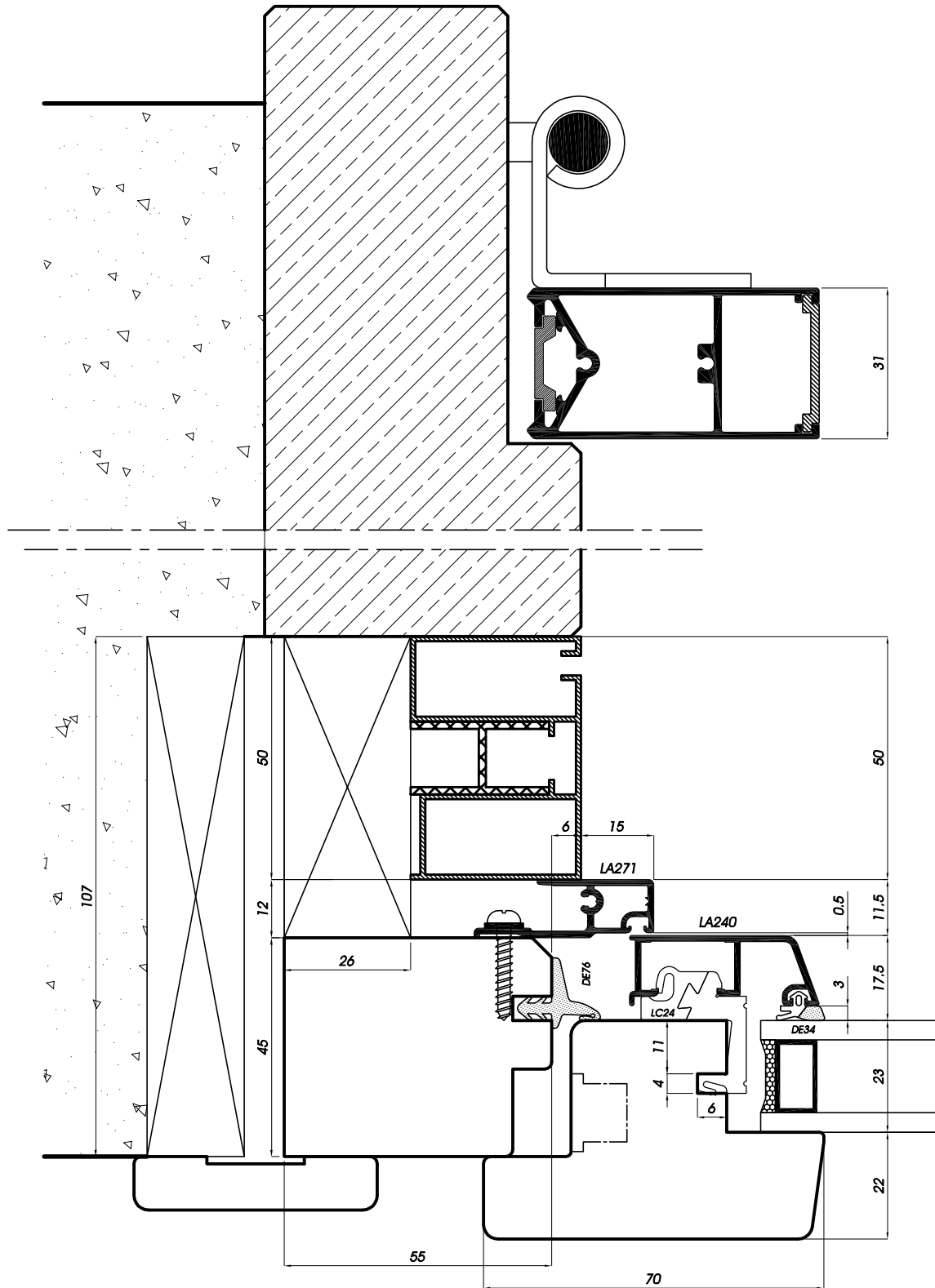

**Sezione orizzontale montante laterale con scuretto 30mm in battuta su marmo**  
**Horizontalschnitt seitlich mit Fensterladen 30mm mit Anschlag auf Marmor**  
**Sección horizontal del montante lateral con contraventana de 30 mms en glace sobre el mármol**  
**Coupe horizontale du montant laréral de la fenêtre avec volet ep.30 mm, pose en tableau**  
**Horizontal section of a vertical window jamb with jalouise 30mm thick fixed on the marble**

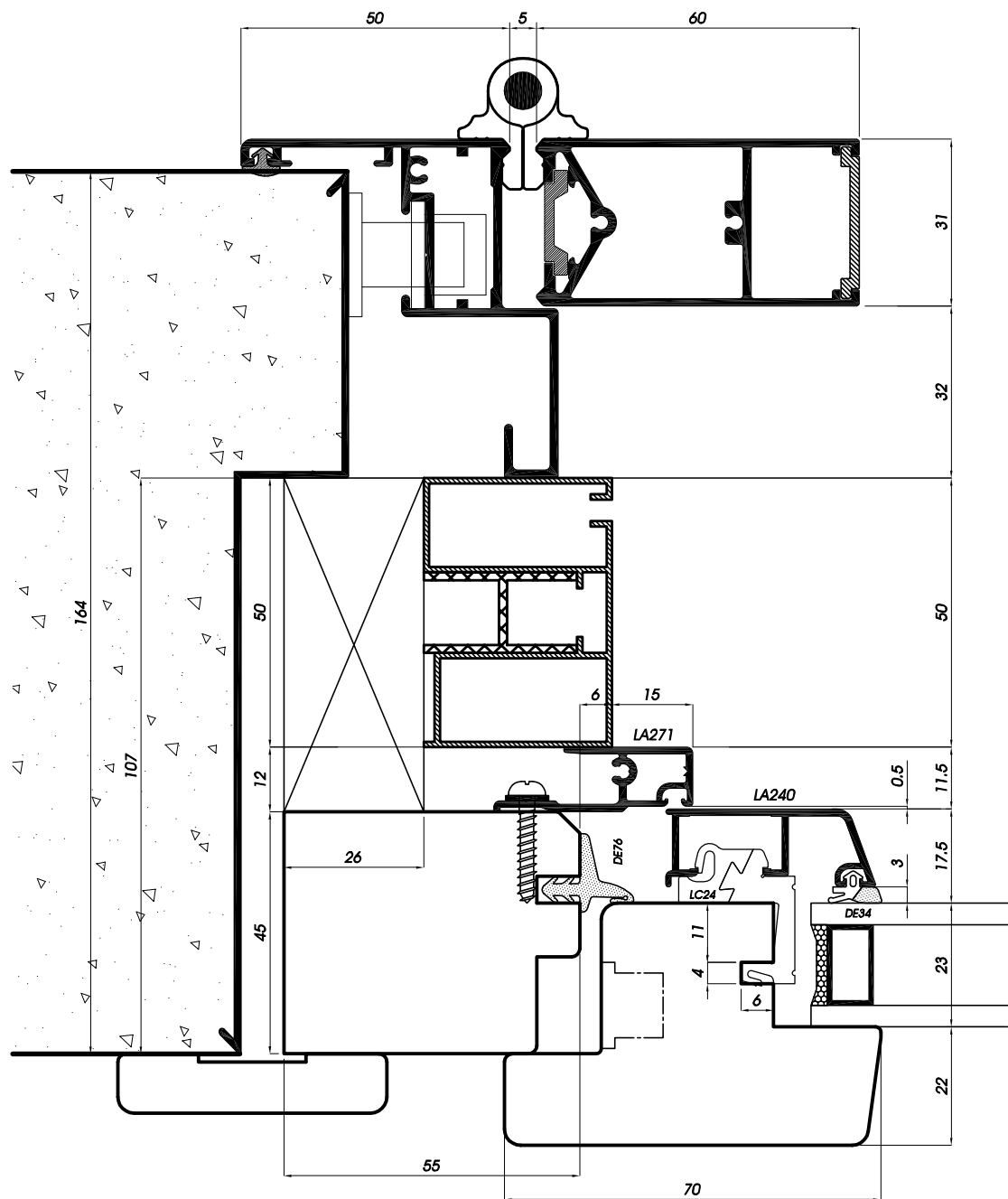

**Sezione orizzontale montante laterale con scuretto 30mm con telaio**  
**Horizontalschnitt seitlich mit Fensterladen 30mm mit Rahmen**  
**Sección horizontal del montante lateral con contraventana de 30 mms con el marco**  
**Coupe horizontale du montant latéral de la fenêtre avec volet ep. 30mm et son cadre dormant**  
**Horizontal section of a vertical window jamb with jalouise 30mm thick fixed on the frame**

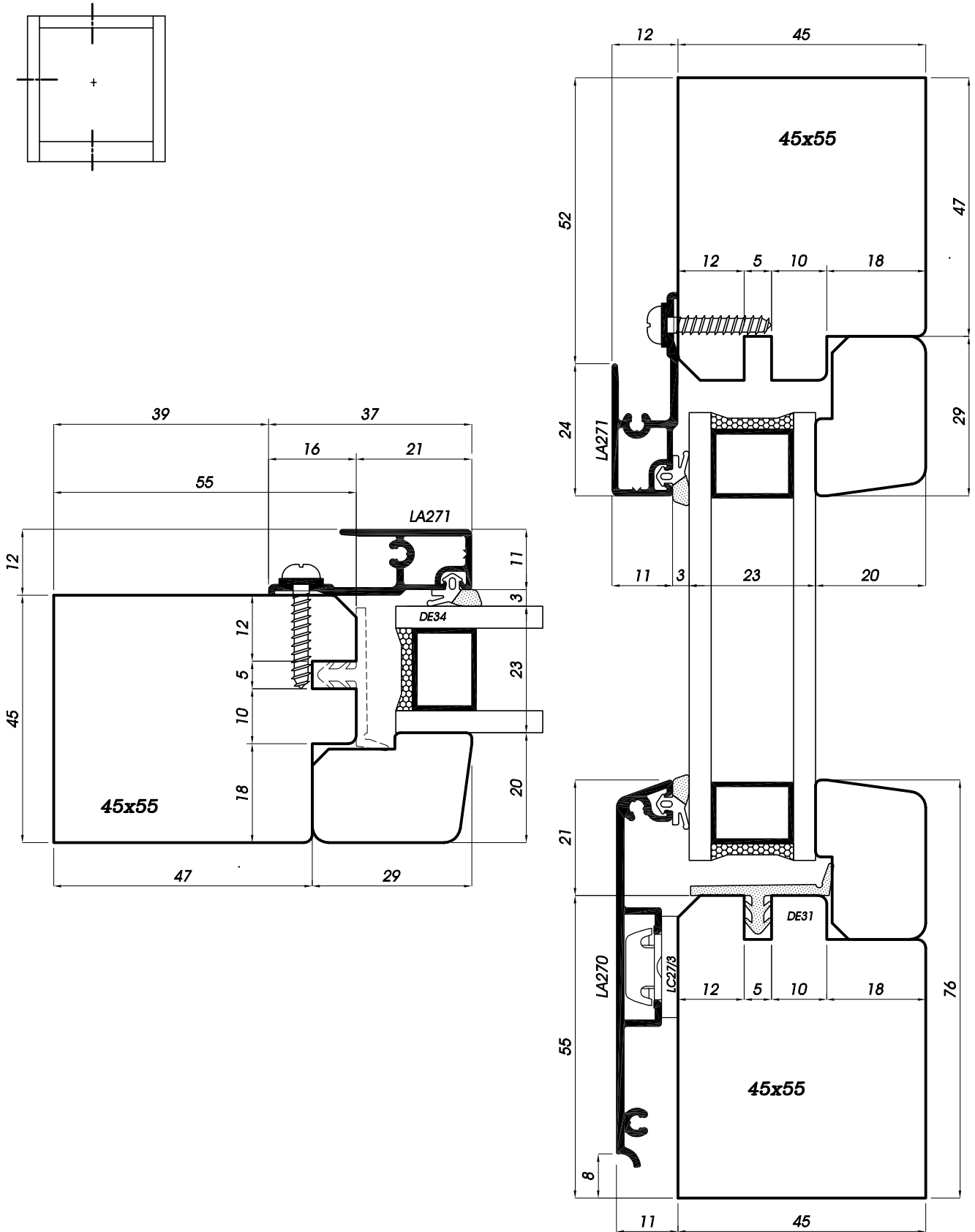

Sezione orizzontale e verticale finestra con vetro fisso  
 Horizontal- und Vertikalschnitt Fenster Fixverglasung  
 Sección horizontal y vertical ventana con cristal fijo  
 Coupe horizontale et verticale fenêtre avec vitre fixe  
 Horizontal and vertical section of the window with fixed glass

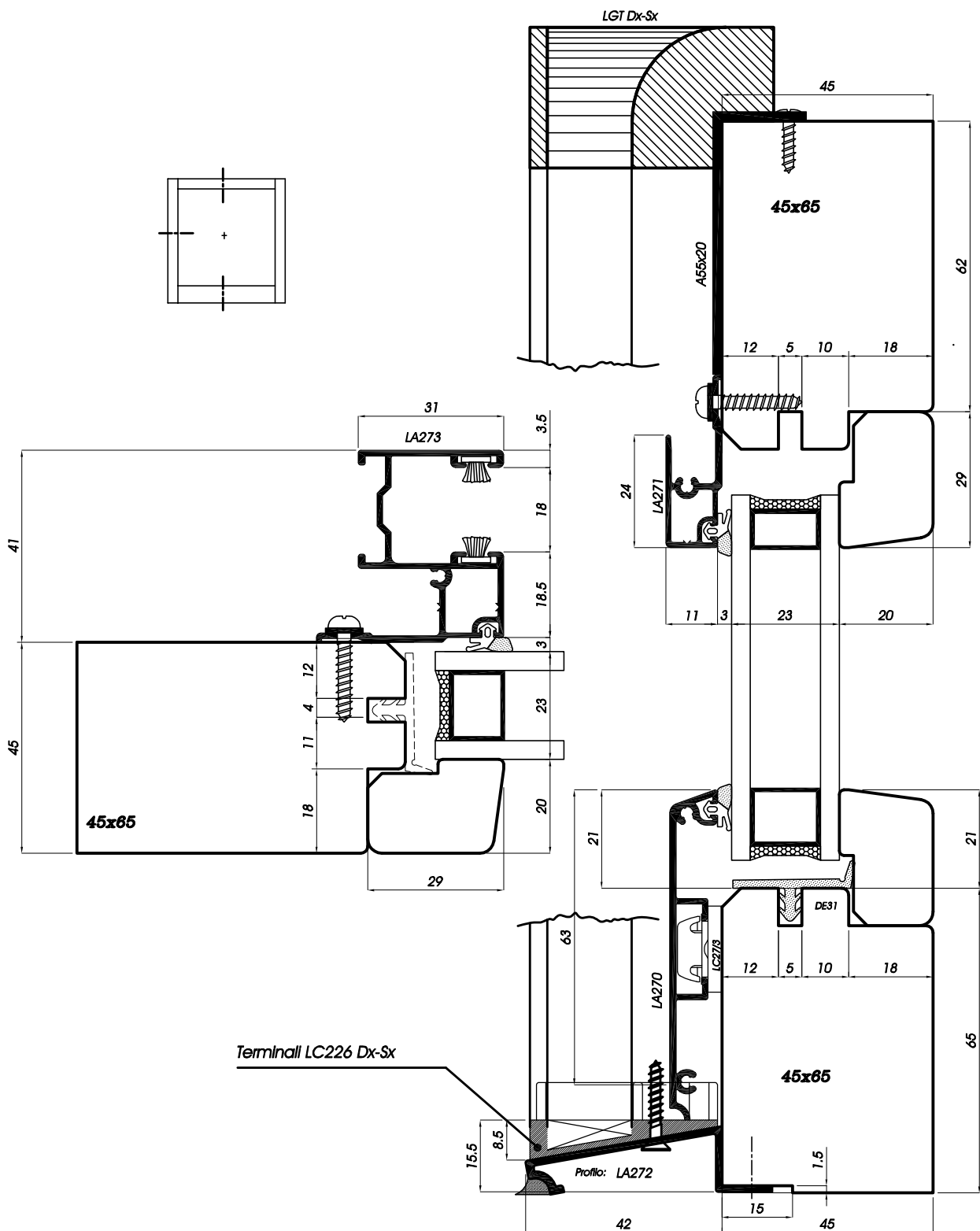

Sezione orizzontale e verticale finestra con vetro fisso con avvolgibile  
 Horizontal- und Vertikalschnitt Fenster Fixverglasung mit Rolladenführung  
 Sección horizontal y vertical ventana con cristal fijo con guía de persiana  
 Coupe horizontale et verticale fenêtre avec vitre fixe et coulisse volet roulant  
 Horizontal and vertical window wit fixed glass and turning guide

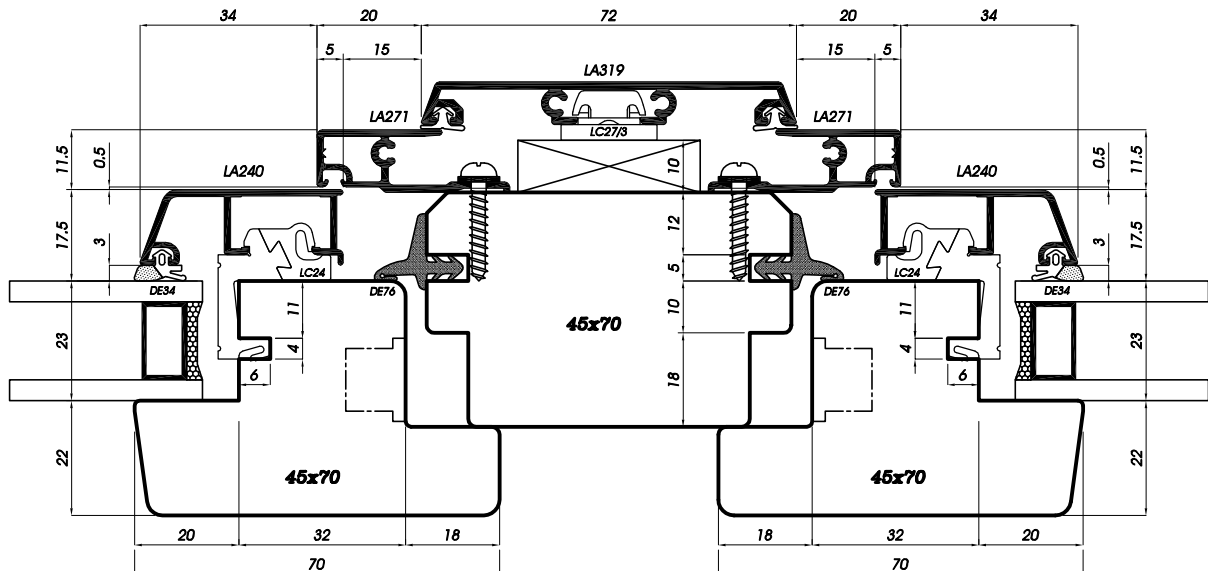
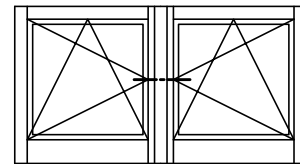
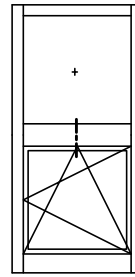
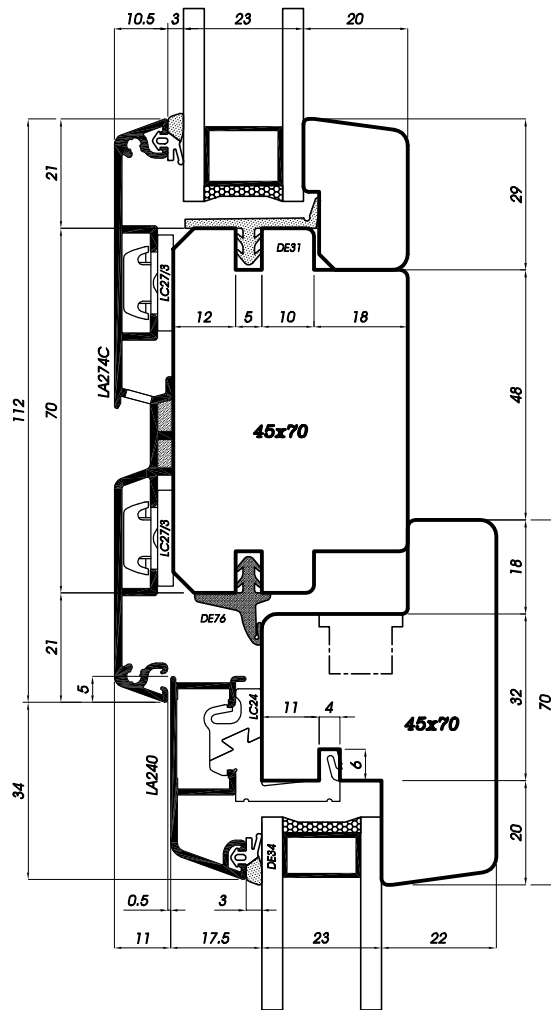

Sezione orizzontale e verticale traversi intermedi telaio  
 Horizontal- und Vertikalschnitt Rahmensprossen  
 Sección horizontal y vertical travesaños intermedios del marco  
 Coupe horizontale et verticale des traverses intermédiaires du dormant  
 Horizontal and vertical section of the frame's middle ledger

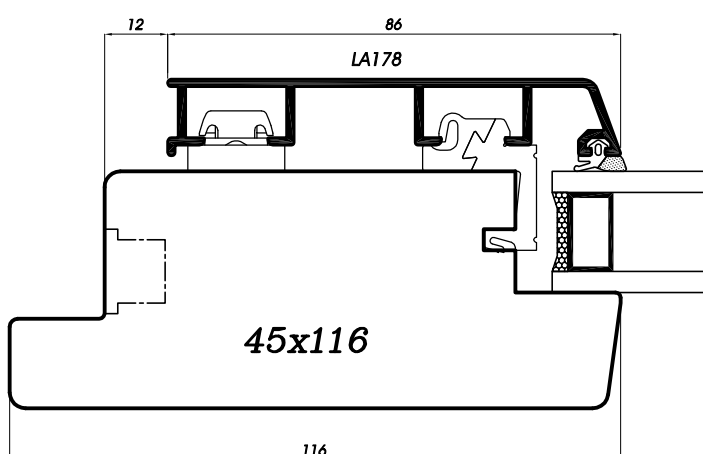
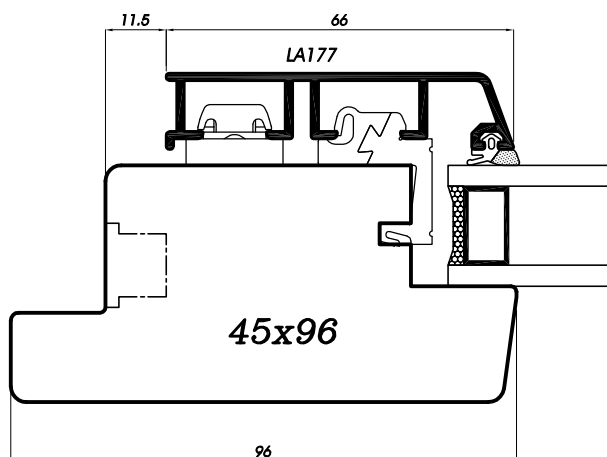
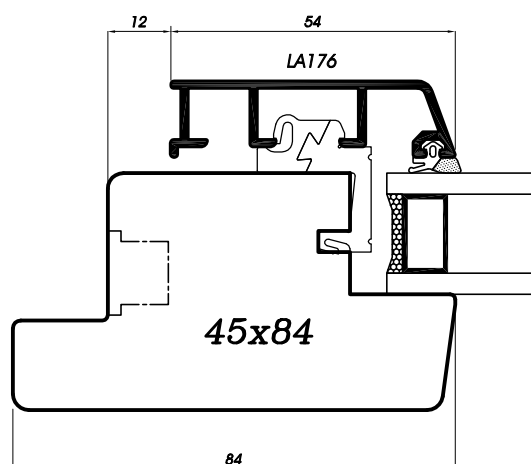
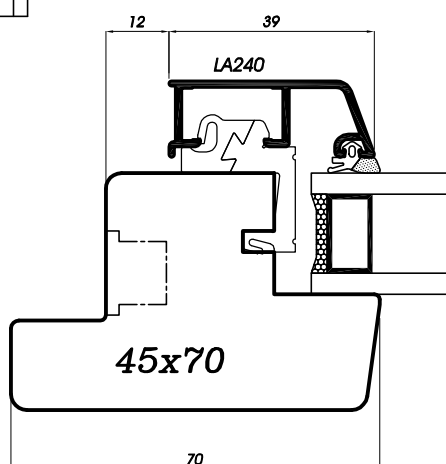
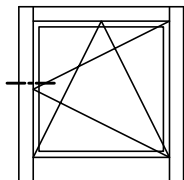

**Sezioni orizzontali battenti**  
**Horizontalschnitt Flügel**  
**Secciones horizontales hojas**  
**Coupes horizontales vantaux**  
**Wings' horizontal section**

**LA270**  
traverso sotto

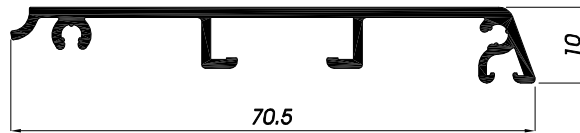

**LA271**  
Montanti + superiore

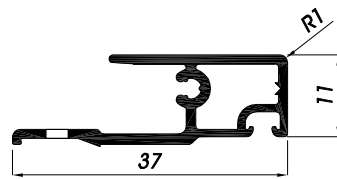

**LA273**  
Montanti

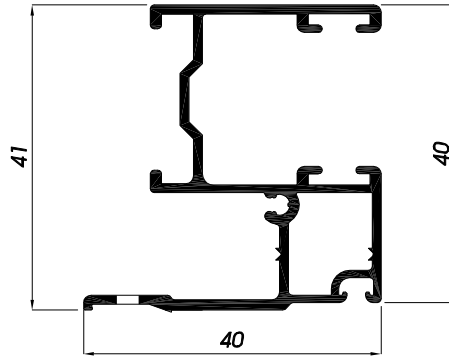

**LA272**  
Grondalino

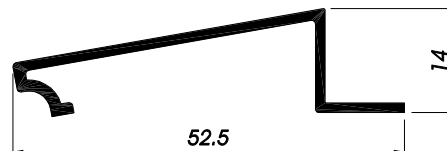

**LA286**  
Grondalino

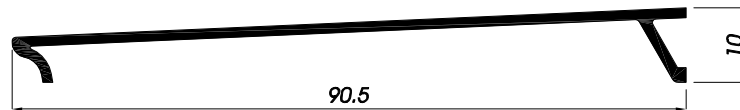

**LA274C**  
con asole per scarico acqua

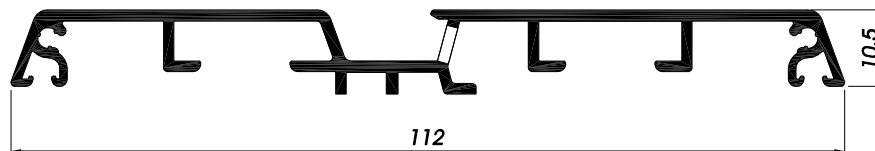

**LA285**  
Guida +  
zanzariera

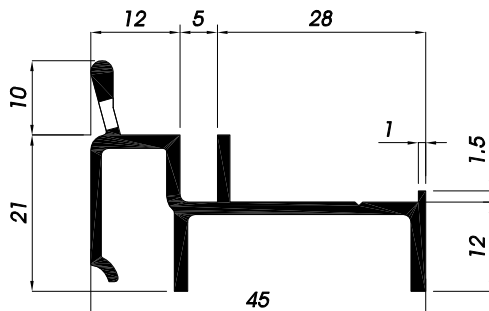
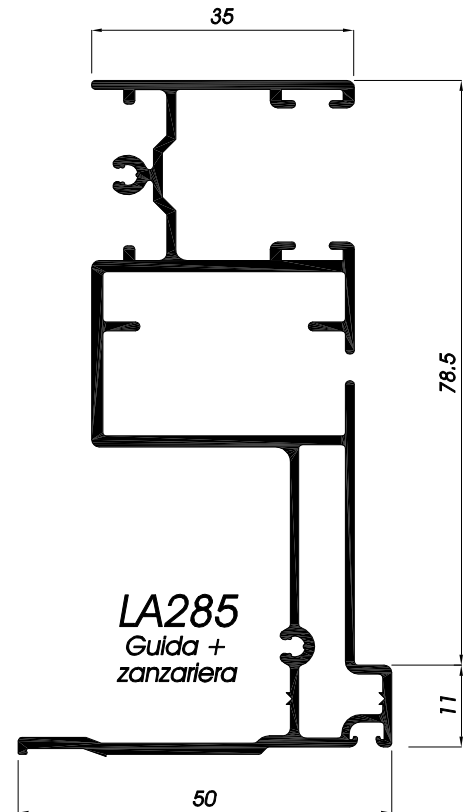

**PA216**  
soglia 31mm

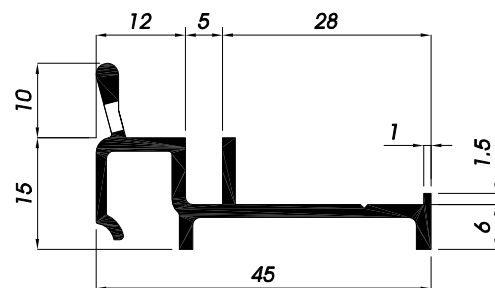

**PA220**  
soglia 25mm

Profili in alluminio  
Aluminiumprofile  
Perfiles de aluminio  
Profils en aluminium  
Aliminum profiles

**SCHEMA DI FORATURA TELAIO IN ALLUMINIO SU SISTEMA LIGHT/45 SENZA GUIDA PER AVVOLGIBILE**

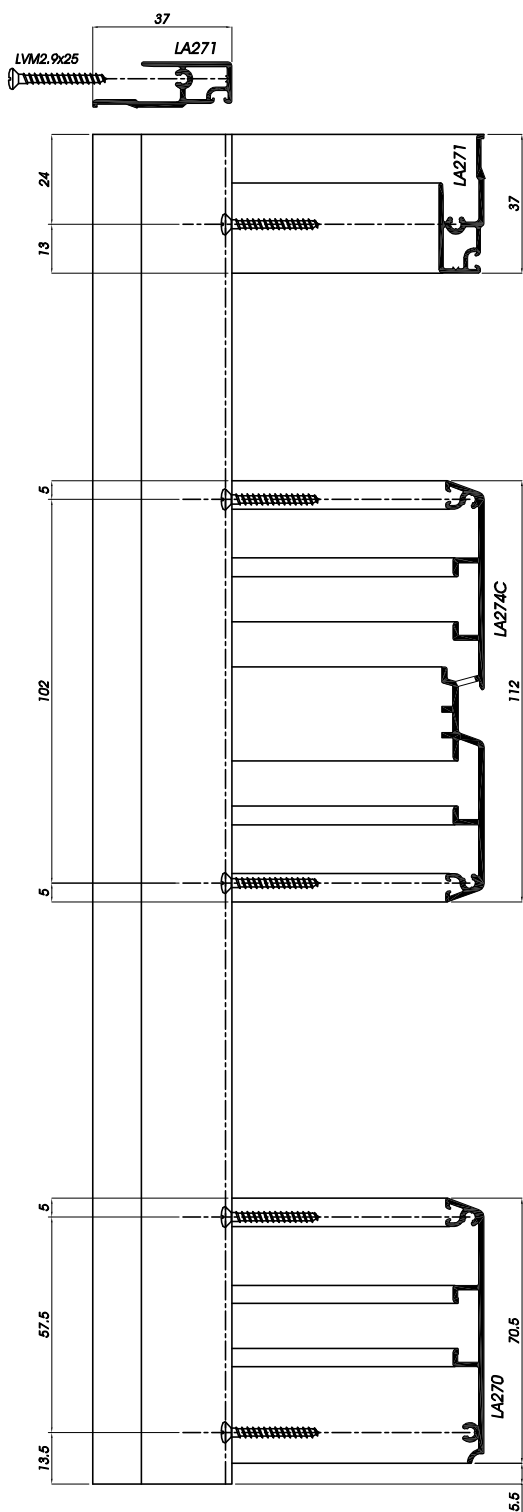

**SCHEMA DI FORATURA TELAIO IN ALLUMINIO SU SISTEMA LIGHT/45 CON GUIDA PER AVVOLGIBILE**

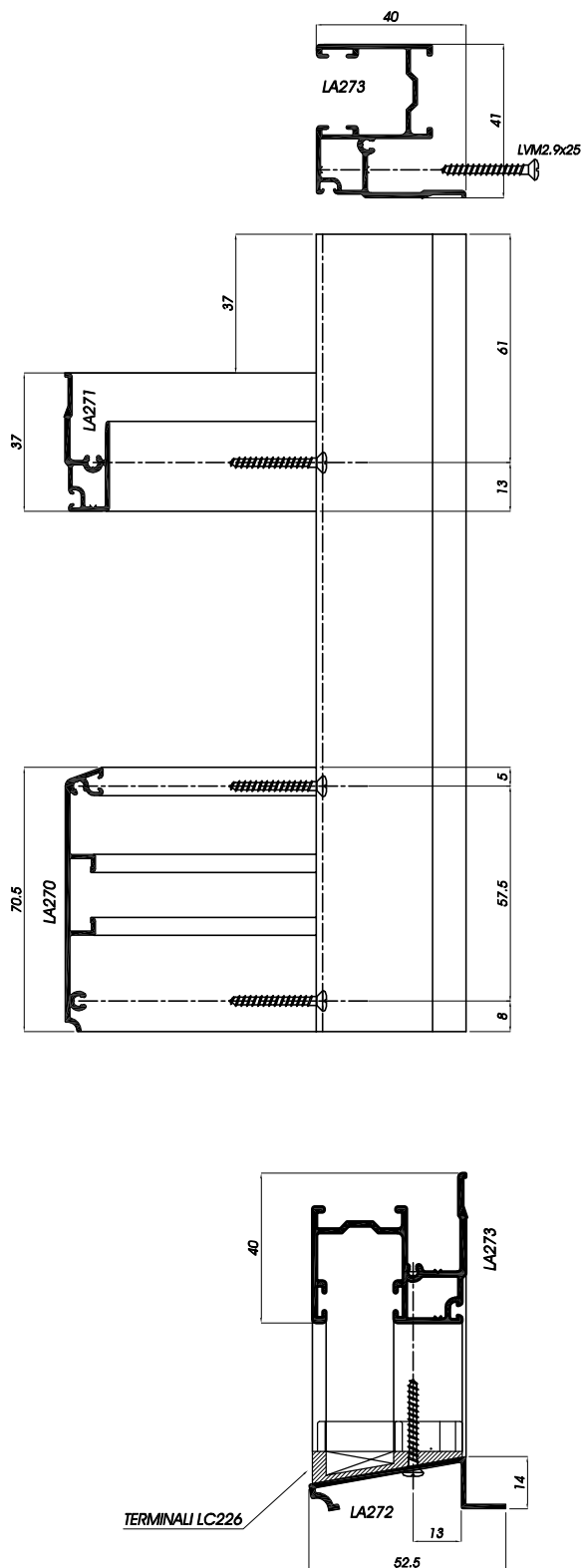

**Schema di foratura profili telaio**  
**Zeichnung für Bohrung Rahmenprofile**  
**Esquema para taladrar los perfiles del marco**  
**Schéma de perçage des profils du dormant**  
**Drilling's scheme for the frame's profiles**



**SCHEMA DI FORATURA PROFILI PER  
SISTEMA MONBLOCCO LIGHT/45**

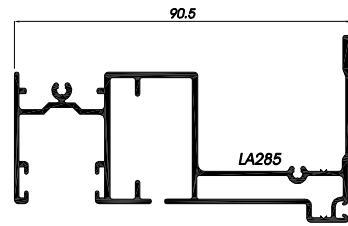
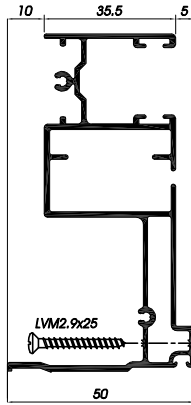

LAVORAZIONE DI INVITO  
TELO ZANZARIERA

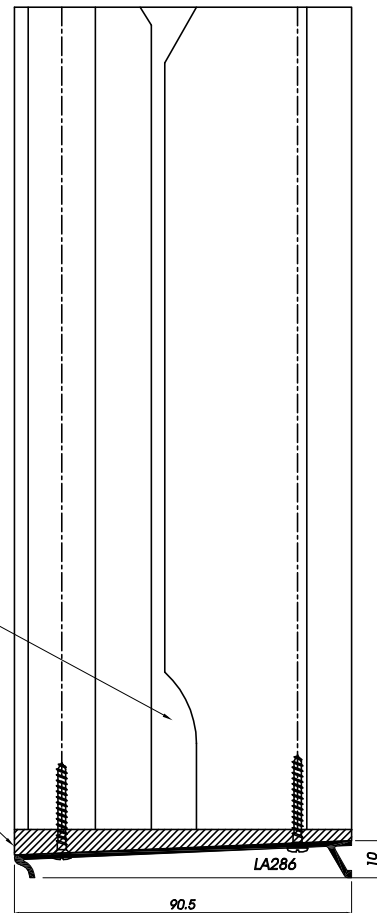
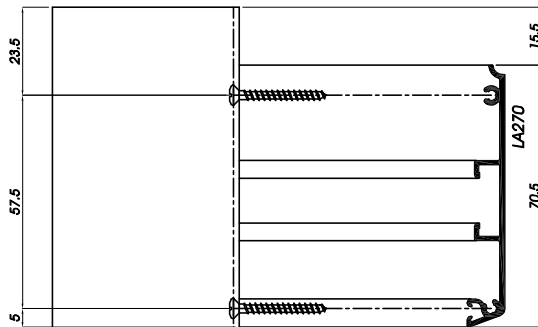

LAVORAZIONE PER AGGANCIO  
MANIGLIA ZANZARIERA

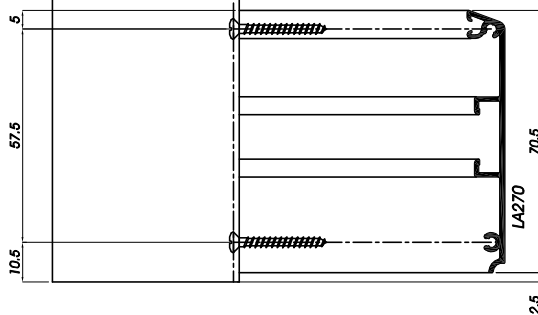

**Schema di foratura profilo LA285 per monoblocco**  
**Bohrung Profil LA285 für Rolladenkasten**  
**Esquema para taladrar el perfil de monoblock LA285**  
**Schéma de perçage du profil LA285 pour fenêtre monobloc**  
**Drilling's scheme of the profile LA 285 for enbloc**

# ACCESSORI – GUARNIZIONI – TERMINALI

**LC319/45**

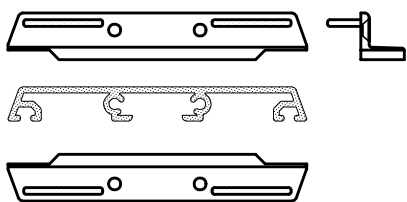

TERMINALI  
PER PROFILO LA319

**LC180 Dx-Sx**

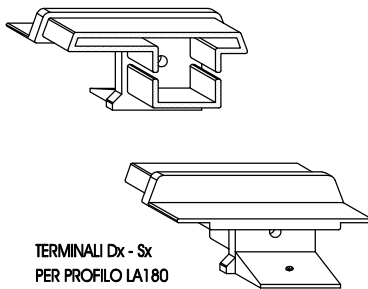

TERMINALI Dx - Sx  
PER PROFILO LA180

**DE76**

Guarnizione telaio  
Materiale: EPDM Colore: NERO

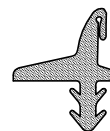

**DE31**

Guarnizione per fisso  
Materiale: EPDM Colore: NERO

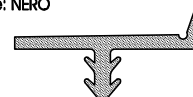

**LC226 Dx-Sx**

TERMINALI Dx - Sx  
PER PROFILO LA226 - LA273

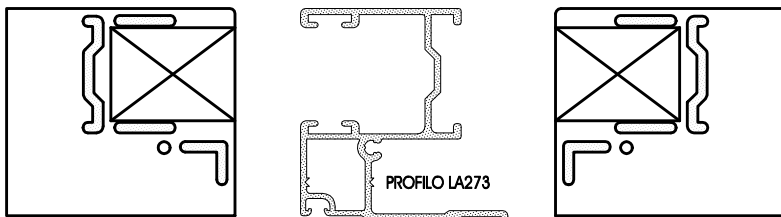

PROFILO LA273

**LVM 2.9x25**

Vite per accoppiamento  
profilo telaio

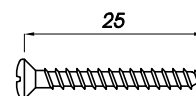

**LC285 Dx-Sx**

TERMINALI Dx - Sx  
PER PROFILO LA285

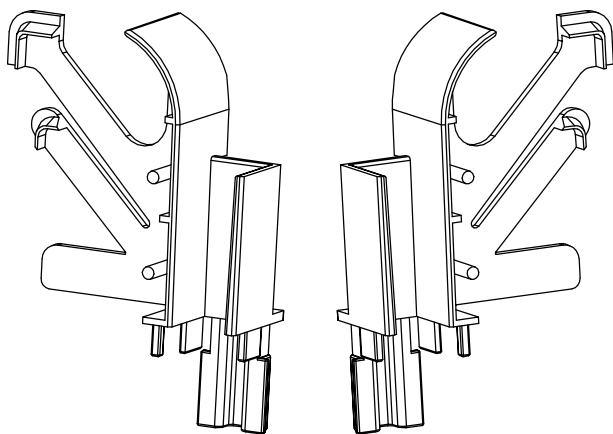

**LC286 Dx-Sx**

TERMINALI Dx - Sx  
PER PROFILO LA286

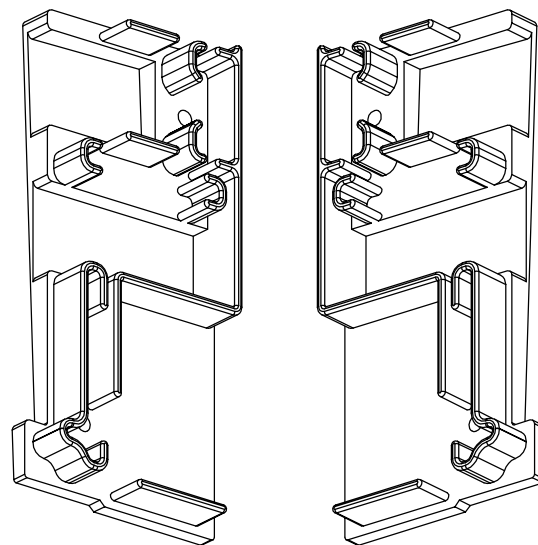

**Terminali per profili**  
**Stulpkappen für profile**  
**Terminales para perfil**  
**Embouts pour profils**  
**Terminals for profiles**

*SCORREVOLE MEDITERRANEO IN LEGNO-ALLUMINIO*

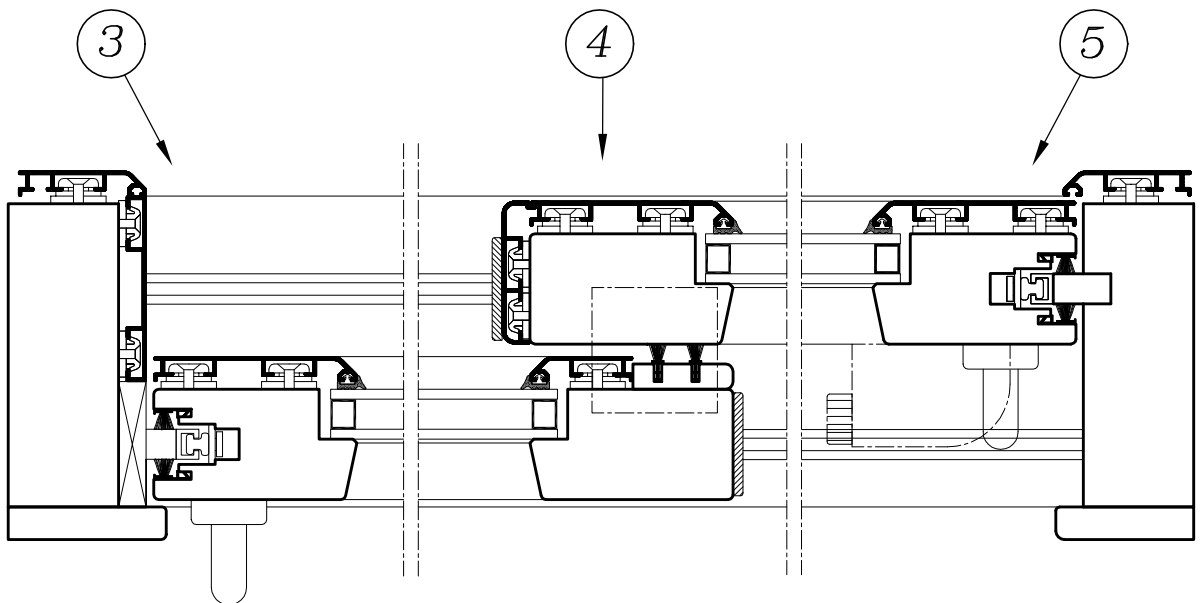
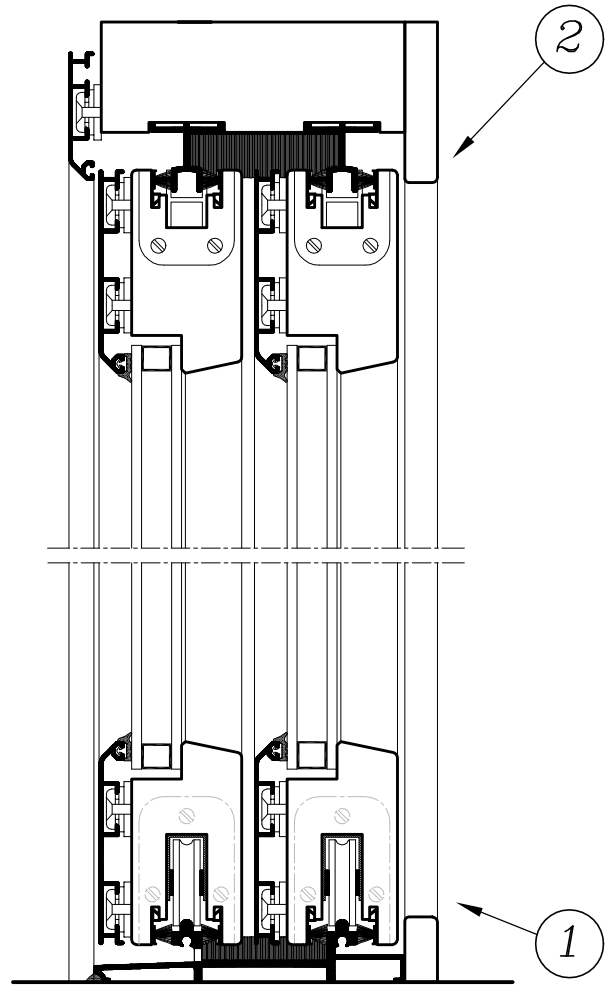

Sezione anta  
montante laterale

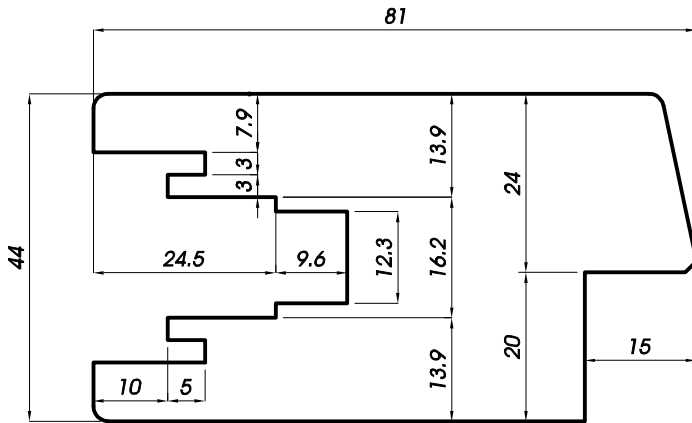

Sezione anta  
traverso superiore

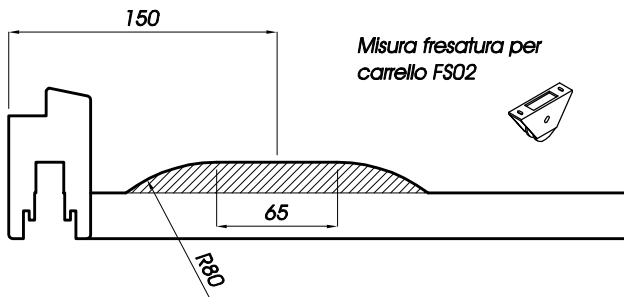
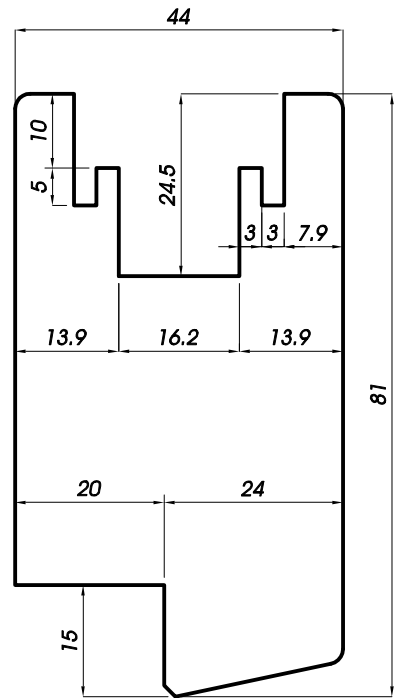

Quote modificate per  
fresatura dell'incastro  
dei carrelli FS02 e FS03

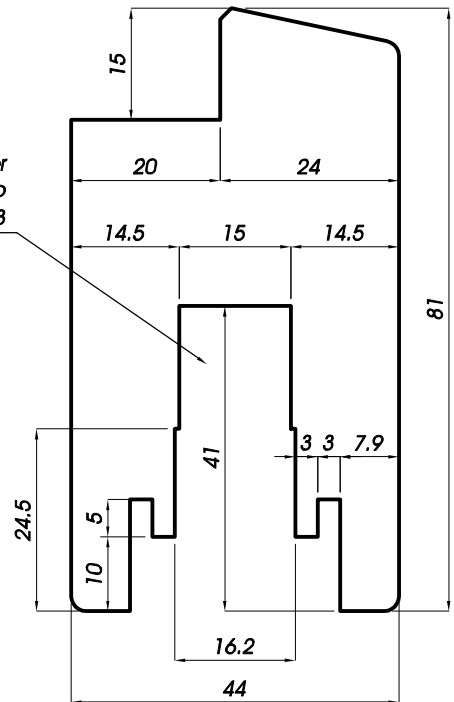
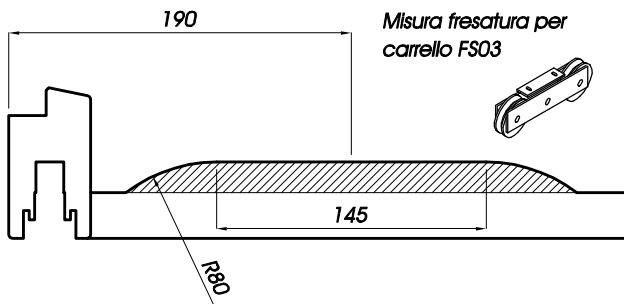

Sezione anta  
traverso inferiore

Sezioni ante  
Flügelsschnitte  
Secciones hojas  
Sections vantaux  
Wings' section

**SEZIONE -1-**

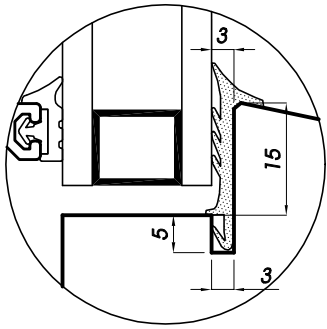

**DR01/15**

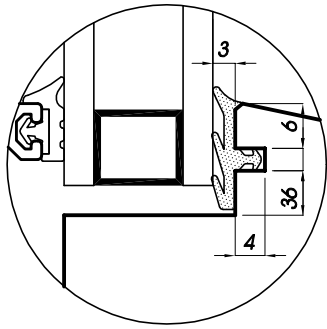

**DE23**

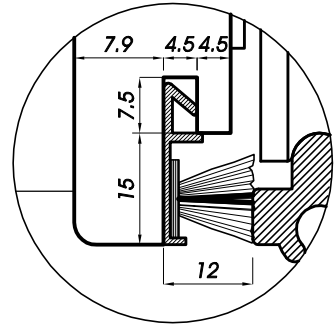

**DE36**

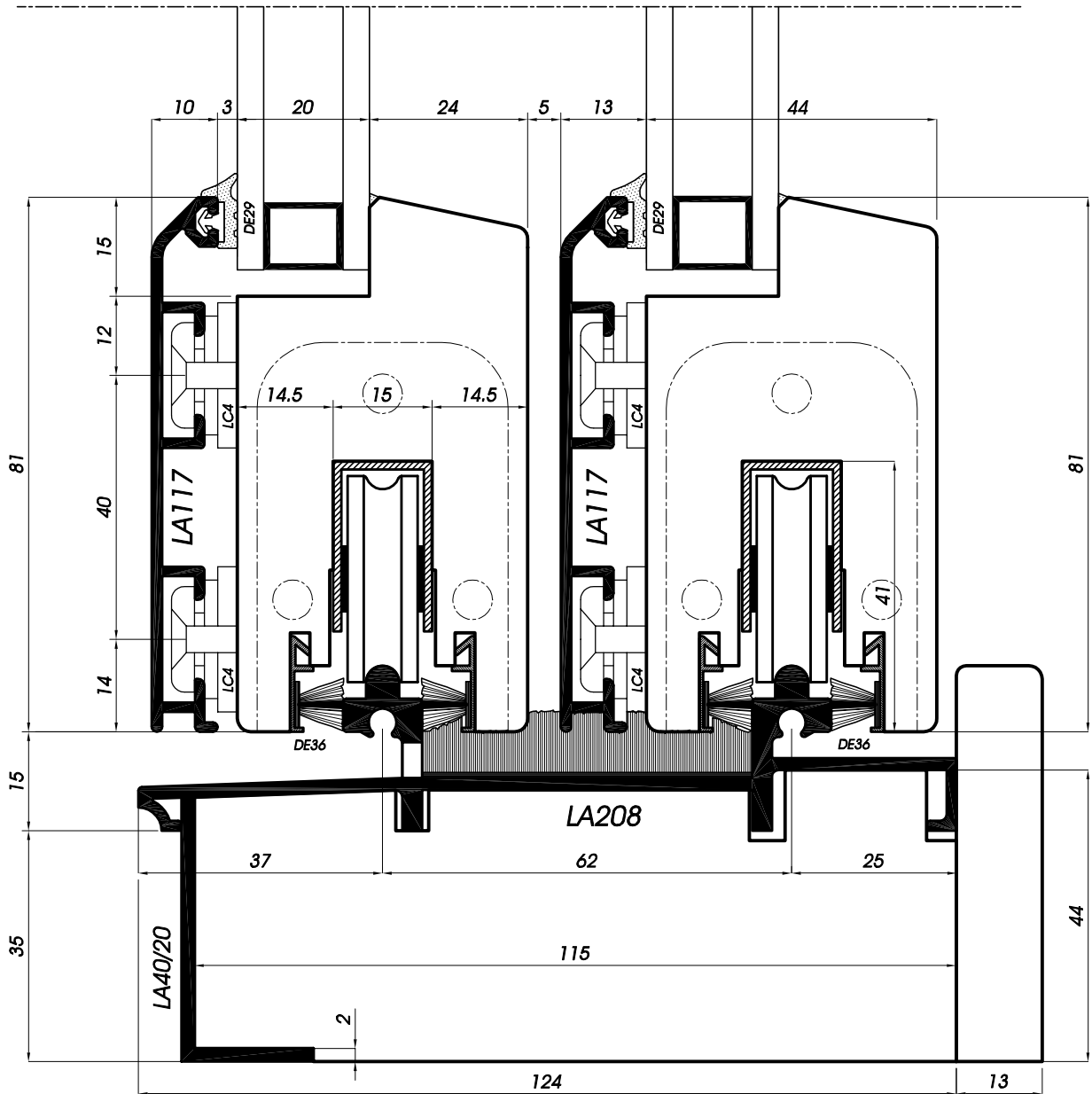

*Sezione verticale traverso inferiore finestra scorrevole  
 Vertikalschnitt Schiebefenster quer unten  
 Sección vertical travesaño inferior de ventana corredera  
 Section verticale traverse inférieure fenêtr coulissante  
 Vertical section of the sliding window's lower ledger*

SEZIONE -1a-

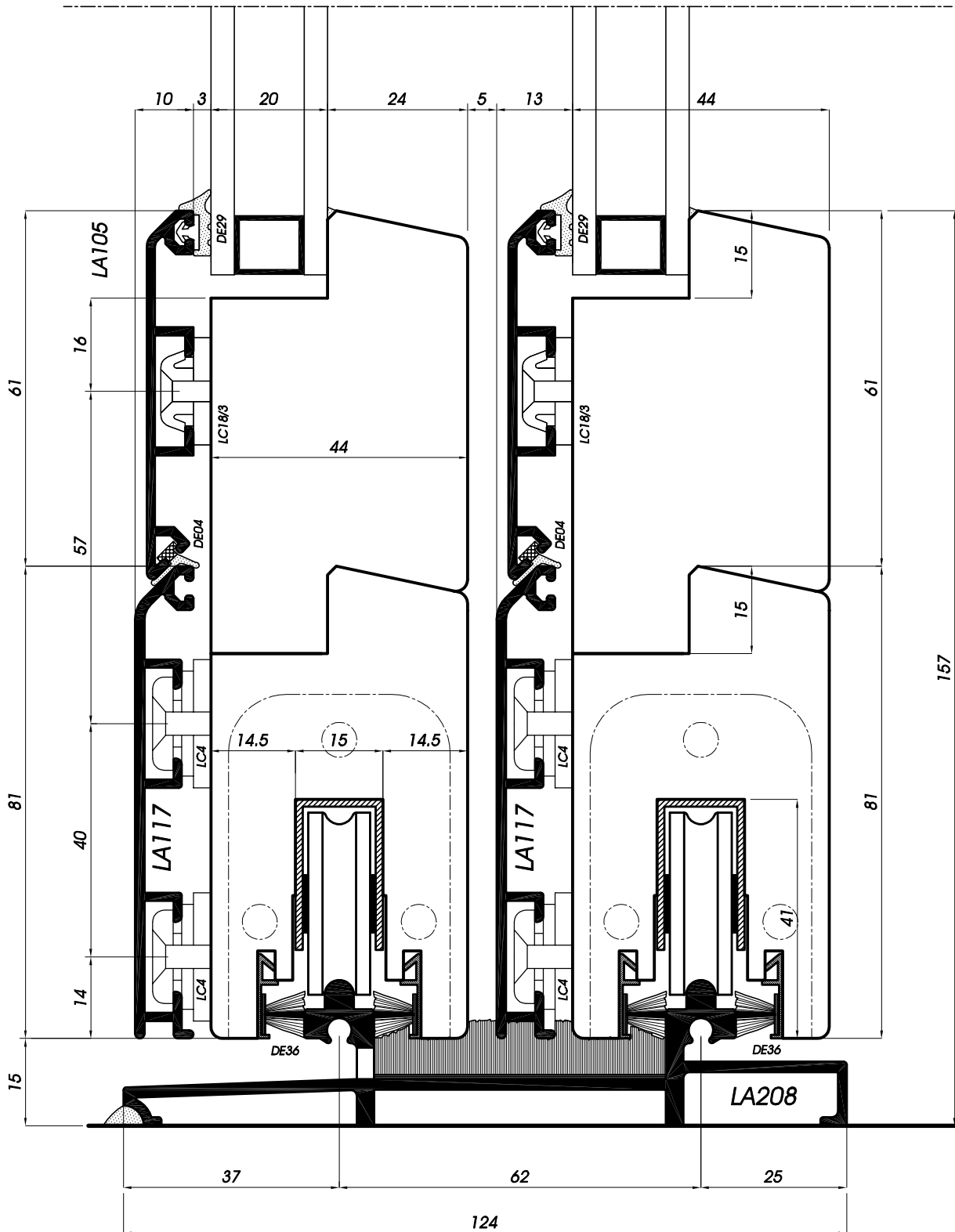

Sezione verticale traverso inferiore portafinestra scorrevole  
 Vertikalschnitt Schiebetür quer unten  
 Sección vertical travesaño inferior de puertaventana corredera  
 Coupe verticale traverse inférieure porte-fenêtre coulissante  
 Vertical section of the sliding window-door's lower ledge

SEZIONE -2-

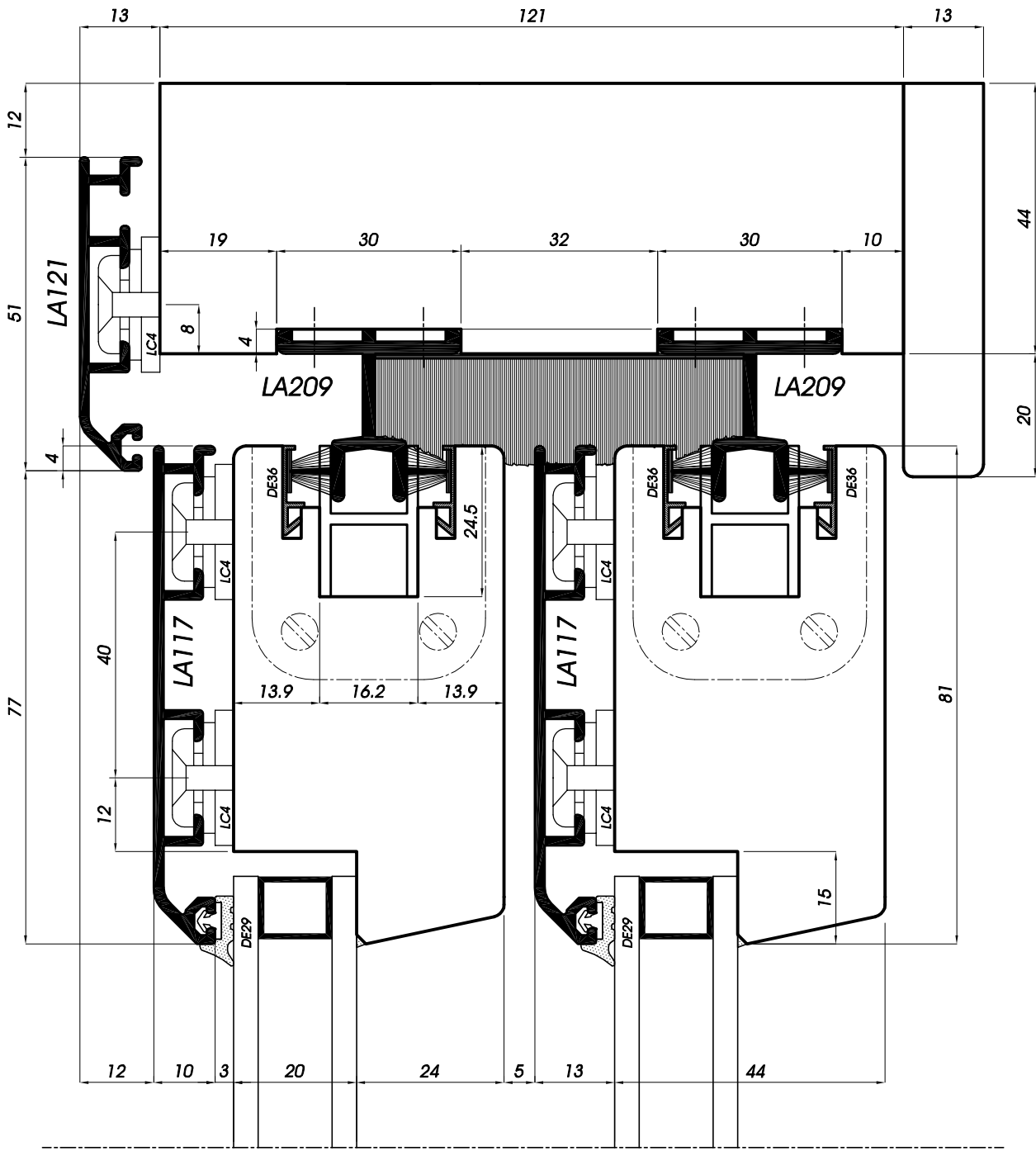

*Sezione verticale traverso superiore finestra scorrevole*  
*Vertikalschnitt Schiebefenster quer oben*  
*Sección vertical travesaño superior de ventana corredera*  
*Coupe verticale traverse supérieure fenêtre coulissante*  
*Vertical section of the sliding window-door's upper ledge*

SEZIONE -3-

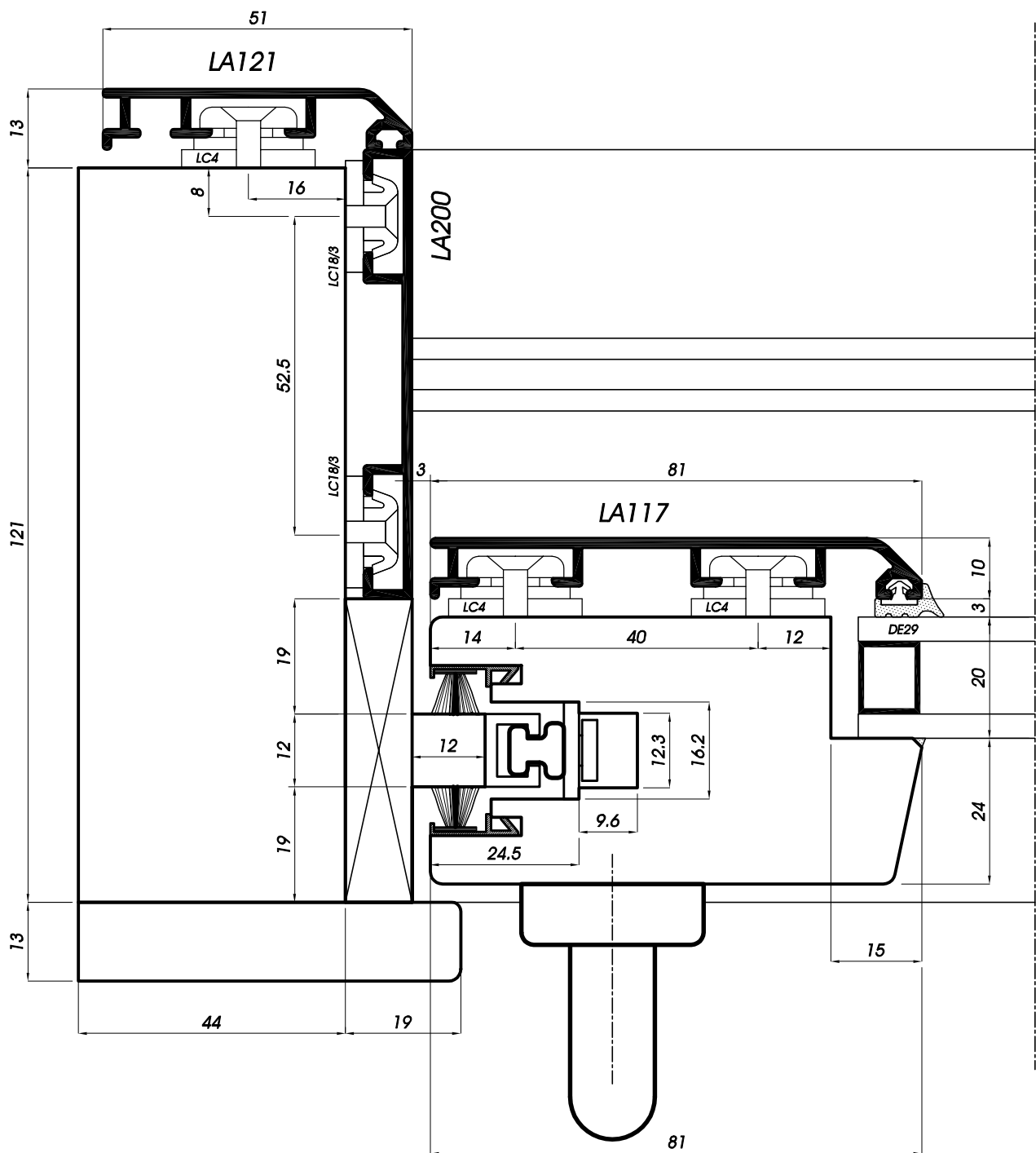

*Sezione orizzontale montante laterale sinistro finestra scorrevole*  
*Horizontalschnitt senkrecht seitlich links Schiebe-Fenster*  
*Sección horizontal montante lateral izquierdo de ventana corredera*  
*Coupe horizontale montant latéral gauche fenêtre coulissante*  
*Horizontal section of the sliding window-door's left lateral jamb*



SEZIONE -4-

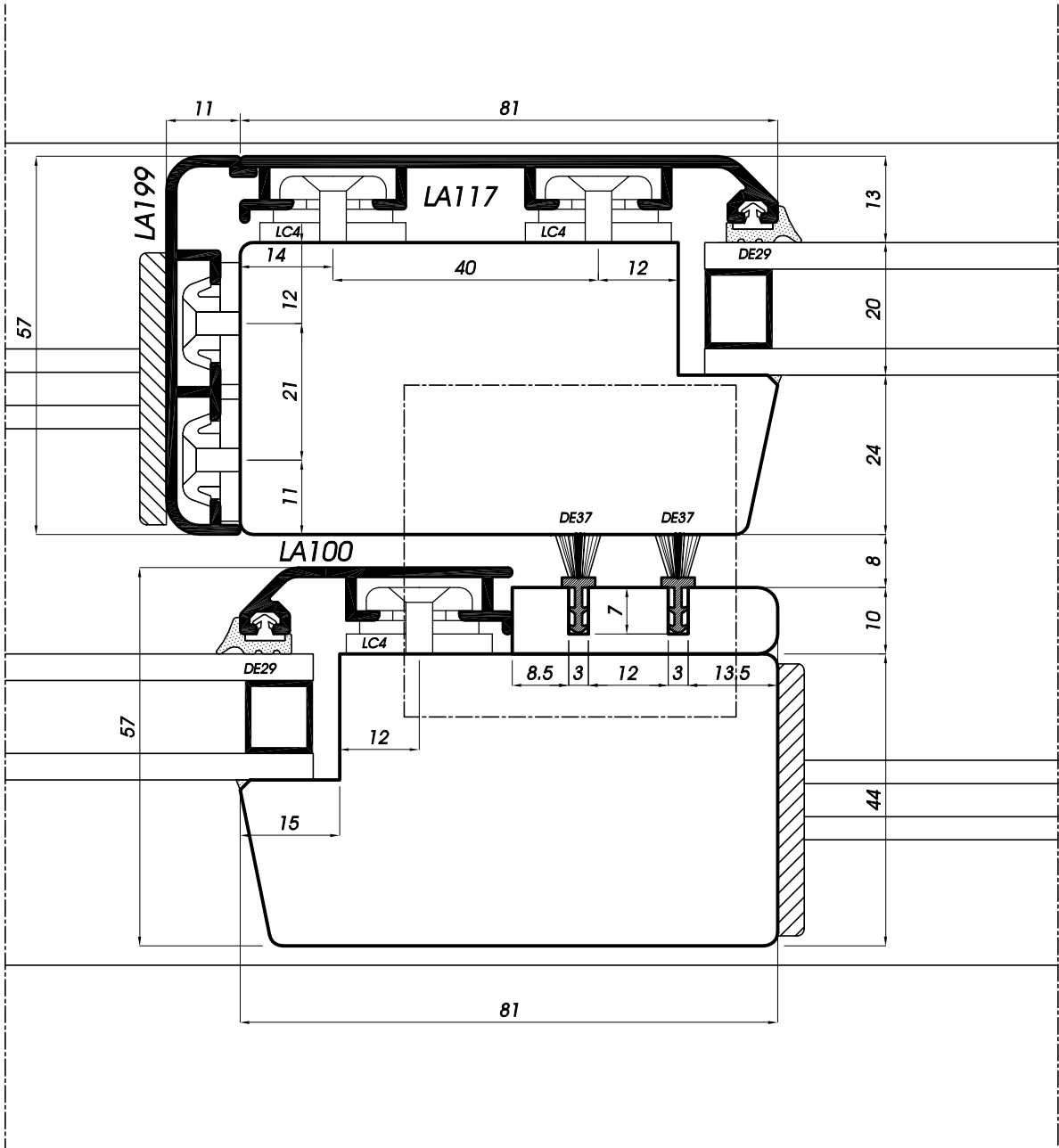

*Sezione orizzontale chiusura centrale finestra scorrevole*  
*Horizontalschnitt Stulpprofil Schiebefenster*  
*Sección horizontal del cierre central de ventana corredera*  
*Coupe horizontale battement central fenêtre coulissante*  
*Horizontal section of the sliding window-door's middle clamp*

SEZIONE -5-

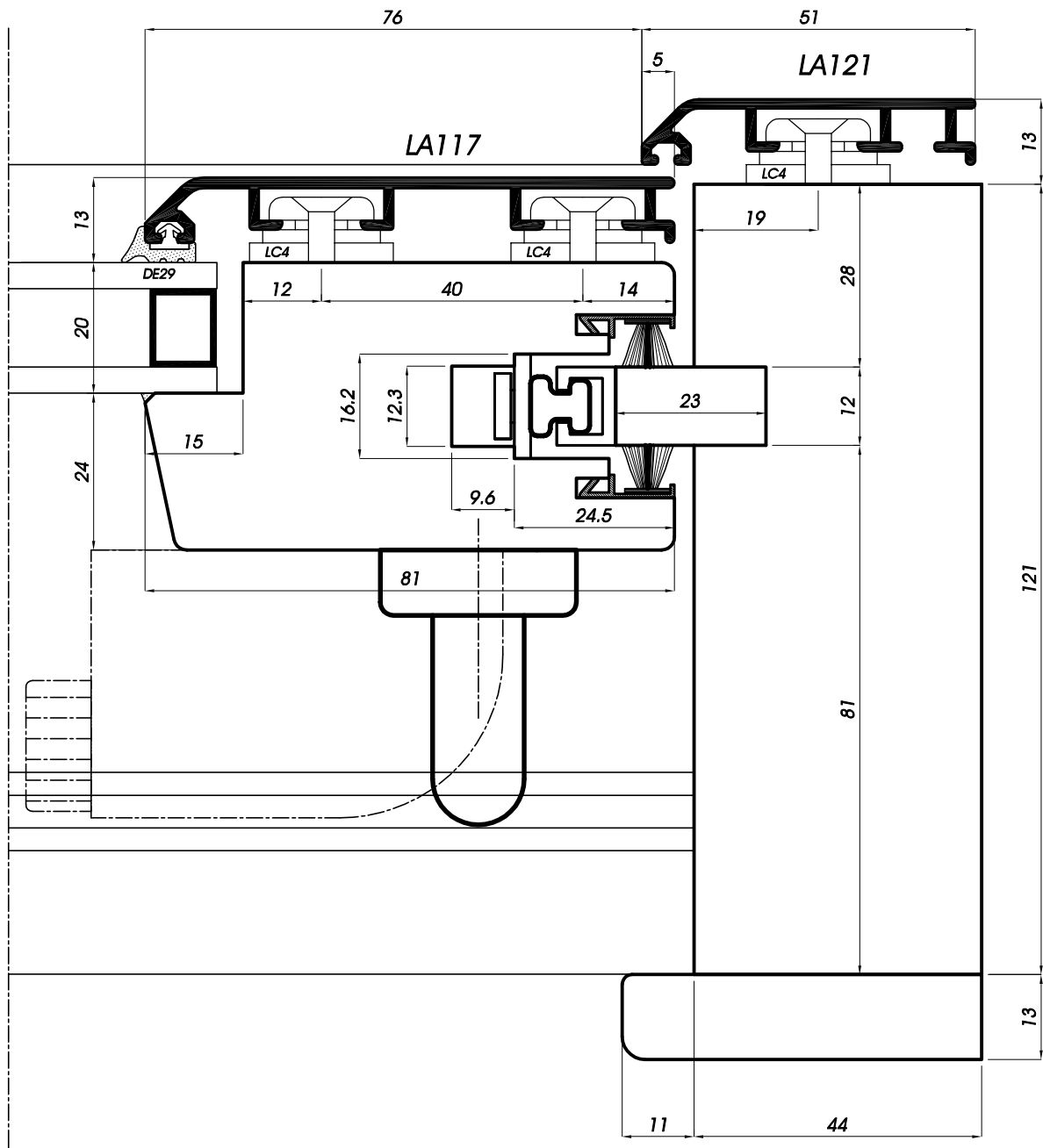

*Sezione orizzontale montante laterale destro finestra scorrevole*  
*Horizontalschnitt senkrecht seitlich rechts Schiebe-Fenster*  
*Sección horizontal montante lateral derecho de ventana corredera*  
*Coupe horizontale montant latéral droit fenêtre coulissante*  
*Horizontal section of the sliding window-door's right lateral jamb*

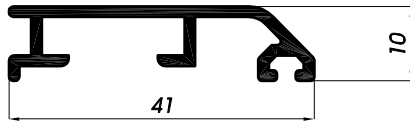

L=41mm LA100

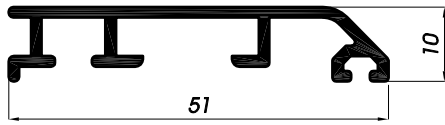

L=51mm LA121

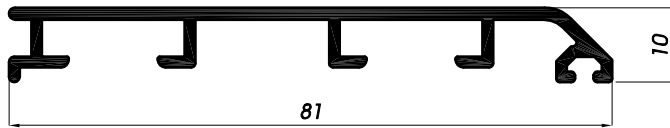

L=81mm LA117

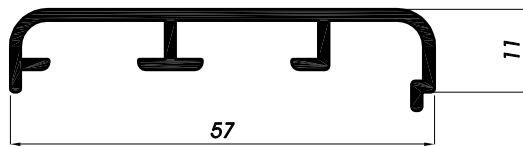

L=57mm LA199



L=74mm LA200

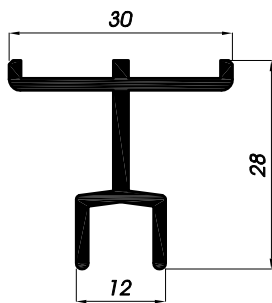

LA209

L=124mm LA208

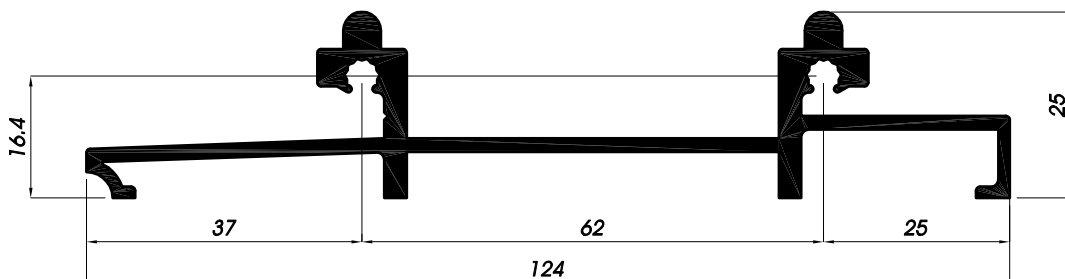

Profili in alluminio  
Aluminiumprofile  
Perfiles de aluminio  
Profils en aluminium  
Aluminum profiles

# **-FS01/KIT- ACCESSORI PER SCORREVOLE MEDITERRANEO**

*KIT di accessori art. FS01/KIT- composto dai seguenti elementi:*

- Terminali di guida A (n°2 pezzi) colore nero
- Terminali di guida B (n°2 pezzi) colore nero
- Piastrina di copertura C (n°2 pezzi) colore nero
- Tampone superiore D (n°1 pezzo) colore nero
- Tampone inferiore E (n°1 pezzo) colore nero

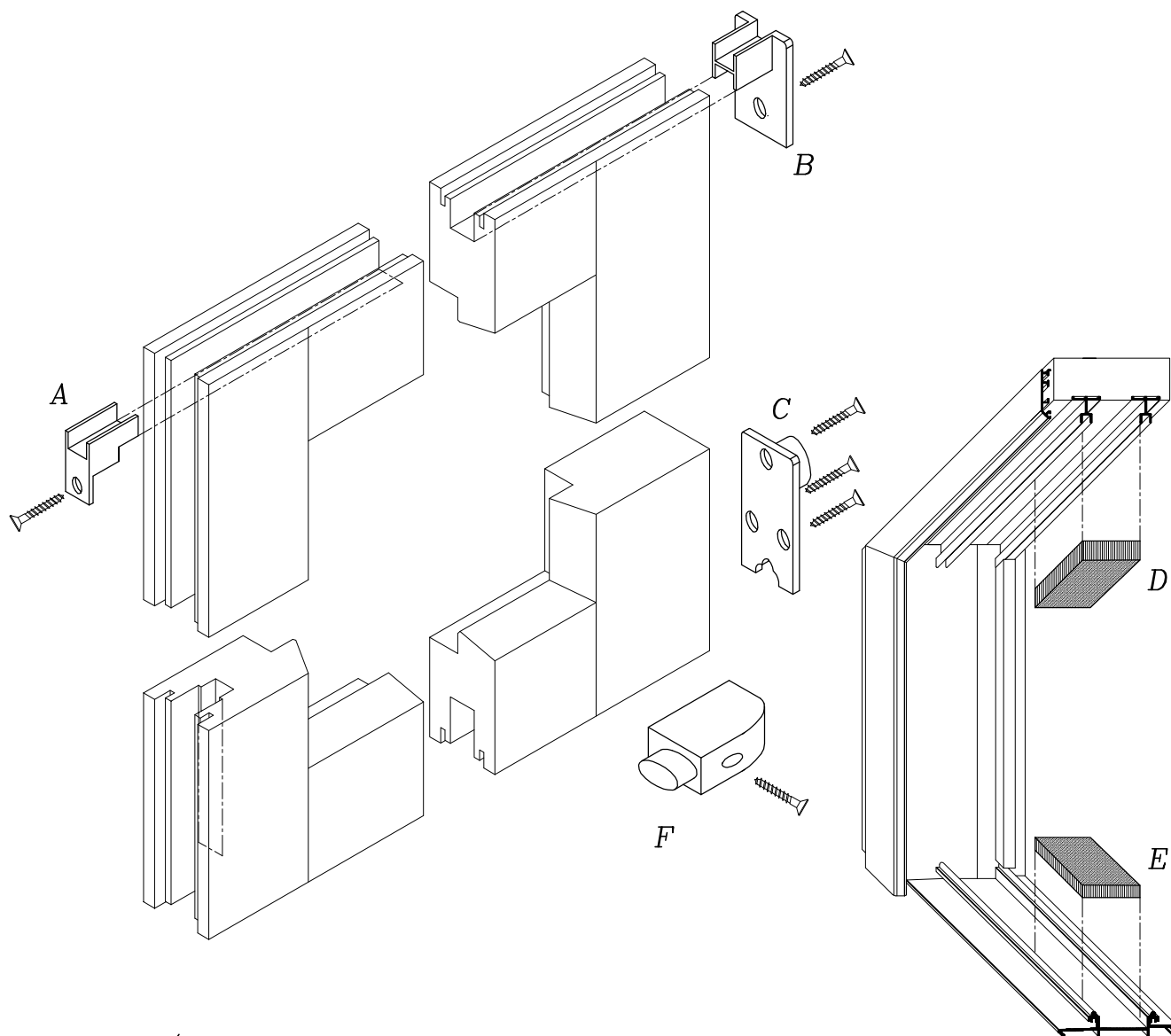

*FS07/N Paracolpo 90° F (n°1 pezzo) colore nero*

*FS07/B Paracolpo 90° F (n°1 pezzo) colore bianco*

**Accessori - FS01 - Kit**  
**Zubehör - FS01 - Kit**  
**Accesorios - FS01 - Kit**  
**Accessoires - FS01 - Kit**  
**Spare parts**

# FERRAMENTA PER SCORREVOLE MEDITERRANEO

## CARRELLI:

Art. FS02-Carrello a una ruota Ø32mm -Portata 80kg

Art. FS03-Carrello a due ruote Ø32mm -Portata 150kg

## CREMONESI entrata 15:

Articolo	Lunghezza	Scontri	Perno antisollevamento	H. maniglia
FS04/600	600mm	2	1	300mm
FS04/1000	1000mm	2	1	500mm
FS04/1600	1600mm	2	1	800mm
FS04/1800	1800mm	3	1	900mm

## MANIGLIA:

Art. FS05/1-Maniglia DIRIGENT con 2 viti M5x40 Finitura ARGENTO

Art. FS05/5-Maniglia DIRIGENT con 2 viti M5x40 Finitura Elettr. BRONZO scuro

Art. FS05/7-Maniglia DIRIGENT con 2 viti M5x40 Finitura BIANCO RAL9016

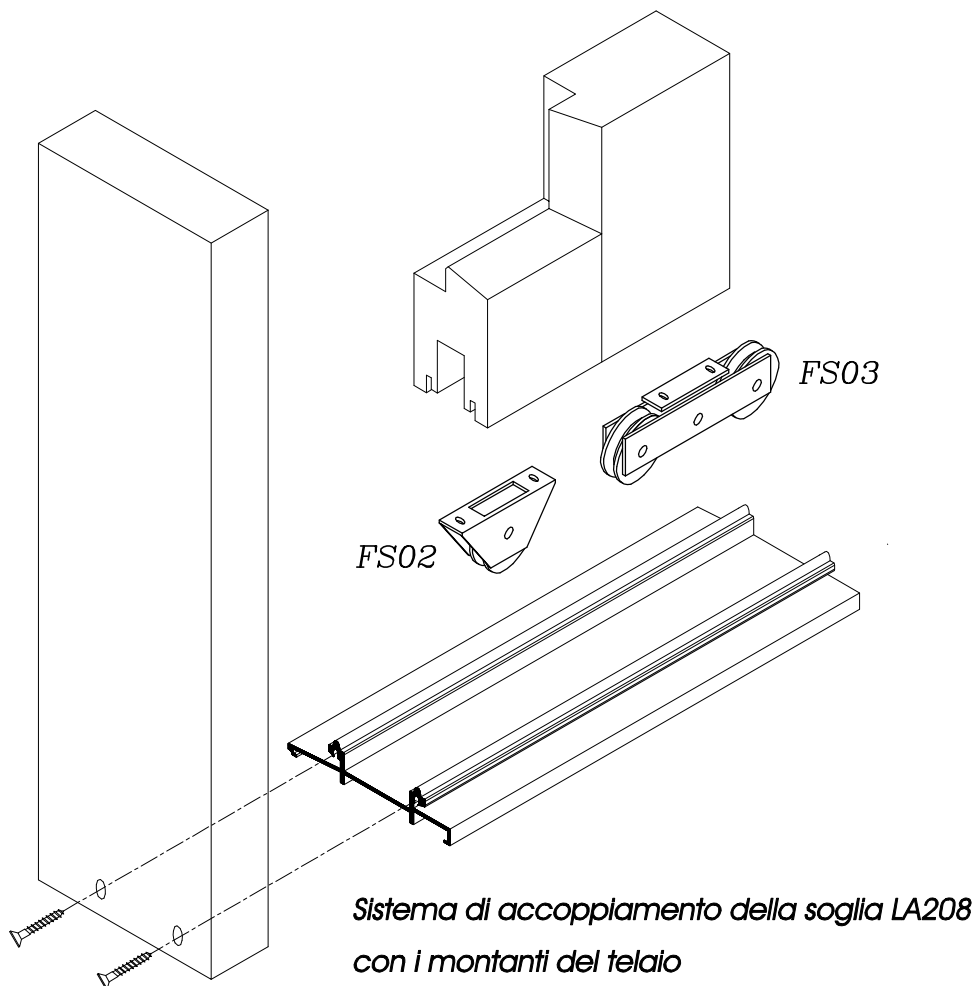

**Ferramenta per finestra scorrevole**  
**Beschläge für Schiebe-Fenster**  
**Herraje para ventana corredera**  
**Quincaillerie pour fenêtre coulissante**  
**Hardware for the sliding window-door**

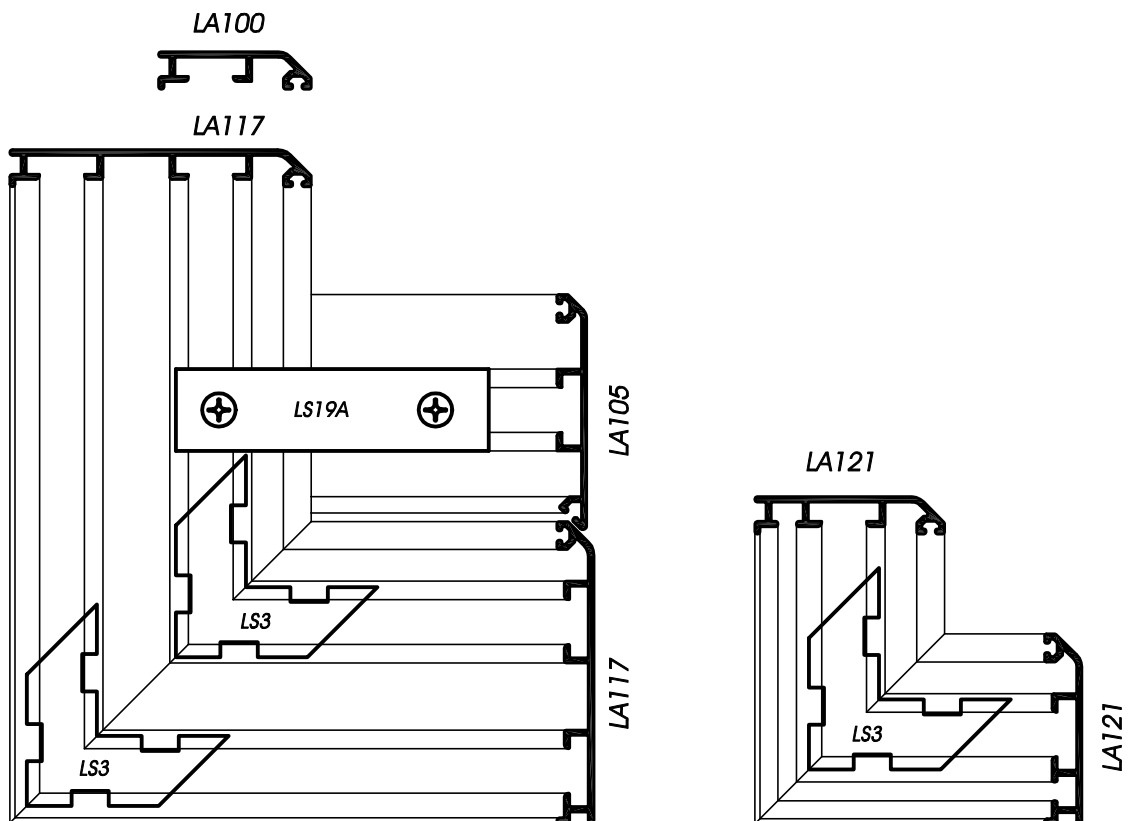
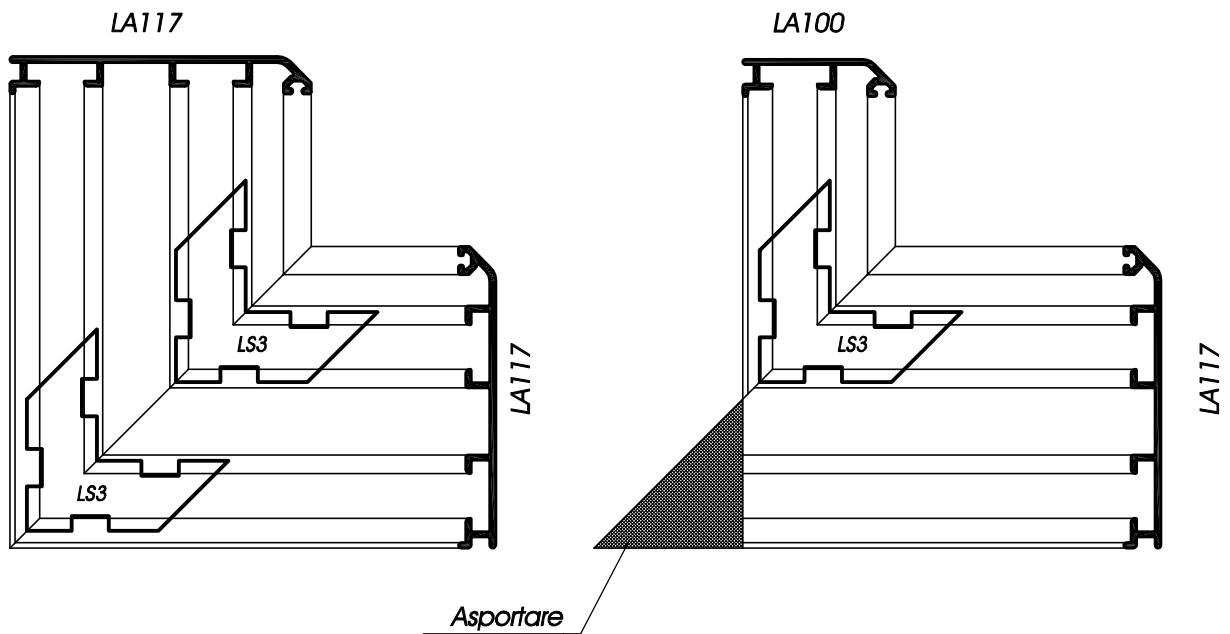

**Squadrette per profili finestra scorrevole**  
**Eckwinkel für Schiebe-Fenster**  
**Escuadras para perfiles de ventana corredera**  
**Equerres pour profils fenêtre coulissante**  
**Corner square for the profiles of the sliding window-door**

# INDICE DEI PROFILI LEGNO/ALLUMINIO

Codice	Pagina	Codice	Pagina	Codice	Pagina	Codice	Pagina
LA11	264	LA205	253	LA256	257	PA71	263
LA114	261	LA206	253	LA258	255	PA95	267
LA115	261	LA207	264	LA259	252	PA96	267
LA137	260	LA211	261	LA260	256	PA97	267
LA140	252	LA212	261	LA261	256	PA105	267
LA141	252	LA217	260	LA262	255	PA119	267
LA142	253	LA218	260	LA263	257	PA135T	263
LA143	253	LA220	253	LA264	257	PA136	263
LA144	262	LA222	252	LA265	252	PA137	263
LA145	253	LA223	253	LA267	256	PA151	268-269
LA146	253	LA224	253	LA268	256	PA152	268-269
LA147	252	LA226	264-265	LA269	257	PA153	268-269
LA148	264	LA227	256	LA279	259	PA154	268-269
LA149	252	LA228	256	LA280	259	PA155	268-269
LA157-15	262	LA229	256	LA281	259	PA156	268-269
LA157-18	262	LA230	255	LA282	262	PA156	269
LA157-19	262	LA231	255-262	LA283	256-262	PA164	268-269
LA161	261	LA232	255	LA284	262		
LA162	252	LA233	255	LA421	258	Piattine, angolari e tubolari	266
LA163	252	LA234	253	LA422	258		
LA169	264	LA236	256	LA423	258	Lamiere	266
LA174	264-265	LA238	259	LA427	257		
LA175	254	LA239	259	LA428	257	Accoppiamenti con squadrette	270
LA176	254	LA240	259	LA431	257		
LA177	254	LA241	256	LA445	258	Clips e accessori e terminali	288
LA178	254	LA242	259	LA446	258		
LA179	254	LA243	260	LA449	257	Guarnizioni e nastri di tenuta	292
LA180	254	LA244	260	LA450	258		
LA181	252	LA245	260	LA452	258		
LA182	264-265	LA246	260	LA453	258		
LA187	267	LA247	256	LA476	258		
LA189	254	LA248	256	LA477	258		
LA191	254-261	LA250	255	LA478	258		
LA198	260	LA251	264-265	LGT	265		
LA201	260	LA252	256	PA22	264-265		
LA202	260	LA253	254	PA68	263		
LA203	260	LA254	257	PA69	263		
LA204	254	LA255	255	PA70	263		

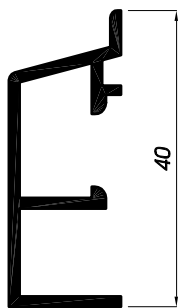

**LA162**  
Con terminale  
in gomma LC12A

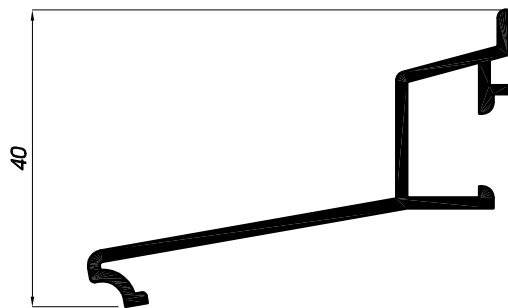

**LA163**  
Con terminale  
in gomma LC12A

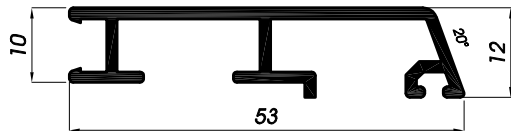

L=53mm

**LA149**

**LA149c**

con asole  
scarico acqua

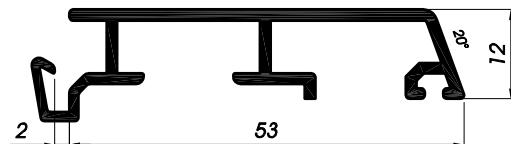

L=53mm

**LA259**

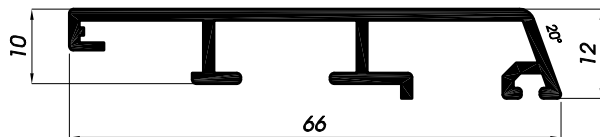

L=66mm

**LA140**

**LA140c**

con asole  
scarico acqua

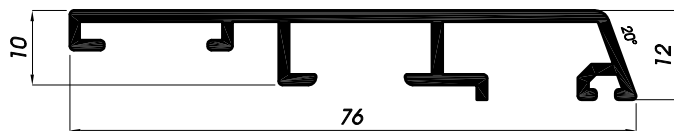

L=76mm

**LA265**

**LA265c**

con asole  
scarico acqua

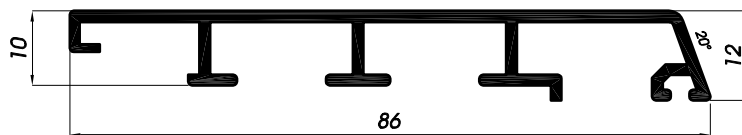

L=86mm

**LA141**

**LA141c**

con asole  
scarico acqua

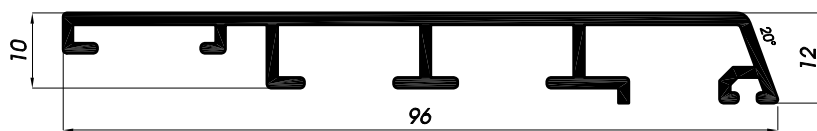

L=96mm

**LA222**

**LA222c**

con asole  
scarico acqua

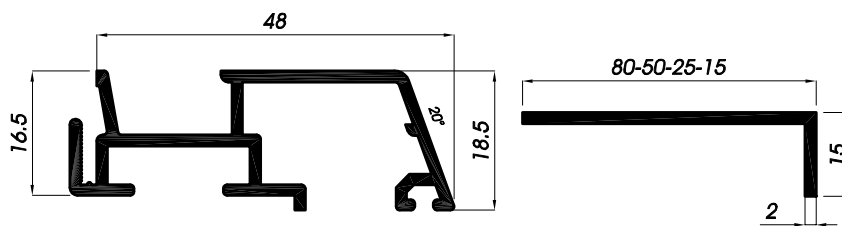

L=48mm

**LA147**

**LA147c**

con asole  
scarico acqua

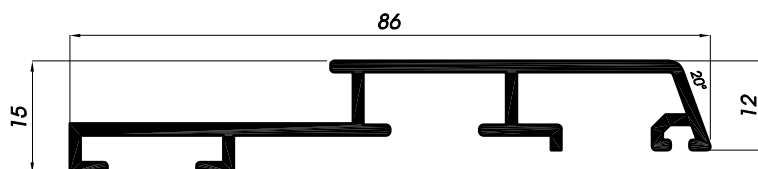

L=86mm

**LA181**

Profili in alluminio  
Aluminiumprofile  
Perfiles de aluminio  
Profils en aluminium  
Aluminium profiles



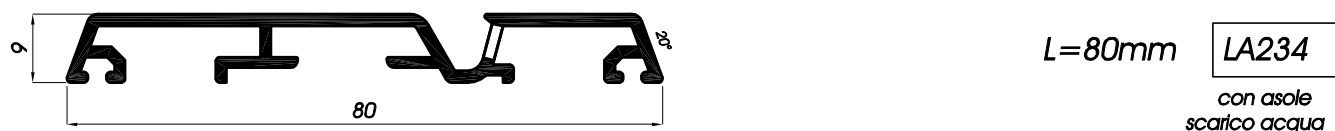
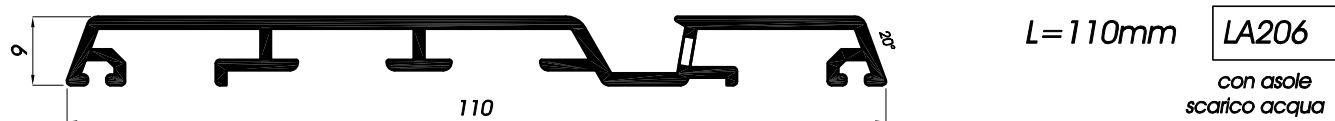
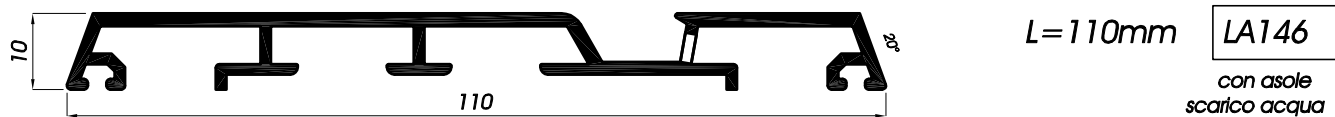
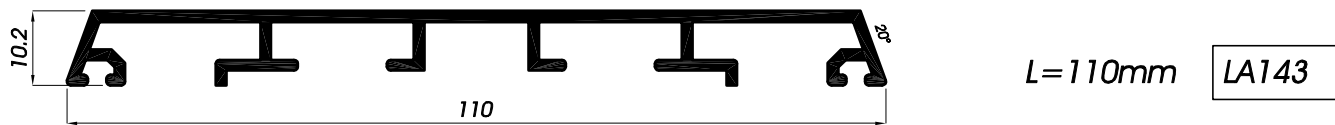
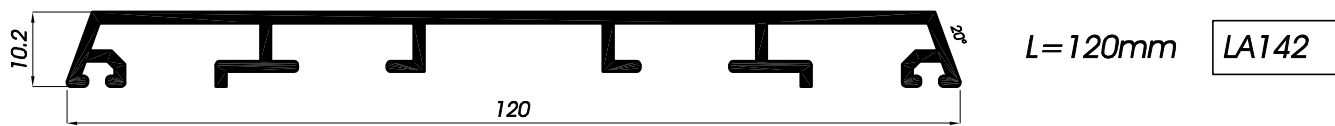
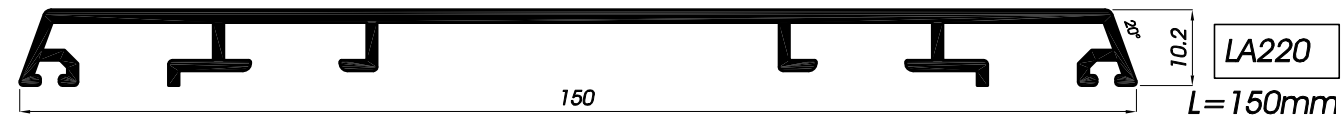

Profili in alluminio  
 Aluminiumprofile  
 Perfiles de aluminio  
 Profils en aluminium  
 Aluminium profiles

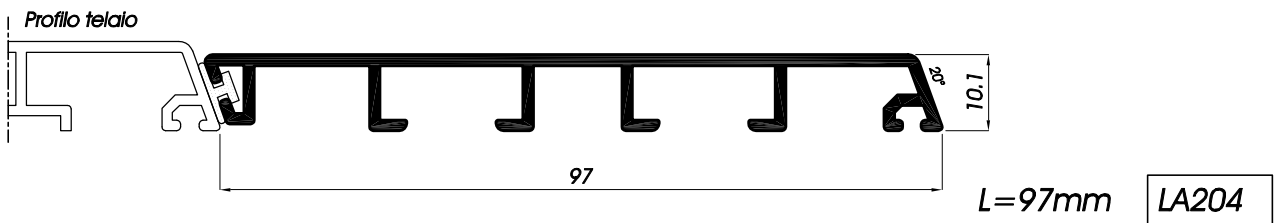
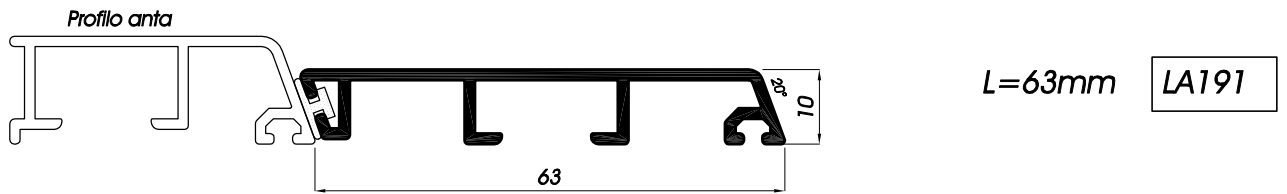
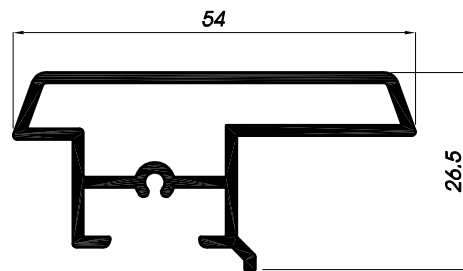
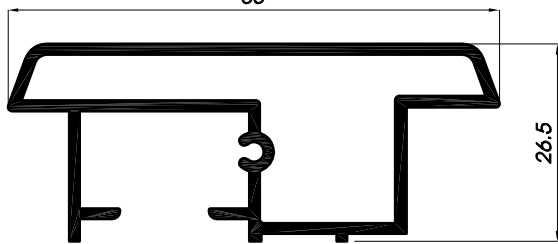
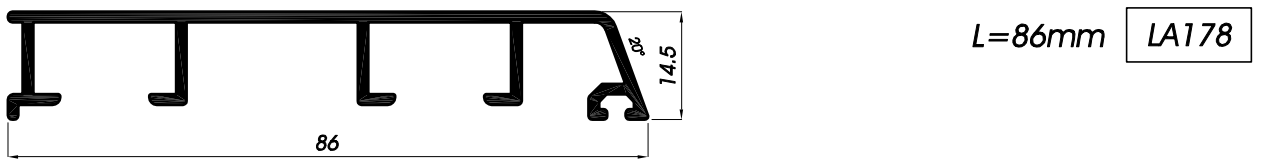
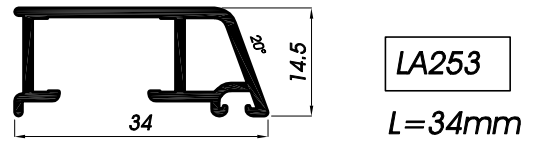
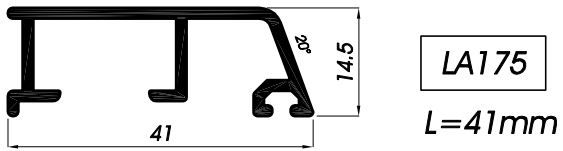

Profili in alluminio  
 Aluminiumprofile  
 Perfiles de aluminio  
 Profils en aluminium  
 Aluminium profiles

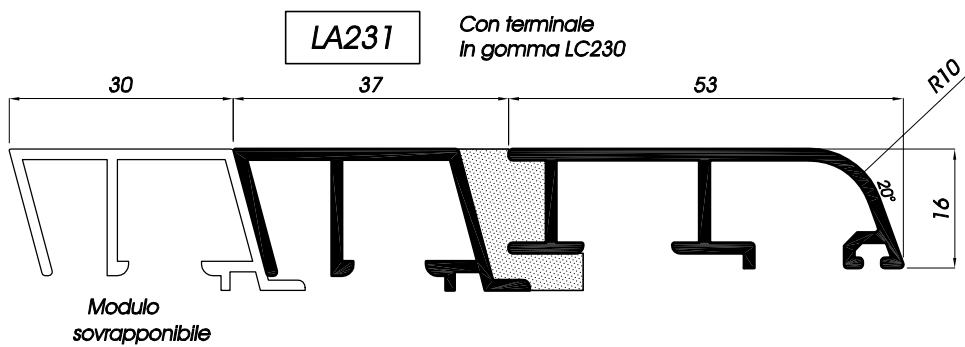

L=53mm

LA230

LA230c

con asole scarico acqua

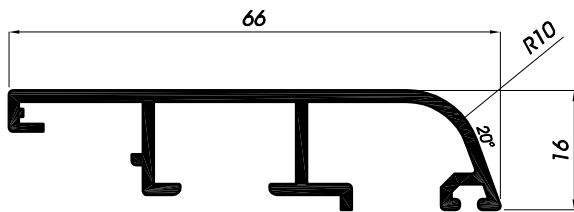

L=66mm

LA232

LA232c

con asole scarico acqua

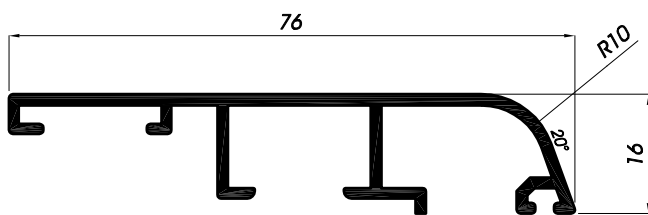

L=76mm

LA262

LA262c

con asole scarico acqua

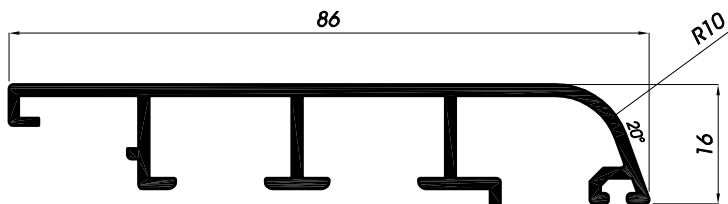

L=86mm

LA233

LA233c

con asole scarico acqua

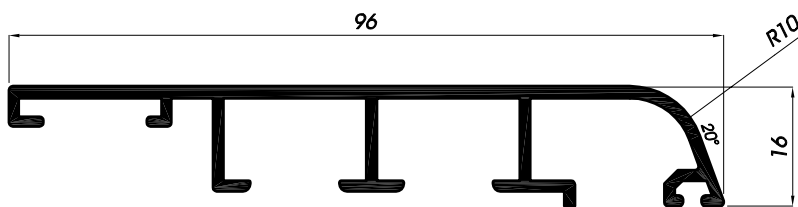

L=96mm

LA255

LA255c

con asole scarico acqua

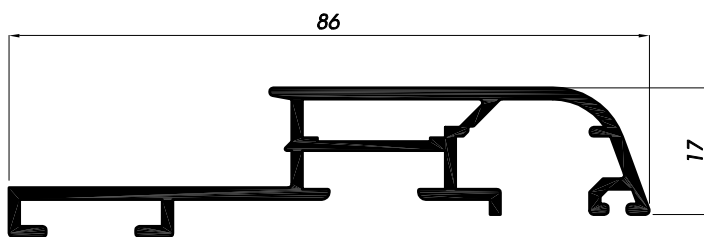

L=86mm

LA258

LA258c

con asole scarico acqua

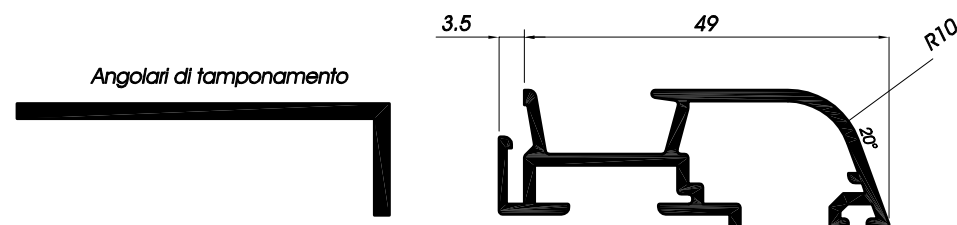

LA250

LA250c

con asole scarico acqua

Profili in alluminio  
 Aluminiumprofile  
 Perfiles de aluminio  
 Profils en aluminium  
 Aluminium profiles

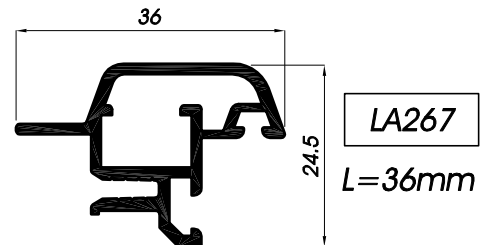
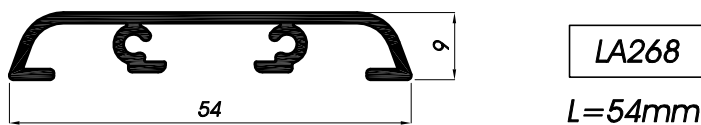
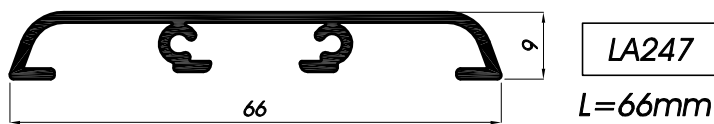
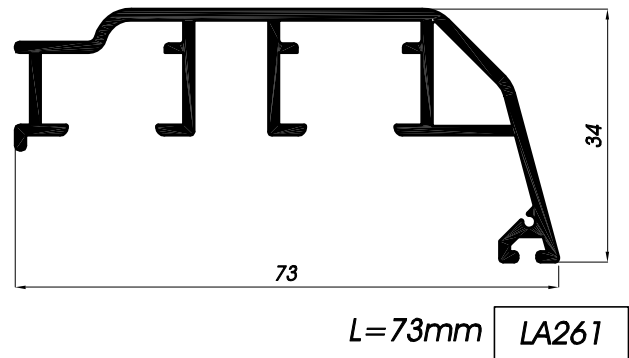
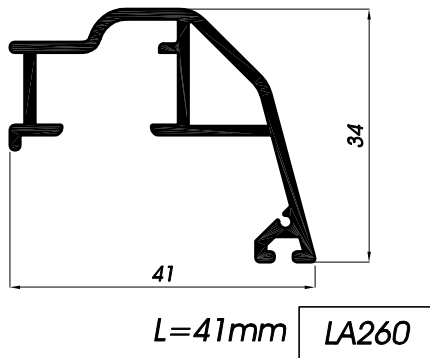
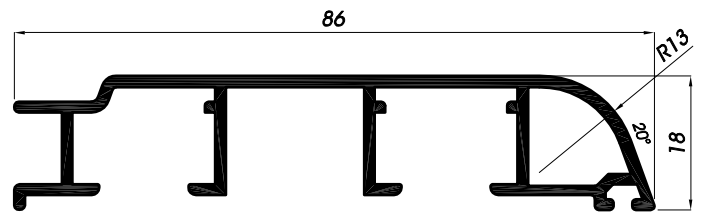
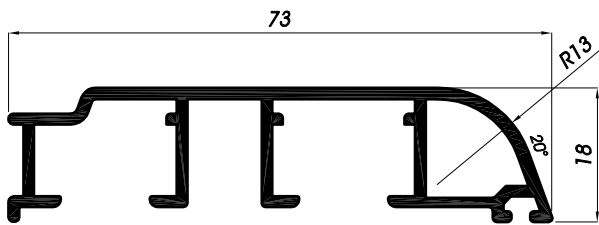
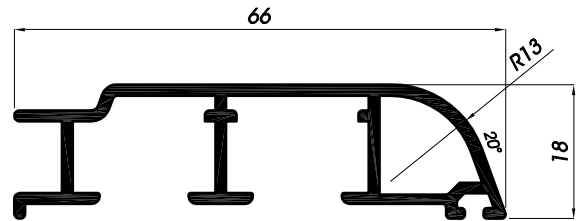
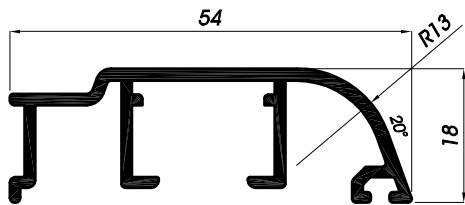
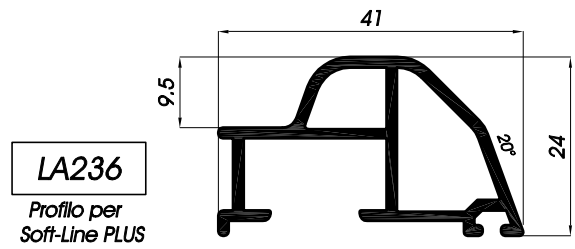
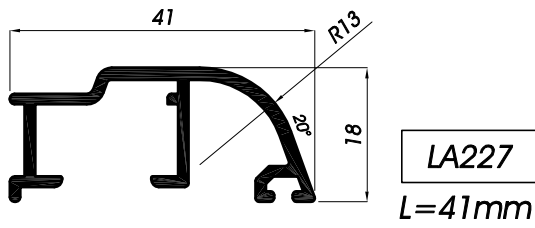
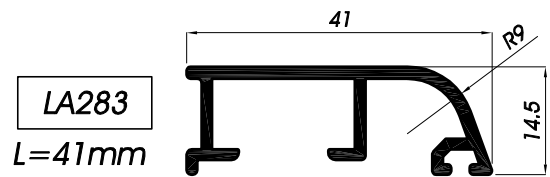
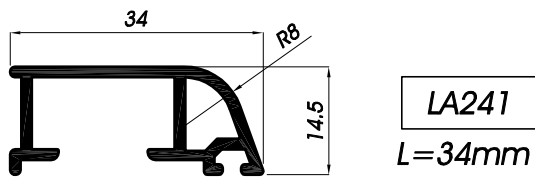

Profili in alluminio  
 Aluminiumprofile  
 Perfiles de aluminio  
 Profils en aluminium  
 Aluminium profiles

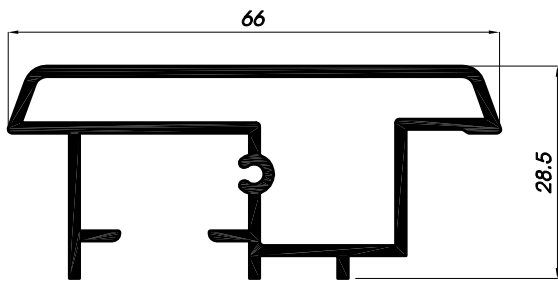

L=66mm LA263

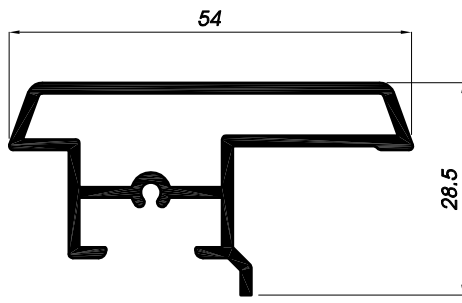

L=54mm LA264

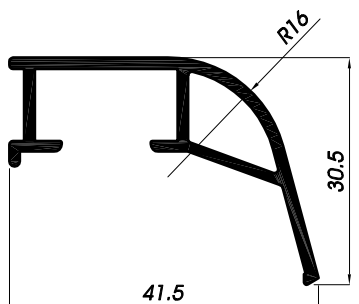

L=41.5mm LA254

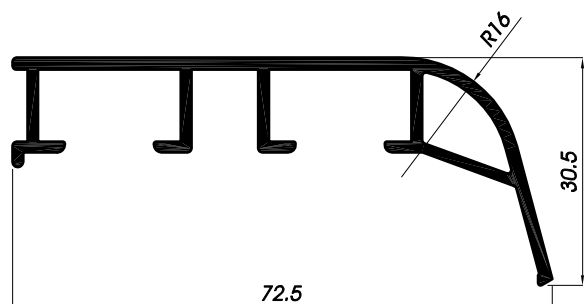

L=72.5mm LA256

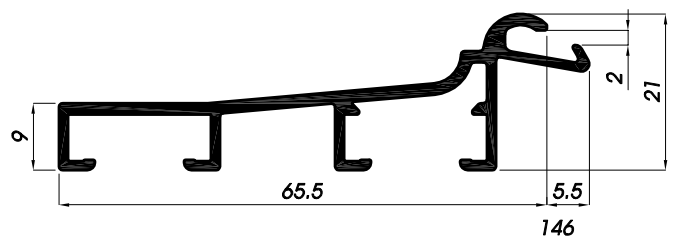

L=65.5mm LA269

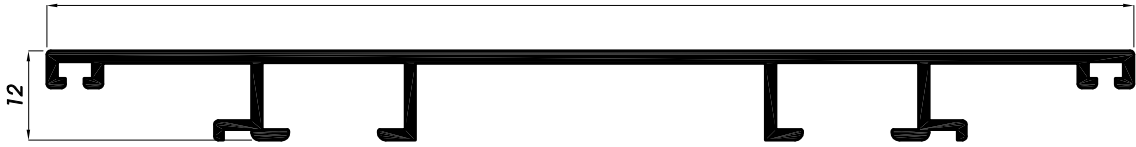

LA431  
L=146mm

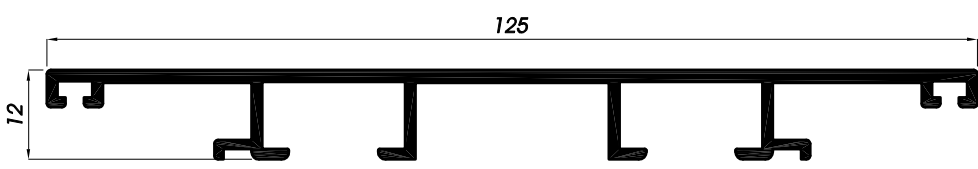

LA427  
L=125mm

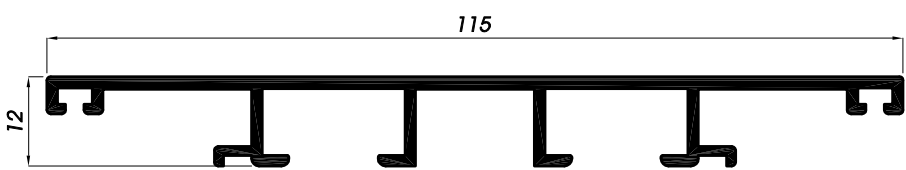

LA428  
L=115mm

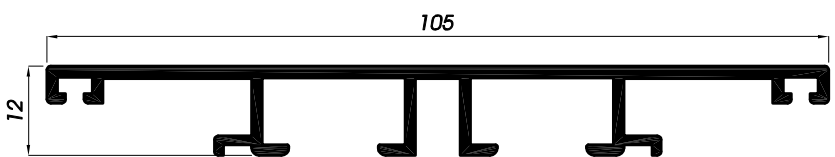

LA449  
L=105mm

Profili in alluminio  
 Aluminiumprofile  
 Perfiles de aluminio  
 Profils en aluminium  
 Aluminium profiles

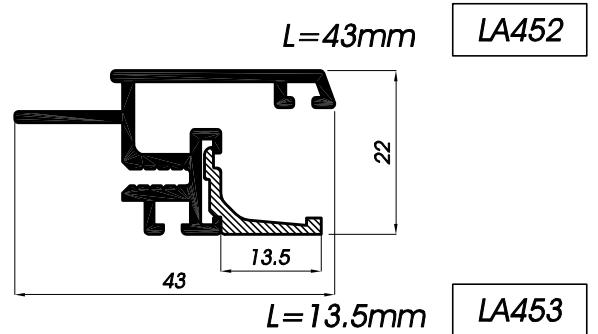
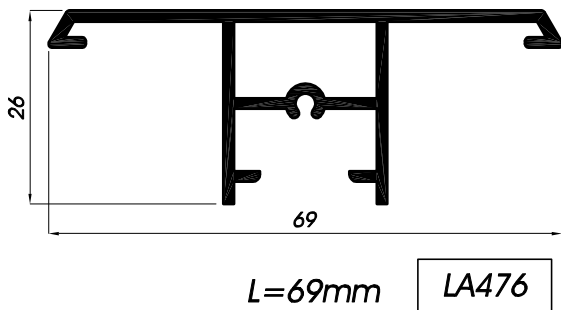
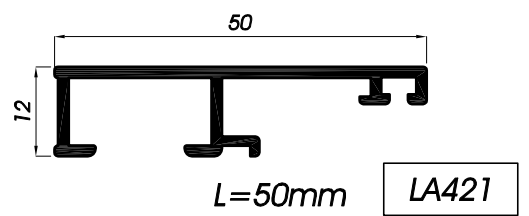
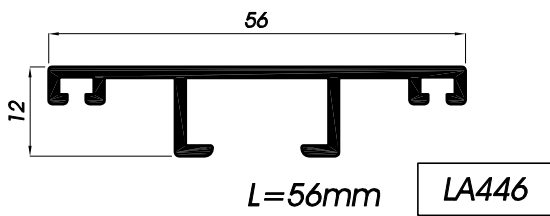
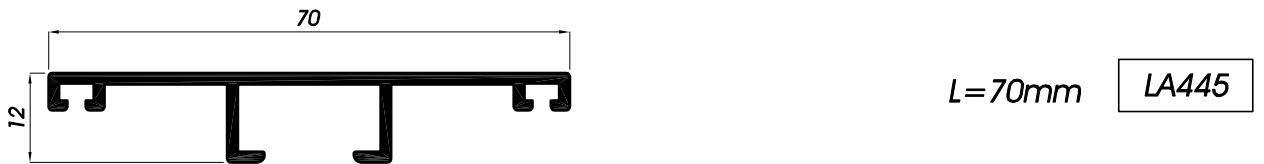
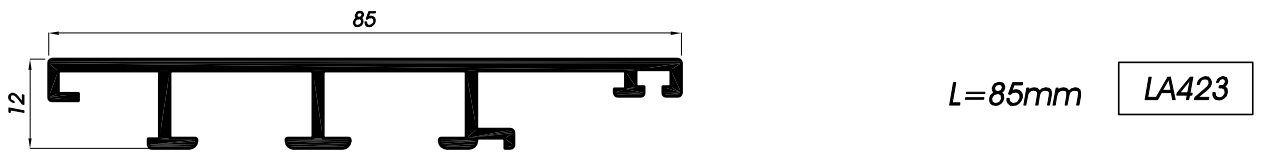
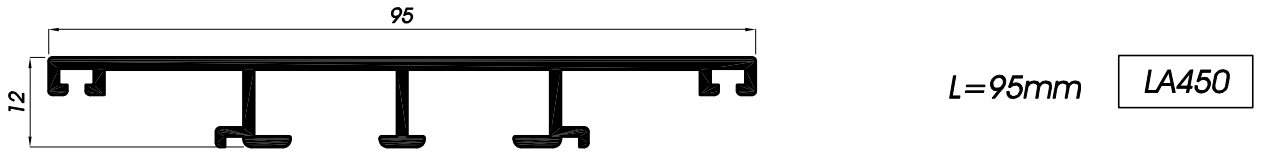
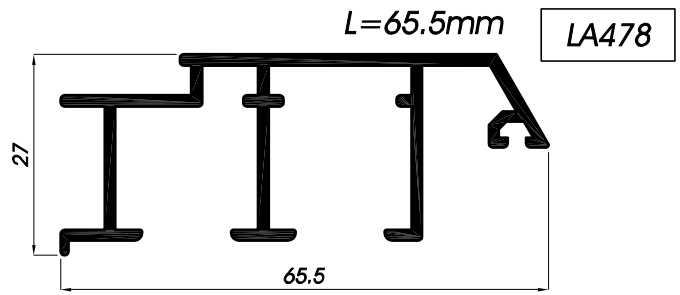
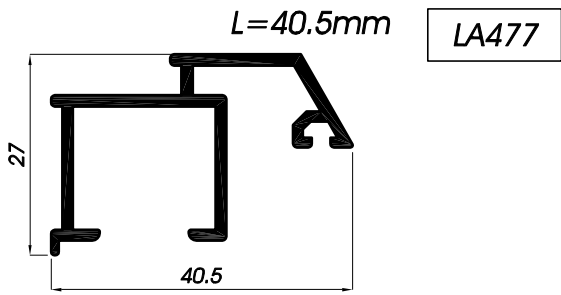

Profili in alluminio  
 Aluminiumprofile  
 Perfiles de aluminio  
 Profils en aluminium  
 Aluminium profiles

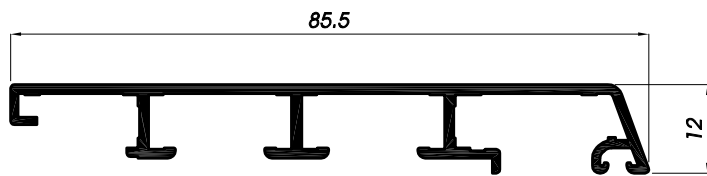

L=85.5mm

LA238

LA238c

con asole  
scarico acqua

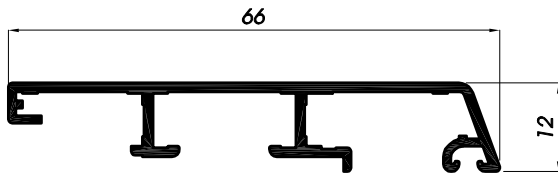

L=66mm

LA239

LA239c

con asole  
scarico acqua

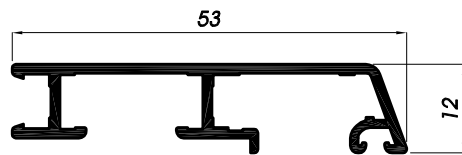

L=53mm

LA242

LA242c

con asole  
scarico acqua

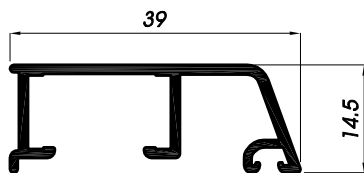

L=39mm

LA240

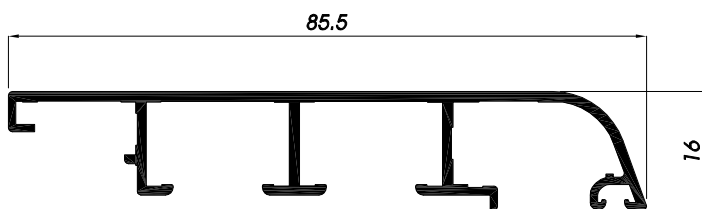

L=85.5mm

LA281

LA281c

con asole  
scarico acqua

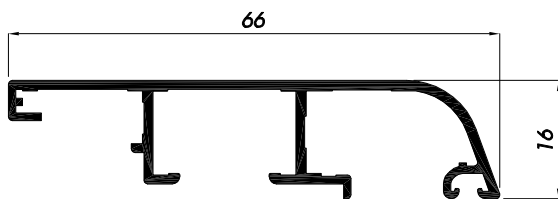

L=86mm

LA279

LA279c

con asole  
scarico acqua

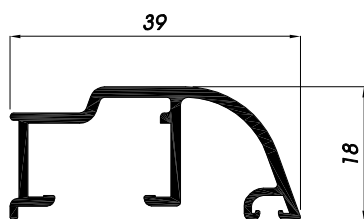

L=39mm

LA280

Profili in alluminio  
Aluminiumprofile  
Perfiles de aluminio  
Profils en aluminium  
Aluminium profiles

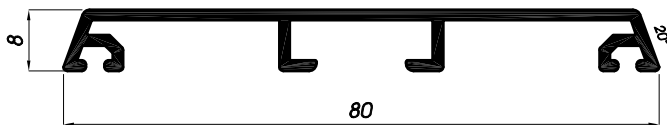

L=80mm LA201

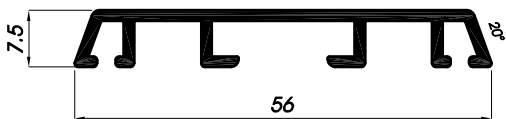

L=56mm LA202

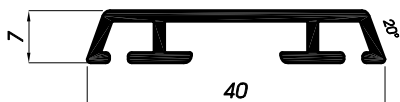

L=40mm LA203

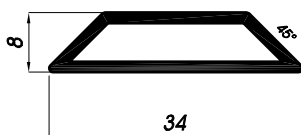

LA198  
L=34mm

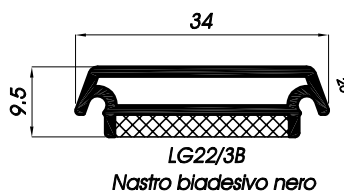

LA217  
L=34mm

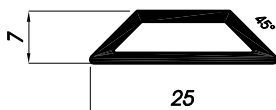

LA137  
L=25mm

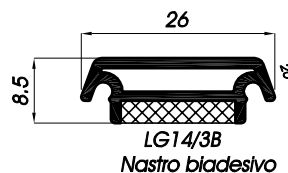

LA218  
L=26mm

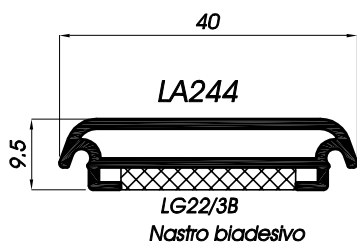

LA244  
L=40mm

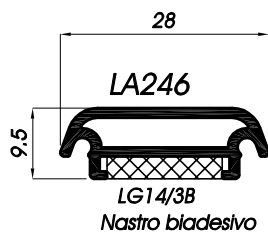

LA246  
L=28mm

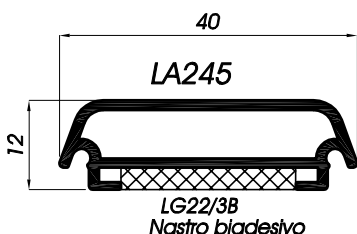

LA245  
L=40mm

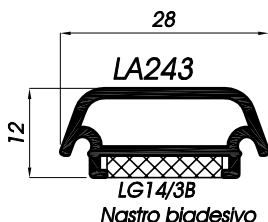

LA243  
L=28mm

Profili in alluminio  
Aluminiumprofile  
Perfiles de aluminio  
Profils en aluminium  
Aluminium profiles



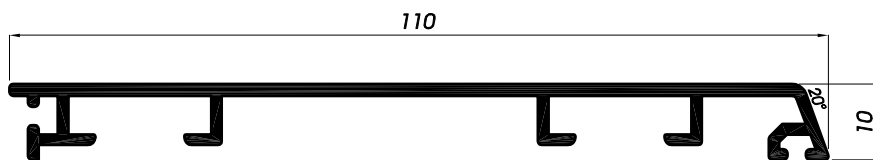

L=110mm LA211

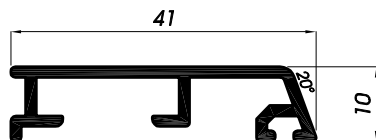

L=41mm LA212

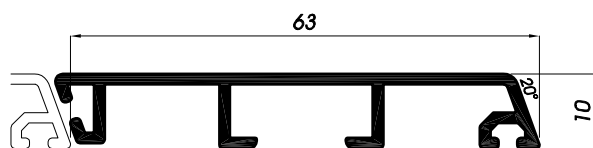

L=63mm LA191

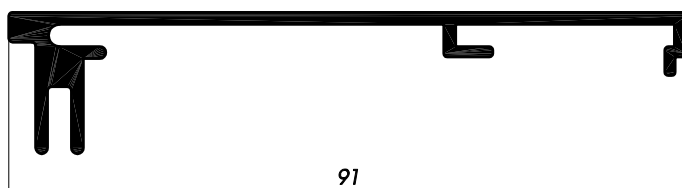

L=91mm LA115  
PER LEGNO  
SPESSORE 68mm

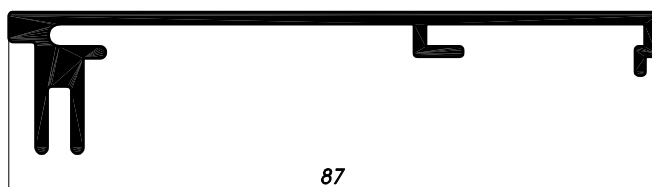

L=87mm LA161  
PER LEGNO  
SPESSORE 64mm

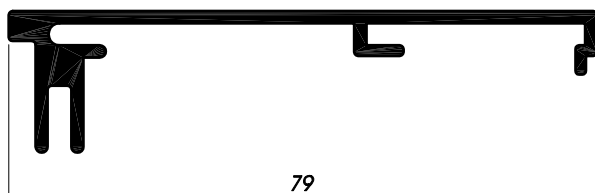

L=79mm LA114  
PER LEGNO  
SPESSORE 56mm

Profili per alzanti scorrevoli con sp. legno 68 - 64 - 56 mm.  
 Profile für Hebe-Schiebe-Tür mit Holzstärke 68 - 64 - 56 mm.  
 Perfiles para corredera elevadora con madera espesor 68 - 64 - 56 mm.  
 Profils pour fenêtres levantes coulissantes avec épaisseur 68 - 64 - 56 mm  
 Profiles for sliding window-door with wood's thickness of 68-64-56 mm

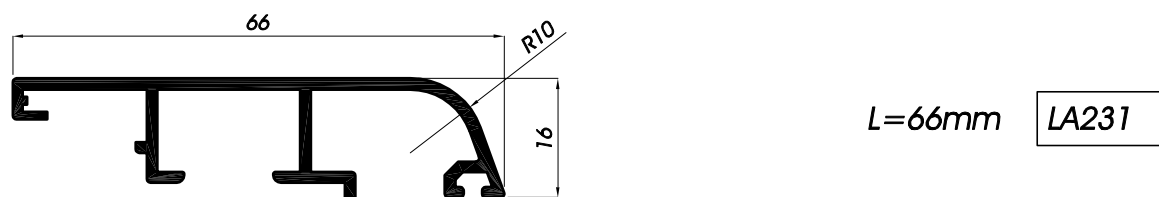
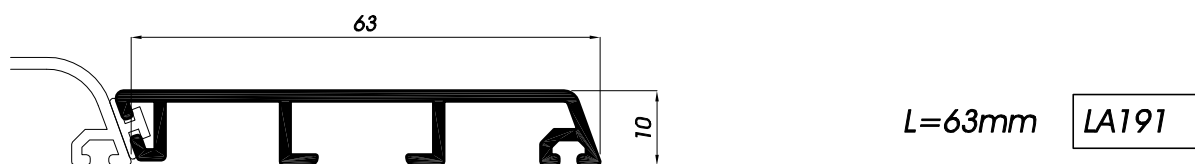
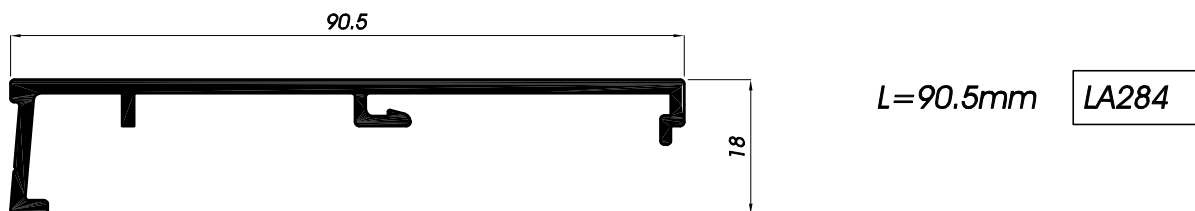
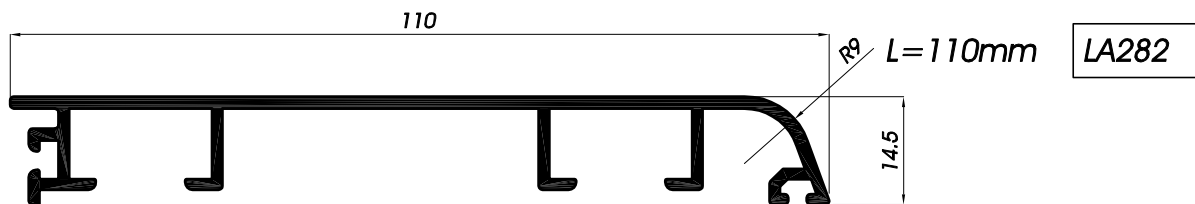

## PROFILI ESTRUSI

LA157-15

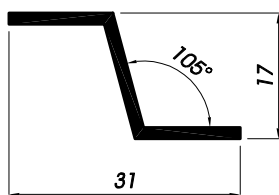

LA144

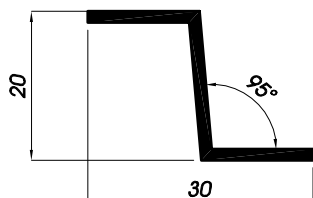

## LAMIERA PIEGATA

LA157-18

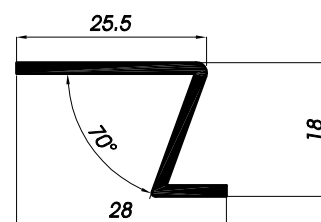

LA157-19

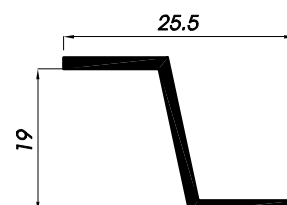

Profili per alzanti scorrevoli con sp. legno 68mm.  
 Profile für Hebe-Schiebe-Tür mit Holzstärke 68mm.  
 Perfiles para corredera elevadora con madera espesor 68mm.  
 Profils pour fenêtres levantes coulissantes avec épaisseur 68mm  
 Profiles for sliding window-door with wood's thickness of 68mm

**BINARI SUPERIORI:**

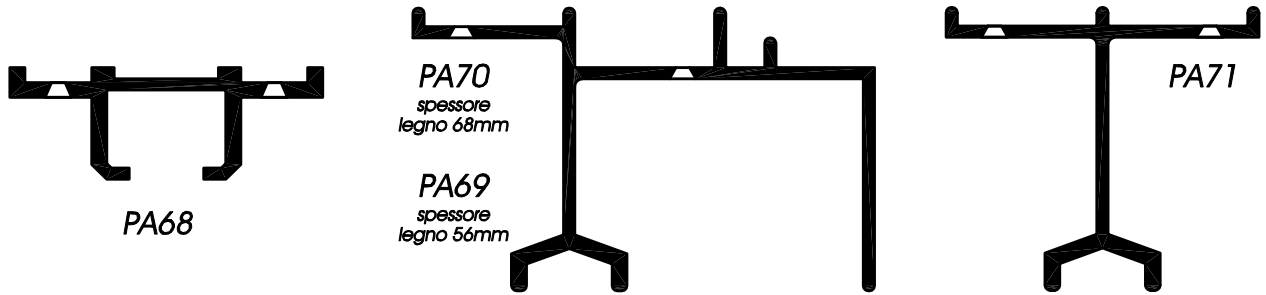

**BINARI INFERIORI:**

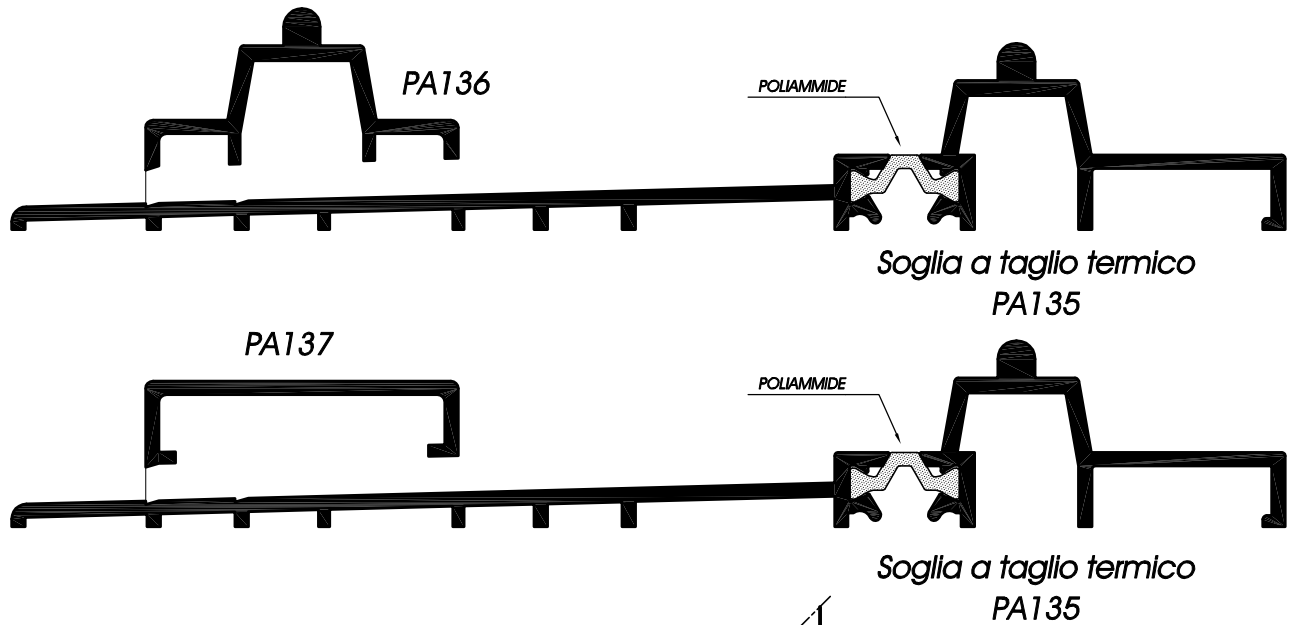

**ACCESSORI:**

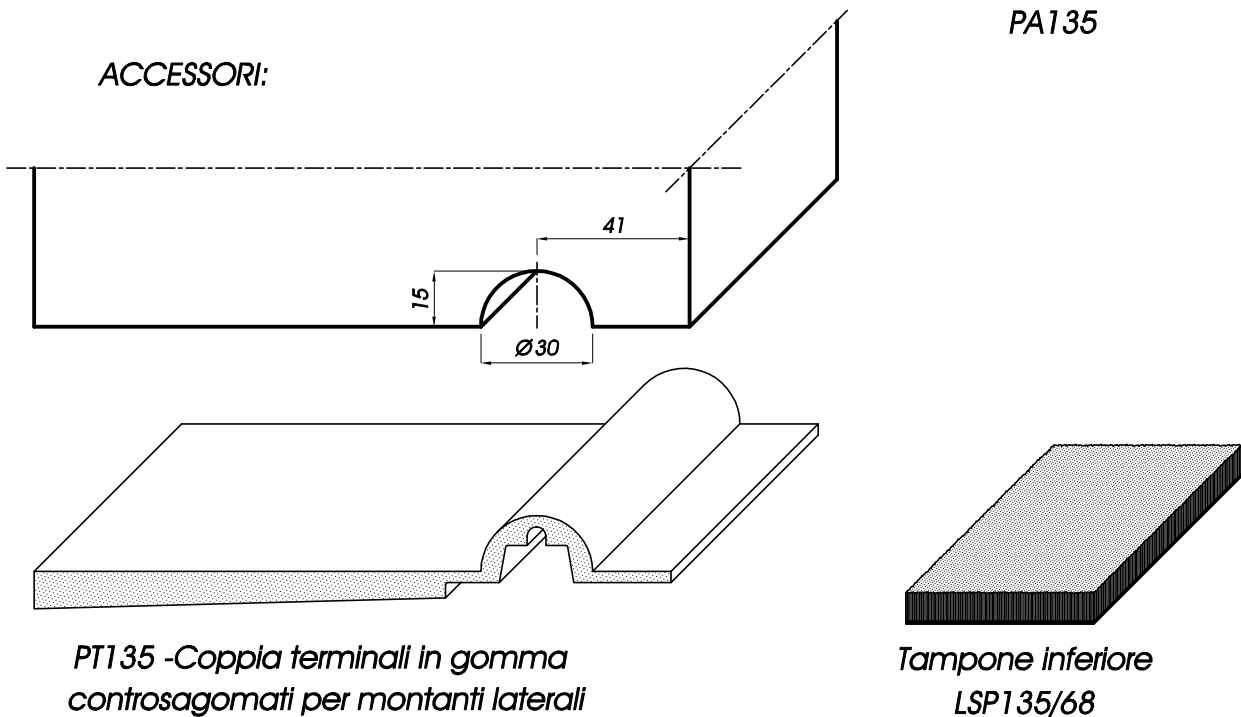

*Profili per alzanti scorrevoli - binari superiori, inferiori e accessori  
Profile für Hebe-Schiebe-Tür - Schienen oben, unten und Zubehör  
Perfiles para corredera elevadora y accesorios  
Profils pour fenêtres levantes coulissantes - rails supérieurs, inférieurs et accessoires  
Profiles for the sliding window-doors - upper and lower running tracks and spare parts*

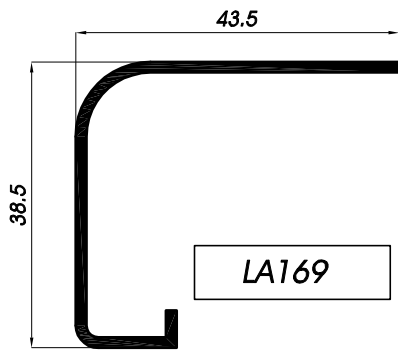

LA169

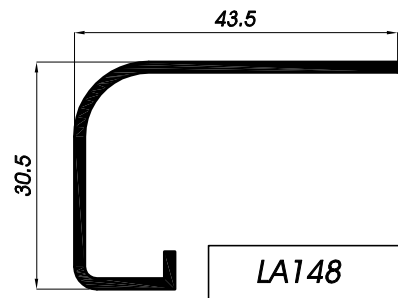

LA148

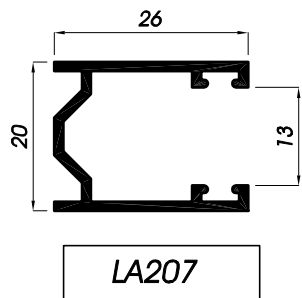

LA207

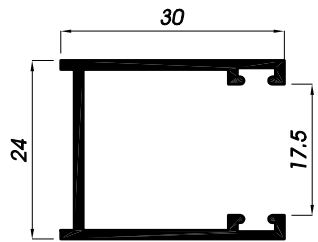

LA11

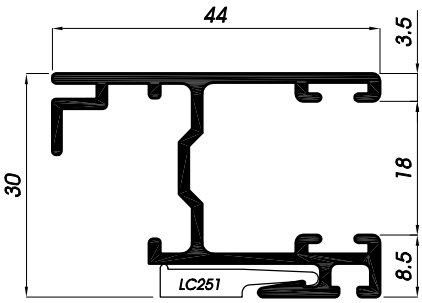

LA251

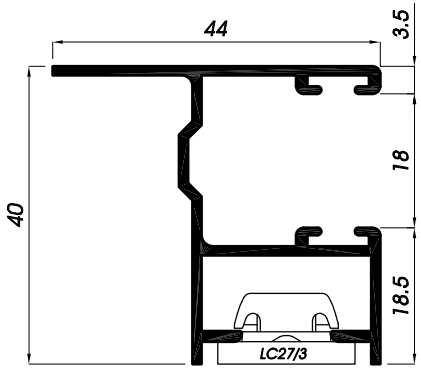

LA174

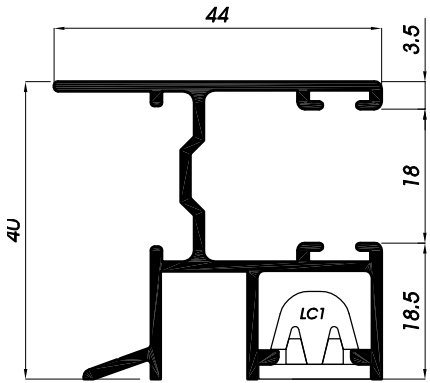

PA22

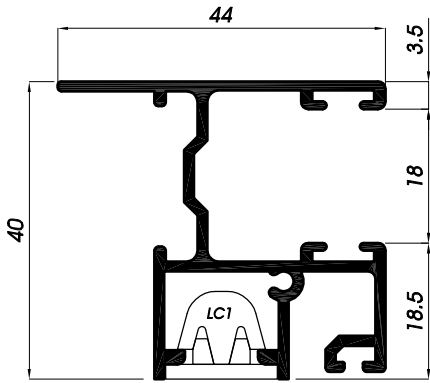

LA226

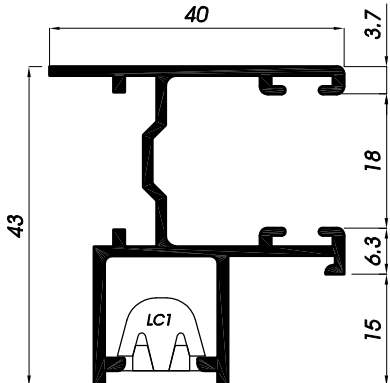

LA182

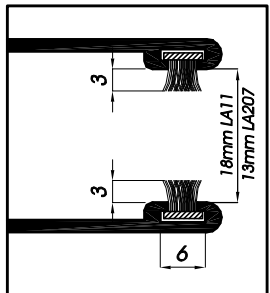

LSP 6

Guarnizione a spazzolino  
 MATERIALE: Nylon  
 COLORE: Nero  
 PROFILO: LA11-LA207

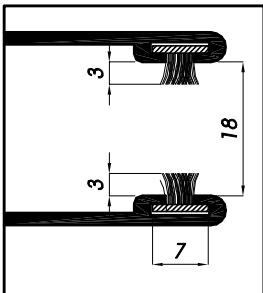

LSP 8

Guarnizione a spazzolino  
 MATERIALE: Nylon  
 COLORE: Nero  
 PROFILO: LA182-LA226-LA251

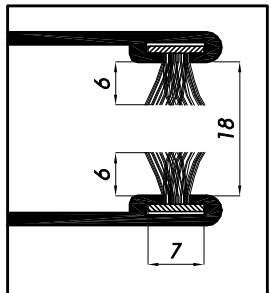

LSP 9

Guarnizione a spazzolino  
 MATERIALE: Nylon  
 COLORE: Nero  
 PROFILO: LA182-LA226-LA251

**Guide per avvolgibili, terminali e guarnizioni a spazzolino**  
**Rolladenführungen, Endstücke und Bürstendichtungen**  
**Perfiles guía de persiana y accesorios**  
**Coulisses volets roulants, embouts et joints à brosse**  
**Guides for roller blinds, terminals and brush-gaskets**



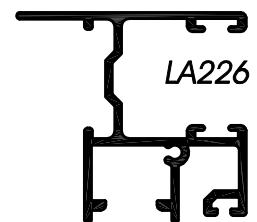
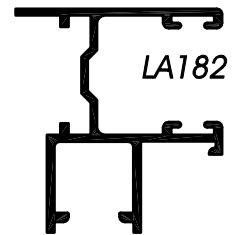
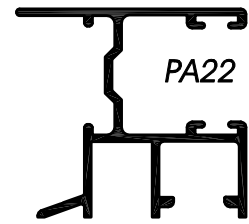
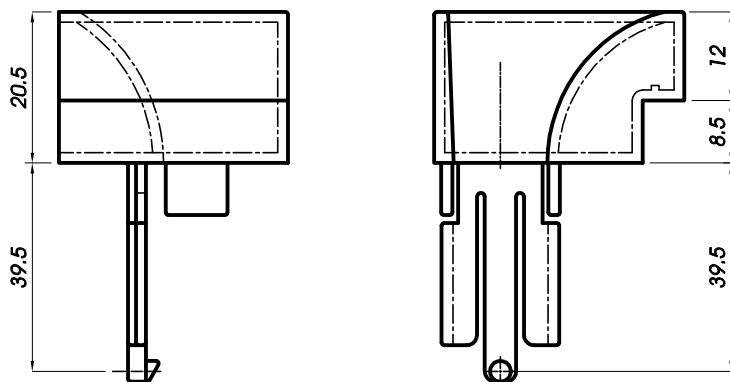
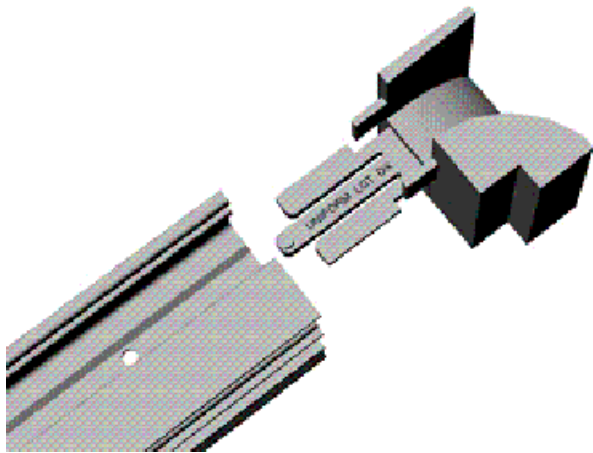

# Nuovo terminale LGT per guide avvolgibili

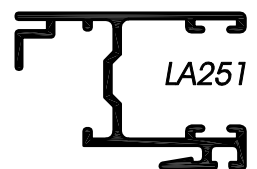
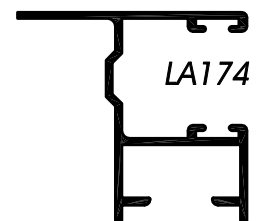
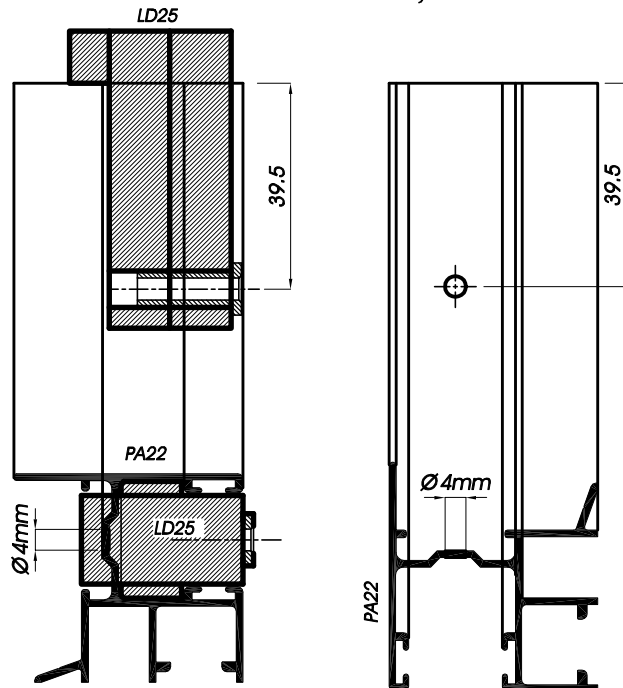

Eseguire foro  $\varnothing 4\text{mm}$  a 39,5mm con dima LD25



**Nuovo terminale LGT e modalità di impiego della nuova dima LD25**  
**Neue Endstücke LGT und Anwendung der neuen Lehre LD25**  
**Nuevo terminal LGT y modo de empleo para la nueva plantilla LD25**  
**Nouvel embout LGT et exemple d'utilisation du gabarit LD25**  
**New terminal LGT and using modality for the new template LD25**

PROFILI ANGOLARI		PROFILI PIANI		PROFILI SP. 4mm	
					
A15x15	15x15x2	P20x2	20x2	P30x4	30x4
A15x25	15x25x2	P30x2	30x2	P40x4	40x4
A15x30	15x30x2	P40x2	40x2	P50x4	50x4
A15x50	15x50x2	P50x2	50x2		
A15x80	15x80x2	P60x2	60x2		
A20x20	20x20x2	P80x2	80x2		
A20x30	20x30x2	P100x2	100x2		
A30x30	30x30x2	<b>PROFILI TUBOLARI</b>			
A40x20	40x20x2				
A40x40	40x40x2	T30x15	30x15x2		
A50x20	50x20x2	T40x20	40x20x2		
A60x20	60x20x2	T50x20	50x20x2		
A80x15	80x15x2				
A80x20	80x20x2				

## LAMIERE PIANE

LAM 1	Lamiera alluminio	- 1250x2500x1.5	(Bianco - A1K-B15K - RAL)
LAM 2	Lamiera bronzo	- 1000x2000x1.5	(Bronzo)
LAM 3	Lamiera alluminio	- 1500x3500x1.5	(Decorato finto legno)

*Profili vari e lamiera*  
*Verschiedene Profile und Aluminiumbleche*  
*Perfiles varios y chapas de aluminio*  
*Autres profils et tôles aluminium*  
*Various profiles and sheets*

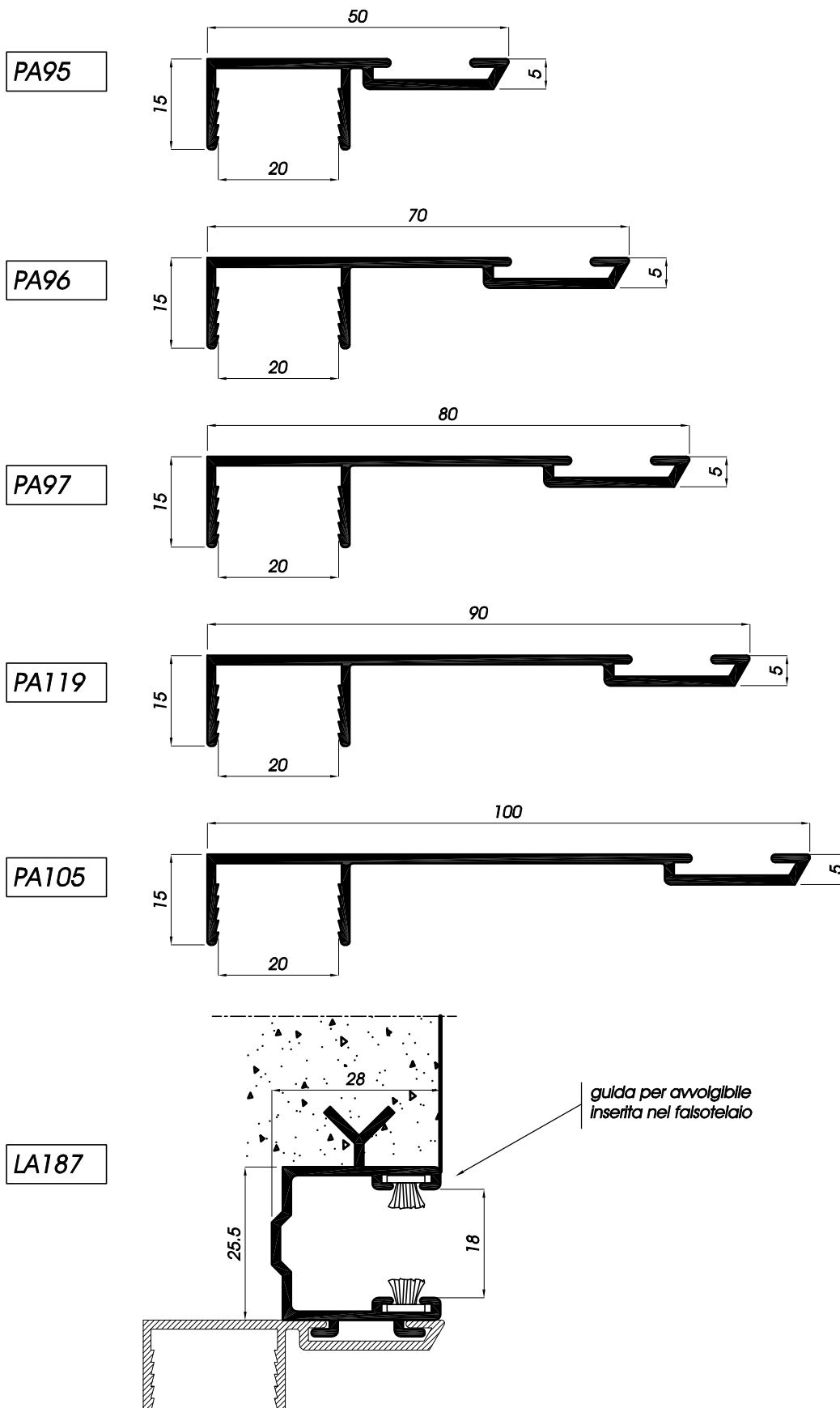

**Profili per falsotelaio e guida avvolgibile LA187**  
**Zargenprofile und Rolladenführungsprofil LA187**  
**Perfiles para premarco y guía de persiana LA187**  
**Profils pour pré-cadres et coulisse volet roulant LA187**  
**Profiles for case and turning guide LA187**

PA151

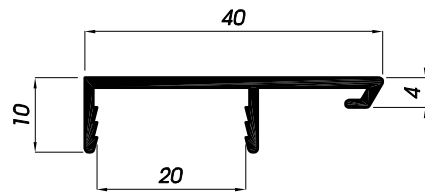

PA152

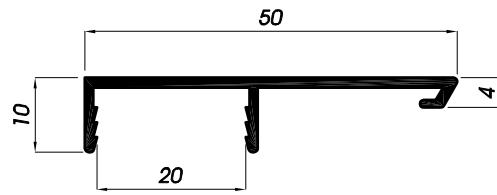

PA164

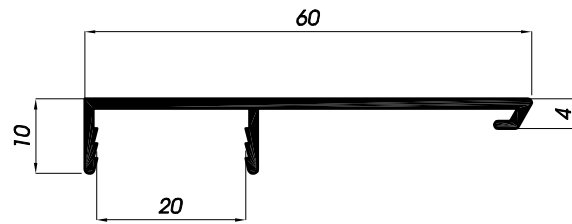

PA153

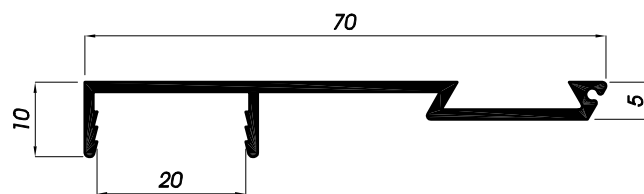

PA154

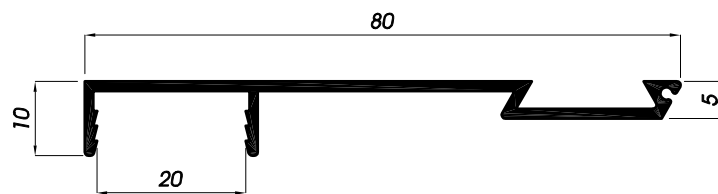

PA155

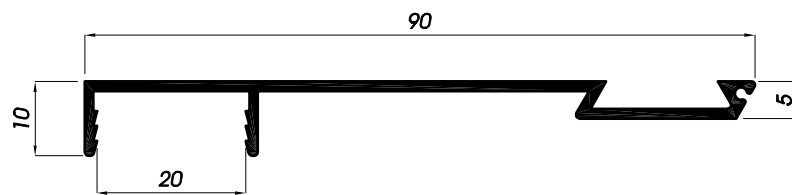

PA156

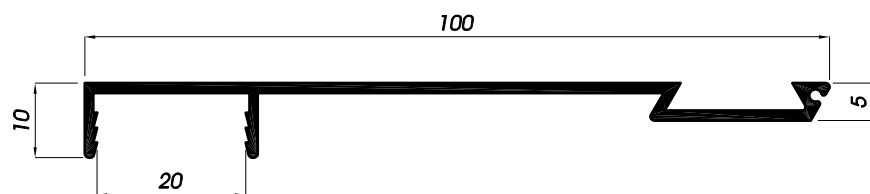

**Profili per falsotelaio**  
**Blindstockprofile**  
**Perfiles para premarco**  
**Profils pour pré-cadres**  
**Profiles for case**



# LAVORAZIONE (LAV 01) SU PROFILI PER FALSOTEGLIAIO

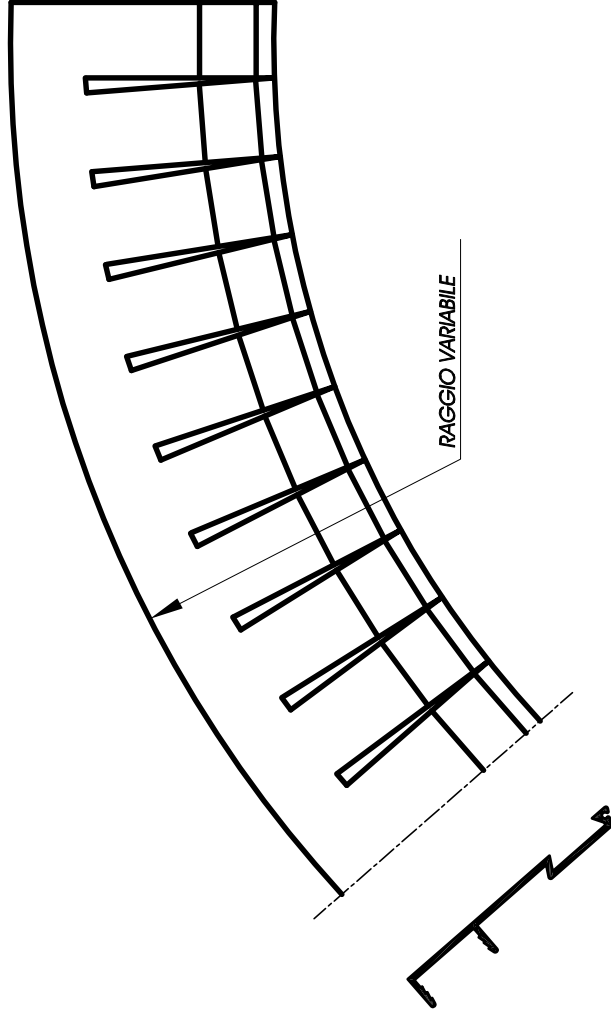
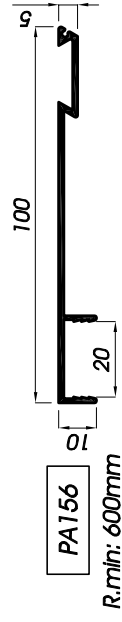
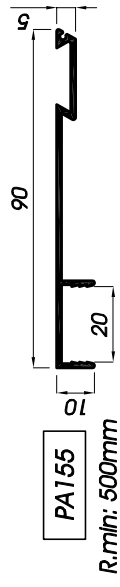
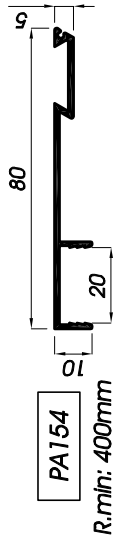
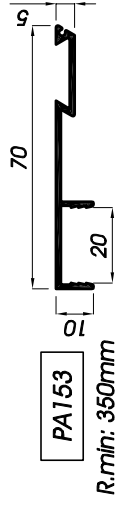
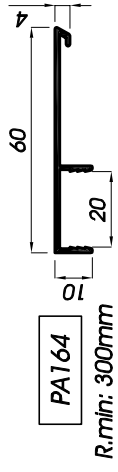
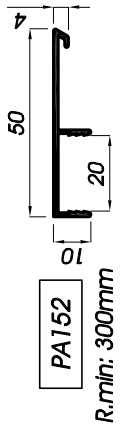
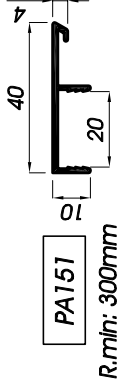
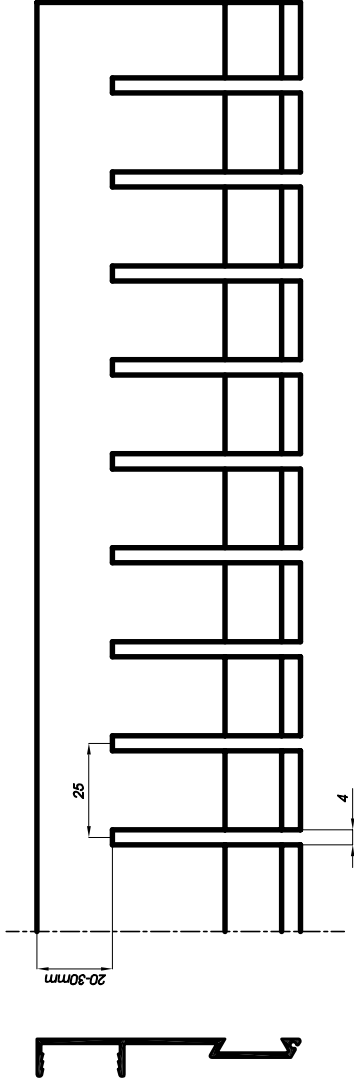

Lavorazione di fresatura su falsoteGLIAIO per adattamento su finestre ad arco  
 Vorbearbeitung der Blindstockprofile zur Anpassung an Bogenfenster  
 Fresado en los premarcos para el ajuste en las ventanas curvadas  
 Usinage des pré-cadres pour fenêtres cintrées  
 Tooling over the case for mounting on the roundel window

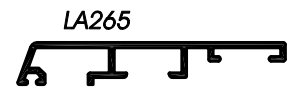
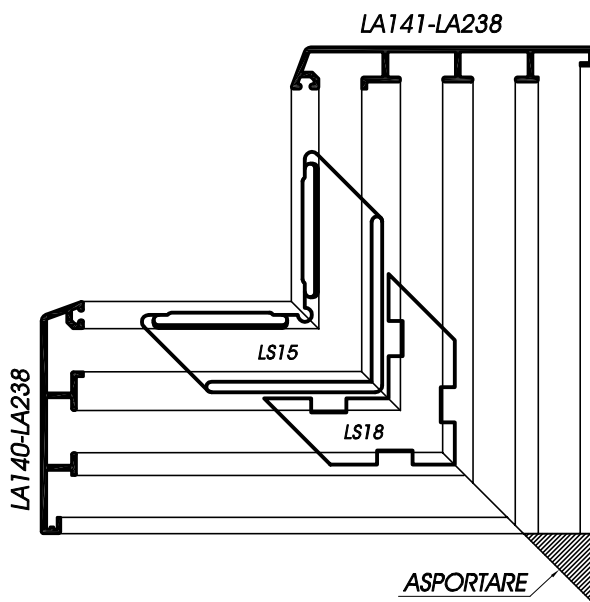
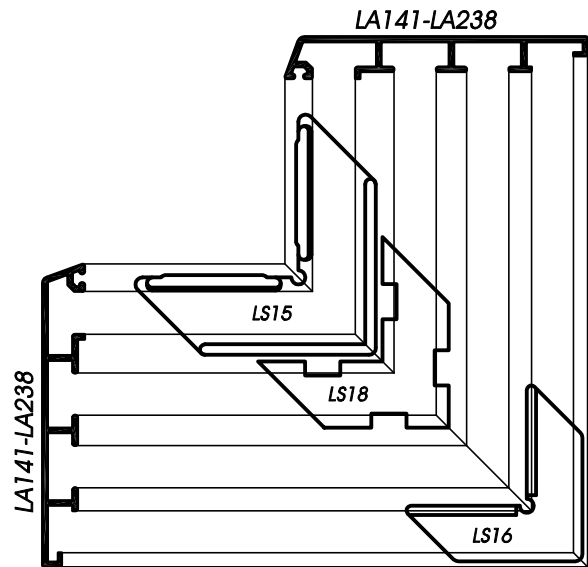
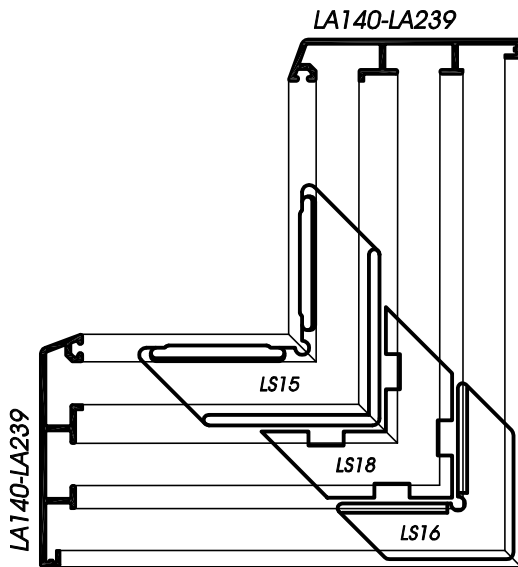

LA222

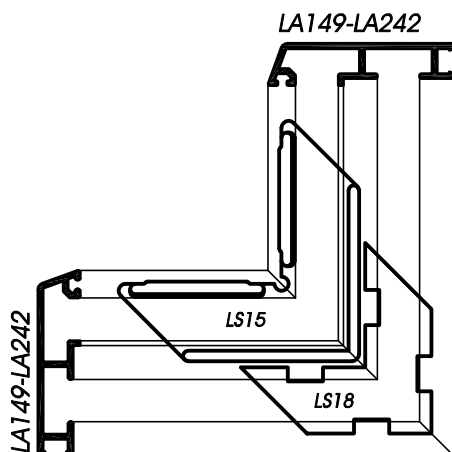
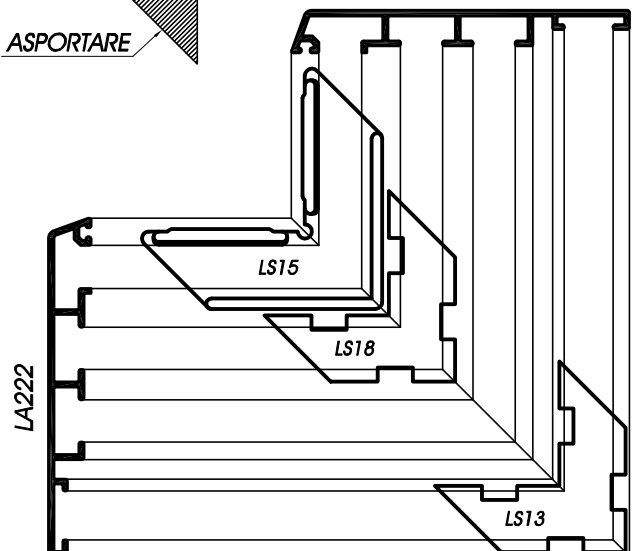

Squadrette per profili telaio  
 Eckwinkel für Rahmenprofile  
 Escuadras para perfiles del marco  
 Equerres pour profils dormant  
 Corner spigot for frame's profiles

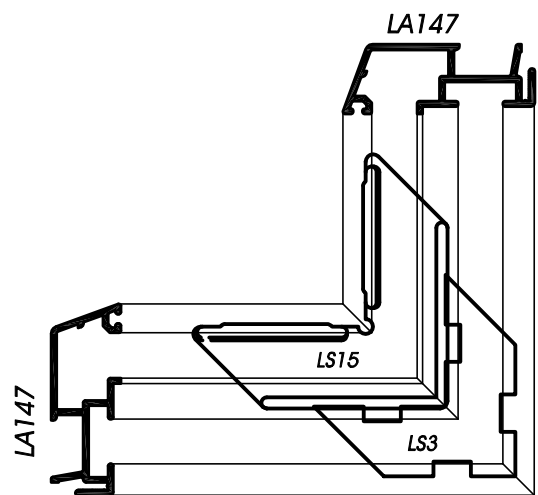
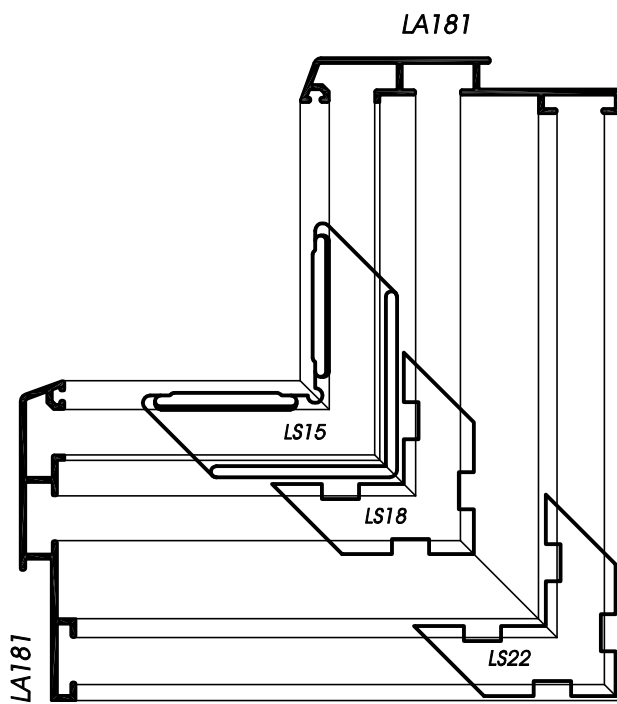
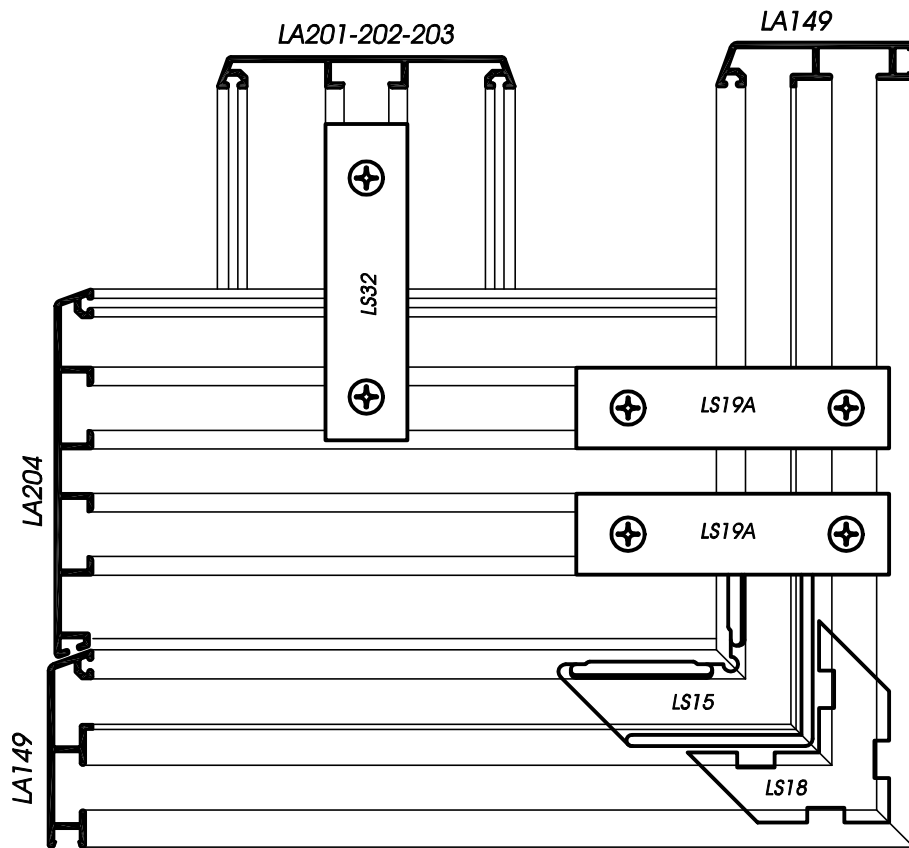

Squadrette per profili telaio  
 Eckwinkel für Rahmenprofile  
 Escuadras para perfiles del marco  
 Equerres pour profils dormant  
 Corner spigot for frame's profiles

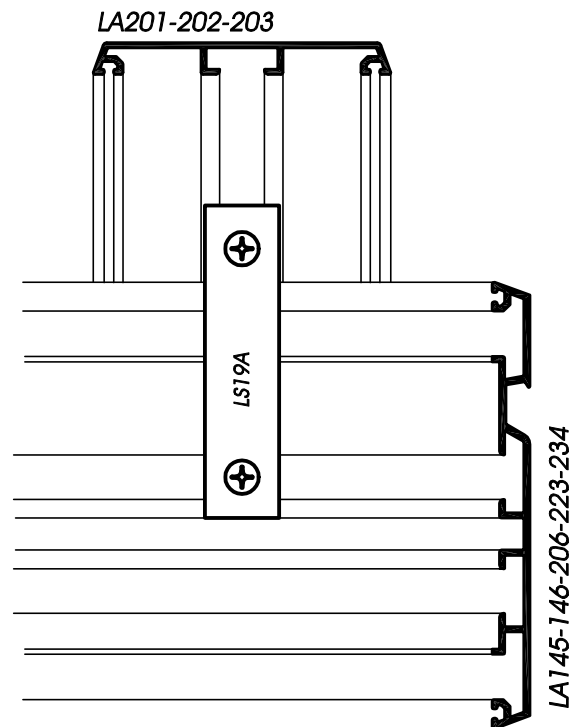
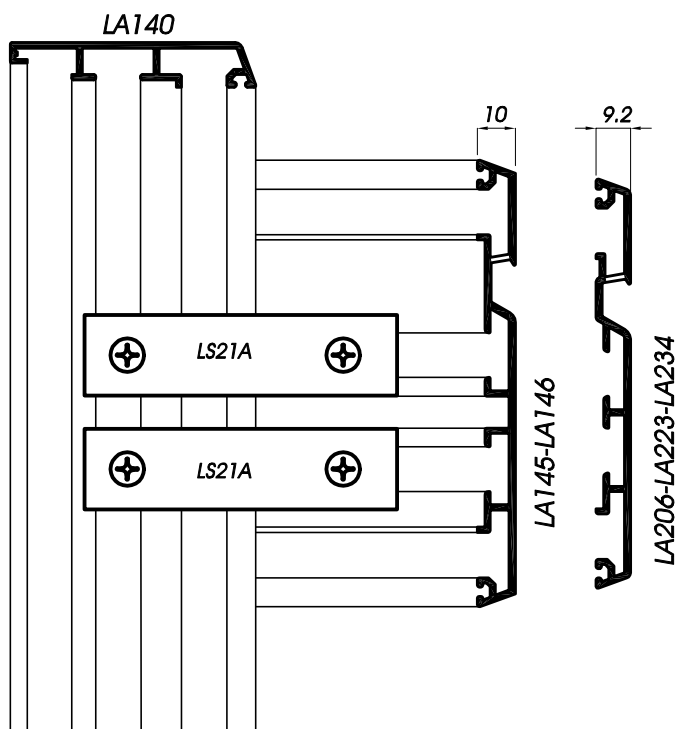
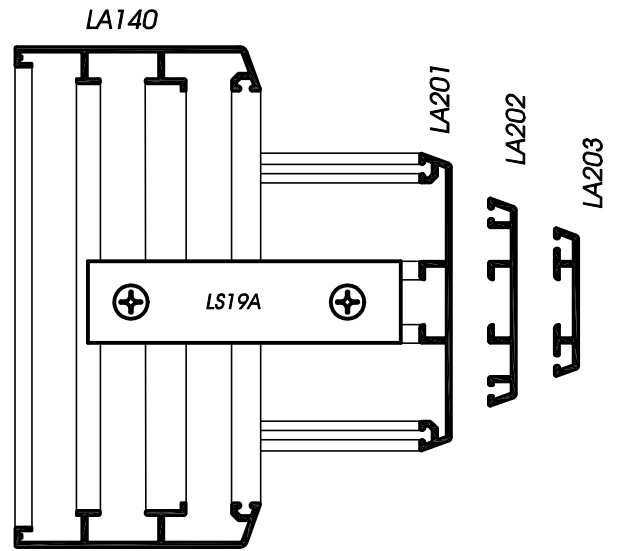
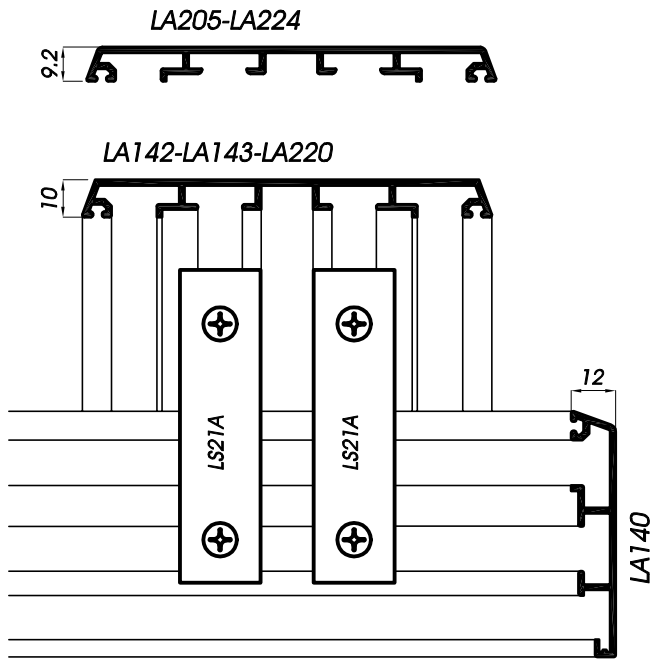

Squadrette per traversi intermedi telaio  
 Sprossenverbinder T - Verbindung  
 Escuadras para travesaños intermedios  
 Equerres pour traverses intermédiaires dormant  
 Corner spigot for frame's middle ledgers

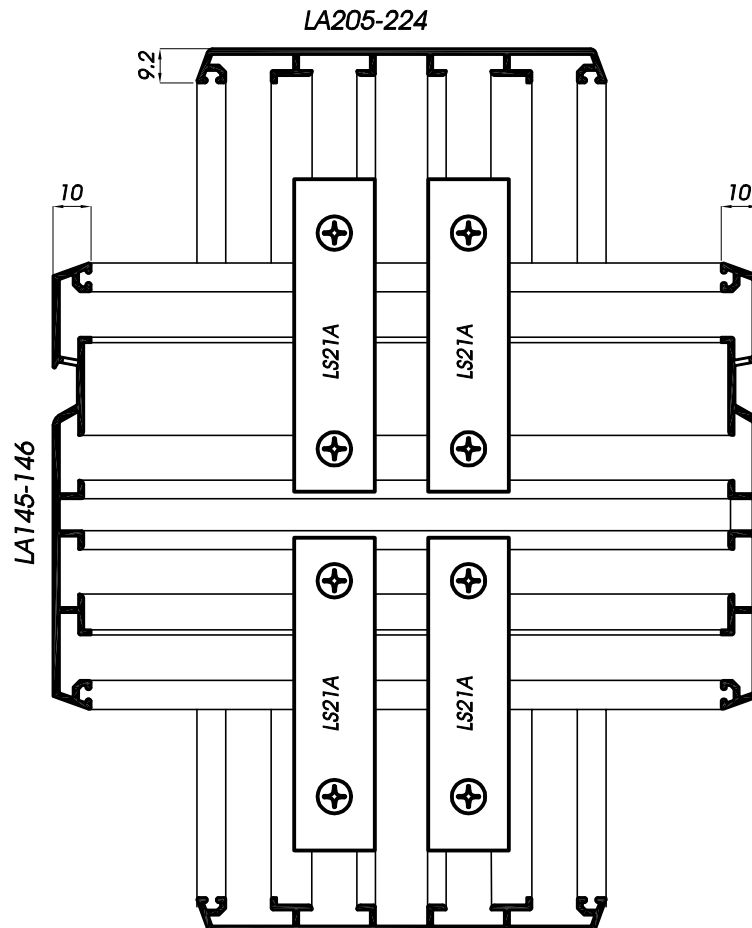
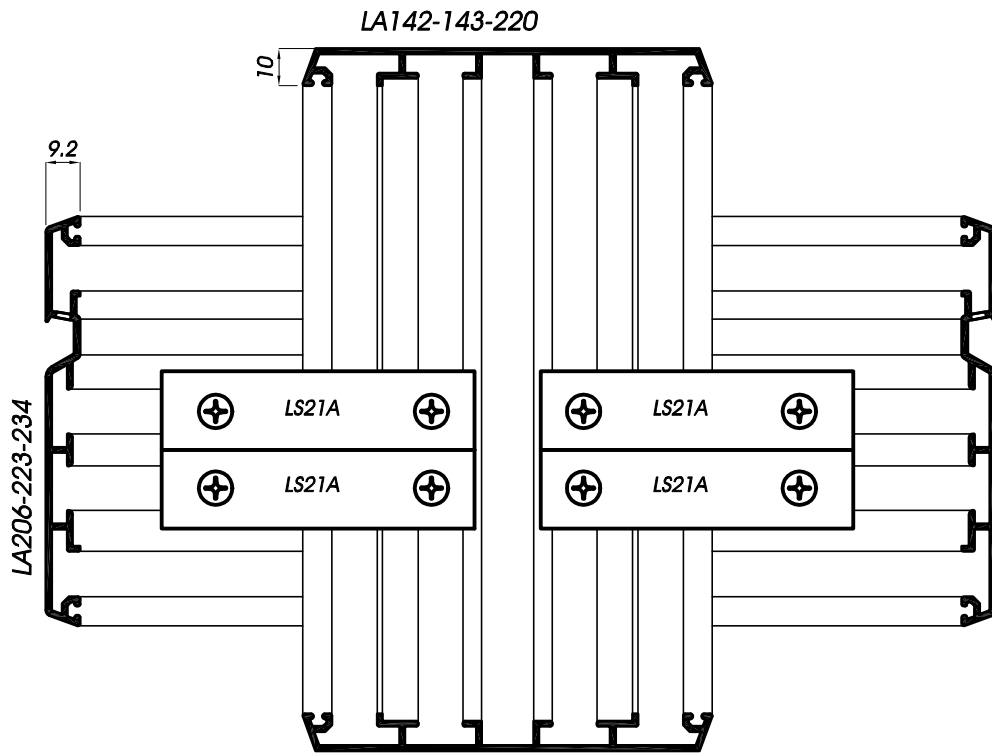

*Squadrette per accoppiamenti a croce*  
*Kreuzverbinder*  
*Escuadras para acoplamiento cruzados*  
*Equerres pour assemblage en croix*  
*Corner spigot for cross assembly*



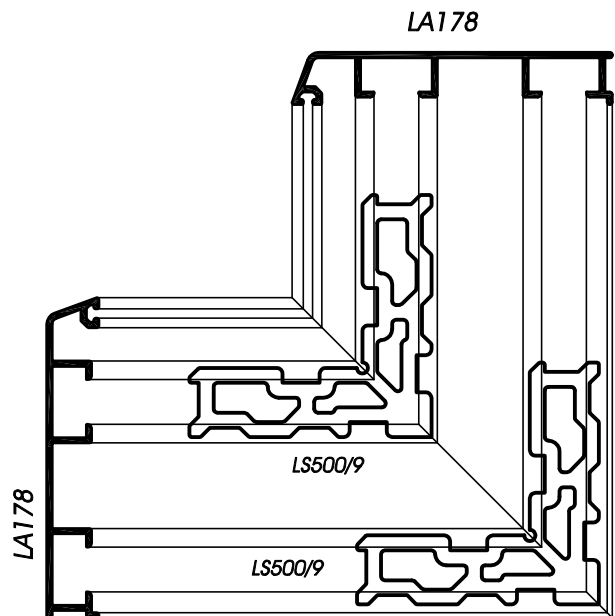
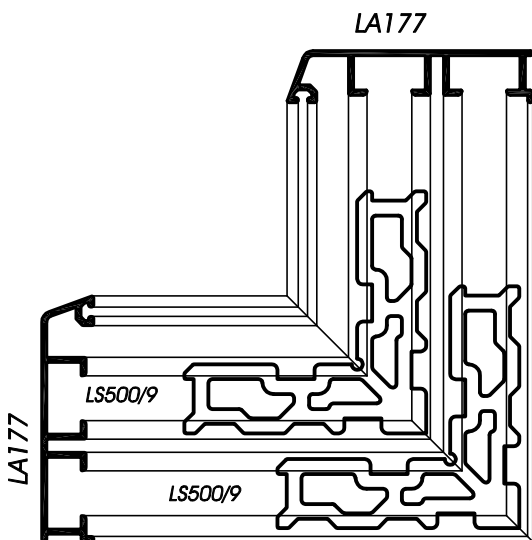
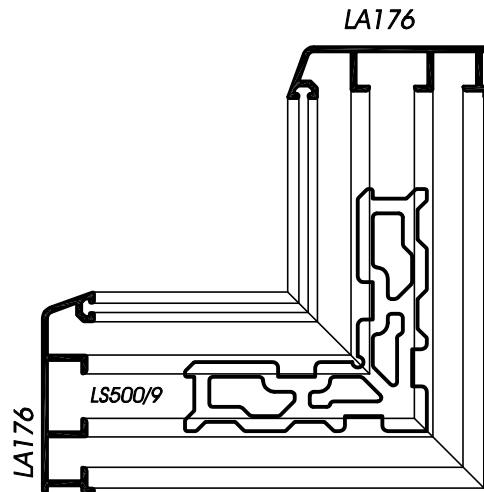
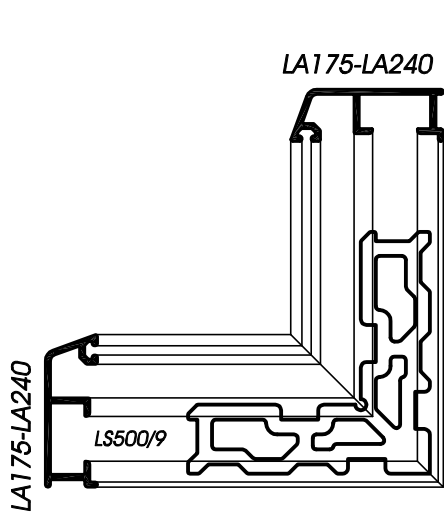
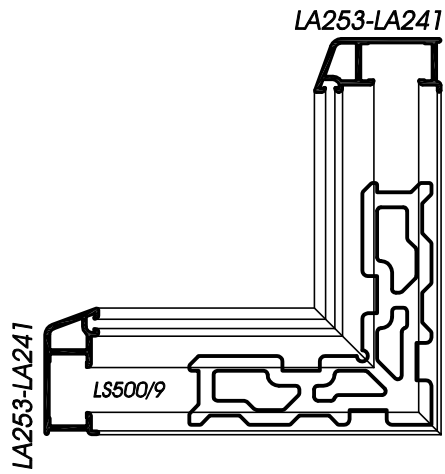

Squadrette per profili anta  
 Eckwinkel für Flügelprofile  
 Escuadras para perfiles de la hoja  
 Equerres pour profils vantaux  
 Corner spigot for wing's profiles

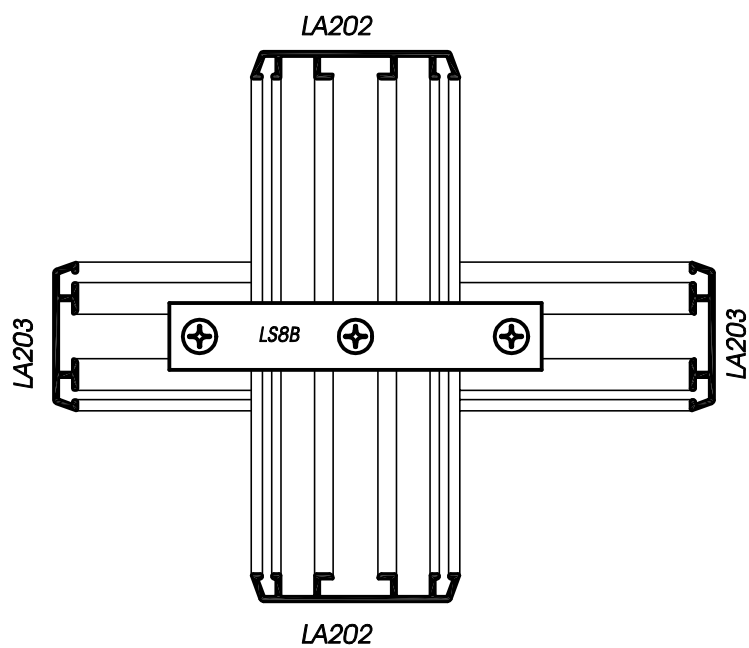
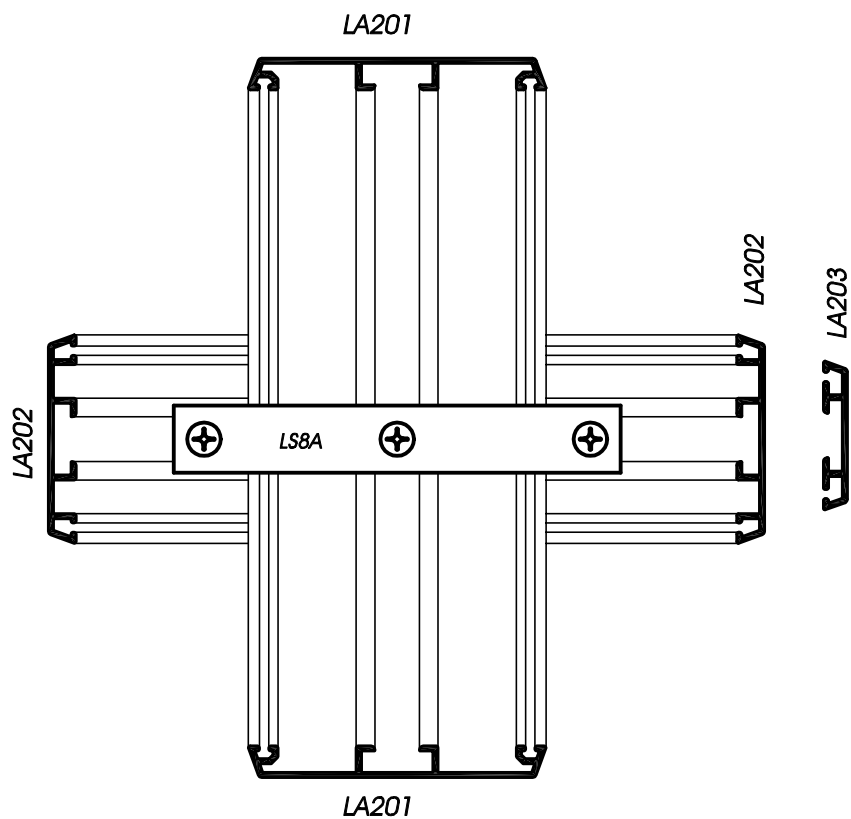

*Squadrette per accoppiamenti a croce*  
*Kreuzverbinder*  
*Escuadras para acoplamiento cruzados*  
*Equerres pour assemblage en croix*  
*Corner spigot for cross assembly*



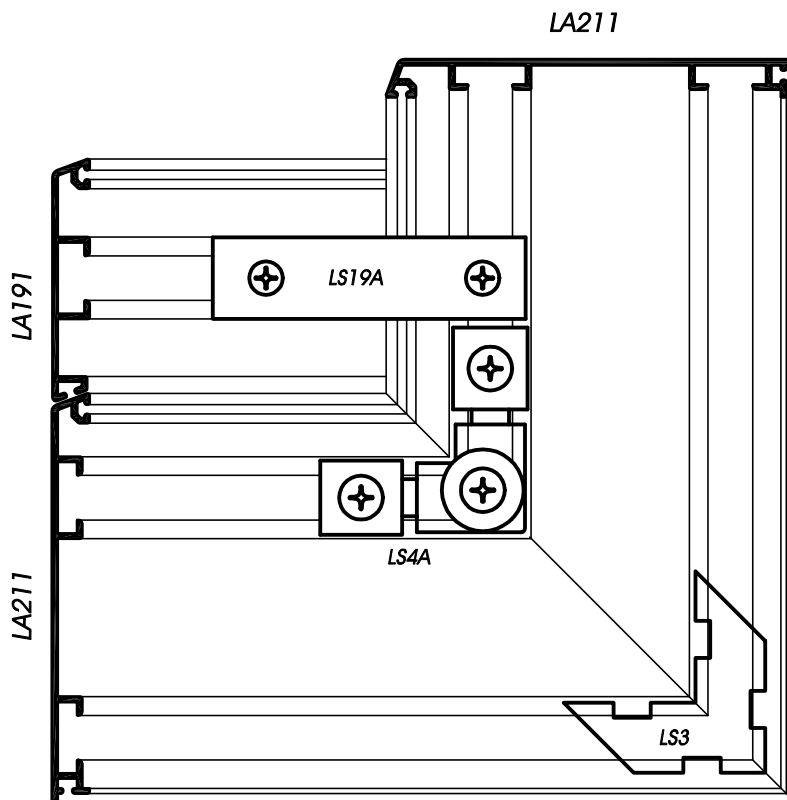
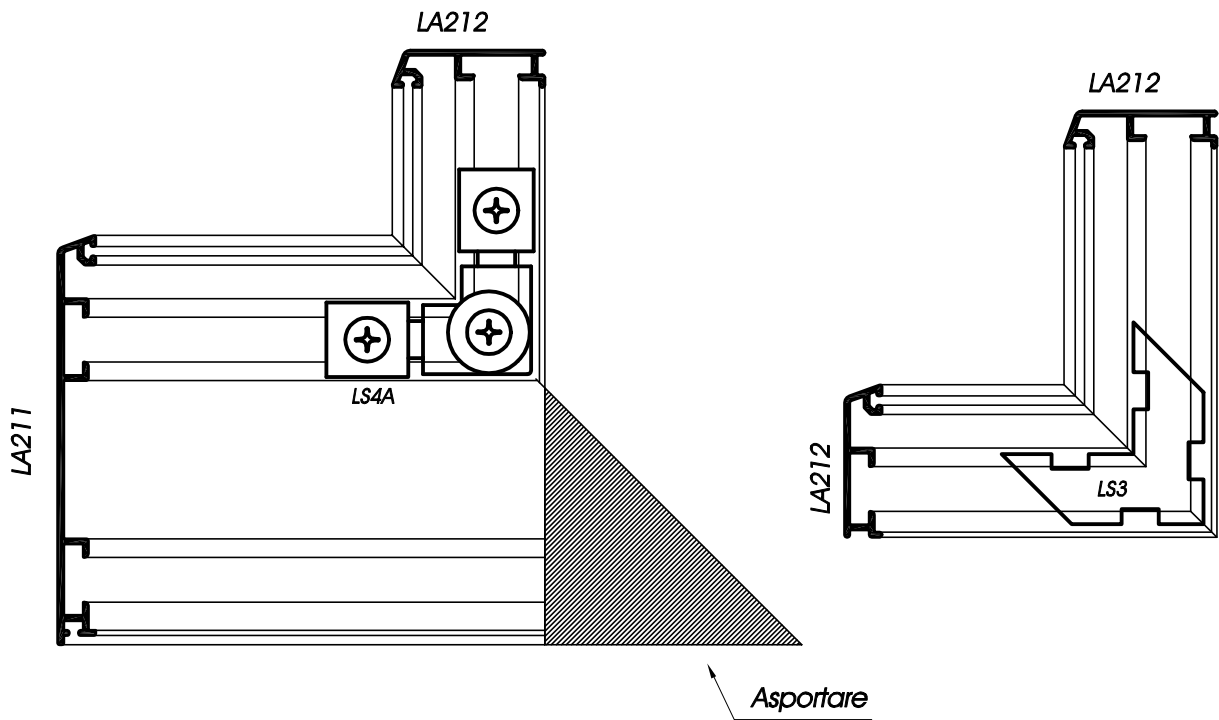

*Squadrette per profili alzante scorrevole*  
*Eckwinkel für Hebe-Schiebe-Türprofile*  
*Escuadras para corredera elevadora*  
*Equerres pour profils fenêtre levant-coulissante*  
*Corner spigot for sliding window-door's profiles*

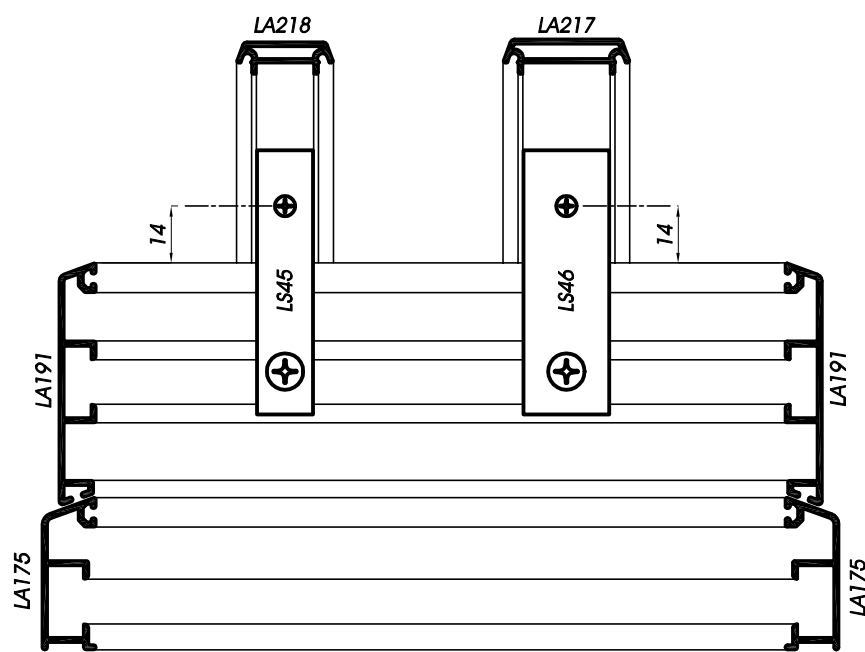
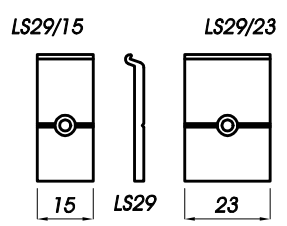
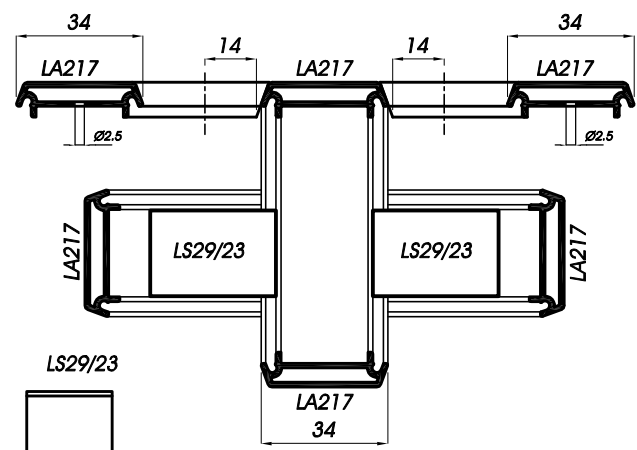
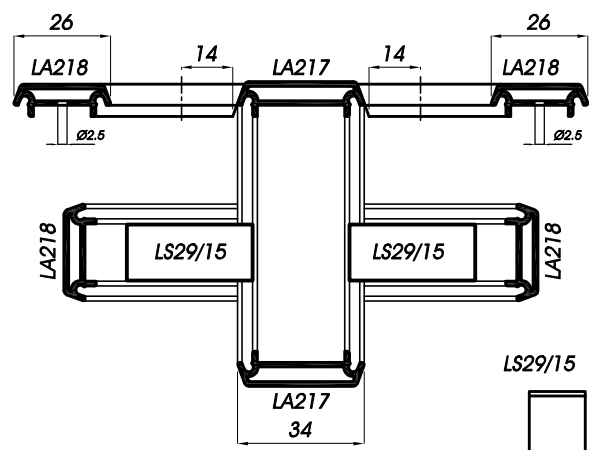
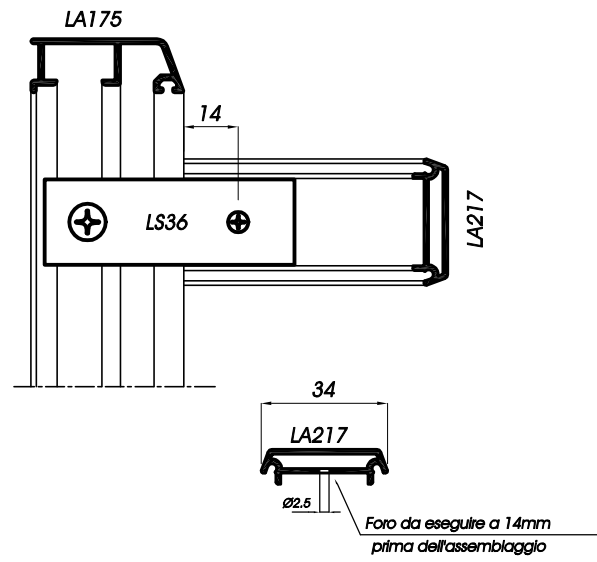
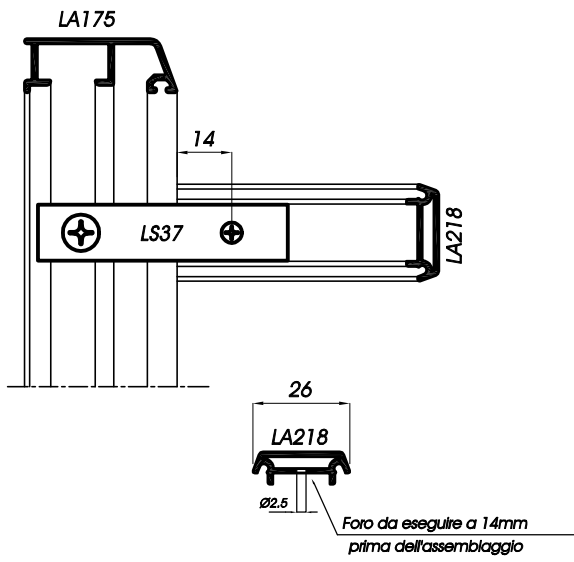

**Squadrette per accoppiamenti a croce**  
**Kreuzverbinder**  
**Escuadras para acoplamiento cruzados**  
**Equerres pour assemblage en croix**  
**Corner spigot for cross assembly**

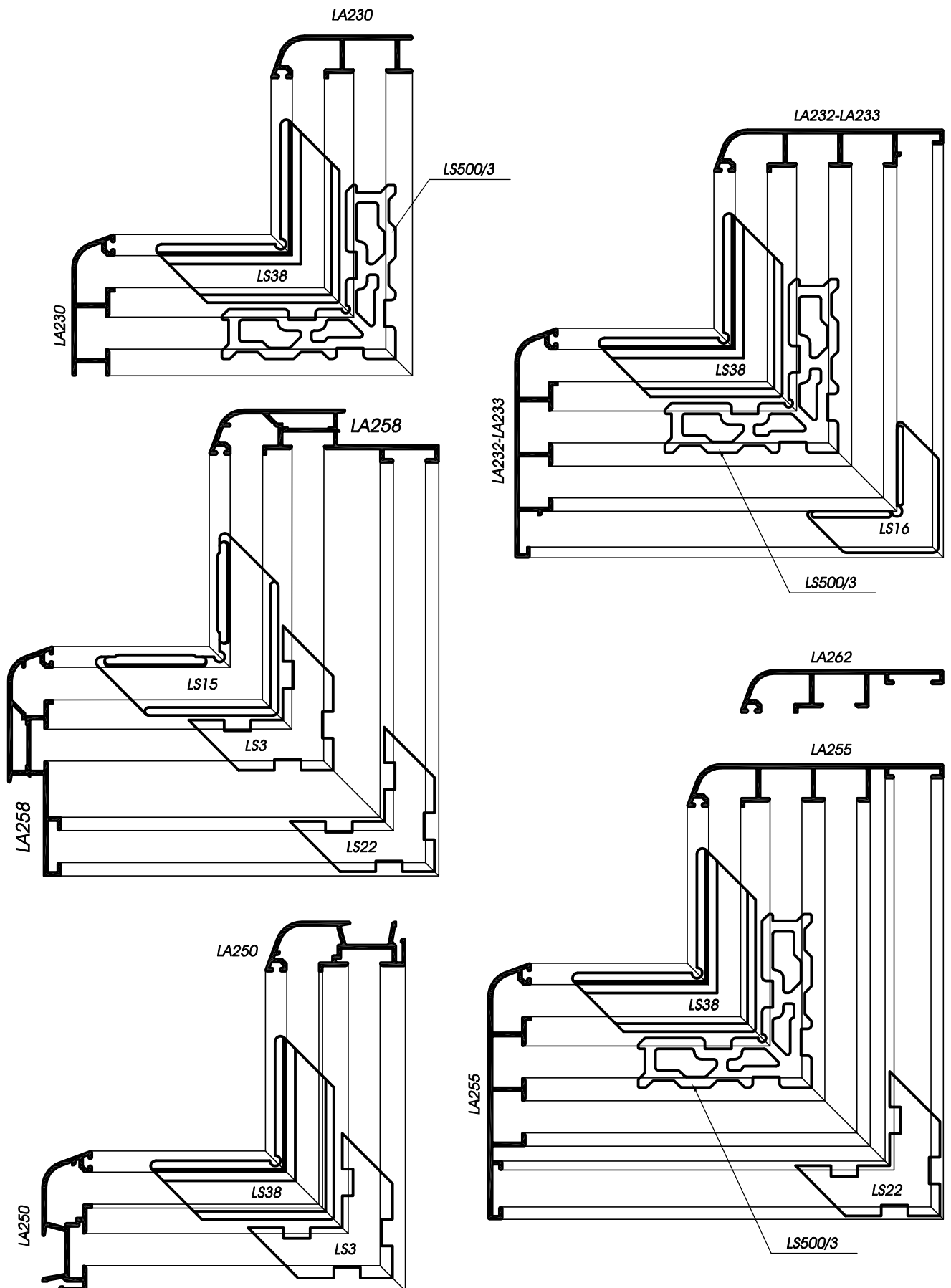

**Squadrette per profili telaio**  
**Eckwinkel für Rahmenprofile**  
**Escuadras para perfiles del marco**  
**Equerres pour profils dormant**  
**Corner spigot for frame's profiles**



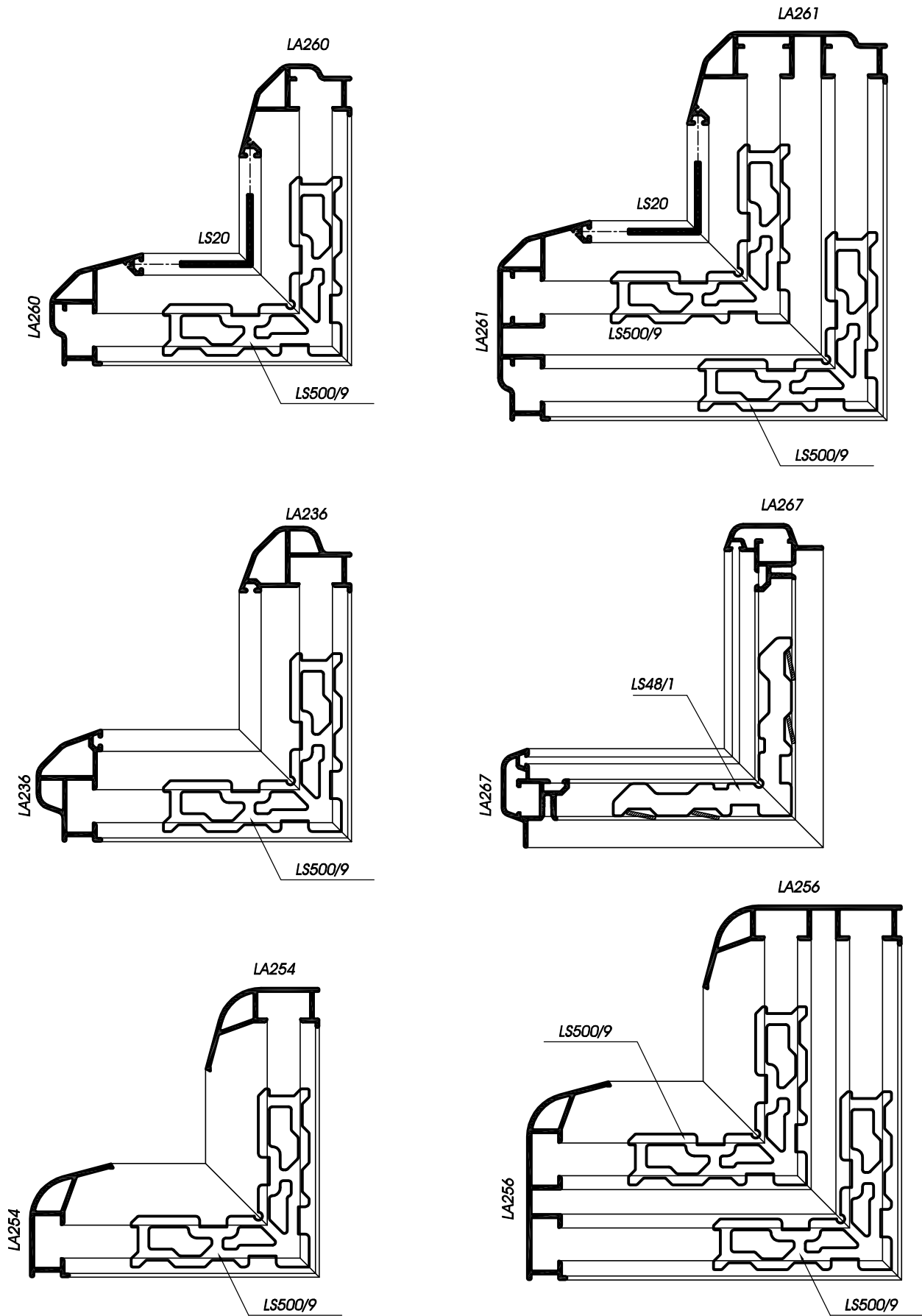

**Squadrette per profili anta**  
**Eckwinkel für Flügelprofile**  
**Escuadras para perfiles de la hoja**  
**Equerres pour profils vantaux**  
**Corner spigot for wing's profiles**

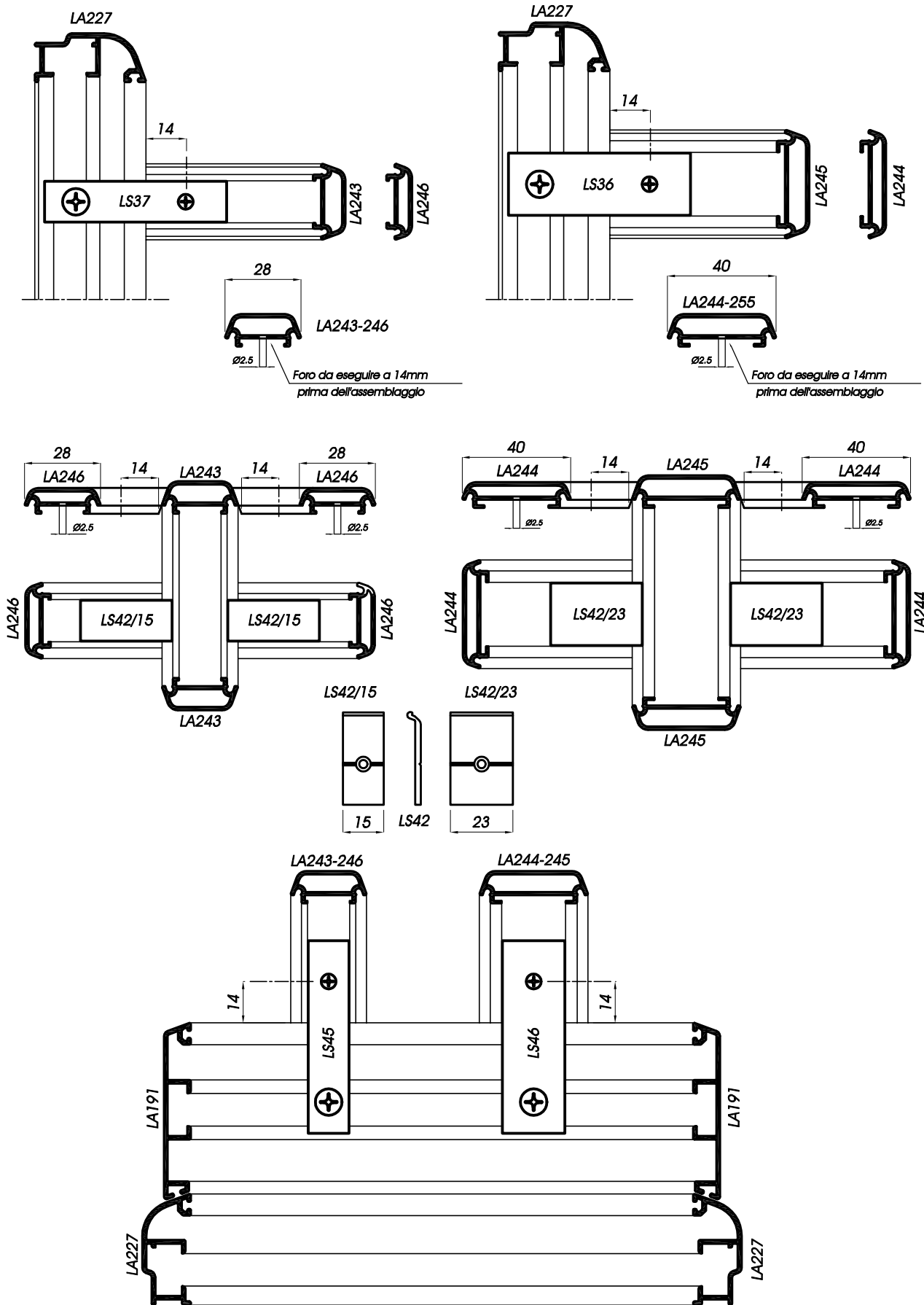

**Squadrette per accoppiamenti a croce**  
**Kreuzverbinder**  
**Escuadras para acoplamiento cruzados**  
**Equerres pour assemblage en croix**  
**Corner spigot for cross assembly**

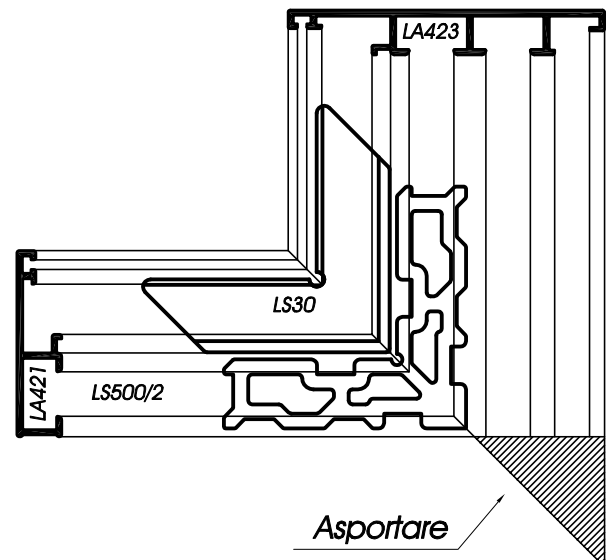
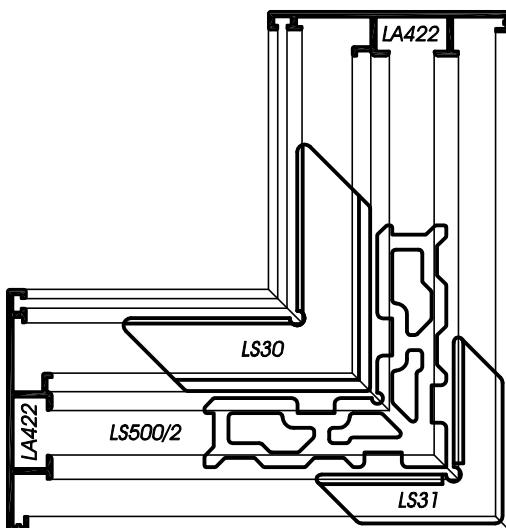
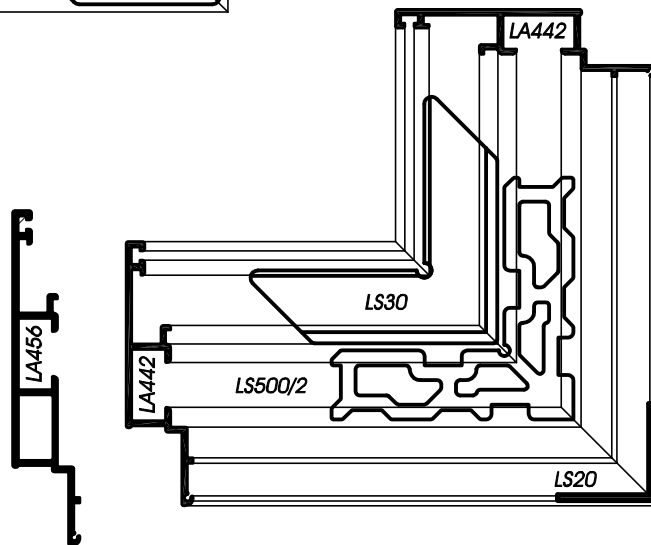
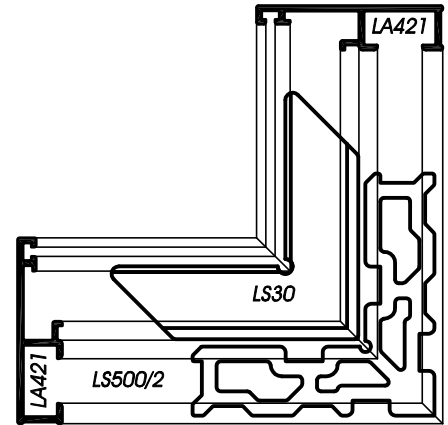
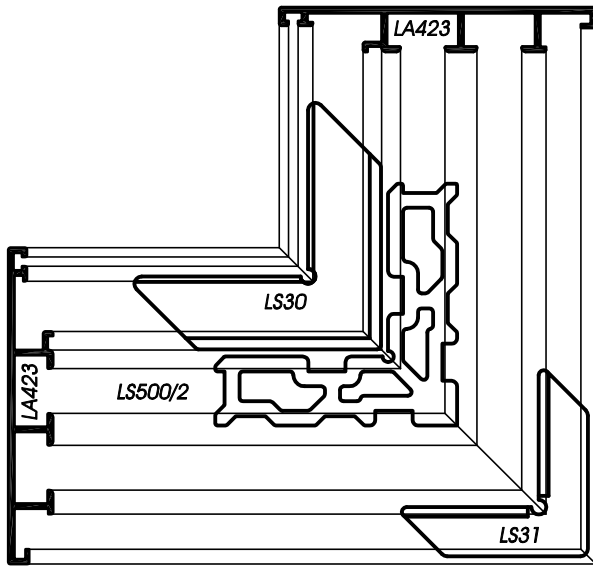

**Squadrette per profili telaio**  
**Eckwinkel für Rahmenprofile**  
**Escuadras para perfiles del marco**  
**Equerres pour profils dormant**  
**Corner spigot for frame's profiles**

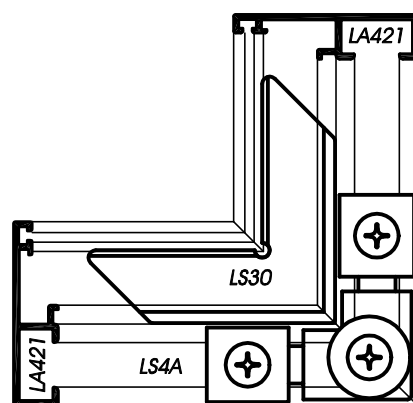
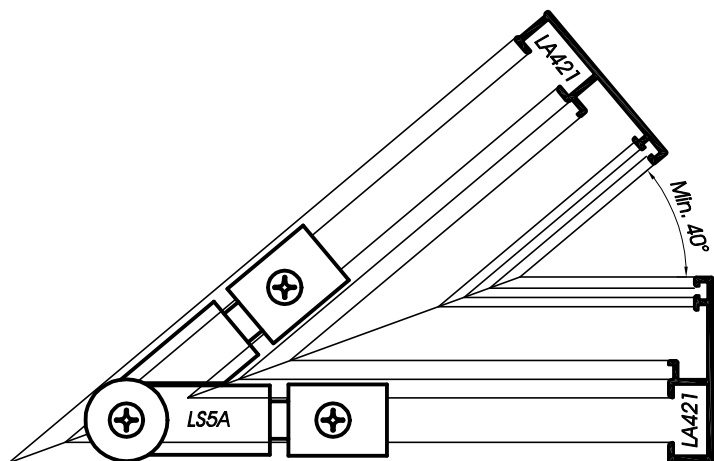
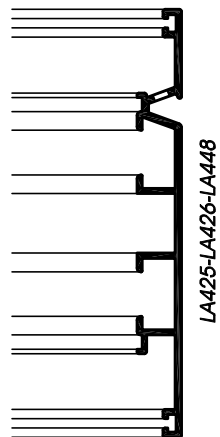
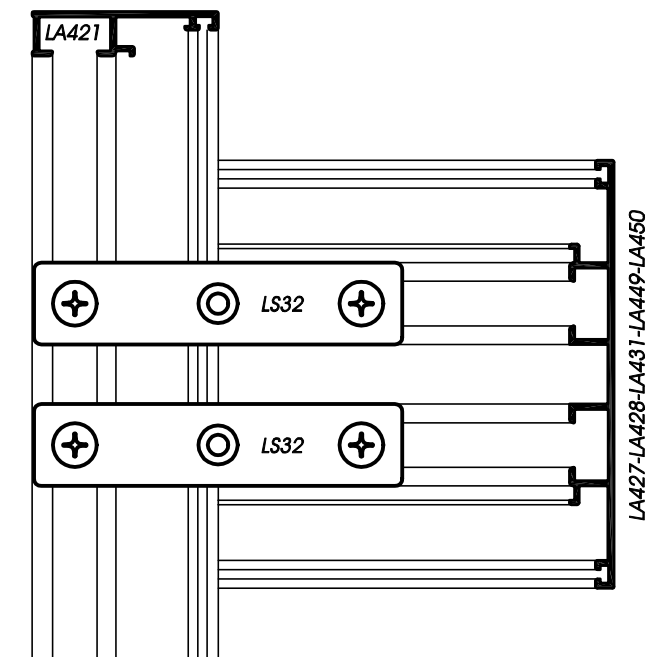

**Squadrette per profili telaio**  
**Eckwinkel für Rahmenprofile**  
**Escuadras para perfiles del marco**  
**Equerres pour profils dormant**  
**Corner spigot for frame's profiles**



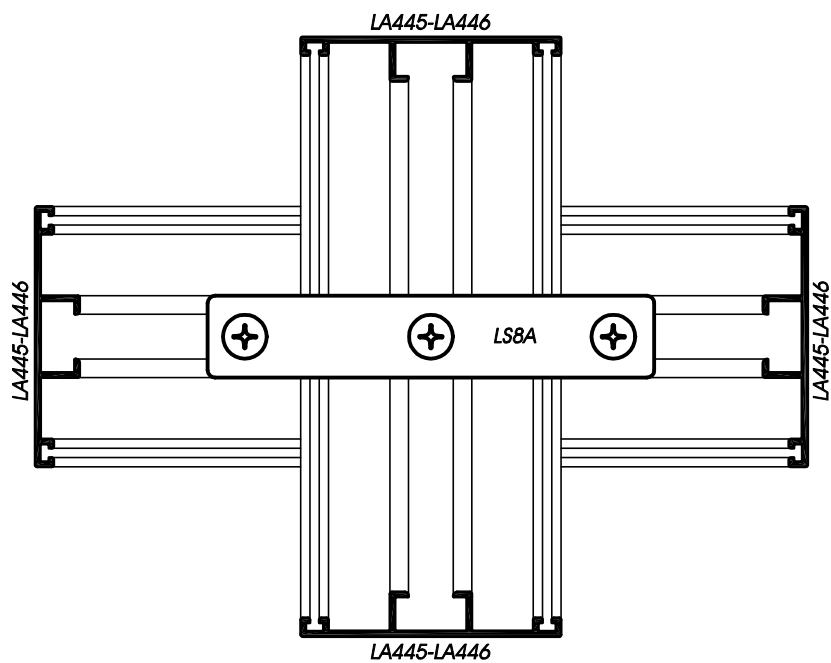
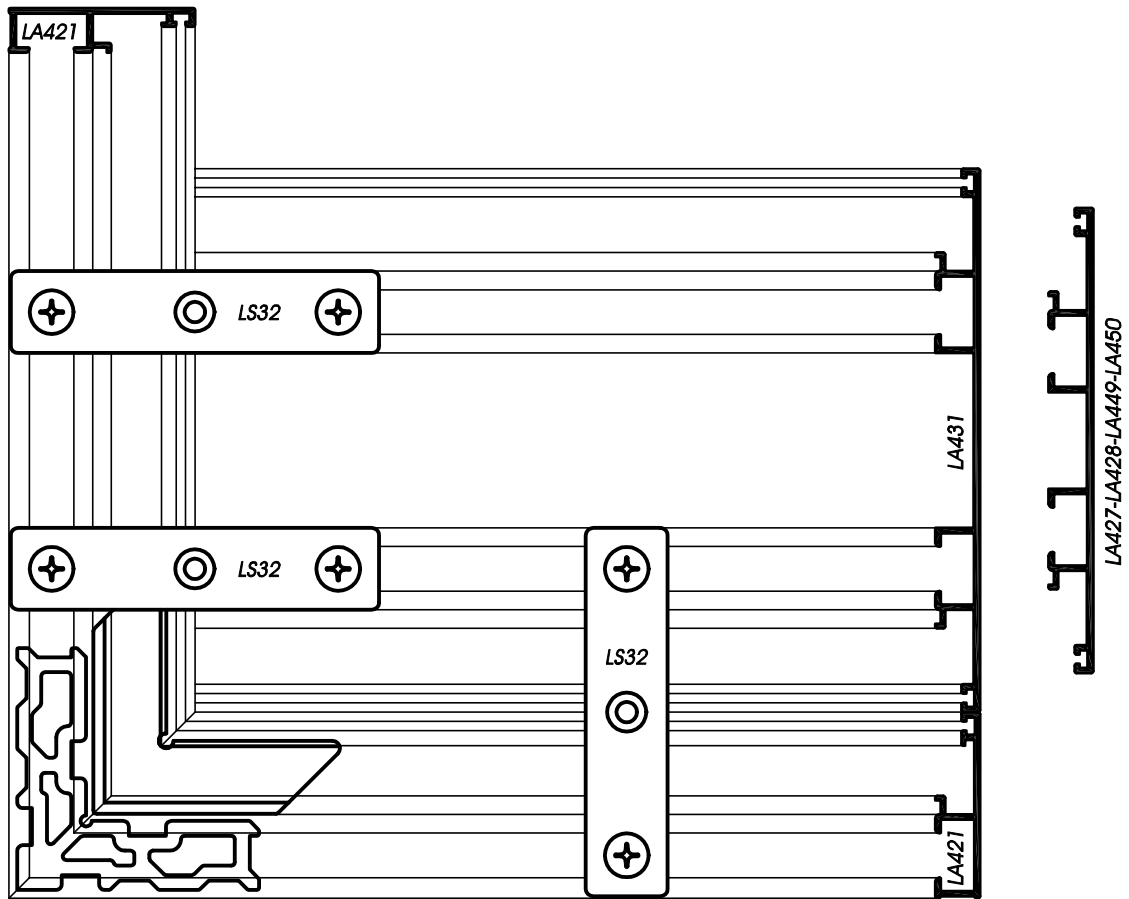

Squadrette per profili telaio  
 Eckwinkel für Rahmenprofile  
 Escuadras para perfiles del marco  
 Equerres pour profils dormant  
 Corner spigot for frame's profiles

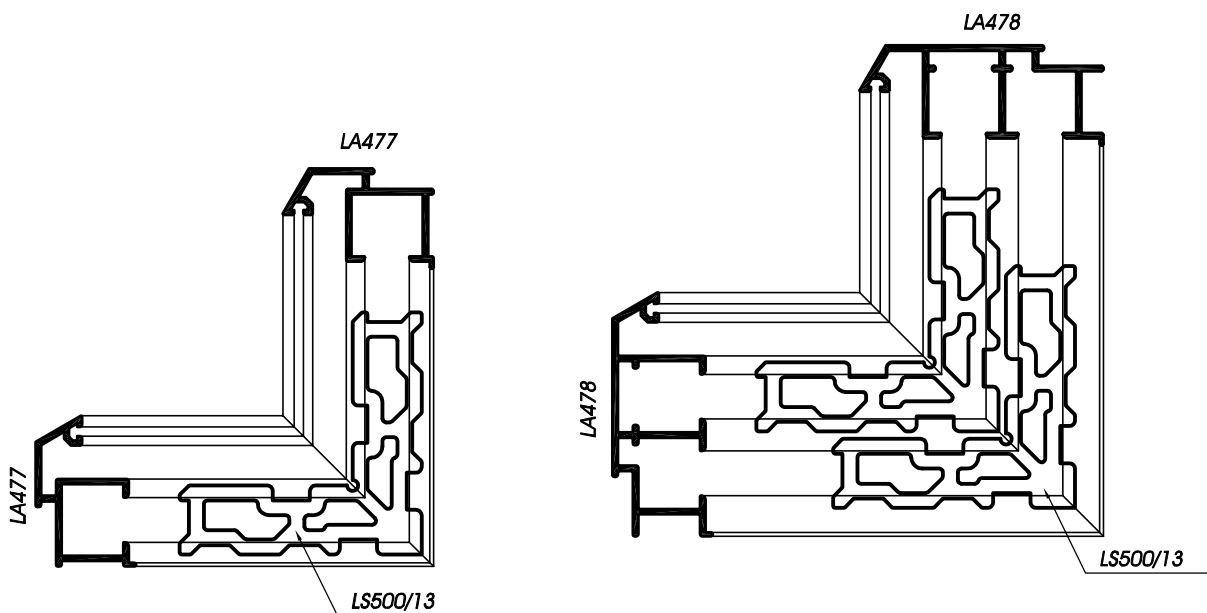
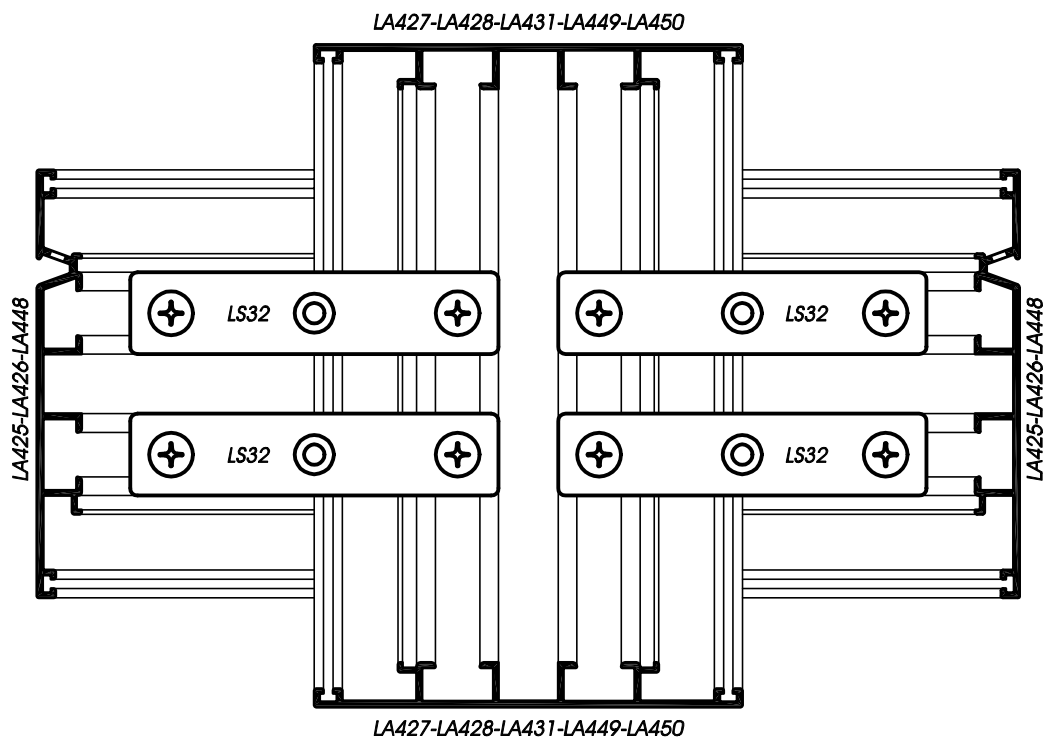

**Squadrette per accoppiamenti a croce e profili anta**  
**Kreuzverbinder und Flügelprofile**  
**Escuadras para acoplamiento cruzados y perfiles de la hoja**  
**Equerres pour assemblage en croix et profils vantaux**  
**Corner spigot for cross assembly and wing's profiles**

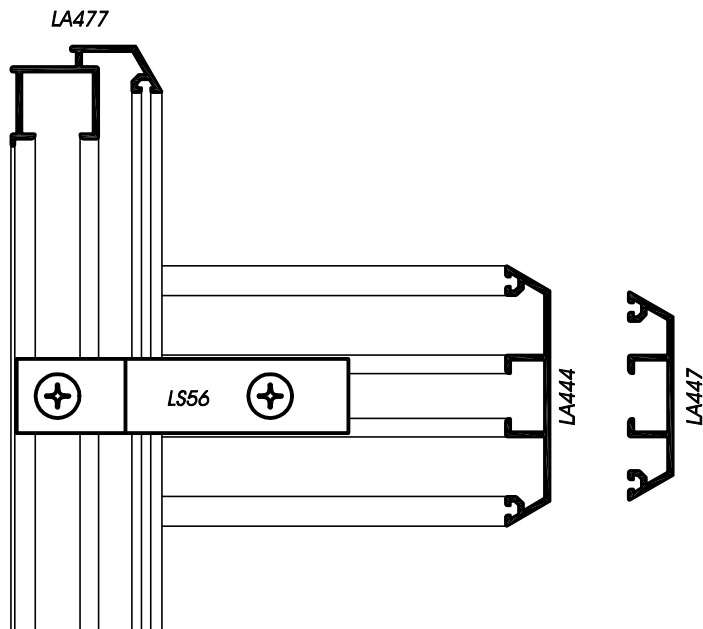
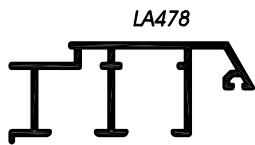
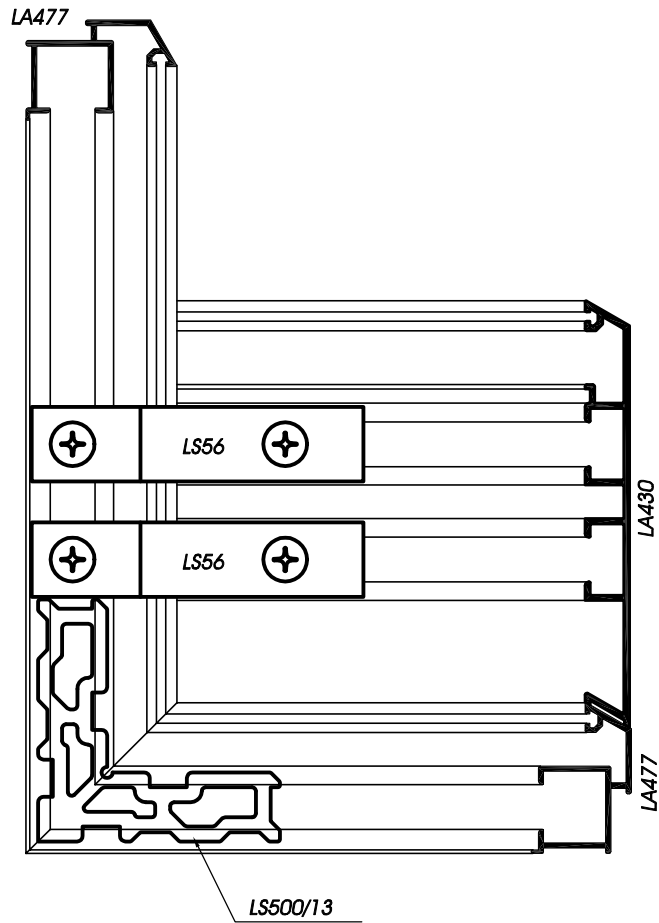

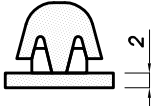
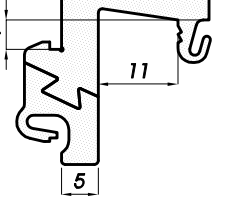
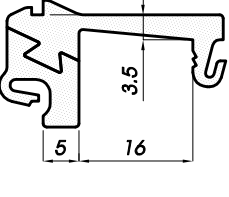
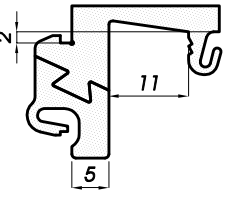
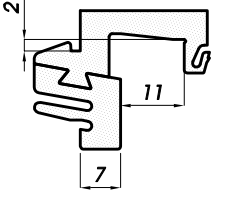
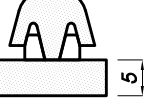
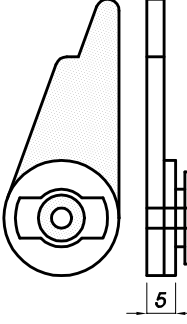
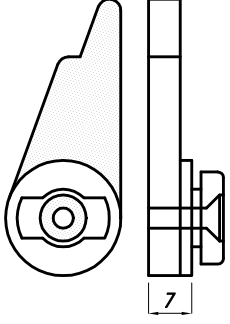
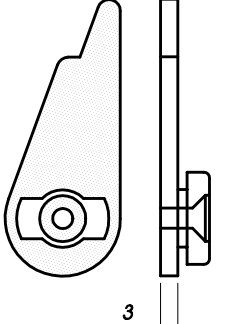
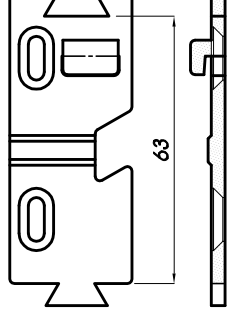
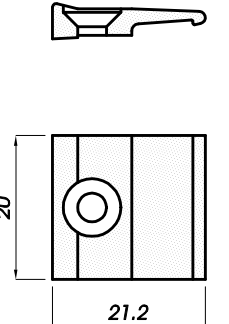
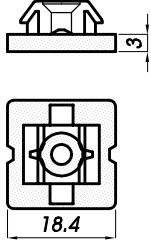
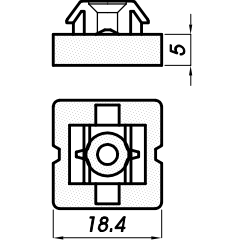
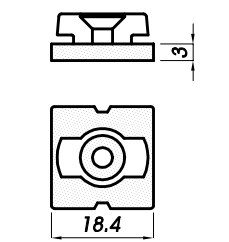
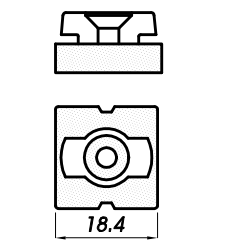
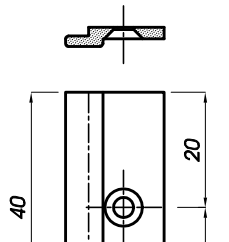

**Squadrette per profili anta**  
**Eckwinkel für Flügelprofile**  
**Escuadras para perfiles de la hoja**  
**Equerres pour profils vantaux**  
**Corner spigot for wing's profiles**

# CLIPS DI FISSAGGIO E ACCESSORI

<p><b>LC1</b></p>  <p>CLIPS A SCATTO sp. 2mm</p>	<p><b>LC3</b></p>  <p>CLIPS A SCATTO 5mm PER PROFILI ANTA - BATTUTA 18mm</p>	<p><b>LC13</b></p>  <p>CLIPS A SCATTO 5mm PER PROFILI ANTA - BATTUTA 20mm</p>	<p><b>LC24</b></p>  <p>CLIPS A SCATTO 5mm PER PROFILI ANTA - BATTUTA 20mm</p>	<p><b>LC31</b></p>  <p>CLIPS A SCATTO 7mm PER PROFILI ANTA - BATTUTA 20mm</p>
<p><b>LC2</b></p>  <p>CLIPS A SCATTO sp. 5mm</p>	<p>CLIPS A SCATTO 5mm PER PROFILI ANTA - BATTUTA 18mm</p>	<p>CLIPS A SCATTO 5mm PER PROFILI ANTA - BATTUTA 20mm</p>	<p>CLIPS A SCATTO 5mm PER PROFILI ANTA - BATTUTA 20mm</p>	<p>CLIPS A SCATTO 7mm PER PROFILI ANTA - BATTUTA 20mm</p>
<p><b>LC4</b></p>  <p>CLIPS GIREVOLE CON VITE Spessore 5mm</p>	<p><b>LC4/7</b></p>  <p>CLIPS GIREVOLE CON VITE Spessore 7mm</p>	<p><b>LC5</b></p>  <p>CLIPS GIREVOLE CON VITE Spessore 3mm</p>	<p><b>LC19</b></p>  <p>CLIPS MODULARE PER PROFILO LA191 (63mm)</p>	<p><b>LC251</b></p>  <p>CLIPS A SCATTO PER PROFILO LA251</p>
<p><b>LC18/3</b></p>  <p>CLIPS A SCATTO-GIREVOLE CON VITE - Spessore 3mm</p>	<p><b>LC18/5</b></p>  <p>CLIPS A SCATTO-GIREVOLE CON VITE - Spessore 5mm</p>	<p><b>LC26/3</b></p>  <p>CLIPS A SCATTO-GIREVOLE CON VITE - Spessore 3mm</p>	<p><b>LC26/5</b></p>  <p>CLIPS A SCATTO-GIREVOLE CON VITE - Spessore 5mm</p>	<p><b>LC7</b></p>  <p>CLIPS PER PROFILI LA102 LA114-LA115-LA161</p>
<p><b>LC18/3-M</b></p> <p>Clips in contenitore da 66pz per attrezzatura di montaggio automatico -STRIFLER</p>	<p><b>LC18/5-M</b></p> <p>Clips in contenitore da 54pz per attrezzatura di montaggio automatico -STRIFLER</p>	<p><b>LC26/3-M</b></p> <p>Clips in contenitore da __pz per attrezzatura di montaggio automatico -STRIFLER</p>	<p><b>LC26/5-M</b></p> <p>Clips in contenitore da __pz per attrezzatura di montaggio automatico -STRIFLER</p>	<p>CLIPS PER PROFILI LA102 LA114-LA115-LA161</p>

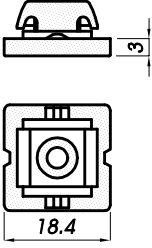
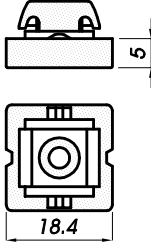
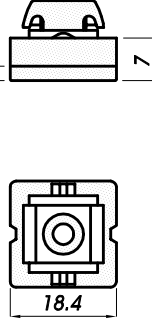
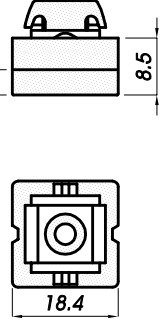
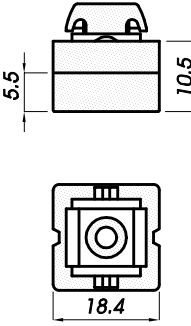
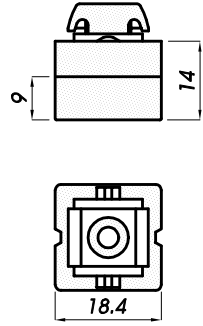
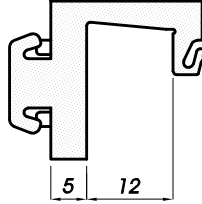
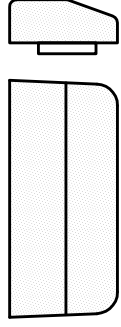
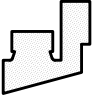

Clips di fissaggio e accessori  
 Befestigungsklips und Zubehör  
 Clips de fijación y accesorios  
 Clips de fixation et accessoires  
 Fixing clips and spare-parts

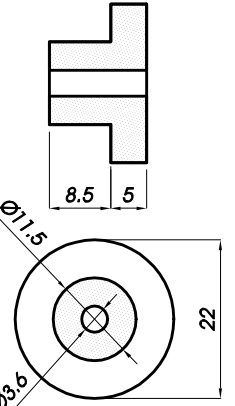
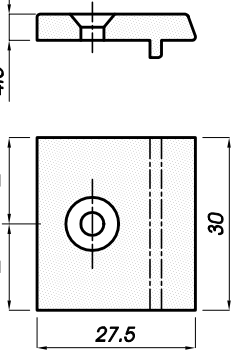
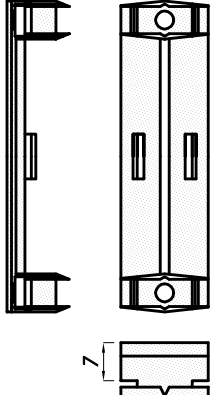
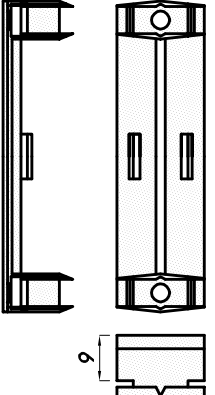
# CLIPS DI FISSAGGIO E ACCESSORI

<p><b>LCZ-1</b> SPESSORE 1mm PER CLIPS</p> <p><b>LCZ-2</b> SPESSORE 2mm PER CLIPS</p> <p><b>LCZ-3.5</b> SPESSORE 3.5mm PER CLIPS</p> <p><b>LCZ-5.5</b> SPESSORE 5.5mm PER CLIPS</p> <p><b>LCZ-9</b> SPESSORE 9mm PER CLIPS</p>	<p><b>LC27/3-V</b></p>  <p>CLIPS A SCATTO-GIREVOLE FORNITA CON VITE LVP30</p> <p><b>LC27/3-M</b></p> <p>Clips in contenitore da 62pz per attrezzatura di montaggio automatico</p>	<p><b>LC27/5-V</b></p>  <p>CLIPS A SCATTO-GIREVOLE FORNITA CON VITE LVP30</p> <p><b>LC27/3-M</b></p> <p>Clips in contenitore da 51pz per attrezzatura di montaggio automatico</p>	<p><b>LC27/7</b></p>  <p>CLIPS A SCATTO-GIREVOLE LC27/5 con spessore LCZ-2</p>	<p><b>LC27/8.5</b></p>  <p>CLIPS A SCATTO-GIREVOLE LC27/5 con spessore LCZ-3.5</p>
<p><b>LC27/10.5</b></p>  <p>CLIPS A SCATTO-GIREVOLE LC27/5 con spessore LCZ-5.5</p>	<p><b>LC27/14</b></p>  <p>CLIPS A SCATTO-GIREVOLE LC27/5 con spessore LCZ-9</p>	<p><b>LC25</b></p>  <p>CLIPS A SCATTO PER TELAIO SPESSORE 5mm</p>	<p><b>LC11</b></p>  <p>TAPPI PER SCARICO ACQUA FRONTALE</p>	
<p><b>LC12/A</b></p> <p>TERMINALE PER LA149C+LA162</p>  <p><b>LC28</b></p> <p>TERMINALE PER LB02C+LB04</p>  <p><b>LC230</b></p> <p>TERMINALE PER LA230C+LA231</p> 	<p><b>LC21</b></p>  <p>BLOCCHETTO DI RINFORZO PER PORTEFINESTRE</p>	<p><b>LC22</b></p>  <p>FERMO DI SICUREZZA PER BLOCCAGGIO VETRO</p>	<p><b>LC23/7</b></p>  <p>CONVOGIATORE ACQUA PER PROFILO LA181</p>	<p><b>LC23/9</b></p>  <p>CONVOGIATORE ACQUA PER PROFILO LA442-LA456</p>

**Clips di fissaggio e accessori**  
**Befestigungsklips und Zubehör**  
**Clips de fijación y accesorios**  
**Clips de fixation et accessoires**  
**Fixing clips and spare-parts**

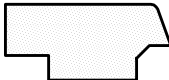
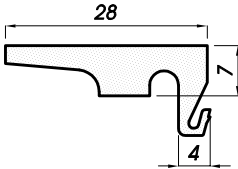
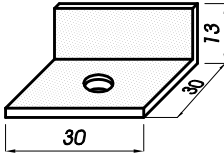
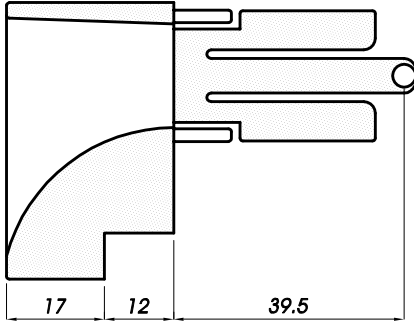
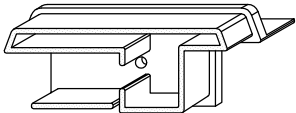
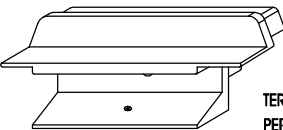
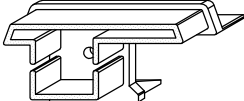
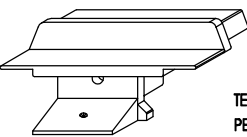
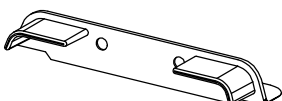
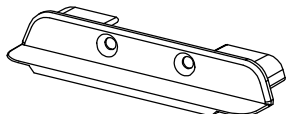
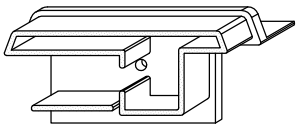
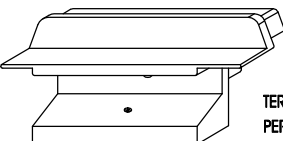
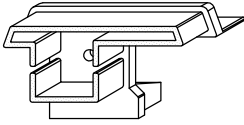
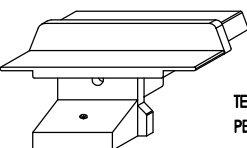
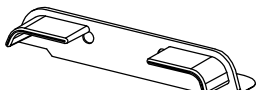
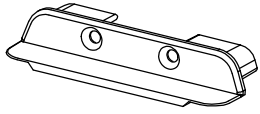
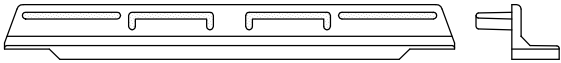
# ACCESSORI E TERMINALI

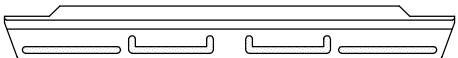
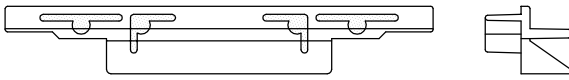
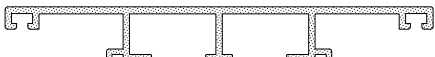
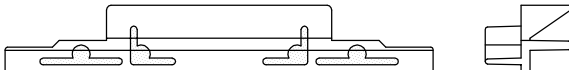
<p><b>LC29</b></p>	<p><b>LC46</b></p>	<p><b>LS49</b></p>	<p><b>LGT Dx-Sx</b> TERMINALI PER GIUDE AVVOLGIBILI</p>
 <p>TAPPO DI CHIUSURA PER TRAVERSI TELAIO</p>	 <p>SUPPORTO VETRO PER SISTEMA 5000/S COMPLANARE</p>	 <p>SQUADRETTA DI STABILIZZAZIONE PER VETRI FISSI</p>	
<p><b>LC179 Dx-Sx</b></p>   <p>TERMINALI Dx - Sx PER PROFILO LA179</p>	<p><b>LC180 Dx-Sx</b></p>   <p>TERMINALI Dx - Sx PER PROFILO LA180</p>	<p><b>LC247 Dx-Sx</b></p>   <p>TERMINALI Dx - Sx PER PROFILO LA247</p>	
<p><b>LC263 Dx-Sx</b></p>   <p>TERMINALI Dx - Sx PER PROFILO LA263</p>	<p><b>LC264 Dx-Sx</b></p>   <p>TERMINALI Dx - Sx PER PROFILO LA264</p>	<p><b>LC268 Dx-Sx</b></p>   <p>TERMINALI Dx - Sx PER PROFILO LA268</p>	
<p><b>LC224</b> TERMINALI PER PROFILO LA224</p>   	<p><b>LC450</b> TERMINALI PER PROFILO LA450</p>   		

**Accessori e terminali per profili**  
**Zubehör und Stulpkappen für profile**  
**Accesorios y terminales para perfiles**  
**Equerres et embouts pour profils**  
**Spare-parts and terminals for profiles**

# TERMINALI

LC319/45

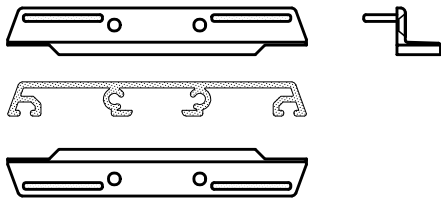

TERMINALI  
PER PROFILO LA319

LC476/A

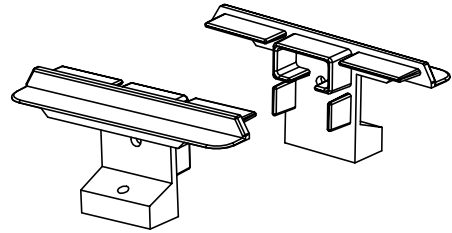

TERMINALI  
PER PROFILO LA476

LC35

TERMINALI  
PER PROFILO IN BRONZO LB15

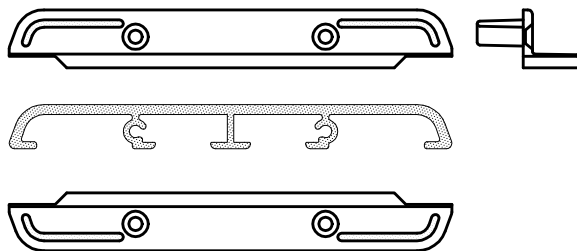

LC626

TERMINALI  
PER PROFILO LA626

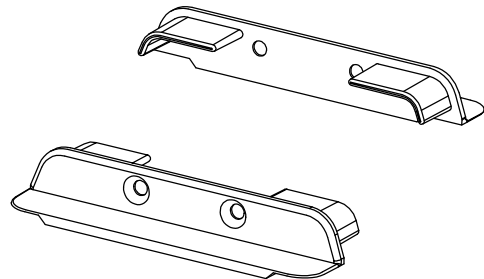

LC226 Dx-Sx

TERMINALI Dx - Sx  
PER PROFILO LA226 - LA273

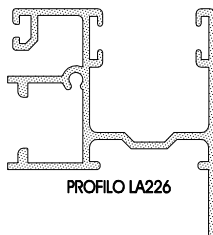
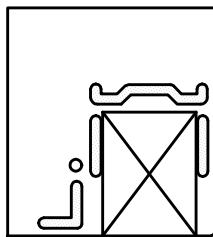

PROFILO LA226

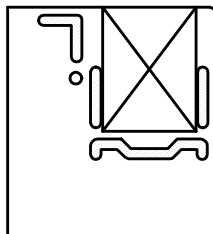





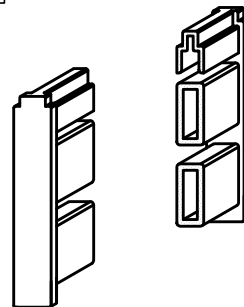







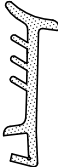
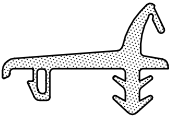
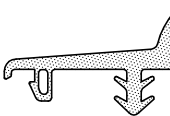
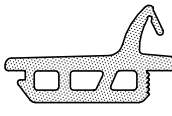
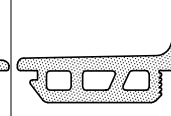

LC602

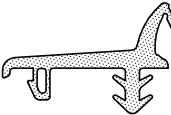
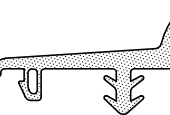
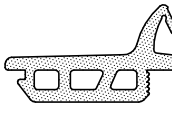
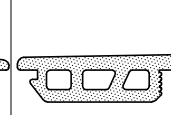
TERMINALI Dx - Sx  
PER PROFILO LA613

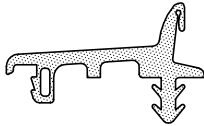

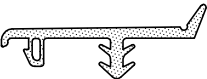
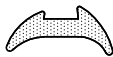
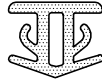
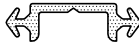
Terminali per profili  
Stulpkappen für profile  
Terminales para perfiles  
Embouts pour profils  
Terminals for profiles

# GUARNIZIONI

<p><b>DE34</b> Aia 3mm</p> 	<p><b>DE29</b></p> 	<p><b>DE32</b></p> 	<p><b>DE51</b> aia 2mm</p> <p><b>DE52</b> aia 3mm</p> <p><b>DE56</b> aia 4mm</p> 	<p><b>DE04s</b></p> 	<p><b>DR01/15</b> Battuta 15mm</p> <p><b>DR01/18</b> Battuta 18mm</p> <p><b>DR01/20</b> Battuta 20mm</p> 
<p><b>DE41</b> Aia 4.5mm</p> <p>Guarnizione profilo vetro Materiale: EPDM espanso Colore: NERO</p>	<p>Guarnizione profilo vetro Materiale: EPDM espanso Colore: NERO</p>	<p>Guarnizione per silconatura vetro Materiale: EPDM Colore: NERO</p>	<p>Guarnizione per battuta vetro Materiale: TPE Colore: NERO</p>	<p>Guarnizione per profili aggiuntivi Materiale: TPE Colore: NERO</p>	<p>Guarnizione per battuta ferma vetro Materiale: TPE Colore: NERO-MARRONE</p>
<p><b>DE27</b> per battuta 15mm</p>  <p>Guarnizione telaio Materiale: EPDM Colore: NERO</p>	<p><b>DE28</b> per battuta 15mm</p>  <p>Guarnizione telaio Materiale: EPDM Colore: NERO</p>	<p><b>DE43</b> per battuta 15mm</p>  <p>Guarnizione telaio Materiale: EPDM Colore: NERO</p>	<p><b>DE54</b> per battuta 15mm</p>  <p>Guarnizione telaio Materiale: EPDM Colore: NERO</p>	<p><b>DE30</b></p>  <p>Guarnizione per chiusura centrale Materiale: EPDM Colore: NERO</p>	<p><b>DE402</b></p>  <p>Guarnizione per chiusura centrale Materiale: EPDM Colore: NERO</p>
<p><b>DE59</b> per battuta 17mm</p>  <p>Guarnizione telaio Materiale: EPDM Colore: NERO</p>	<p><b>DE60</b> per battuta 17mm</p>  <p>Guarnizione telaio Materiale: EPDM Colore: NERO</p>	<p><b>DE57</b> per battuta 17mm</p>  <p>Guarnizione telaio Materiale: EPDM Colore: NERO</p>	<p><b>DE58</b> per battuta 17mm</p>  <p>Guarnizione telaio Materiale: EPDM Colore: NERO</p>	<p><b>DE08</b></p>  <p>Guarnizione per chiusura centrale Materiale: EPDM Colore: NERO</p>	<p><b>DE81</b></p>  <p>Guarnizione telaio Materiale: EPDM Colore: NERO</p>
<p><b>DE82</b> con clips LC25 sul telaio</p>  <p>Guarnizione per fisso con clips a scatto sul telaio Materiale: EPDM Colore: NERO</p>	<p><b>DE31</b></p>  <p>Guarnizione per vetro fisso Materiale: EPDM Colore: NERO</p>	<p><b>DE10</b></p>  <p>Guarnizione per lamiera piane Materiale: TPE Colore: NERO</p>	<p><b>DE25</b></p>  <p>Guarnizione per accoppiamento telai Materiale: TPE Colore: NERO</p>	<p><b>DE26</b></p>  <p>Guarnizione per accoppiamento telai Materiale: TPE Colore: NERO</p>	<p><b>DE38</b></p>  <p>Guarnizione per alzanfi scorrevoli Materiale: EPDM Colore: NERO</p>
<p><b>DE49</b></p> <p>Guarnizione per VERBUND 5000/S Materiale: EPDM Colore: NERO</p> 		<p><b>DE50</b></p> <p>Guarnizione per VERBUND 5000/S Materiale: EPDM Colore: NERO</p> 		<p><b>DE64</b></p> <p>Guarnizione per VERBUND Soft-Line Materiale: EPDM Colore: NERO</p> 	

**Guarnizioni**  
**Dichtung**  
**Juntas**  
**Joints**  
**Gaskets**



## NASTRI A COMPRESSIONE

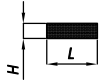

Codice	L	H
LG10/3	10	3
LG15/3	15	3
LG20/6	20	6
LG20/8	20	8
LG20/10	20	10
LG30/5	30	5

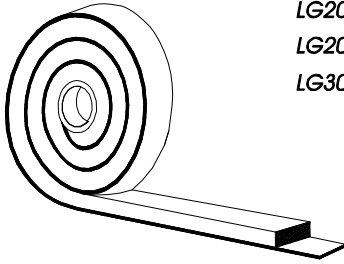

## NASTRI AD ESPANSIONE

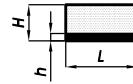

Codice	L	H	h
GE10/10	10	10	2
GE15/15	15	15	3
GE15/20	15	20	4
GE20/10	20	10	2
GE20/20	20	20	4

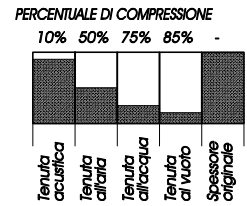
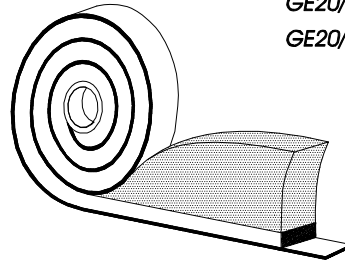

LCN19

Biadesivo per LA137-198

LCTenax

Colla per metalli 300ml

LC640

Sigillante verniciabile

LCPROTEX

Anticorrosivo per alluminio

LC-TER90

Sigillante poliuretano

- I** Per il corretto impiego delle clips LC3-LC13-LC24 è indispensabile che il foro indicato con A, sia chiuso. Se non è previsto dalla tenonatura, è necessario eseguire un'accurata silconatura.
- D** Bei der Verarbeitung des Halters LC3-LC13-LC24 ist unbedingt die dafür notwendige Aufnahme zu abzukontem. Bei Schlitzwerkzeugen ohne Konterfräsung, ist das in beiliegender Zeichnung unter Punkt "A" gekennzeichnete Loch, mit Silikonmasse abzudichten.
- E** Para el correcto empleo de los clips LC3-LC13-LC24 es indispensable que el hueco "A" esté cerrado lateralmente. En caso de que el espigado no lo prevea, es necesario cerrarlo herméticamente con silicona.
- F** Pour un correct placement des clips LC3-LC13-LC24 il est nécessaire que le trou indiqué au point A soit fermé. S'il n'est pas prévu par le tenonage, il est nécessaire d'effectuer un silconage soigné.
- GB** For the correct using of the clips LC3-LC13-LC24 is required that the hole with A shown is closed. If it is not forecasted by the tenoning, is necessary to perform an adequate silicone-working.

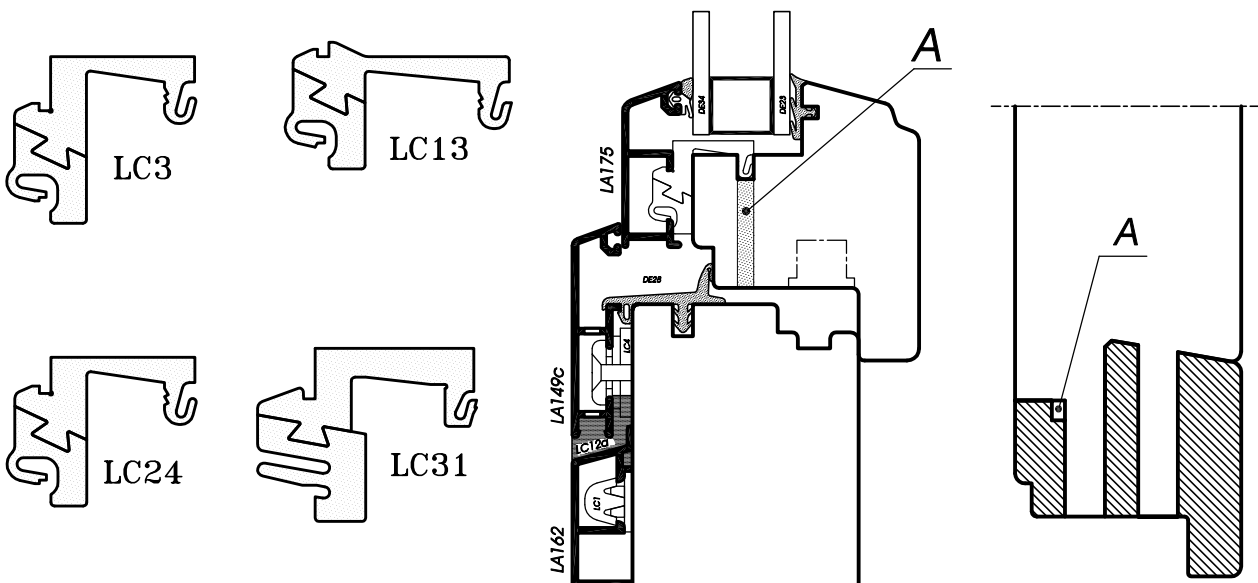

Nastri di tenuta - Sigillatura ante  
 Klebebänder - Dichtung Flügel  
 Cintas de estanqueidad - Selladura de las hojas  
 Rubans pour isolation - Etancher avec du silicone  
 Sealed wings

## Angolo Vulcanizzato DE27/E e DE28/E

### Modalità d'impiego:

Inserire gli angoli DE27/E o DE28/E sul telaio.

Tagliare la guarnizione DE27 o DE28 a 90° con misura pari a Interno telaio - 100 mm.

Incollare con collante cianoacrilico elastomerico tipo: (Loctite 480) o similari.

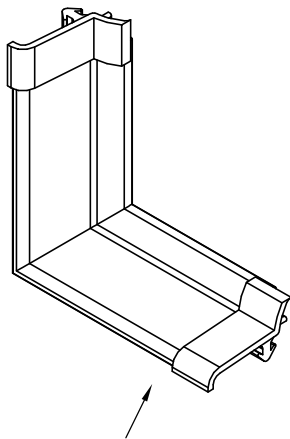

Aletta per incollaggio  
guarnizione DE27 o DE28

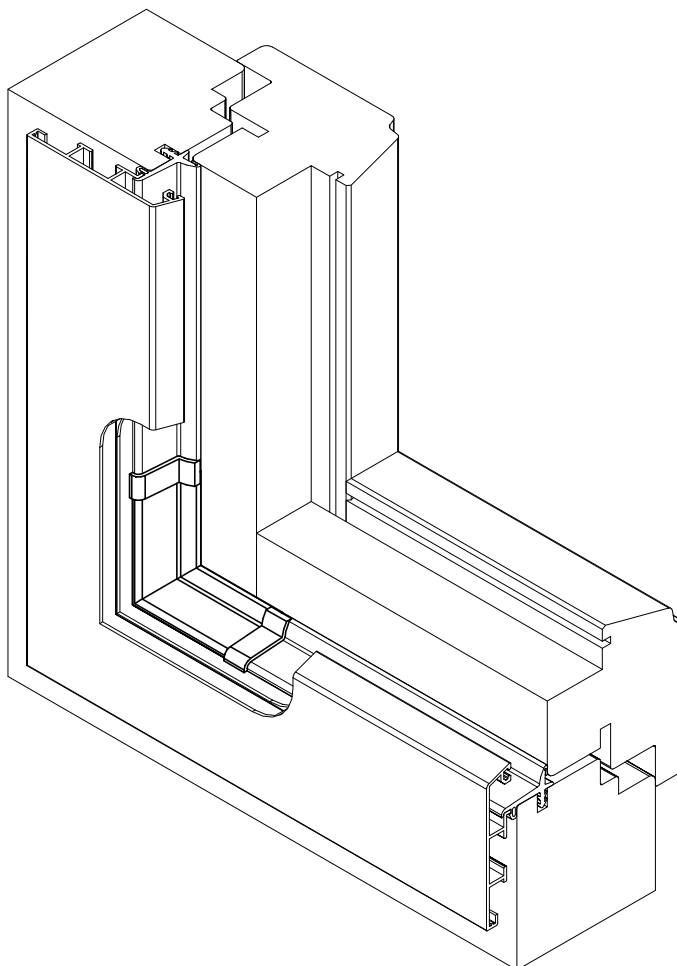

DE27/R o DE28/R: telaio  
vulcanizzato a misura

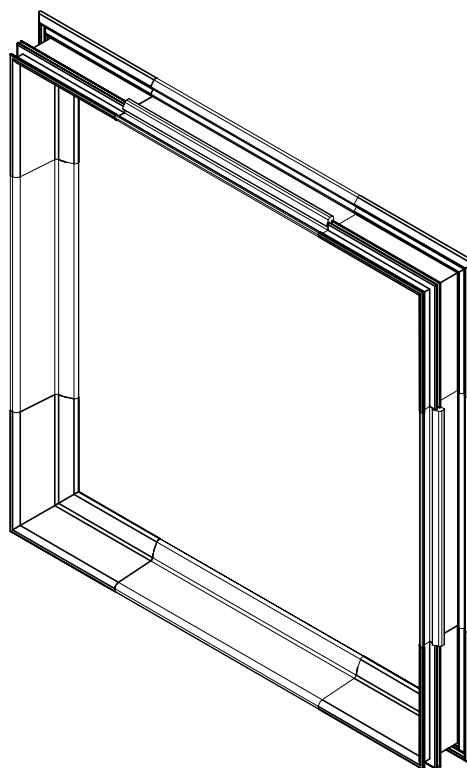
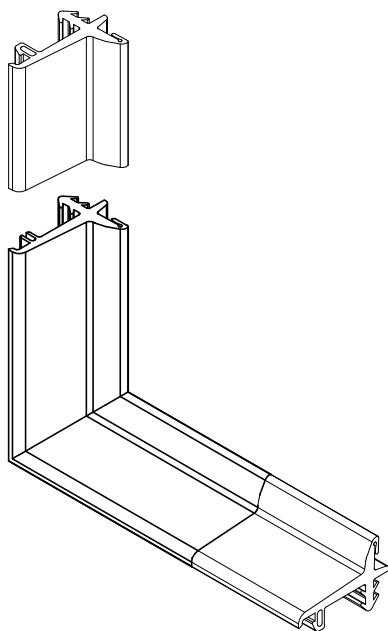

**Guarnizione DE27 - DE28**  
**Dichtung DE27 - DE28**  
**Junta DE27 - DE28**  
**Joint DE27 - DE28**  
**Gasket DE27-DE28**

# ATTREZZATURA PER TAGLIO GUARNIZIONI

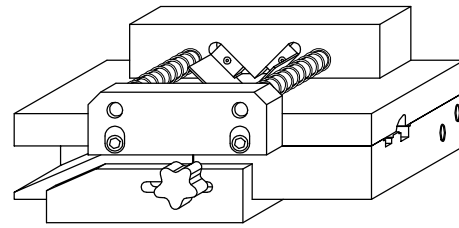
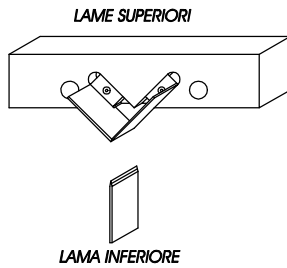

**FASE -1-**

**FASE -2-**

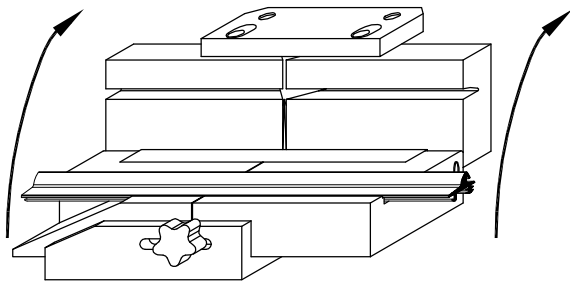

APRIRE E INSERIRE  
LA GUARNIZIONE

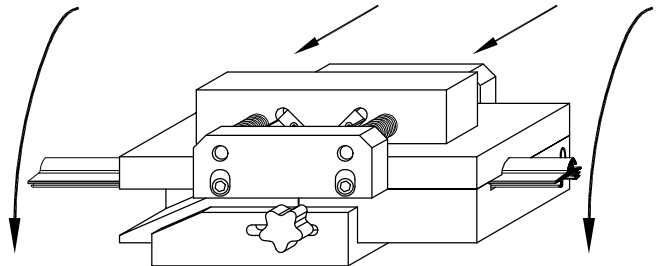

RICHIUDERE E AZIONARE  
LA SLITTA PORTALAME PER  
TAGLIARE LA GUARNIZIONE

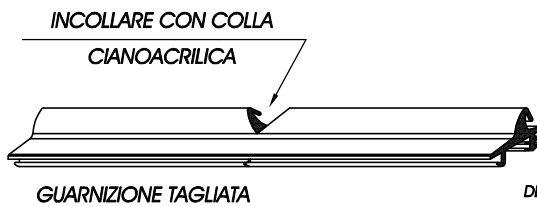

RUOTARE LA GUARNIZIONE  
DI 90° E INSERIRE NEL TELAIO  
DOPO AVER SILICONATO  
L'INCASTRO SULL'ANGOLO

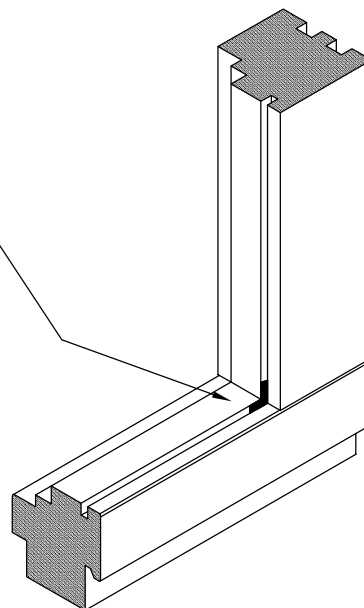

**LF6**

ATTREZZATURA PER TAGLIO DE27 e DE

**LF7**

ATTREZZATURA PER TAGLIO DE28

**LF8**

ATTREZZATURA PER TAGLIO DE43

**LF12**

ATTREZZATURA PER TAGLIO DE54

**LF13**

ATTREZZATURA PER TAGLIO DE57

**LF14**

ATTREZZATURA PER TAGLIO DE58

**LF15**

ATTREZZATURA PER TAGLIO DE59

**LF16**

ATTREZZATURA PER TAGLIO DE60

**LF18**

ATTREZZATURA PER TAGLIO DE81

**Attrezzatura per il taglio guarnizioni telaio**  
**Schere für Rahmendichtung**  
**Herramienta para cortar las juntas del marco**  
**Outillage pour la coupe du joint dormant**  
**Special equipment for the cut of the frame's gaskets**

## ATTREZZATURA PER TAGLIO GUARNIZIONI CON ASTA LF10

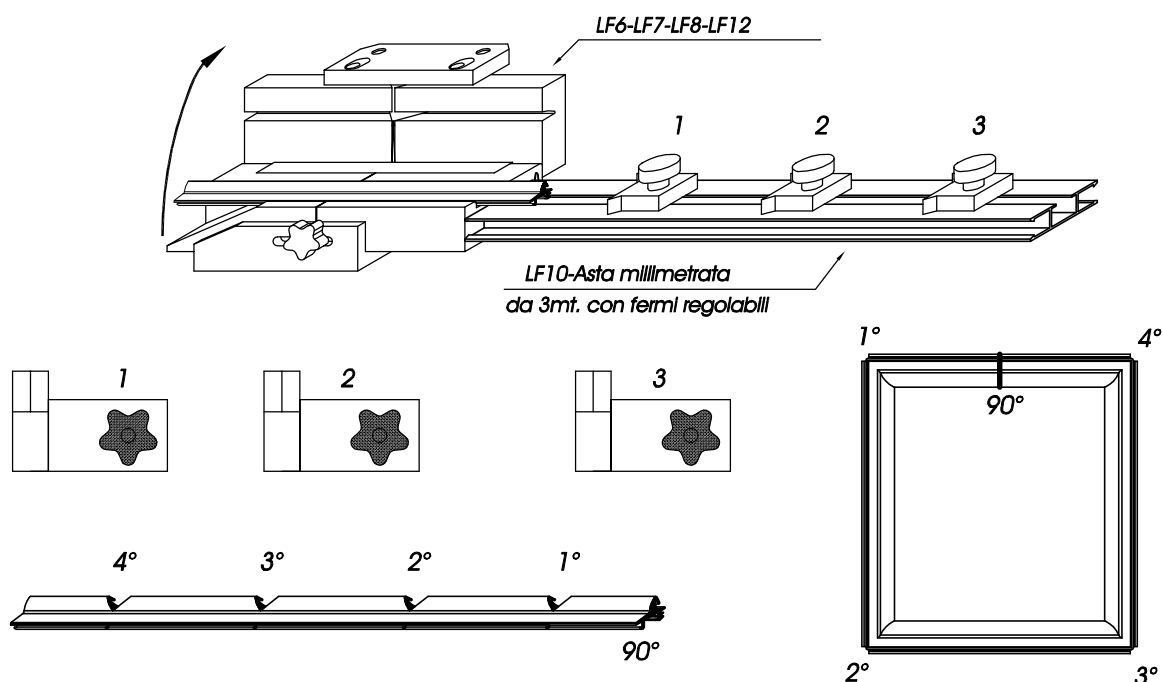

### FASI DI TAGLIO DELLA GUARNIZIONE

- *Tagliare la guarnizione a 90°, posizionarla sul fermo n°1 per fare il primo angolo (prima parte del traverso superiore).*
- *Spostare la guarnizione sul fermo n°2 per fare il secondo angolo (montante sinistro).*
- *Spostare la guarnizione sul fermo n°3 per fare il terzo angolo (traverso inferiore).*
- *Spostare la guarnizione sul fermo n°2 per fare il quarto angolo (montante destro).*
- *Spostare la guarnizione sul fermo n°1 e tagliare a 90° prendendo come riferimento la lama per fare la seconda parte del traverso superiore.*

*Attrezzatura per il taglio guarnizioni telaio  
Schere für Rahmendichtung  
Herramienta para cortar las juntas del marco  
Outillage pour la coupe du joint dormant  
Special equipment for the cut of the frame's gaskets*

## FORBICE PER GUARNIZIONE PROFILO ANTA

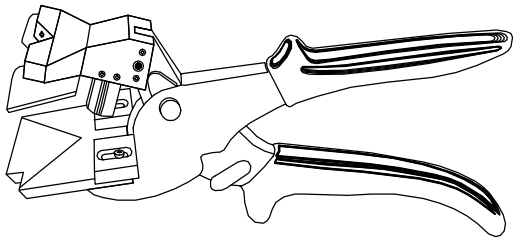

LF2

FORBICE PER GUARNIZIONE PROFILO ANTA

EPDM-ESPANSO

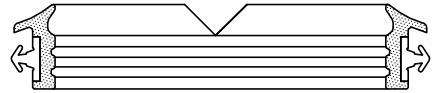

DE29

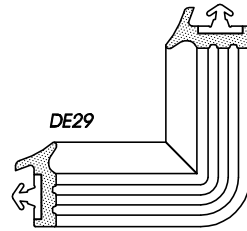

## NUOVA CIANFRINATRICE LACV98

*Cianfrinatrice verticale LACV-98*  
*Eckverbindungsstanze LACV-98*  
*Ensambladora vertical de ángulos LACV-98*  
*Sertisseuse verticale LACV-98*  
*Vertical beader LACV-98*

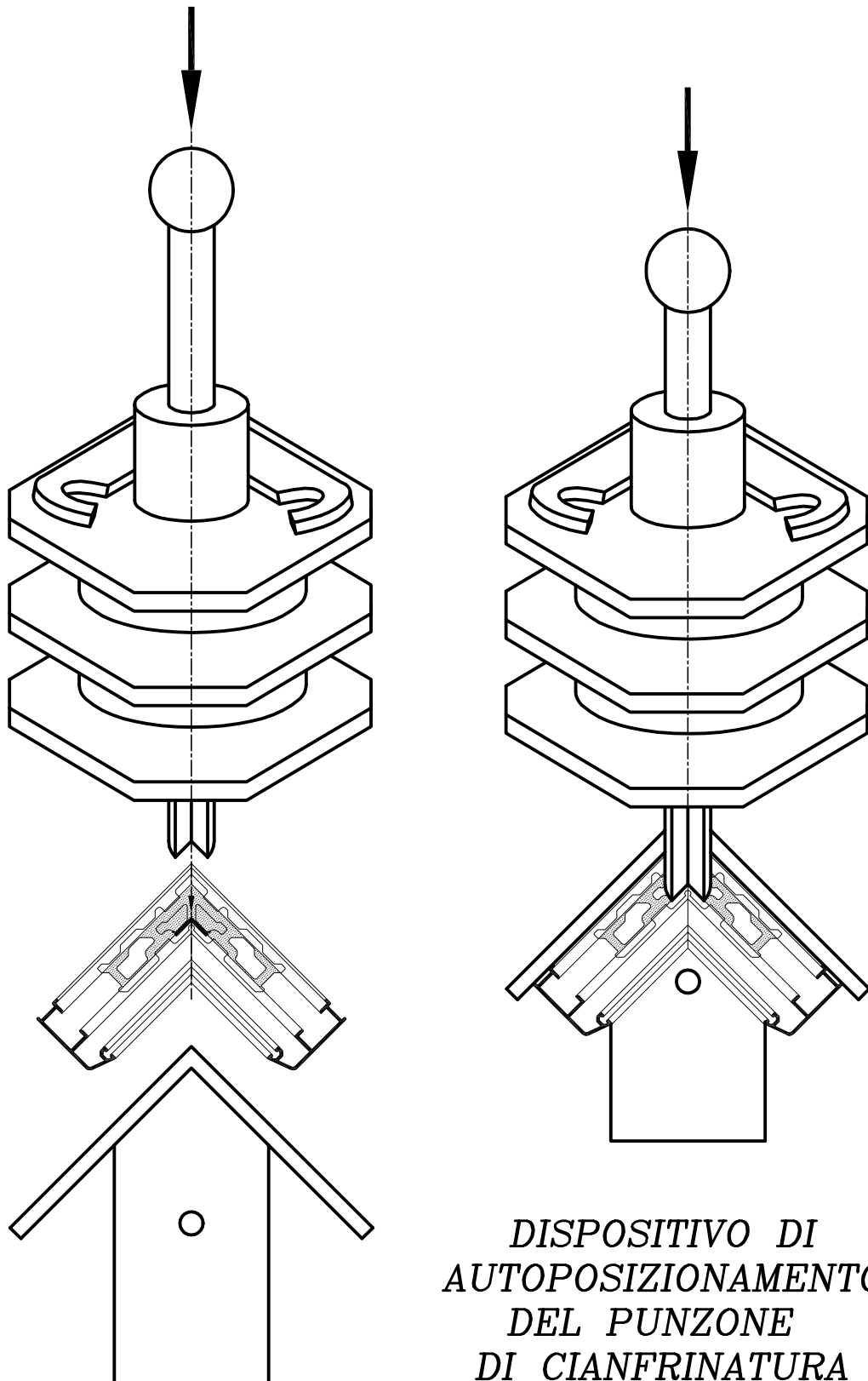

*Cianfrinatrice verticale LACV-98  
Eckverbindungsstanze LACV-98  
Ensambladora vertical de ángulos LACV-98  
Sertisseuse verticale LACV-98  
Vertical beader LACV-98*

**LACV-1**

PUNZONATRICE PNEUMATICA  
PER ASOLE DI SCARICO ACQUA

LC11

LC11B

TAPPI PER SCARICO ACQUA  
PER PROFILI TELAIO  
Colore: LC11-Nero  
LC11B- Bianco

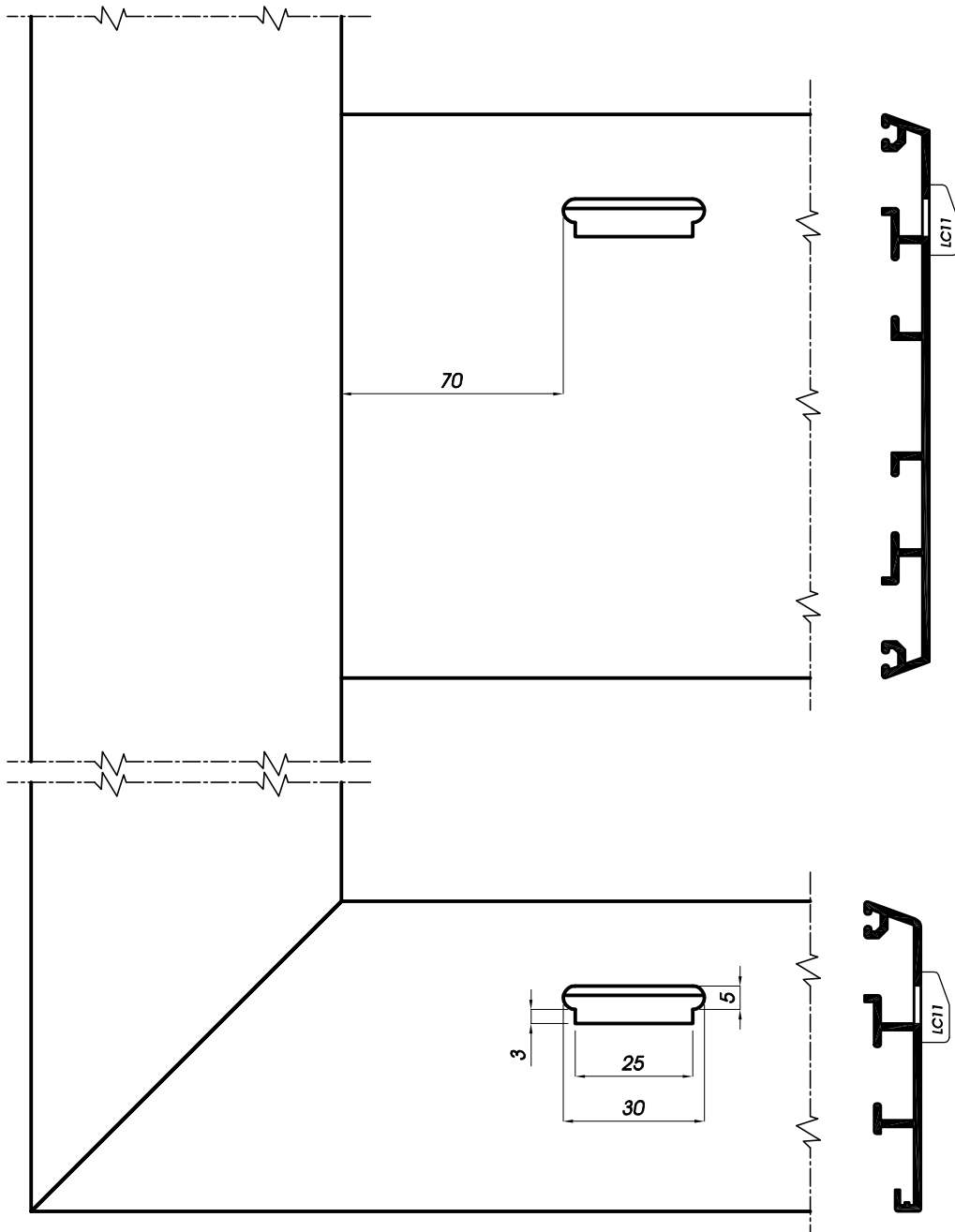
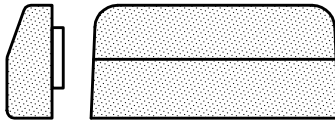

*Attrezzatura per esecuzione cave di scarico  
Pneumatische Stanze für Wasserabläufe  
Punzonadora neumática para agujeros de desagüe  
Outillage pour la réalisation des rainures d'evacuation de l'eau  
Special equipment for the performig of water-holes*

# CHIAVI E DIME PER IL MONTAGGIO

LD03

CHIAVE PER LC4



LD12

CHIAVE PER LC3



LD13

CHIAVE PER LC18 e LC27

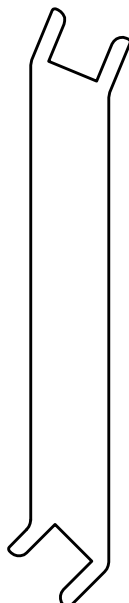

LD04

RULLINO

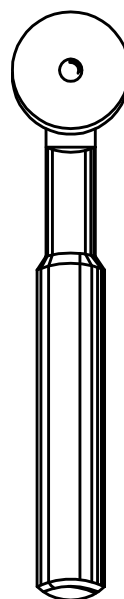

LD05B

DIMA

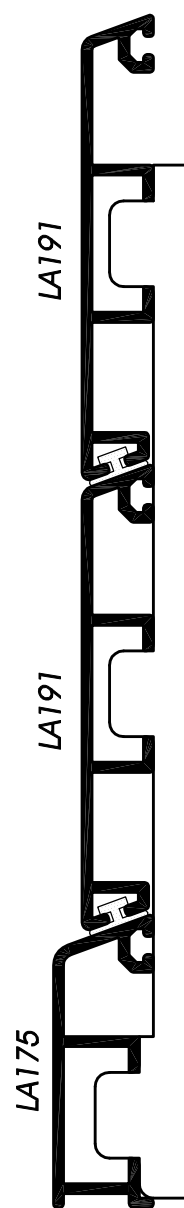

LD06

DIMA

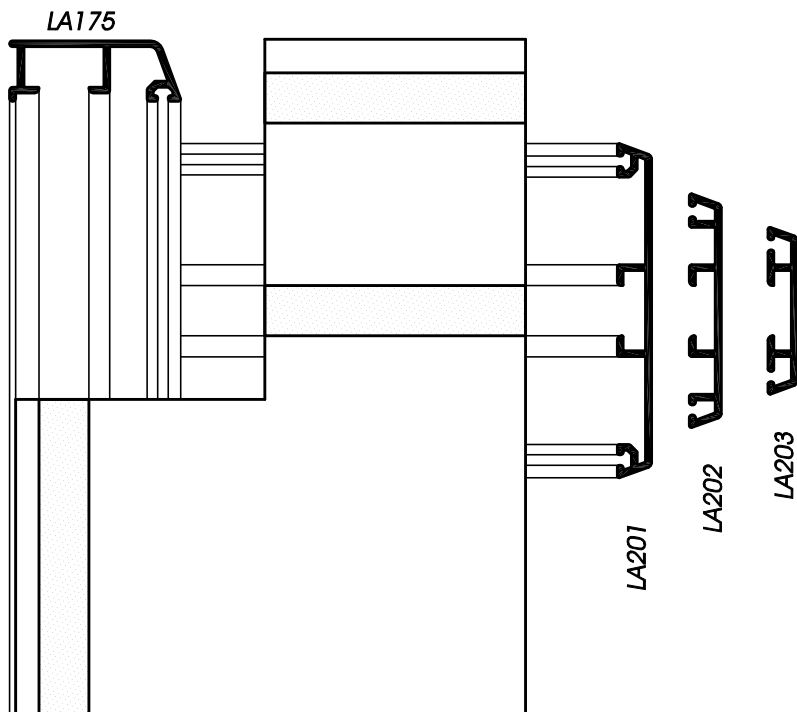

*Chiavi e attrezzature per il montaggio dei profili  
Montageschlüssel und Lehren für Profile  
Llave para clips y plantilla para el montaje de los perfiles  
Clefs et outillages pour l'assemblage des profils  
Special equipment for the assembly of the profiles*



# DIME PER POSIZIONAMENTO CLIPS

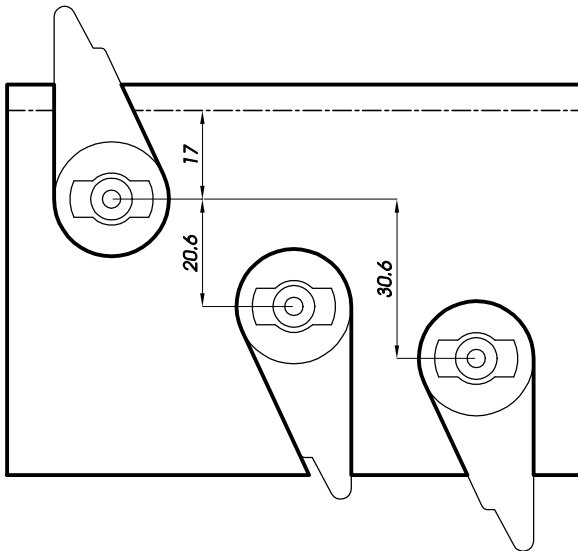

LD14

DIMA PER TELAIO  
ERMETIC 5000/S-5000/S LIGHT

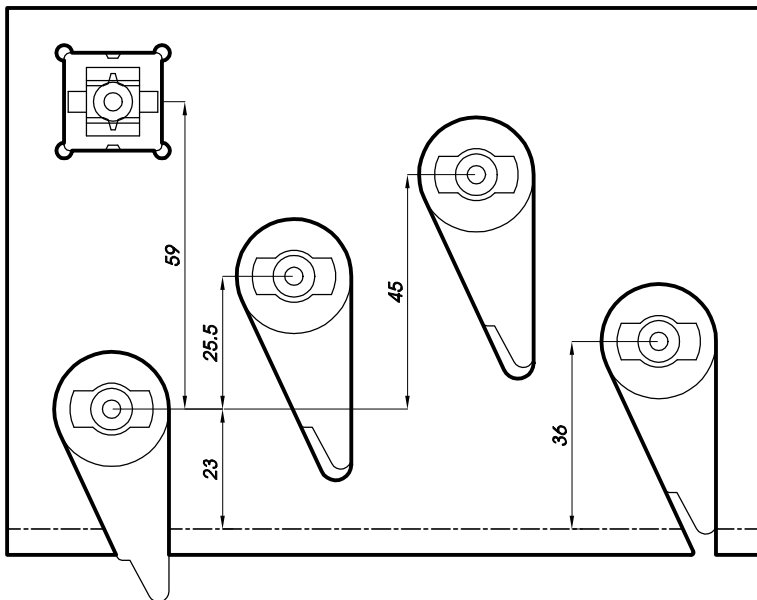

LD15

DIMA PER ANTA  
ERMETIC 5000/S-5000/S LIGHT

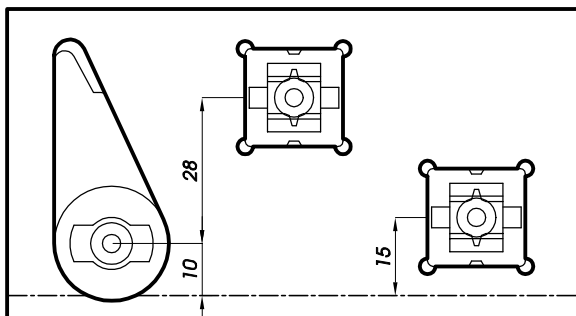

LD16

DIMA PER CHISURA CENTRALE  
ERMETIC 5000/S-5000/S LIGHT

Dime di posizionamento clips con viti  
Lehren für Drehalter mit Schrauben  
Plantillas para colocar las clips  
Gabarits pour le positionnement des clips avec vis  
Template of the clips with screw