

ENG
OX
RENTAL

ALWAYS IMPROVING
OUR SERVICES
AND EASING
YOUR DUTIES

ES
OX
RENTAL

SIEMPRE MEJORANDO
NUESTROS SERVICIOS
Y FACILITANDO
SUS TAREAS

OX RENTAL.

In OX Worldwide we offer a wide range of rental products.

Any operation that needs tools or elements not "usual" in your company, or being interesting for questions of management flexibility, not having capital immobilized, cost reduction... with these premises, we can help you with a wide range of products and very competitive prices.

OX ALQUILER.

En OX Worldwide ofrecemos una amplia gama de productos de alquiler.

Cualquier operación que necesite herramientas o elementos que no suelen utilizarse en su empresa, o ser interesante por cuestiones de flexibilidad de gestión, no tener capital inmovilizado, reducción de costes ... con estas premisas, podemos ayudarle con una amplia gama de productos a precios competitivos.



SELF-PROPELLED TROLLEYS
TANQUETAS AUTOPROPULSADAS



MANUAL TROLLEYS
TANQUETAS MANUALES



RECTANGULAR SPREADER BEAM
BALANCIN SEPARADOR RECTANGULAR



SPREADERS BEAM
BALANCINES SEPARADORES



ALUMINIUM PORTABLE GANTRIES
PÓRTICO ALUMINIO

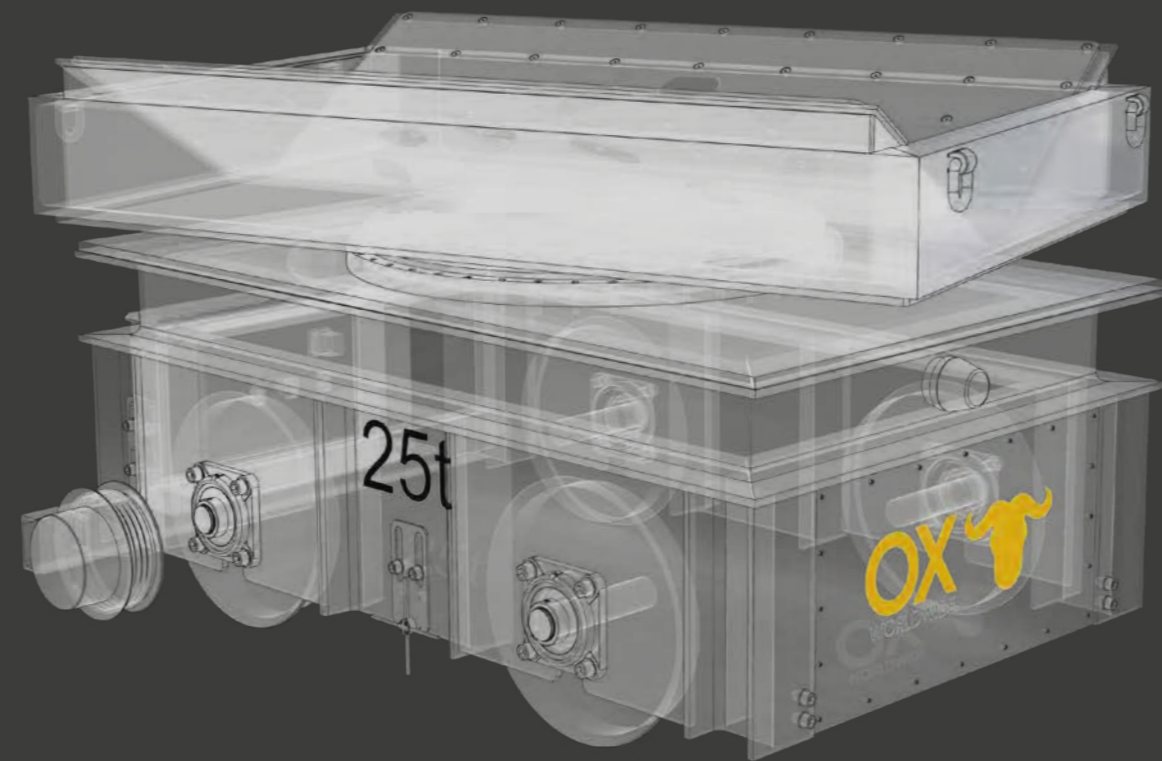

www.oxworldwide.com



OUR COMPANY
NUESTRA EMPRESA

HEAVY LIFTING EQUIPMENT

EQUIPAMIENTO PARA GRANDES CARGAS

OX
WORLDWIDE

GENERAL CATALOGUE
CATÁLOGO GENERAL

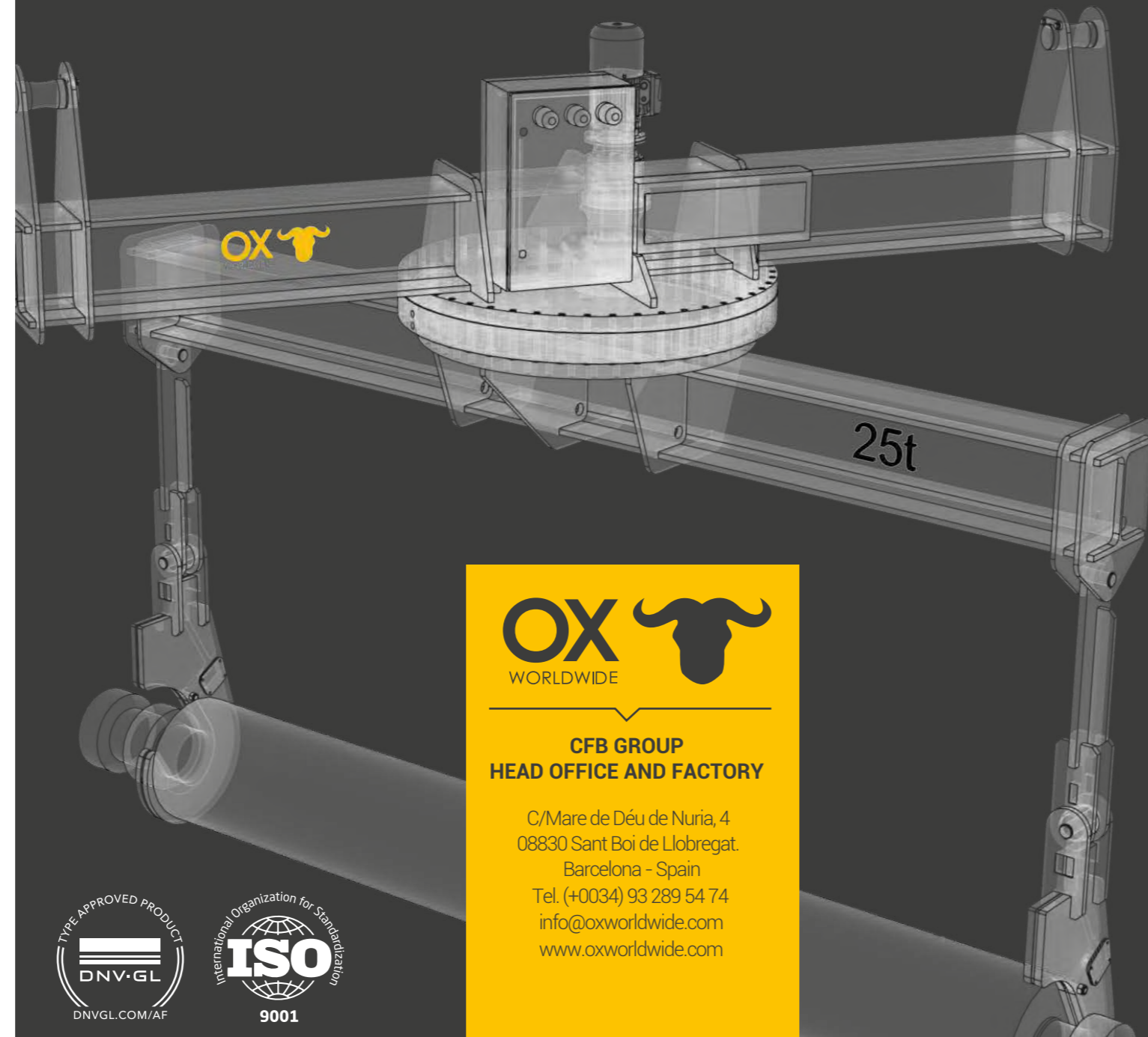

CFB GROUP
HEAD OFFICE AND FACTORY

C/Mare de Déu de Nuria, 4
08830 Sant Boi de Llobregat.
Barcelona - Spain
Tel. (+0034) 93 289 54 74
info@oxworldwide.com
www.oxworldwide.com



CFB - OX WORLDWIDE:

CFB - Ox Worldwide was founded in 1992 with the mission to provide professional solutions for the transport and lifting of loads in a safe and controlled way for the industry, navy, rail, wind energy, oil&gas, offshore, automotive, aeronautics and small industries.
We work anywhere in the world.

At CFB - Ox Worldwide, the engineering, the raw material and the advice are the bases of our quality.

ISO & DNV CERTIFICATES

We have managed to manufacture and distribute machinery that meets the highest standards. For this is requirements is madatory to pass all the quality controls, that's why we have the next certifications:

- ISO 9001:2015
- UNE EN ISO 3834-2:2006 (welding)
- DNV GL-ST-0378 (spreaders)
- DNV GL-ST-0377 (spreaders)

CFB - Ox Worldwide is guaranteed by regular certified inspections, certified and approved by Lloyd Register Quality Assurance.



"Our priority is to provide effective, profitable and safe solutions, to ensure long-term business relationships, through customer satisfaction"

Emilio Blasco, founder

CFB - OX WORLDWIDE

CFB - Ox Worldwide fue creada en 1992 con la misión de proporcionar soluciones profesionales para el transporte y elevación de cargas de manera segura y controlada en cualquier sector industrial, naval, ferroviario, eólico, oil&gas, offshore, automoción, aeronáutico y pequeñas industrias.
Trabajamos en cualquier lugar del mundo.

En CFB - Ox Worldwide, la ingeniería, la materia prima y el asesoramiento son la base de nuestra calidad.

CERTIFICADO ISO & DNV

Hemos conseguido fabricar y distribuir maquinaria que cumplen los más altos estándares. Para ello es requisito indispensable pasar todos los controles de calidad, por eso disponemos de las siguientes certificaciones:

- ISO 9001:2015
- UNE EN ISO 3834-2:2006 (soldadura)
- DNV GL-ST-0378 (Separadores)
- DNV GL-ST-0377 (Separadores)

CFB - Ox Worldwide está garantizada por inspecciones regulares certificados de aprobación por parte de Lloyd Register Quality Assurance.

OX

TANQUETAS

WLL / CMU (t):

400 200 150 100 60 30

We designs and build self-propelled trolleys from 30 to 400 tons to solve any needs on loads transport in the industrial area.

Diseñamos y fabricamos tanquetas autopropulsadas de 30 a 400 toneladas para resolver las necesidades para el movimiento de cargas en el sector industrial.

OX

BALANCINES SEPARADORES



Wide range of adjustable spreader beams, with interchangeable sections of any length under request or 500, 1000, 2000, 4000 mm standard.
WLL: From 9 to 1350 tons

Amplia gama de balancines separadores ajustables en longitud, con piezas interiores intercambiables de cualquier longitud bajo demanda o standard de 500, 1000, 2000, 4000 mm.
CMU: De 9 tons hasta 1350 tons.



OX

BALANCINES DE ELEVACION

ECOBEAM is an economical beam with fast delivery. Ox Worldwide has semi-manufactured pieces on Stock, being able to deliver quickly any order, for a range of capacities between 1 to 10t and length between 1000 to 4000 mm, both in the STANDARD and ADJUSTABLE types.



El ECOBEAM es un balancín económico y de rápido suministro, ya que Ox Worldwide dispone en stock de semielaborados, con los cuales es rápido realizar cualquier suministro, para un rango de capacidades de 1 a 10t y longitudes de 1000 a 4000 mmm, tanto en versión ESTANDAR (fijo) como en la AJUSTABLE (regulable).

OX

WORLDWIDE



WE MANUFACTURE ANY KIND OF EQUIPMENT FOR TRANSPORT OF LOADS

FABRICAMOS TODO TIPO DE MAQUINARIA PARA EL TRANSPORTE DE CARGAS

ALL INDUSTRIAL SECTORS



HYDRAULIC JACKS
GATOS HIDRÁULICOS

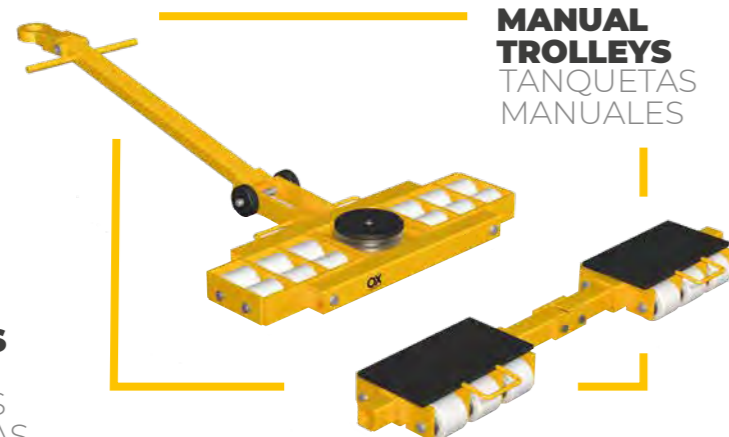

MANUAL TROLLEYS
TANQUETAS MANUALES



LIFTING BEAMS
BALANCINES DE ELEVACION



ROTATING BEAMS
BALANCINES GIRATORIOS



MOTORIZED PAPER ROLL CLAMPS
PINZA BOBINA MOTORIZADA



LOAD ROTATOR
GIRAPIEZAS



J HOOKS
GANCHOS J



SPREADERS BEAM
BALANCINES SEPARADORES

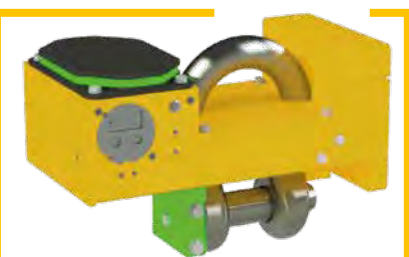

AUTOMATIC SHACKLES
GRILLETES AUTOMÁTICOS



RECTANGULAR SPREADER BEAM
BALANCIN SEPARADOR RECTANGULAR

MOTORIZED TROLLEYS COIL CARS
CARROS MOTORIZADOS
CARROS PORTA BOBINAS



H TYPE BEAMS
BALANCINES H



SPECIAL BEAMS
BALANCINES ESPECIALES



CHAIN ROTATORS
GIRAPIEZAS
POLEA CADENA



C TYPE HOOKS
GANCHOS C



COIL TILTERS
VOLTEADORES

www.oxworldwide.com

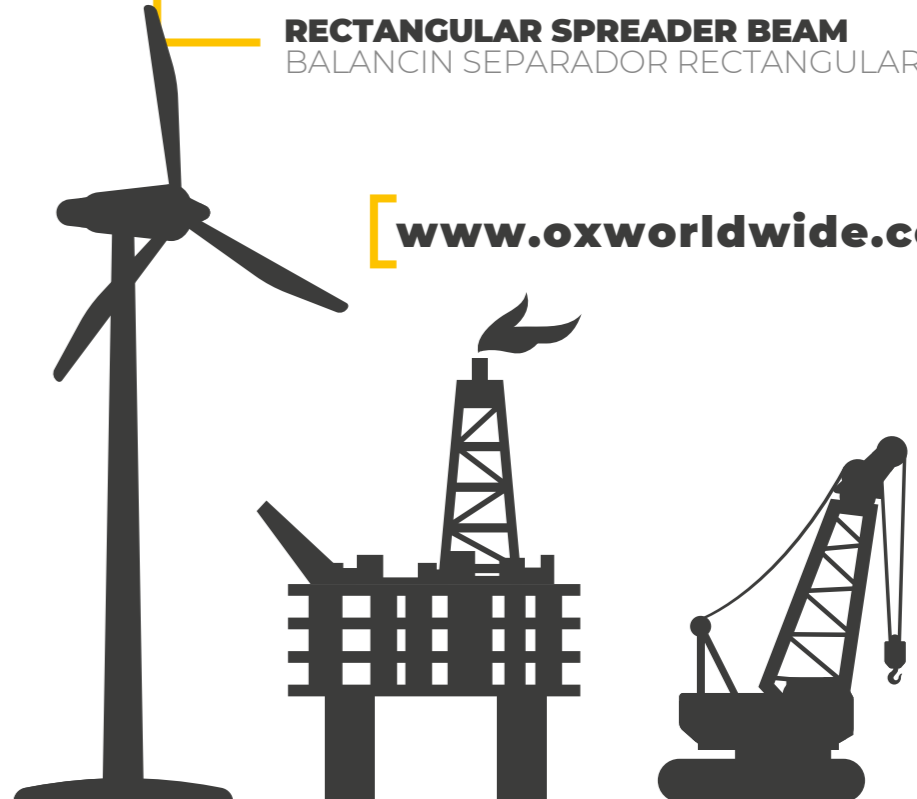

WIND ENERGY
OIL&GAS
OFFSHORE
NAVAL
SHIPYARDS
CRANES
AERONAUTICS
NUCLEAR
RAILWAY
PROJECT CARGO
STEEL
LOGISTICS