

# Automatic parking. Parking system auto- UP

# Data sheet

## Parking system auto-UP

Universal parking system for parking up to 100 vehicles with 1 Storage and retrieval unit in a max. height of 20 m, as an underground, above ground or mixed solution.

The parking system auto-UP is the universal parking system, that enables you to build more parking places more economically in office buildings, hotels, residential buildings or public parking systems. About 100 parking places for various vehicle heights can be handled by only 1 storage and retrieval unit in a max. height of 20 m. The rack structure can be built above ground, underground or in a mixed solution.

The parking places can be located either in a **free standing** steel rack structure or in a **concrete** structure with intermediate slabs. A pallet quick change solution enables short cycle times, even in a double row arrangement with 2 vehicles behind each other. The vehicles can be parked and retrieved in driving direction.

### Free standing rack structure above ground

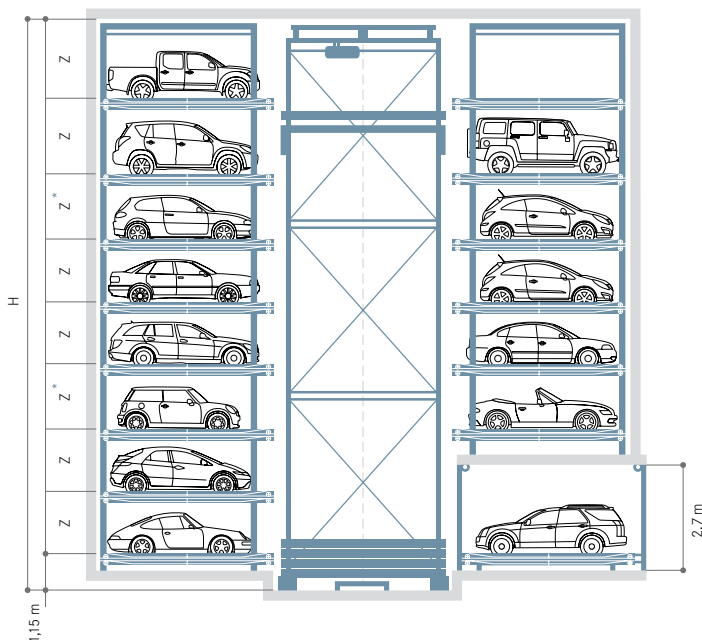

### Parking places in a concrete structure, under ground

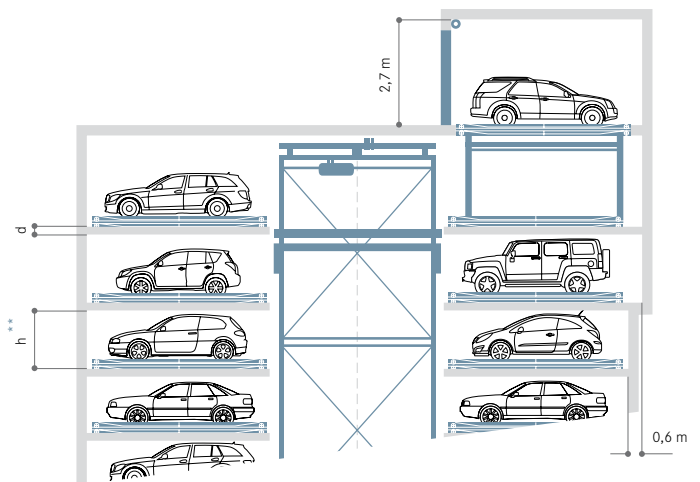

Using the option of a lateral car lift allows for transfer room location above the parking system.

\*\* Clear level height  $h = \text{vehicle height} + 0,34 \text{ m}$

The location of the transfer room can be defined on any level within the parking levels.

\*  $Z = \text{Vehicle height} + 0,28 \text{ m}$ . For structural reasons every third parking level must be increased by 0,1 m.

Dimension Z is depending on the vehicle height:  
for vehicle height = 1,60 m,  $z = 1,88 \text{ m}$   
for vehicle height = 2,00 m,  $z = 2,28 \text{ m}$

The auto-UP parking system allows for various vehicle heights.



#### Transfer room

Vehicles will be parked head-in inside the transfer room and checked for correct position. The vehicle will then be parked via the turntable or directly via the storage and retrieval unit onto an empty shelf. To exit, the vehicle will be returned to the driver head-out. At no time is the driver ever allowed to interact with the automated mechanism.

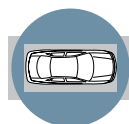

#### Turntable

Once the vehicle is parked inside the transfer room, the position checked and passengers having exited, the vehicle will be rotated to a head-out position and parked automatically. The turntable allows for any angle position for entry and exit.

## Transfer room: feasible solutions for transfer room arrangement

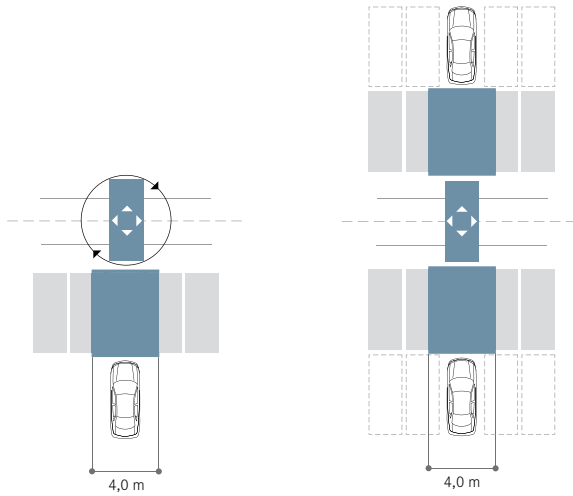

The vehicle drives into the transfer room, then will be turned on the SRU and parked in an empty shelf. It will be retrieved for exit in driving direction.

This solution shows a separated entrance and exit room without turntables.

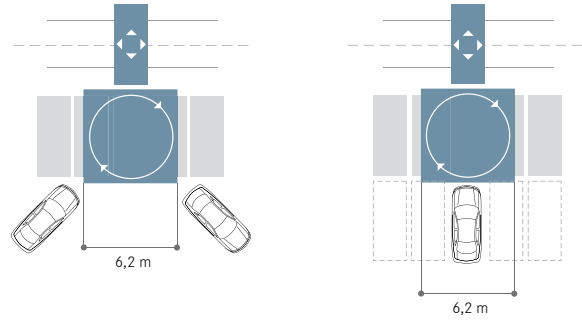

The entrance and exit angle can be adapted to the local requirements.

In this solution shows a turntable inside the transfer room.

## General informations

- Both solutions allow for double row or mixed row arrangement of the pallets.
  - The dimensions 5,20 m x 2,20 m of the parking platform are valid for both models and allow for vehicle dimensions of Length max = 5,10 m / width max. = 2,10 m.
- All measures given refer to these dimensions.

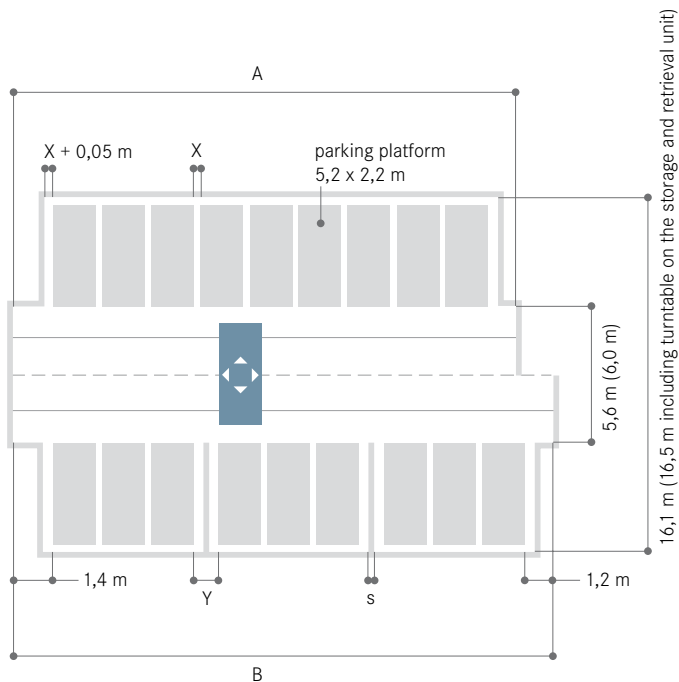

In a free standing rack structure the pallet distance  $x$  or  $Y$  are depending on the system height:

$X$  without wallplates /  $Y$  with wallplates  $s = 0,3$  m  
 for 2 to 4 levels:  $X = 0,18$  m /  $Y = 0,74$  m  
 for 5 and 6 levels:  $X = 0,2$  m /  $Y = 0,78$  m  
 for 7 and 8 levels:  $X = 0,22$  m /  $Y = 0,82$  m

Dimension for free standing solutions with cladding and more parking levels on request.

In a concrete structure with intermediate slabs the pallet distance  $X = 0,12$  m without wallplates. The distance  $Y$  including wallplates = wallplate dimension + 0,3 m.

For the installation of the cabinets there must be room with a length of 3,5 m and a width of 1,80 m and a clear height of 2,5 m. This room shall be located close to the transfer room.

## Exemplary calculation of system length and height

### Parking places in a steel rack structure

total length for 5 parking levels and 9 rows of pallets:  
 $A = 9 \times 2,2 + 8 \times 0,2 + 1,4 + 1,2 = 24,00$  m

### Parking places on intermediate concrete slabs

Total length for 9 rows of pallets including 2 wallplates of  $s = 0,3$  m (independent from number of parking levels):  
 $B = 9 \times 2,2 + 6 \times 0,12 + 2 \times 0,6 + 1,4 + 1,2 = 24,32$  m

Clear overall height for 3 parking levels for vehicles up to 1,60 m and 2 parking levels for vehicle height up to 2.00 m:

Steel rack structure:

$H = 1,15 + 3 \times 1,88 + 0,1 + 2 \times 2,28 = 11,45$  m

Intermediate concrete slabs  $d = 0,2$  m:

$H = 1,15 + 4 \times 0,2 + 3 \times 1,94 + 2 \times 2,34 = 12,45$  m



## Storage and retrieval unit (SRU)

The automatic storage and retrieval unit moves on vertical and horizontal lines to service the various units of the racks. This system allows for the doubling of available parking compared to conventional garage operations.

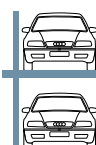

## Rack structure

The system can be constructed around a free standing or in-house steel rack framework. The vehicles are delivered onto parking pallets situated on a rack. As an alternative a concrete rack structure can be used with pallet's rails bolted to the intermediate slabs.



C/ Sebastián Elcano 32, 1º of. 21  
28012 - Madrid  
T 918.276.449  
F 917.903.583  
M 671.072.650  
info@park-in.es



Stolzer Parkhaus GmbH & Co. KG  
Industriestraße 12  
D-77855 Achern-Gamshurst  
T +49.(0)7841.704-0  
F +49.(0)7841.704-190  
info@stolzer.com  
www.stolzer.com