



CATÁLOGO 2006

presentación
presentation
présentation
presentazione



MEDID, fundada en 1932, viene dedicando su labor productiva a los distintos campos de la medición lineal, siendo especialmente pionera en la producción de flexómetros y cintas métricas en España.

En nuestras instalaciones fabriles, MEDID sigue en vanguardia del sector cuidando de aportar permanentemente a sus procesos de producción las más innovadoras tecnologías y destinando un esfuerzo importante a I+D.

Fruto de todo ello es este catálogo con el que pretendemos dar respuesta a cualquier necesidad de medición lineal en el mercado mundial, y del que esperamos se convierta para Vd. en su mejor colaborador profesional.



MEDID was established in 1932. Since it began it has worked primarily in the field of linear measurement, having been a pioneer in the introduction and manufacturing of measuring tapes in Spain. Our manufacturing process has also developed along with the technological changes which have taken place during recent years, and now operates in modern factories. We employ our own technology in its applications to exclusive manufacturing systems, including automated production. MEDID'S quality is assured by exhaustive controls which test the products for general quality and especially for metrological accuracy.

MEDID exports its products to the five continents, and bases its business on the quality and competitiveness of the products which it manufactures. Quality is the foundation of MEDID's working philosophy. For this reason, our products are guaranteed throughout the world.

MEDID a été fondée en 1932 et s'est spécialisée dès le départ dans le domaine de la mesure linéaire; elle a été pionnière dans la fabrication et l'introduction des mètres à ruban en Espagne.

Nos méthodes de fabrication ont également évolué parallèlement aux changements technologiques expérimentés tout au long des années et nous disposons actuellement de modernes installations, ainsi que de notre propre technologie appliquée à des systèmes de fabrication exclusifs, comportant des productions robotisées.

MEDID exporte ses produits vers les cinq continents grâce à la qualité et à la compétitivité des produits de sa fabrication. En effet, chez MEDID, la qualité est la base de l'esprit de travail et nous permet de garantir nos produits dans le monde entier.

MEDID, fondata nel 1932, si è dedicata sin dall'inizio alla fabbricazione di strumenti di misura lineari ed è stata la prima a sviluppare ed introdurre in Spagna il flessometro.

Anche il nostro processo di fabbricazione si è evoluto in base ai cambiamenti tecnologici avvenuti negli ultimi anni ed attualmente disponiamo sia di moderne attrezzature nella nostra fabbrica sia di una nostra tecnologia applicata a sistemi di fabbricazione esclusivi che comprendono anche produzioni automatizzate.

MEDID esporta i propri prodotti nei cinque continenti grazie alla loro qualità e concorrenzialità: la qualità infatti è l'obiettivo principale della fabbricazione della MEDID che le permette di garantire i propri prodotti in tutto il mondo.



3



20



27



44



55



62



70



81

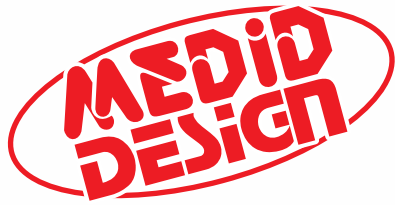

El diseño, unido a la tecnología y la capacidad de generar nuevos productos es lo que distingue a una marca de las demás.

Por eso, en MEDID PRECISIÓN, S.A., apostamos desde siempre por la innovación y renovación. En este empeño, nuestro equipo de diseñadores y técnicos está permanentemente investigando y desarrollando nuevas soluciones a los desafíos de siempre.

Soluciones técnicas y ergonómicas pero también ¿por qué no? estéticas.

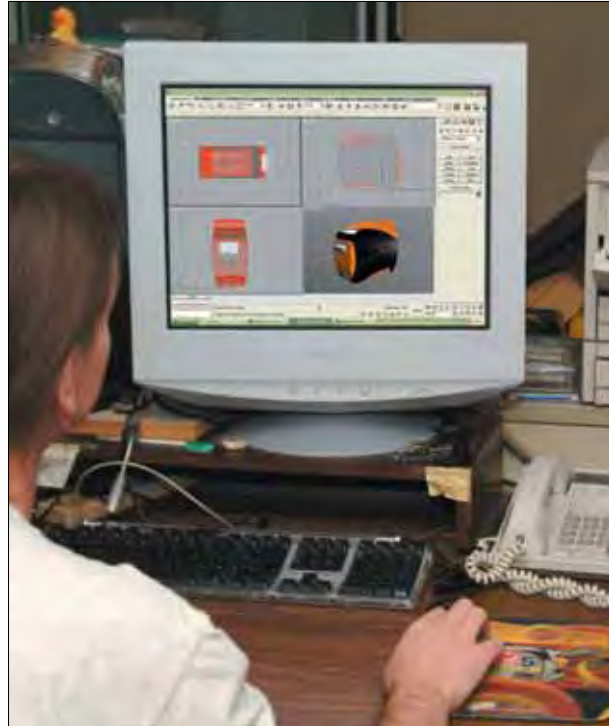
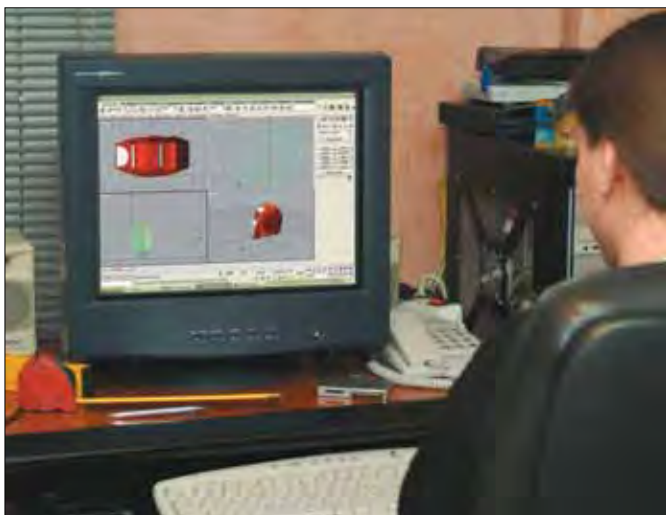

The design, together with the technology and the capacity to generate new products is what distinguishes a mark of the others.

For that reason, in MEDID PRECISIÓN, S.A., we always bet for the innovation and renovation. In this persistence, our team of designers and technicians are permanently investigating and developing new solutions to the challenges of always.

Technical and ergonomic solutions but also, why not?, aesthetic.

La conception, unie à la technologie et à la capacité de produire de nouveaux produits est ce qui distingue une marque des autres.

C'est pourquoi, a MEDID PRÉCISIÓN, S.A, nous parions depuis toujours sur l'innovation et la rénovation. Dans cette persistance, notre équipe de dessinateurs et techniciens de façon permanente fait des recherches et en développant de nouvelles solutions aux défis de toujours.

Solutions techniques et ergonomiques mais aussi pourquoi pas? esthétiques.

Il design, unito alla tecnologia ed alla capacità di generare nuovi prodotti è quello che distingue una azienda dalle altre.

Per questo in MEDID PRECISIÓN S.A. lavoriamo sempre volti alle innovazioni ed al rinnovo. In questo impegno i nostri team di disegnatori e tecnici sono permanentemente allo studio di nuove soluzioni per le sfide di mercato.

Soluzioni tecniche, ergonomiche, e perché no? esteticamente piacevoli.



Diseño Medid

Medid design

Dessin Medid

Design Medid





Todos los flexómetros y cintas métricas MEDID corresponden a modelos homologados cuya calidad satisface los controles y requerimientos CEE.

All our measuring tapes correspond to homologated models whose quality satisfies the controls and requirements EEC.

Tous les rubans MEDID correspondent à des modèles homologués, dont la qualité satisfait tous les contrôles et normes de la CEE.

Tutti i nostri flessometri e metri corrispondono a modelli emologati a norma del controlli e requisiti CEE.



LONGITUD
LENGTH
LONGUEUR
LUNGHEZZA

Nº IDENTIFICACIÓN
IDENTIFICATION NUMBER
Nº IDENTIFICATION
Nº D'IDENTIFICAZIONE

CLASE PRECISIÓN
ACCURACY CLASS
CLASSE PRECISION
CLASSE DI PRECISIONE

PAIS Y AÑO
YEAR & COUNTRY
PAYS ET ANNÉE
PAESE E ANNO
Nº APROBACIÓN
PATTERN APPROVAL
Nº APPROBATION
Nº APPROVAZIONE



CUADRO DE TOLERANCIAS
TOLERANCE TABLE
TABLEAU DE TOLÉRANCES
TABELLA DI TOLLERANZA

PRECISIÓN ACCURACY PRECISION PRECISIONE	LONG./TOLERANCIA LENGHT/TOLERANCE LONG./TOLERANCE LUNG./TOLLERANZA (± mm)									
	1 m	2 m	3 m	5 m	8 m	10 m	20 m	30 m	50 m	100 m
Clase I = 0,1+0,1L	0,2	0,3	0,4	0,6	0,9	1,1	2,1	3,1	5,1	10,1
Clase II = 0,3+0,2L	0,5	0,7	0,9	1,3	1,9	2,3	4,3	6,3	10,3	20,3
Clase III = 0,6+0,4L	1,0	1,4	1,8	2,6	3,8	4,6	8,6	12,6	20,6	40,6

L = Longitud / Length / Longueur / Lunghezza

La uña deslizable de los flexómetros garantiza el punto "0" tanto en mediciones exteriores como interiores.

The sliding hook guarantee you always the "true zero" inside or outside measurements.

Le crochet coulissant garantie toujours le vrai point zero.

Il calciolo mobile garantisce che il punto "0" sia sempre centrato, posto all'interno che all'esterno.

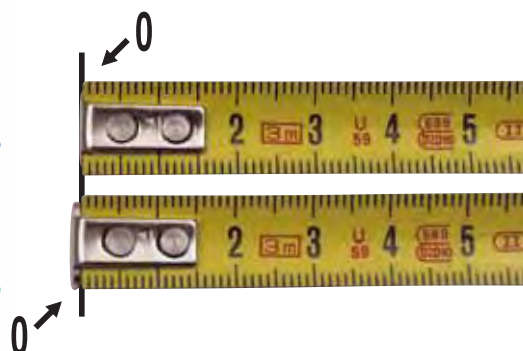



cinta impresa en ambas caras

tape printed on both sides
ruban graduée sur les 2 faces
nastro stampato sui due lati



REVERSO: escala vertical.
BACK: vertical scale.
REVERS: verticale.
RETRO: scala verticale.

ANVERSO: escala horizontal.
FRONT: horizontal scale.
ENVERS: horizontale.
FRONTE: scala orizzontale.



uña blindada / reinforced hook / crochet blindé / calciolo blindato

MÁS RESISTENCIA = MAYOR DURACIÓN = MÁS PRECISIÓN.

MORE RESISTANCE = LONGLASTING = MORE ACCURACY.

PLUS RESISTANT = DUREE DE VIE AMELIOREE = PLUS PRECISION.

PIÙ RESISTENZA = MAGGIOR DURATA = PIÙ PRECISIONE.

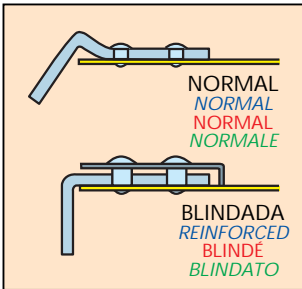

NORMAL
NORMAL
NORMAL
NORMALE

BLINDADA
REINFORCED
BLINDÉ
BLINDATO

MAYOR SUAVIDAD DE DESPLAZAMIENTO.
REMACHES DE MAYOR GROSOR.

SLIPPERY SLIDING.
BIGGER RIVETS.

CROCHET PLUS GLISSANT.
RIVETS PLUS LARGES.

CALCIOLO PIÙ SCORREVOLE.
RIVETTI PIÙ LARGHI.

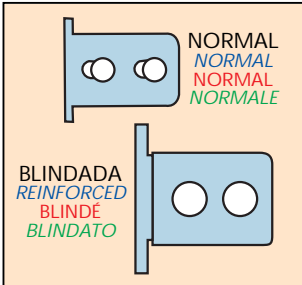

NORMAL
NORMAL
NORMAL
NORMALE

BLINDADA
REINFORCED
BLINDÉ
BLINDATO

MÁS EXACTITUD EN LAS MEDICIONES
POR EL MEJOR GUIADO DE LA UÑA.

GRANTED ACCURACY DUE TO THE BETTER
GUIDANCE OF THE HOOK.

PLUS PRECISION POUR LA MEILLEURE
GUIDE DE L'AGRAFE.

PIÙ PRECISIONE PER LA MIGLIOR GUIDA
DEL CALCIOLO.

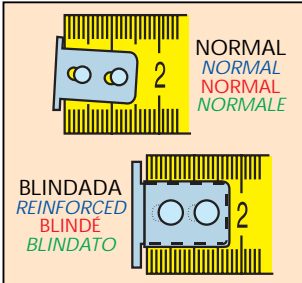

NORMAL
NORMAL
NORMAL
NORMALE

BLINDADA
REINFORCED
BLINDÉ
BLINDATO

MEJOR AGARRE POR SU MAYOR
ANCHURA.

BETTER HOLDING THANKS TO THE
ENLARGED WIDENESS.

MEILLEUR TENU DU' A LA NOUVELLE
LARGEUR.

MIGLIOR TENUTA PER LA SUA MAGGIOR
LARGHEZZA.

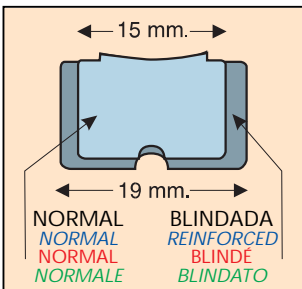

15 mm.

19 mm.

NORMAL
NORMAL
NORMAL
NORMALE

BLINDADA
REINFORCED
BLINDÉ
BLINDATO

uña antideslizante / non-skid hook / crochet antidérapant / calciolo antiscivolo

Uña con superficie de goma
de gran agarre.

Hook with rubber surface
of great hold.

Crochet avec surface de gomme
de grande prise.

Calciolo con superficie di
gomma antiscivolo.

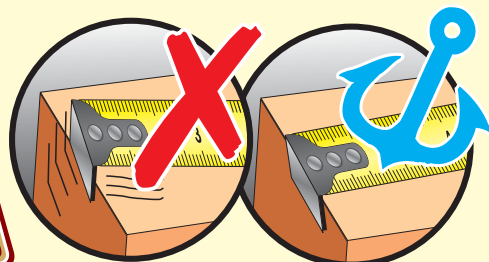

Cinta impresa en ambas
caras, uña blindada y uña
antideslizante

Tape printed on both
sides, reinforced hook
and non-skid hook

Ruban graduée sur les 2
faces, crochet blindé et
crochet antidérapant

Nastro stampato sui due
lati, calciolo blindato e
calciolo antiscivolo





Las cintas UPS[®], desarrolladas mediante tecnología y procesos exclusivos de MEDID, duran 10 veces más que las cintas normales (*)

(*) TEST JIS: UPS[®] resiste más de 500 ciclos, frente a los 240 ciclos del competidor más cercano, y los entre 15 y 70 ciclos de resistencia de la mayoría de marcas de todo el mundo.

UPS[®] tape, produced with machinery engineering entirely developed and patented by MEDID, it's 10 times more resistant than normal ones ()*

(*) TEST JIS: UPS[®]-MEDID tapes resist 500 cycles against the 240 of the best placed concurrent, and the 15 to 70 of the majority of brands.

Les rubans UPS[®], développés et brevetés par MEDID, sont 10 fois plus résistants que les rubans normaux (*)

(*) TEST JIS: UPS[®] résiste 500 cycles, contre les 240 du concurrent le mieux placé, et les 15 à 70 cycles de la majorité des autres rubans.

I nastri UPS[®], sviluppati e brevettati da MEDID, durano circa 10 volte più del normale ()*

(*) TEST JIS: UPS[®] resiste più di 500 cicli, rispetto ai 240 cicli dei concorrenti più venduti, e 15 o 70 cicli di resistenza di fronte alla maggioranza delle marche di tutto il mondo.

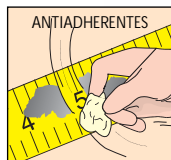

ANTIADHERENT
ANTI-ADHERENT
ANTIADHERENTE

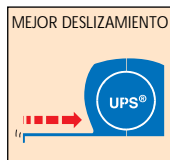

SLIPPERY COATING
REVETEMENT LISSE
RITORNO MORBIDO



LONG LIFE
MEILLEURE DUREE DE VIE
PIU DURATURU



NON-REFLECTIVE
ANTI-REFLECHISSANT
ANTIRIFLESSO

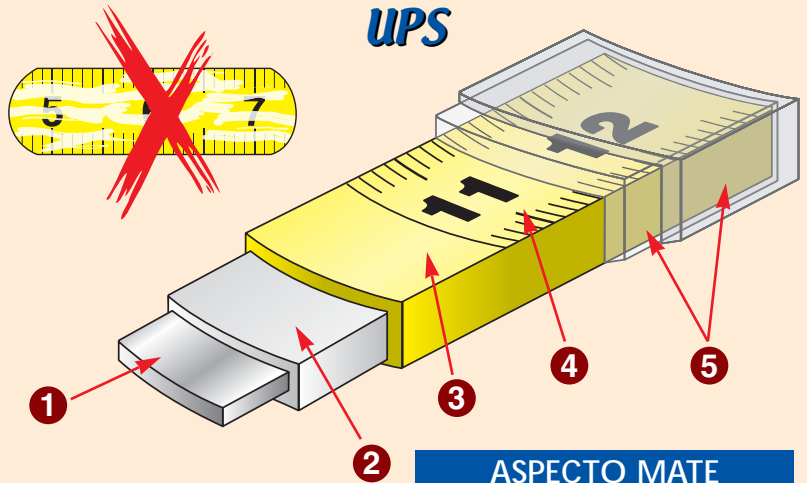

ASPECTO MATE
SATIN CHROME FINISHING
FINISSAGE MAT
ASPETTO OPACO

- 1: Base de acero extrafino templado.
- 2: Tratamiento de anclaje.
- 3: Esmalte opaco, polimerizado a alta temperatura.
- 4: Estampación de la graduación y numeración.
- 5: Esmalte transparente bicapa, mediante deposición por tecnología UPS[®].

- 1: Tempered steel base.
- 2: Surface anchoring treatment.
- 3: Opaque enamel, polymerized at high temperature.
- 4: Printing of graduation and numbering.
- 5: Two coatings transparent enamel (UPS[®] technology deposition).

- 1: Base en acier extrafin trempé.
- 2: Traitement d'ancrage.
- 3: Email opaque, polymérisé à température élevée.
- 4: Impression de la graduation et de la numération.
- 5: Email transparent bicouche, déposé par technologie UPS[®].

- 1: Base di acciaio temperato.
- 2: Trattamento di ancoraggio.
- 3: Smalto opaco, polimerizzato ad alta temperatura.
- 4: Incisione della graduazione e numerazione.
- 5: Smalto trasparente con doppio strato, mediante deposizione con tecnologia UPS[®].

UPS + Nylon Coated

- A: Esmalte transparente bicapa UPS.
B: Recubrimiento de Nylon.

- A: Two coatings transparent enamel UPS.
B: Nylon coating.

- A: Email transparent bicouche UPS.
A: Revêtement en Nylon.

- A: Smalto trasparente doppio strato UPS.
B: Con Nylon.

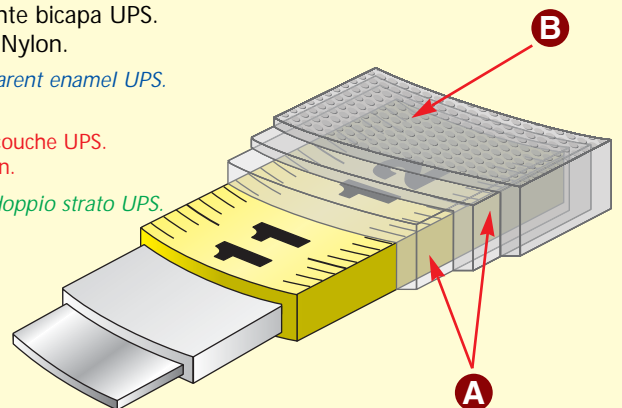

Tecnología UPS +
Nylon Coated

Technology UPS +
Nylon Coated

Techologie UPS +
Nylon Coated

Tecnologia UPS +
Nylon Coated





UPS + Nylon Coated

PROTECTOR

NEW

Ref.	m						€
43191	3	19 mm	Inox+Elastollan	●	10	8421411015247	
45191	5	19 mm	Inox+Elastollan	●	5	8421411015254	
45251	5	25 mm	Inox+Elastollan	●	5	8421411015261	
48251	8	25 mm	Inox+Elastollan	●	5	8421411015278	



clase I



Estuche muy robusto de acero inoxidable y elastollan, grabado con láser.

Very robust stainless steel plus elastollan case, engraving with laser.

Boîter très robuste acier inoxydable et élastomère, gravé avec laser.

Carcassa rinforzata in acciaio inossidabile e elastomero, impressa a laser.

Pausa inferior muy cómoda

Very comfortable inferior pause

Freiu inférieur très comode.

Doppio freno molto comodo.

PRECISION ACCURACY PRECISION PRECISIONE	LONG./TOLERANCIA LENGHT/TOLERANCE LONG./TOLERANCE LUNG/TOLLERANZA (± mm)										
	1 m	2 m	3 m	5 m	8 m	10 m	20 m	30 m	50 m	100 m	
Clase I = 0,1+0,1L	0,2	0,3	0,4	0,6	0,9	1,1	2,1	3,1	5,1	10,1	



Flexómetros UPS + Nylon Coated Clase I y Clase II

UPS measuring tapes + Nylon Coated Class I and Class II

Mètres à ruban UPS + Nylon Coated Classe I et Classe II

Flessometri UPS + Nylon Coated Classe I e Classe II

UPS + Nylon Coated

NEW

Ref.	m						€
43190	3	19 mm	Inox+Elastollan	●	10	8421411015209	
45190	5	19 mm	Inox+Elastollan	●	5	8421411015216	
45250	5	25 mm	Inox+Elastollan	●	5	8421411015223	
48250	8	25 mm	Inox+Elastollan	●	5	8421411015230	
43190	3	19 mm	Inox+Elastollan	--	36	8421411015759	
45190	5	19 mm	Inox+Elastollan	--	36	8421411015766	
45250	5	25 mm	Inox+Elastollan	--	36	8421411015773	
48250	8	25 mm	Inox+Elastollan	--	18	8421411015780	



clase II



Estuche muy robusto de acero inoxidable y elastollan, grabado con láser.

Very robust stainless steel plus elastollan case, engraving with laser.

Boîter très robuste acier inoxydable et élastomère, gravé avec laser.

Carcassa rinforzata in acciaio inossidabile e elastomero, impressa a laser.

Pausa inferior muy cómoda

Very comfortable inferior pause

Freiu inférieur très comode.

Doppio freno molto comodo.



**Flexómetros
inoxidables
+ Nylon Coated**

**inox
measuring tapes
+ Nylon Coated**

**Mètres à ruban
inox
+ Nylon Coated**

**Flessometri
inossidabili
+ Nylon Coated**



Ref.	m							€
25473	3	19 mm	Cromado Mate	●	10	8421411010044		
25474	5	19 mm	Cromado Mate	●	5	8421411010679		

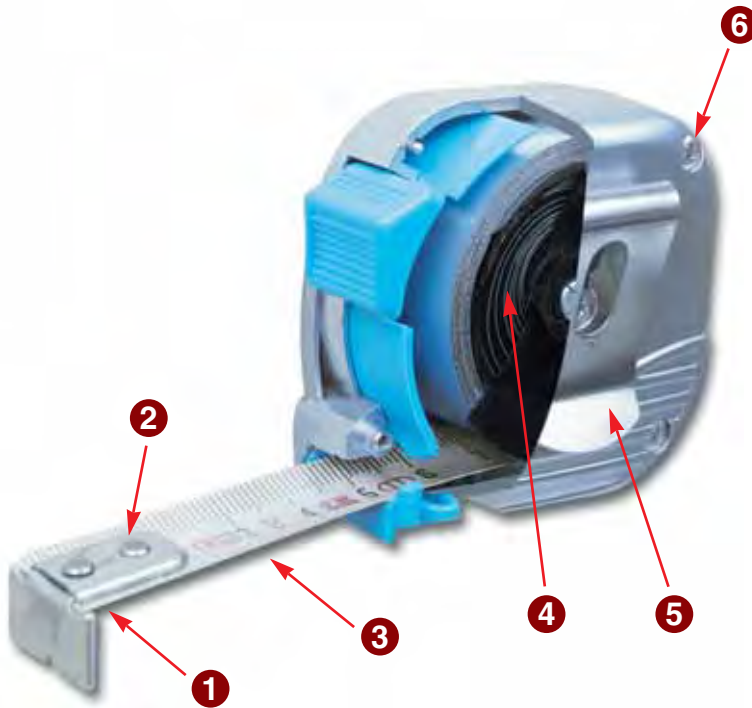

- 1: Uña blindada acero inox.
- 2: Remaches acero inox.
- 3: Cinta metálica acero inox. + nylon coated
- 4: Muelle espiral acero inox.
- 5: Clip acero inox.
- 6: Tornillería acero inox.

- 1: *Stainless steel reinforced hook.*
- 2: *Stainless steel rivets.*
- 3: *Stainless steel +nylon coated measuring tape.*
- 4: *Stainless steel return spring.*
- 5: *Stainless steel belt clip.*
- 6: *Stainless steel screws.*

- 1: Crochet blindé en acier inox.
- 2: Rivets en acier inox.
- 3: Metre ruban en acier inox. + nylon coated
- 4: Ressort en acier inox.
- 5: Clip en acier inox.
- 6: Vis en acier inox.

- 1: *Calciolo blindato in acciaio inox.*
- 2: *Rivetti in acciaio inox.*
- 3: *Nastro in acciaio inox. + nylon coated*
- 4: *Molla di ritorno inox.*
- 5: *Clip in acciaio inox.*
- 6: *Viti in acciaio inox.*



Ref.	m							€
43195	3	19 mm	Inox+Elastollan	●	10	8421411015285		
45195	5	19 mm	Inox+Elastollan	●	5	8421411015292		
45255	5	25 mm	Inox+Elastollan	●	5	8421411015308		
48255	8	25 mm	Inox+Elastollan	●	5	8421411015315		



Estuche muy robusto de acero inoxidable y elastollan, grabado con láser.

Very robust stainless steel plus elastollan case, engraving with laser.

Boiter très robuste acier inoxydable et élastomère, gravé avec laser.

Carcassa rinforzata in acciaio inossidabile e elastomero, impressa a laser.

Pausa inferior muy cómoda

Very comfortable inferior pause

Freiu inférieur très comode.

Doppio freno molto comodo.

Ref.	m						€
25350	2	16 mm	Cromado	●	10	8421411010099	
25351	3	16 mm	Cromado	●	10	8421411010105	
25493	3	19 mm	Cromado	●	10	8421411010112	
25495	5	19 mm	Cromado	●	5	8421411010129	
25537	5	25 mm	Cromado	●	5	8421411010136	
25541	8	25 mm	Cromado	●	5	8421411010143	
25550	10	25 mm	Cromado	●	5	8421411010150	



Ref.	m						€
25581	3	16 mm	ABS	●	10	8421411010723	



Ref.	m						€
5364	2	13 mm	Zamac	●	10	8421411003312	
5365	3	13 mm	Zamac	●	10	8421411003329	



Estuche de Zamac.
Zamac case.
Boiter Zamac.
Carcassa Zamac.

Ref.	m						€
5327	2	16 mm	Acero inox	--	25	8421411003275	
5328	3	16 mm	Acero inox	--	25	8421411003282	



Estuche de acero inoxidable.
Stainless steel case.
Boiter acier inoxydable.
Carcassa di acciaio inossidabile.



Flexómetros UPS
+ Nylon Coated
Classic

UPS measuring tapes
+ Nylon Coated
Classic

Mètres à ruban UPS
+ Nylon Coated
Classic

Flessometri UPS
+ Nylon Coated
Classic





NEW



Ref.	m						€
DT 519	5	19 mm	ABS+Elastollan	●	5	8421411015193	



**Flexómetros UPS
+ Nylon Coated
Classic**



Ref.	m						€
600-02	2	16 mm	ABS	●	10	8421411005569	
600-03	3	16 mm	ABS	●	10	8421411005576	
600-05	5	16 mm	ABS	●	10	8421411003039	
600-02	2	16 mm	ABS	--	25	8421411015797	
600-03	3	16 mm	ABS	--	25	8421411015803	
600-05	5	16 mm	ABS	--	10	8421411015810	



**UPS measuring tapes
+ Nylon Coated
Classic**



Ref.	m						€
600-03Z	3	16 mm	ABS	●	10	8421411014509	
600-05Z	5	16 mm	ABS	●	10	8421411014516	



**Mètres à ruban UPS
+ Nylon Coated
Classic**

Flexómetro especial para zurdos.
Special measuring tape for left-handed people.
Mètre à ruban spécial pour gauchers.
Flessometro speciale per persone mancine.



**Flessometri UPS
+ Nylon Coated
Classic**

**para un zurdo, esta no es manera de medir...
for a left-handed person, this is not way to measure...
pour un gaucher, celle-ci n'est pas façon de mesurer...
un mancino non misura così...**

**¡ESTA SÍ!
THIS YES!
CELLE-CI OUI!
MISURA COSÌ!**

con la cinta impresa en el sentido natural de lectura de las personas zurdas.
with tape printed in the reading natural sense of left-handed people.
avec le ruban imprimé dans le sens naturel de lecture des personnes gauchers.
con la numerazione impressa da destra verso sinistra.



Ref.	m						€
8163	3	16 mm	ABS+Elastollan	●	10	8421411011058	
8195	5	19 mm	ABS+Elastollan	●	5	8421411011065	
8255	5	25 mm	ABS+Elastollan	●	5	8421411011485	
8308	8	30 mm	ABS+Elastollan	●	5	8421411011324	
8163	3	16 mm	ABS+Elastollan	--	36	8421411010921	
8195	5	19 mm	ABS+Elastollan	--	36	8421411010938	
8255	5	25 mm	ABS+Elastollan	--	36	8421411011430	
8308	8	30 mm	ABS+Elastollan	--	10	8421411010945	



Flexómetros
bimaterial modelo
elephant

Elephant two
material measuring
tapes

Mètres à ruban
bi-matière modèle
elephant

Ref.	m						€
8162 pulg.	2	16 mm	ABS+Elastollan	--	36	8421411011720	
8163 pulg.	3	16 mm	ABS+Elastollan	--	36	8421411011737	
8255 pulg.	5	25 mm	ABS+Elastollan	--	36	8421411011744	
8308 pulg.	8	30 mm	ABS+Elastollan	--	10	8421411011751	

Sólo disponible para exportación.

Only available for export.

Seulement exportation.

Solo disponibili per esportazione.



cm + pulgadas

cm + inches

cm + pouces

cm + pollici

Ref.	m						€
6163	3	16 mm	ABS+Elastollan	--	36	8421411009772	



Flessometri
bimateriale modelo
elephant



Flexómetros Big elephant y Center Search

Big elephant and Center Search measuring tapes

Mètres à ruban Big elephant et Center Search

Flessometri Big elephant e Center Search



Ref.	m						€
2515	15	25 mm	ABS+Elastollan	●	5	8421411013007	



15m !!

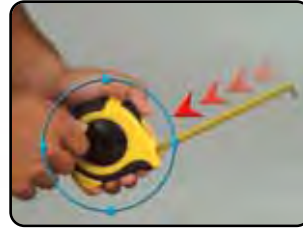
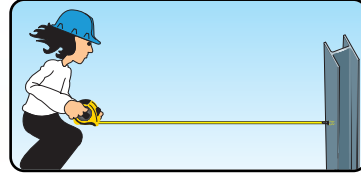

Ref.	m						€
7305	5	25 mm	ABS+Elastollan	●	5	8421411013342	
7308	8	30 mm	ABS+Elastollan	●	5	8421411012994	

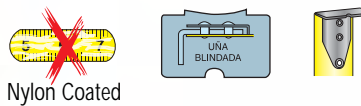

Nylon Coated

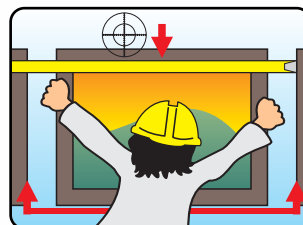
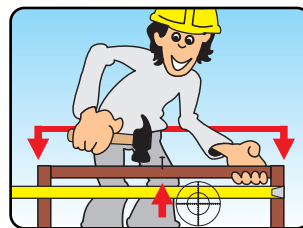
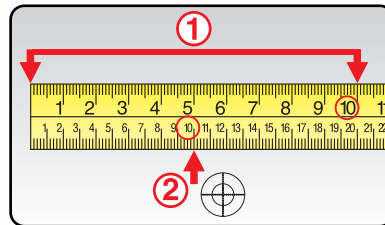

Buscador de centros:

1. Primero lea la distancia total en la escala superior.
2. Después busque el mismo número en la escala inferior. Es el centro.

Center search:

1. First read the distance.
2. Then find the same number here. That's the center.

Chercheur du centre:

1. Tout d'abord, lisez la distance.
2. Repérez ensuite le même nombre. Voilà le centre.

Rilevatore del centro:

1. Prima leggi la distanza.
2. Dopo cerca lo stesso numero qui. Questo è il centro.

MAGNET

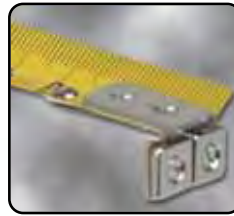

Ref.	m						€
5425	5	25 mm	Cromado Mate	●	5	8 421411 000007	

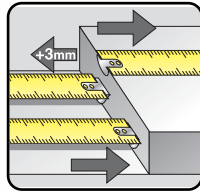

Flexómetros
Magnet, Compact y
Ergo-Magnet

Magnet, Compact
and Ergo-Magnet
measuring tapes

Ref.	m						€
825	8	25 mm	ABS+Elastollan	●	10	8 421411 000007	

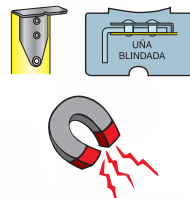
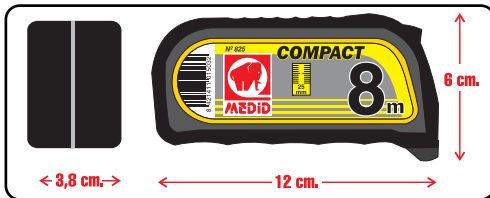

NEW



Mètres à ruban
Magnet, Compact et
Ergo-Magnet

Ref.	m						€
3419M	3	19 mm	ABS+Goma	●	10	8 421411 000007	
5419M	5	19 mm	ABS+Goma	●	5	8 421411 000007	
8425M	8	25 mm	ABS+Goma	●	5	8 421411 000007	
3419M	3	19 mm	ABS+Goma	--	36	8 421411 000007	
5419M	5	19 mm	ABS+Goma	--	36	8 421411 000007	
8425M	8	25 mm	ABS+Goma	--	18	8 421411 000007	

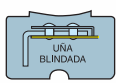

Freno de goma.
Rubber stop.
Frein de gomme.
Freno di gomma.



Flessometri
Magnet, Compact e
Ergo-Magnet

Flexómetros línea standard

Standard line measuring tapes

Mètres à ruban ligne standard

Flessometri linea standard



Ref.	m						€
2193	3	19 mm	ABS+Elastollan	●	10	8421411014011	
2255	5	25 mm	ABS+Elastollan	●	5	8421411014028	
2258	8	25 mm	ABS+Elastollan	●	5	8421411014035	
2193	3	19 mm	ABS+Elastollan	--	36	8421411013762	
2255	5	25 mm	ABS+Elastollan	--	36	8421411013779	
2258	8	25 mm	ABS+Elastollan	--	18	8421411013786	



super-pro

Ref.	m						€
N6283	3	16 mm	ABS+Elastollan	●	10	8421411007051	
N6285	5	16 mm	ABS+Elastollan	●	5	8421411007068	
N6295	5	19 mm	ABS+Elastollan	●	5	8421411008126	
N6283	3	16 mm	ABS+Elastollan	--	25	8421411009260	
N6285	5	16 mm	ABS+Elastollan	--	25	8421411009277	
N6295	5	19 mm	ABS+Elastollan	--	25	8421411009239	

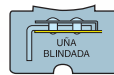

Ref.	m						€
NCL-1316	3	16 mm	Cromado+Elast.	●	10	8421411014158	
NCL-1519	5	19 mm	Cromado+Elast.	●	10	8421411014165	
NCL-1825	8	25 mm	Cromado+Elast.	●	5	8421411014172	
NCL-1316	3	16 mm	Cromado+Elast.	--	40	8421411014455	
NCL-1519	5	19 mm	Cromado+Elast.	--	25	8421411014462	
NCL-1825	8	25 mm	Cromado+Elast.	--	10	8421411014479	



Nylon Coated

Ref.	m						€
9193	3	19 mm	ABS+Goma	Colgador	21	8421411012154	
9255	5	25 mm	ABS+Goma	Colgador	18	8421411012161	
9308	8	32 mm	ABS+Goma	Colgador	15	8421411012178	

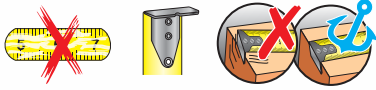

Flexómetros línea standard

Ref.	m						€
3419	3	19 mm	ABS+Goma	●	10	8421411014042	
5419	5	19 mm	ABS+Goma	●	5	8421411014059	
8425	8	25 mm	ABS+Goma	●	5	8421411014066	
3419	3	19 mm	ABS+Goma	--	36	8421411012505	
5419	5	19 mm	ABS+Goma	--	36	8421411012512	
8425	8	25 mm	ABS+Goma	--	18	8421411012529	

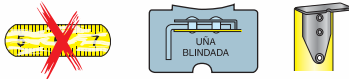

Uña transparente.
Transparent hook.
Crochet transparent.
Calciolo trasparente.

NEW



Standard line measuring tapes

Ref.	m						€
400-02	2	13 mm	ABS	●	25	8421411002957	
400-03	3	13 mm	ABS	●	25	8421411002964	
500-02	2	13 mm	ABS	●	25	8421411002971	
500-03	3	13 mm	ABS	●	25	8421411002988	
500-05	5	16 mm	ABS	●	10	8421411008287	
400-02	2	13 mm	ABS	--	25	8421411015827	
400-03	3	13 mm	ABS	--	25	8421411015834	
500-02	2	13 mm	ABS	--	25	8421411015841	
500-03	3	13 mm	ABS	--	25	8421411015858	
500-05	5	16 mm	ABS	--	10	8421411015865	

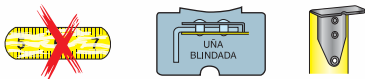

400-03

500-03

Mètres à ruban ligne standard

Ref.	m						€
9312	2	13 mm	Cromado	--	50	8421411010242	
9313	3	13 mm	Cromado	--	50	8421411010259	
9319	5	19 mm	Cromado	--	25	8421411010266	
9325	5	25 mm	Cromado	--	25	8421411010273	



Colores surtidos.
Assorted colours.
Assortiment de couleurs.
Color assortiti.



Flessometri linea standard

Flexómetros línea standard

Standard line measuring tapes

Mètres à ruban ligne standard

Flessometri linea standard







Ref.	m						€
6282	2	16 mm	ABS	●	10	8421411007044	
6282	2	16 mm	ABS	--	84	8421411009253	





Ref.	m						€
6132	2	13 mm	ABS	●	10	8421411009079	
6133	3	13 mm	ABS	●	10	8421411009093	
6163A	3	16 mm	ABS	●	10	8421411009789	
6132	2	13 mm	ABS	--	60	8421411009062	
6133	3	13 mm	ABS	--	60	8421411009086	
6163A	3	16 mm	ABS	--	50	8421411009772	

Ref.	m						€
CL-1219	2	19 mm	Cromado	●	10	8421411010907	
CL-1313	3	13 mm	Cromado	●	10	8421411010846	
CL-1319	3	19 mm	Cromado	●	10	8421411010860	
CL-1519	5	19 mm	Cromado	●	5	8421411010877	
CL-1525	5	25 mm	Cromado	●	5	8421411010884	
CL-1825	8	25 mm	Cromado	●	5	8421411010891	
CL-1025	10	25 mm	Cromado	●	5	8421411010815	
CL-1219	2	19 mm	Cromado	--	25	8421411015872	
CL-1313	3	13 mm	Cromado	--	25	8421411015896	
CL-1319	3	19 mm	Cromado	--	25	8421411015902	
CL-1519	5	19 mm	Cromado	--	10	8421411015919	
CL-1525	5	25 mm	Cromado	--	10	8421411015926	
CL-1825	8	25 mm	Cromado	--	5	8421411015933	
CL-1025	10	25 mm	Cromado	--	5	8421411015940	





Ref.	m						€
CL-1313sf	3	13 mm	Cromado	●	10	8421411010839	
CL-1313sf	3	13 mm	Cromado	--	25	84214110105889	

Ref.	m						€
9012	2	13 mm	ABS	--	25	8421411005941	
9013	3	13 mm	ABS	--	25	8421411005958	
9015	5	13 mm	ABS	--	10	8421411005965	



Ref.	m						€
9002	2	13 mm	ABS	--	25	8421411005927	
9003	3	13 mm	ABS	--	25	8421411005934	



Ref.	m						€
9912	2	13 mm	ABS	--	25	8421411015704	
9913	3	13 mm	ABS	--	25	8421411015711	

Ref.	m						€
5012	1	7 mm	ABS+Goma	--	25	8421411003060	



 = 85 u.



Flexómetros línea standard

Standard line measuring tapes

Mètres à ruban ligne standard

Flessometri linea standard

Flexómetros especiales

Special measuring tapes

Mètres à ruban spéciaux

Flessometri speciali



Ref.	m	mm	Material	Color	Quantity	Barcode	€
5417	3	16 mm	ABS	•	10	8421411006252	



Medición de interiores.
Inside measurements.
 Mesures intérieures.
 Misura di interni.



Ref.	m	mm	Material	Color	Quantity	Barcode	€
900	3	13 mm	ABS	•	25	8421411012055	

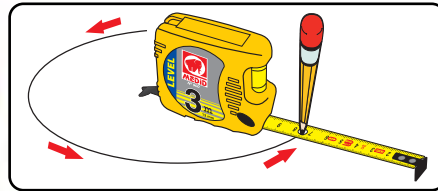

Ref.	m	mm	Material	Color	Quantity	Barcode	€
5391	3	7 mm	ABS+Aluminio	Skin	25	8421411003374	

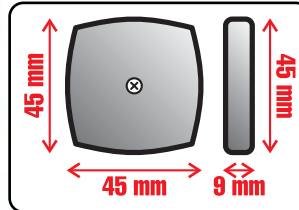

Extraplano.
Extraflat.
 Extraplat.
 Superpiatto.



Ref.	m	mm	Material	Color	Quantity	Barcode	€
5393	3	7 mm	ABS+Aluminio	Skin	25	8421411013755	

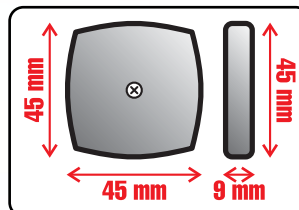

Extraplano.
Extraflat.
 Extraplat.
 Superpiatto.



Medidor de diámetros.
Diameter measurer.
 Mesureur de diamètres.
 Misuratore di diametri.

Ref.	Descripción				€
9999	Cartuchera	--	10	8421411010471	

Ref.	Descripción				€
99995	Cuelga-flexómetros	--	10	8421411012208	

Ref.	Descripción				€
990	Cuelga-flexómetros	--	10	8421411013991	



Ref.	Descripción				€
992	Portalápiz	--	25	8421411014004	



Ref.	Descripción			€
SKIN	Plastic-Skin	--	--	

Ref.	Descripción			€
COLG	Colgador plástico	--	--	

Ref.	Descripción			€
BLISTER	Doble blister	--	--	



Accesorios y presentaciones

Accessories and packing

Accessoires et emballages

Accessori e presentazioni



Cintas métricas

Long tapes

Mètres souples

Rotelle metriche

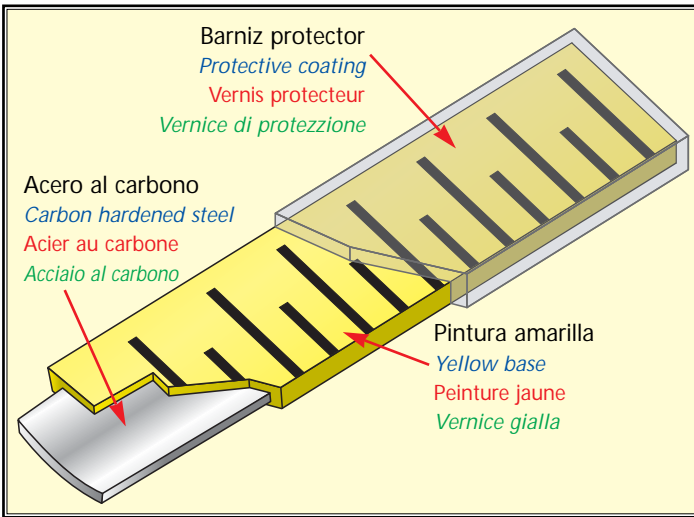

CINTAS MÉTRICAS METÁLICAS:
De acero templado, milimetradas. Las cintas metálicas se aconsejan para la medición profesional y muy exacta de distancias. PRECISIÓN CLASE II (Homologación CEE) de menor tolerancia, es decir **MAYOR PRECISIÓN**.

STEEL LONG TAPES:
Tempered steel tape, 1 mm scale interval. Steel long tapes are suitable for professional measurements with **ACCURACY CLASS II (EEC approval)**, less tolerance means **HIGHER ACCURACY**.

MESURES LONGUES METALLIQUES:
Ruban en acier trempé, à échelle millimétrique, pour la mesure professionnelle et très exacte. **PRECISION CLASSE II (Homologation CEE)**, de moins tolerance, c'est à dire, **PLUS PRECISION**.

NASTRI METALLICI:
Nastro in acciaio temperato, millimetrato. Consigliato per la misurazione professionale in quanto risulta molto esatta. Omologati secondo la Normativa CEE, **CLASSE DI PRECISIONE II**, per tanto **PIÙ PRECISIONE**.

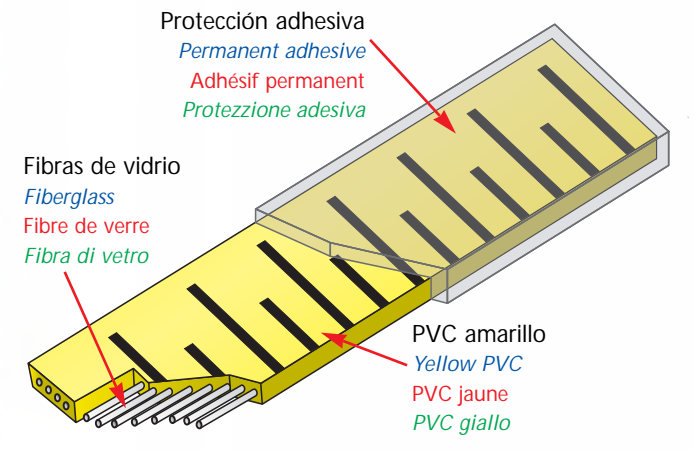

CINTAS MÉTRICAS DE FIBRA DE VIDRIO:
Recomendables para la medición de largas distancias por su menor peso, flexibilidad y duración; por ser lavables, no conductoras de la electricidad y resistentes a la abrasión y tensión.

FIBER GLASS TAPES:
Comfortable to use in long distances measurement due to the light weight, flexibility and longlasting. Washables, non conducting and resistant to abrasion and tension.

MÈTRES SOUPLES EN FIBRE DE VERRE:
Les mesures en fibre de verre offrent une grand comodité d'usage par sa légèreté, flexibilité et longue durée. Lavables, non conducteurs et résistants à l'abrasion et la tension.

NASTRI IN FIBRA DI VETRO:
I nastri in fibra di vetro offrono una grande comodità d'uso, per la sua leggerezza, flessibilità e lunga durata. Lavabile, non conduttore e resistente alle abrasioni.

Fibra de Vidrio en CLASE II = DOBLE PRECISIÓN / Fiberglass in CLASS II = DOUBLE ACCURACY
Fibre de Verre en CLASSE II = 2 FOIS PLUS PRÉCIS / Fibra di Vetro in CLASSE II = DOPPIA PRECISIONE

NEW

- 1: Hebras paralelas de fibra de vidrio.
- 2: Revestimiento plástico.
- 3: Revestimiento transparente que protege el marcaje de la cinta. Muy resistente al desgaste. Ligero. Flexible. Lavable. No conductor eléctrico en seco.

- 1: Parallel strands of fiberglass.
- 2: Plastic coating.
- 3: Transparent coating protects blade graphics, highly resistant to mechanical and chemical abrasion. Lightweight. Pliable. Virtually stretch-free. Washable. Electrically non-conductive.

- 1: Fils de fibre de verre.
- 2: Enrobage en matière plastique souple.
- 3: Enrobage transparent. Hautement résistant à l'abrasion mécanique et aux agents chimiques. Assure une parfaite protection de la graduation imprimée. Ruban léger, souple, non élastique, lavable, non conducteur d'électricité.

- 1: Filamenti paralleli in fibra di vetro.
- 2: Rivestimento in plastica.
- 3: La pellicola trasparente protegge la stampa del nastro, ottima resistenza all'abrasione meccanica ed agli agenti chimici. Leggero. Flessibile. Immune da fenomeni di elongazione. Lavabile. Non conduttore di elettricità.

CUADRO DE TOLERANCIAS / TOLERANCE TABLE / TABLEAU DE TOLÉRANCES / TABELLA DI TOLLERANZA

PRECISIÓN ACCURACY PRECISION PRECISIONE	LONG./TOLERANCIA LENGHT/TOLERANCE LONG./TOLERANCE LUNG./TOLLERANZA (± mm)									
	1 m	2 m	3 m	5 m	8 m	10 m	20 m	30 m	50 m	100 m
II	0,5	0,7	0,9	1,3	1,9	2,3	4,3	6,3	10,3	20,3
III	1,0	1,4	1,8	2,6	3,8	4,6	8,6	12,6	20,6	40,6

PRINCIPIO ESPAÑOL: El punto "0" está en el extremo de la cinta.
PRINCIPIO CEE: El punto "0" se encuentra en la uña.

SPANISH STARTING: "0" point at the end of the hook.
CEE STARTING: "0" point on the foldable hook.

ZERO ESPAÑOL: "0" est au bout de l'anneau.
ZERO CEE: Zéro à la boucle avec crochet rabattable.

PARTENZA SPAGNOLA: Lo "0" è situato alla fine dell' anello.
PARTENZA CEE: Lo "0" è posizionato sul gancio.



PRINCIPIO CEE
CEE STARTING
ZERO CEE
PARTENZA CEE

PRINCIPIO ESPAÑOL
SPANISH STARTING
ZERO ESPAÑOL
PARTENZA SPAGNOLA



Ref.	m						€
1360	10	15 mm	Metal+Piel	●	2	8421411004920	
1360	15	15 mm	Metal+Piel	●	2	8421411004937	
1360	20	15 mm	Metal+Piel	●	2	8421411004944	
1360	25	15 mm	Metal+Piel	●	2	8421411004951	
1360	30	15 mm	Metal+Piel	●	2	8421411004968	
1360	50	15 mm	Metal+Piel	●	2	8421411004975	

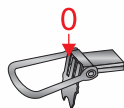

clase II



Ref.	m						€
1110	10	15 mm	Metal+Piel	●	2	8421411013748	

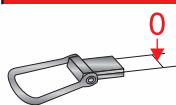

clase II



Medidor de diámetros.
Diameter measurer.
Mesureur de diamètres.
Misuratore di diametri.

Ref.	m						€
1660	40	15 mm	ABS+Elastollan	●	1	8421411013892	
1660	60	15 mm	ABS+Elastollan	●	1	8421411013458	

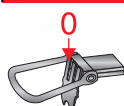

clase II



Ref.	m						€
1650	30	18 mm	ABS+Elastollan	●	1	8421411015025	

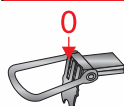

+ 30%
Hebras de fibra de vidrio
Strands of fiberglass
Fils de fibre de verre
Filamenti in fibra di vetro

clase II



NEW

Cintas métricas
fibra de vidrio
clase II milimetradas

1 mm scale
fiberglass tapes
class II

Mètres souples en
fibre de verre classe II
millimètres

Rotelle metriche
nastro fibra di vetro
clase II millimetre



Cintas métricas
fibra de vidrio
clase III



Ref.	m	15 mm	ABS+Elastollan	●	1	8421411 000007	€
1975	30	15 mm	ABS+Elastollan	●	1	8421411011829	
1975	50	15 mm	ABS+Elastollan	●	1	8421411011836	

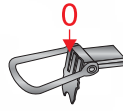

Fiberglass tapes
class III



Ref.	m	15 mm	ABS	Caja	1	8421411 000007	€
1775	30	15 mm	ABS	Caja	1	8421411007006	
1775	50	15 mm	ABS	Caja	1	8421411007013	
1775	100	15 mm	ABS	Caja	1	8421411007020	

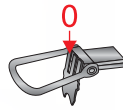

Mètres souples en
fibre de verre
clase III



Ref.	m	15 mm	ABS+Elastollan	●	1	8421411 000007	€
1500	10	15 mm	ABS+Elastollan	●	1	8421411011782	
1500	20	15 mm	ABS+Elastollan	●	1	8421411011799	
1500	30	15 mm	ABS+Elastollan	●	1	8421411011805	
1500	50	15 mm	ABS+Elastollan	●	1	8421411011812	

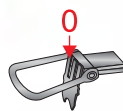





Rotelle metriche
nastro fibra di vetro
clase III



FLUOR

Ref.	m	15 mm	ABS	●	2	8421411 000007	€
1400	10	15 mm	ABS	●	2	8421411009574	
1400	15	15 mm	ABS	●	2	8421411009581	
1400	20	15 mm	ABS	●	2	8421411009598	
1400	25	15 mm	ABS	●	2	8421411009604	
1400	30	15 mm	ABS	●	2	8421411009611	
1400	50	15 mm	ABS	●	2	8421411009628	



Ref.	m						€
1210 GF	10	15 mm	ABS	●	2	8421411004623	
1210 GF	15	15 mm	ABS	●	2	8421411004630	
1210 GF	20	15 mm	ABS	●	2	8421411004647	
1210 GF	25	15 mm	ABS	●	2	8421411004654	
1210 GF	30	15 mm	ABS	●	2	8421411004661	
1210 GF	50	15 mm	ABS	●	2	8421411006238	
1211 GF	50	15 mm	ABS	●	2	8421411004685	

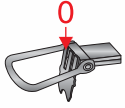





1211



1210





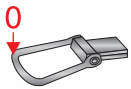

Cintas métricas
fibra de vidrio
clase III

Ref.	m						€
1210 ESP	10	15 mm	ABS	Caja	1	8421411015957	
1210 ESP	15	15 mm	ABS	Caja	1	8421411015964	
1210 ESP	20	15 mm	ABS	Caja	1	8421411015971	
1210 ESP	25	15 mm	ABS	Caja	1	8421411015988	
1210 ESP	30	15 mm	ABS	Caja	1	8421411015995	
1210 ESP	50	15 mm	ABS	Caja	1	8421411016008	





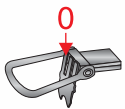

Fiberglass tapes
class III

Ref.	m						€
1200	10	15 mm	ABS	Caja	1	8421411006931	
1200	15	15 mm	ABS	Caja	1	8421411006948	
1200	20	15 mm	ABS	Caja	1	8421411006955	
1200	25	15 mm	ABS	Caja	1	8421411006962	
1200	30	15 mm	ABS	Caja	1	8421411006979	
1200	50	15 mm	ABS	Caja	1	8421411009055	



Mètres souples en
fibre de verre
classe III

Ref.	m						€
1300	10	13 mm	ABS	●	2	8421411010167	
1300	20	13 mm	ABS	●	2	8421411010174	
1300	30	13 mm	ABS	●	2	8421411011768	
1300	50	13 mm	ABS	●	2	8421411011775	

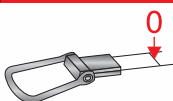

0 Inicio italiano.
Italian starting.
Principe italiano.
Principio italiano.

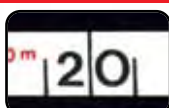

Rotelle metriche
nastro fibra di vetro
classe III



NEW



Ref.	m	13 mm	ABS+Elast.+Alu.	●	1	8 421411 000007	€
2760	50	13 mm	ABS+Elast.+Alu.	●	1	8421411014967	
2760	100	13 mm	ABS+Elast.+Alu.	●	1	8421411014974	

GB HIGH SPEED RETURN
 I ALTA VELOCITÀ DI RITORNO
 F HAUTE VELOCITÉ DE RETOUR
 ALTA VELOCIDAD DE RETORNO **3:1**

Cintas métricas metálicas clase II



Ref.	m	13 mm	ABS+Elast.+Alu.	Maleta	1	8 421411 000007	€
2660	30	13 mm	ABS+Elast.+Alu.	Maleta	1	8421411011843	
2660	50	13 mm	ABS+Elast.+Alu.	Maleta	1	8421411009147	
2660	30	13 mm	ABS+Elast.+Alu.	●	1	8421411011843	
2660	50	13 mm	ABS+Elast.+Alu.	●	1	8421411009147	

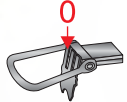

Steel tapes class II



Ref.	m	13 mm	ABS+Elast.+Alu.	Maleta	1	8 421411 000007	€
2675	30	13 mm	ABS+Elast.+Alu.	Maleta	1	8421411005675	
2675	50	13 mm	ABS+Elast.+Alu.	Maleta	1	8421411005682	

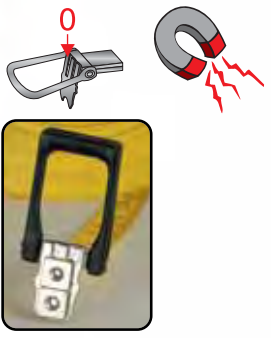

Mètres souples métalliques classe II



Ref.	m	13 mm	ABS+Elast.+Alu.	Maleta	1	8 421411 000007	€
2675	100	13 mm	ABS+Elast.+Alu.	Maleta	1	8421411005859	

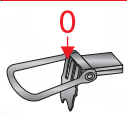

Rotelle metriche nastro acciaio classe II

Ref.	m						€
2700	50	12 mm	ABS+Elastollan	●	1	8421411014981	

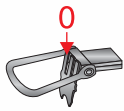

Inicio protegido con plástico.
Protected starting with plastic.
 Début protégé avec plastique.
Inizio protetto in plastica.



Ref.	m						€
2650	10	12 mm	Metal+Piel	●	2	8421411005187	
2650	15	12 mm	Metal+Piel	●	2	8421411005194	
2650	20	12 mm	Metal+Piel	●	2	8421411005200	
2650	25	12 mm	Metal+Piel	●	2	8421411005217	
2650	30	12 mm	Metal+Piel	●	2	8421411005224	
2650	50	12 mm	Metal+Piel	●	2	8421411005231	

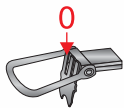

2650 ESP	30	12 mm	Metal+Piel	●	2	8421411015735	
2650 ESP	50	12 mm	Metal+Piel	●	2	8421411015742	

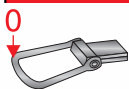

Ref.	m						€
2640	10	13 mm	ABS+Elastollan	●	1	8421411005040	
2640	15	13 mm	ABS+Elastollan	●	1	8421411005057	
2640	20	13 mm	ABS+Elastollan	●	1	8421411005064	
2640	25	13 mm	ABS+Elastollan	●	1	8421411005071	
2640	30	13 mm	ABS+Elastollan	●	1	8421411005088	
2640	50	13 mm	ABS+Elastollan	●	1	8421411005095	

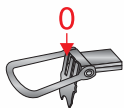

Ref.	m						€
185	15	10 mm	ABS	●	1	8421411015018	

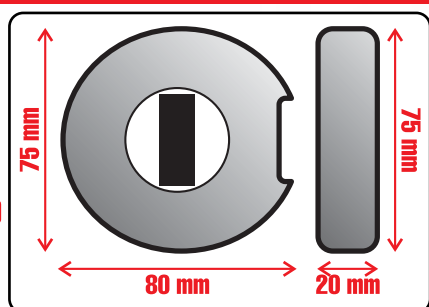
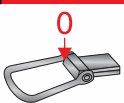

COMPACT

NEW



Cintas métricas
metálicas classe II

Steel tapes
class II

Mètres souples
métalliques classe II

Rotelle metriche
nastro acciaio classe II



Sondas



Ref.	m						€
2961	10	13 mm	ABS+Elast.+Alu.	Maleta	1	8421411005484	
2961	20	13 mm	ABS+Elast.+Alu.	Maleta	1	8421411005491	
2961	30	13 mm	ABS+Elast.+Alu.	Maleta	1	8421411005507	

Ref. 2961: Sonda de acero inoxidable. Números grabados.
Para agua, disolventes y mezclas ligeramente ácidas.

*Ref. 2961: Stainless steel dip weight. Engraved numbers.
Water, solvents and slightly acid mix.*

*Ref. 2961: Sonde en acier inoxydable. Numéros gravés.
Pour eau, dissolvants et melanges acides.*

*Ref. 2961: Sonda di acciaio inossidabile. Numerazione incisa.
Per acqua, solventi e miscele acide.*

Tank dipping tapes



Ref.	m						€
2940	10	13 mm	ABS+Elast.+Alu.	Maleta	1	8421411005422	
2940	20	13 mm	ABS+Elast.+Alu.	Maleta	1	8421411005446	
2940	30	13 mm	ABS+Elast.+Alu.	Maleta	1	8421411005460	

Ref. 2940: Sonda de acero al carbono. Números grabados.
Para aceites y similares. Ciertos disolventes.

*Ref. 2940: Carbon steel dip weight. Engraved numbers.
Oils or similars. Some solvents.*

*Ref. 2940: Sonde en acier carbone. Numéros gravés.
Pour huiles et similaires. Quelques dissolvants.*

*Ref. 2940: Sonda di acciaio al carbonio. Numerazione incisa.
Per oli e similari. Alcuni solventi.*

Sondes



Ref.	m						€
2915	10	13 mm	ABS+Elast.+Alu.	Maleta	1	8421411005323	
2915	20	13 mm	ABS+Elast.+Alu.	Maleta	1	8421411005347	
2915	30	13 mm	ABS+Elast.+Alu.	Maleta	1	8421411005361	

Ref. 2915: Sonda de acero esmaltado.
Para aceites y sustancias no oxidantes.

*Ref. 2915: Enameled steel dip weight.
Oils and no rusting substances.*

*Ref. 2915: Sonde de acier emaille.
Pour huiles et substance non oxydantes.*

*Ref. 2915: Sonda di acciaio smaltato.
Per oli e sostanze non ossidanti.*

Sonde



NIVELES DE BURBUJA: Sólidos y precisos, con una precisión desde 0,5 mm/m = 0,0285° hasta 1 mm/m = 0,057° según modelo. Precisión de 0,5 mm/m (controlada por ordenador) significa que un nivel de 1 metro permite máximo 0,5 mm de diferencia respecto a la línea horizontal en una u otra punta del nivel, bajo la condición que la burbuja permanezca centrada entre las dos líneas de la burbuja.

WATER LEVELS: Strong and accurated, the accuracy reach the 0,5 mm/m = 0,0285° to 1 mm/m = 0,057° depending on models. Accuracy 0,5 mm/m (electronically tested) means that a level that is 1 m long allows max. 0,5 mm faults of horizontal line on one or the other side of the level, under the condition, that the bubble in the vial is precisely in the middle of the marking rings.

NIVEAUX A BULLE: Solides et précis, avec une précision de 0,5 mm/m = 0,0285° jusqu'à 1 mm/m = 0,057° selon les modèles. Précision de 0,5 mm/m (contrôlée électroniquement) signifie qu'un niveau d'1 mètre permet un maximum de 0,5 mm de différence sur la ligne horizontale, ou sur quelconque autre point du niveau, sous la condition que la bulle soit bien centrée entre les deux lignes.

LIVELLA A BOLLA: Solide e precise, con una precisione di 0,5 mm/m = 0,0285° fino a 1 mm/m = 0,057° a seconda del modello. Precisione di 0,5 mm/m (testata elettronicamente) significa che una livella di 1 metro ammette, rispetto alla superficie orizzontale, un massimo di 0,5 mm de differenza fra i due stremi della livella, sempre che la bolla d'aria rimanga nella stessa identica posizione, centrata fra le due linee impresse su la bolla.

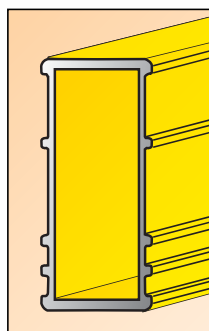
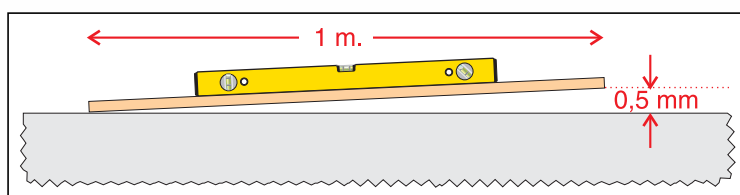
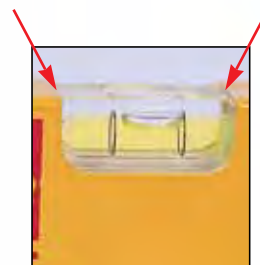

Más resistentes gracias a sus perfiles de aluminio de mayor espesor.

More resistant thanks to the enlarged thickness of the aluminium profiles.

Plus résistant dû à la grande épaisseur des profiles alu.

Piú resistente grazie ad profilati alluminio di maggior spessore.

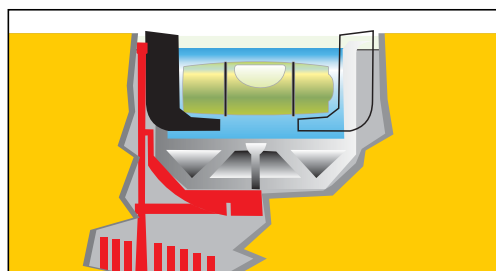

Burbujas de cristal acrílico torneado, herméticamente selladas y dotadas de anillos de lectura anticorrosión. Su líquido especial fluorescente presenta una gran resistencia a los rayos U.V. y configura una burbuja muy definida y perfectamente visible. De gran estabilidad, ofrece mediciones fiables entre -20°C y +40°C. El bloque de la burbuja se aloja en el cuerpo del nivel sobre materiales que le otorgan una gran protección a golpes y estabilidad absoluta.

Turned acrylic glass vials, tightly welded to inset, corrosion-proof read-off rings. Its special fluorescent solution is highly resistant to UV radiation and ensures an easlily readable bubble. Its high stability ensures precise readings at temperatures from -20°C to +40°C. The vial unit is located in the level's body surrounded by materials which give it an absolute protection and stability.

Bulles de verre acrylique tourné, scellées pour empêcher toute fuite et avec des anneaux de lecture anti-corrosion. Le liquide spécial fluorescent présente une haute résistance aux rayonnements UV et produit une bulle facilement lisible. De grande stabilité, offre des lectures précises même à des températures de -20°C à +40°C. Le bloc de bulle est logé dans le corps du niveau sur des matériels qui lui confèrent une grande protection et stabilité absolue.

Bolle da plexiglas tornito, saldate a tenuta ermetica e con anelli di lettura resistenti alla corrosione. Lo speciale liquido fluorescente possiede un'elevata resistenza ai raggi UV, e garantisce la buona leggibilità della bolla. Per la sua stabilità, è possibile una lettura esatta con temperature comprese tra i -20°C i +40°C. La bolla è inserita nella livella su materiali che li danno una grande protezione e stabilità.

TIPOS DE BURBUJAS / TYPES OF VIALS / TYPES DE BULLES / TIPI DI BOLLA



Fija para medición horizontal
For horizontal reading
Pour mesure horizontale
Per lettura orizzontale

Fija para medición vertical
For vertical reading
Pour mesure verticale
Per lettura verticale

Fija para medición a 45°
For 45° angle reading
Pour mesure à 45°
Per lettura a 45°



Nivelación

Leveling

Nivelation

Livellatura



Top Quality



Niveles profesionales de precisión

Professional levels accuracy

Niveau professionnel de précision

Livelle professionale di precisione

Ref.	mm						€
10030	300	2	0,5 mm/m	--	1	8421411003954	
10040	400	2	0,5 mm/m	--	1	8421411003961	
10050	500	2	0,5 mm/m	--	1	8421411003992	
10060	600	2	0,5 mm/m	--	1	8421411004029	
10080	800	2	0,5 mm/m	--	1	8421411014651	

10040M	400	2	0,5 mm/m	--	1	8421411014202	
10050M	500	2	0,5 mm/m	--	1	8421411014219	
10060M	600	2	0,5 mm/m	--	1	8421411014226	
10080M	800	2	0,5 mm/m	--	1	8421411014653	

Garantía 7 años. / 7 years warranty. / 7 ans de garantie. / Garanzia 7 anni.

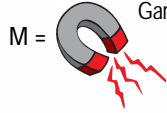

M =

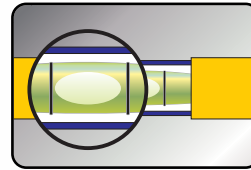
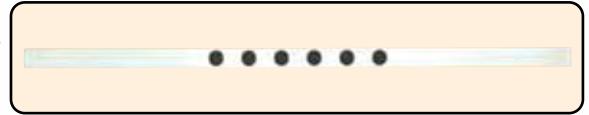

Burbuja horizontal con lupa
Horizontal vial with magnifying
Bulle horizontale avec loupe
Bolla orizzontale con lente

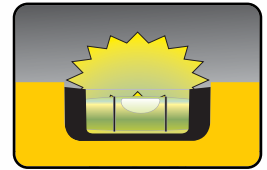

Burbuja horizontal con efecto fosforescente
Horizontal vial with fosforescent background
Bulle horizontale avec effet fosforescent
Bolla orizzontale con effetto fluorescente

Top Quality



Ref.	mm						€
20030	300	3	0,5 mm/m	--	1	8421411004098	
20040	400	3	0,5 mm/m	--	1	8421411004111	
20050	500	3	0,5 mm/m	--	1	8421411004135	
20060	600	3	0,5 mm/m	--	1	8421411004159	
20080	800	3	0,5 mm/m	--	1	8421411004173	
20100	1000	3	0,5 mm/m	--	1	8421411004388	
20120	1200	3	0,5 mm/m	--	1	8421411004395	
20150	1500	3	0,5 mm/m	--	1	8421411008300	
20200	2000	3	0,5 mm/m	--	1	8421411008317	

20040M	400	2	0,5 mm/m	--	1	8421411004128	
20050M	500	2	0,5 mm/m	--	1	8421411004142	
20060M	600	2	0,5 mm/m	--	1	8421411004166	

Garantía 7 años. / 7 years warranty. / 7 ans de garantie. / Garanzia 7 anni.



M =

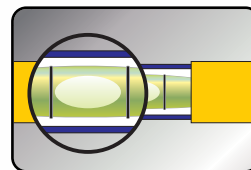

Burbuja horizontal con lupa
Horizontal vial with magnifying
Bulle horizontale avec loupe
Bolla orizzontale con lente



Burbuja horizontal con efecto fosforescente
Horizontal vial with fosforescent background
Bulle horizontale avec effet fosforescent
Bolla orizzontale con effetto fluorescente

Ref.	mm						€
16060	600	3	0,5 mm/m	--	1	8421411013625	
16080	800	3	0,5 mm/m	--	1	8421411013632	
16100	1000	3	0,5 mm/m	--	1	8421411013649	

Base y parte superior rectificada.

Rectified base and upper side.

Base et partie supérieure rectifiée.

Base e parte superiore rettificata.



Niveles profesionales de precisión

Ref.	mm						€
23040	400	3	1 mm/m	--	1	8421411014745	
23060	600	3	1 mm/m	--	1	8421411014752	
23080	800	3	1 mm/m	--	1	8421411014769	
23100	1000	3	1 mm/m	--	1	8421411014776	
23120	1200	3	1 mm/m	--	1	8421411014783	
23150	1500	3	1 mm/m	--	1	8421411014790	
23180	1800	3	1 mm/m	--	1	8421411014806	
23200	2000	3	1 mm/m	--	1	8421411014813	

Base y parte superior rectificada.

Rectified base and upper side.

Base et partie supérieure rectifiée.

Base e parte superiore rettificata.



Professional levels accuracy

Niveau professionnel de précision

23040M	400	3	1 mm/m	--	1	8421411014820	
23060M	600	3	1 mm/m	--	1	8421411014837	
23080M	800	3	1 mm/m	--	1	8421411014844	
23100M	1000	3	1 mm/m	--	1	8421411014851	
23120M	1200	3	1 mm/m	--	1	8421411014868	
23150M	1500	3	1 mm/m	--	1	8421411014875	
23180M	1800	3	1 mm/m	--	1	8421411014882	
23200M	2000	3	1 mm/m	--	1	8421411014899	

Parte superior rectificada.

Rectified upper side.

Partie supérieure rectifiée.

Parte superiore rettificata.

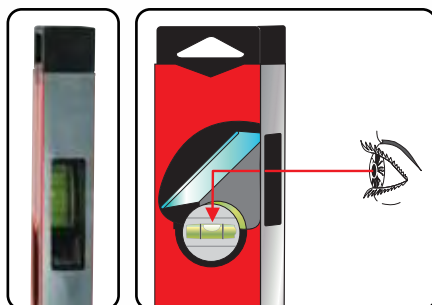

Lectura indirecta

Undirect reading

Lecture indirecte

Lettura indiretta

NO DISPONIBLE EXPORT
NOT AVAILABLE EXPORT
PAS DISPONIBLE POUR EXPORT
NON DISPONIBILE EXPORT

Livelle professionale di precisione



Niveles profesionales de precisión



Professional levels accuracy



Niveau professionnel de précision



Livelle professionale di precisione

Ref.	mm						€
27030	300	3	1 mm/m	--	1	8421411008492	
27040	400	3	1 mm/m	--	1	8421411008508	
27050	500	3	1 mm/m	--	1	8421411008515	
27060	600	3	1 mm/m	--	1	8421411008522	
27080	800	3	1 mm/m	--	1	8421411008539	
27100	1000	3	1 mm/m	--	1	8421411010952	
27120	1200	3	1 mm/m	--	1	8421411010969	
27150	1500	3	1 mm/m	--	1	8421411010976	

27040M	400	3	1 mm/m	--	1	8421411010983	
27050M	500	3	1 mm/m	--	1	8421411010990	
27060M	600	3	1 mm/m	--	1	8421411011003	



Ref.	mm						€
17030	300	2	1 mm/m	--	1	8421411012277	
17040	400	2	1 mm/m	--	1	8421411012284	
17050	500	2	1 mm/m	--	1	8421411012291	
17060	600	2	1 mm/m	--	1	8421411012307	

17040M	400	2	1 mm/m	--	1	8421411013045	
17050M	500	2	1 mm/m	--	1	8421411013052	
17060M	600	2	1 mm/m	--	1	8421411013069	

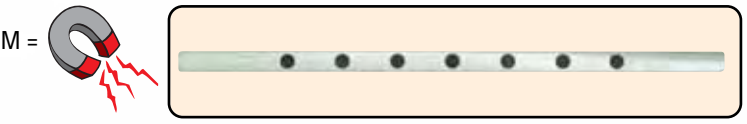

Ref.	mm						€
28030	300	3	1 mm/m	--	1	8421411010617	
28040	400	3	1 mm/m	--	1	8421411010624	
28050	500	3	1 mm/m	--	1	8421411010631	
28060	600	3	1 mm/m	--	1	8421411010648	
28080	800	3	1 mm/m	--	1	8421411010655	

Base y parte superior rectificada.
Rectified base and upper side.
 Base et partie supérieure rectifiée.
Base e parte superiore rettificate.

Ref.	mm						€
NMA 60	600	6	1 mm/m	--	1	8421411012642	

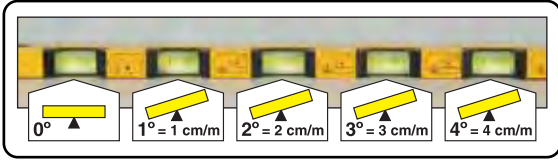

LASER

Nivel para pendientes.

Level for slope.

Niveau pour inclinaison.

Livella per fare piani inclinati.

Ref.	mm						€
2010	600	2	± 0,2	--	1	8421411012321	

DIGITAL

LASER

Nivel digital.

Digital level.

Niveau digitale.

Livella digitale.

Ref.	mm						€
Pro360	150	0	± 0,2	--	1	8421411015049	

DIGITAL

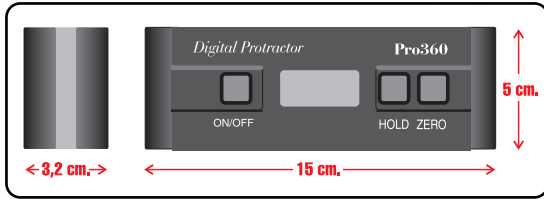

NEW

Ref.	mm						€
SC03	2000	2	1 mm/m	--	1	8421411013434	

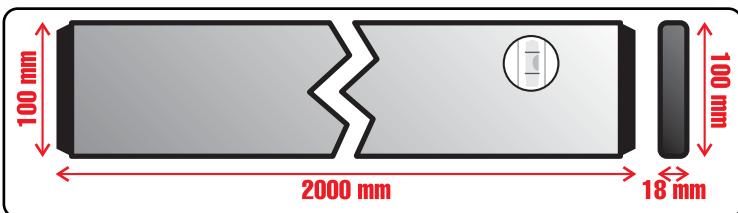

Regla-nivel-aplanador.

Rule-level-leveller.

Regle-niveau-aplanisseuse.

Riga-livella-livellatrice-staggera.



Niveles especiales

Special levels

Niveaux spéciaux

Livelle speciali



Niveles especiales



Ref.	mm						€
560	600	3	0,5 mm/m	--	1	8421411013656	

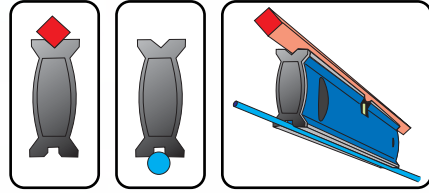

Nivelación de tubos.
Level for pipes.
 Nivellement de tubes.
 Livellazione tubi.

Special levels



Ref.	mm						€
33226	600	1	± 0,25°	--	1	8421411004203	

Nivel goniométrico. Determina inclinaciones y pendientes.
Spirit level. Measures angled surfaces.
 Niveau goniométrique. Détermine les inclinaisons et les pentes.
 Livella goniometrica. Determina inclinazioni e pendenze.

Niveaux spéciaux



Ref.	mm						€
NT-60	600	2	1,5 mm/m	--	1	8421411012659	



Regla-nivel-trazador.
Rule-level-marker.
 Règle-niveau-traceur.
 Riga-livella-tracciatore.

Livelle speciali



Ref.	mm						€
340	85	1	2,5 mm/m	●	1	8421411013465	

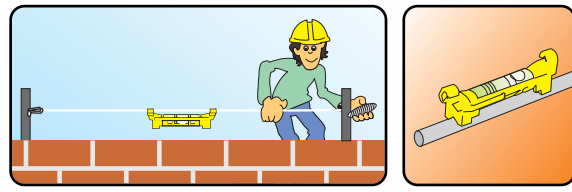

Nivel para cuerda.
Level for cord.
 Niveau pour corde.
 Livella per cavo.



Ref.	mm						€
501	140	3	2,5 mm/m	●	1	8421411013472	

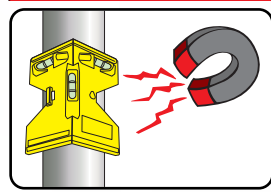

Nivelación de postes.
Level for post.
 Nivellement de poteaux.
 Livellazione pali.

Ref.	mm						€
25030	300	2	1 mm/m	--	1	8421411006344	
25040	400	2	1 mm/m	--	1	8421411006351	
25050	500	2	1 mm/m	--	1	8421411006368	
25060	600	2	1 mm/m	--	1	8421411006375	
25080	800	2	1 mm/m	--	1	8421411006382	
25100	1000	2	1 mm/m	--	1	8421411009635	

BASIC



Ref.	mm						€
15030	300	2	1 mm/m	--	1	8421411009413	
15040	400	2	1 mm/m	--	1	8421411007228	
15050	500	2	1 mm/m	--	1	8421411007235	
15060	600	2	1 mm/m	--	1	8421411007242	

BASIC



Ref.	mm						€
440	100	2	2 mm/m	Caja	25	8421411013670	



Mini-nivel con 2 burbujas.
Pocket level with 2 vials.
 Niveau a poche avec 2 bulles.
Mini-livella con 2 fiale.



Ref.	mm						€
TORPEDO	200	3	2 mm/m	--	1	8421411006672	
TP-300	200	3	2 mm/m	--	1	8421411011027	



Nivel TORPEDO con base magnética.
TORPEDO level with magnetic base.
 Niveau TORPEDO avec base magnetique.
Livella TORPEDO con base magnetica.



Ref.	mm						€
P.22	140	0		Caja	1	8421411006856	

Nivel de agua. Juego de dos tubos graduados. Tipo Vienna.
Water level. Set with two graduated tubes. Vienna type.
 Niveau d'eau. Jeu de 2 tubes gradués. Type Vienna.
Livella ad acqua. Set di due tubi graduati. Tipo Vienna.



Ref.	Forma						€
B-1	Horizontal	0,5 mm/m	--	1	1	8421411009987	
B-2	Circular	0,5 mm/m	--	1	1	8421411009994	
B-3	Horizontal (Ala de avión)	0,5 mm/m	--	1	1	8421411010006	
040	Con llavero	2 mm/m	--	1	1	8421411008201	



Niveles básicos y niveles bricolaje

Basic levels and DIY levels

Niveaux standard et niveaux bricolage

Livelle standard e livelle bricolage



NEW

LÁSER AUTOMÁTICO

AUTOMATIC LASER / LASER AUTOMATIQUE / LASER AUTOMATICA

Ref.					€
5640	0,15 mm/m	Caja	1	8421411005162	

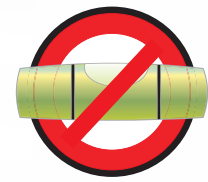
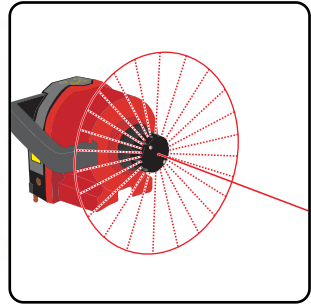

Niveles láser pro line

Laser levels pro line

Niveaux laser pro line

Livelle laser pro line

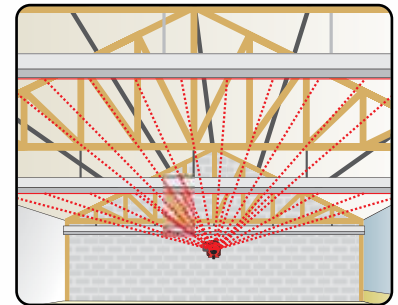
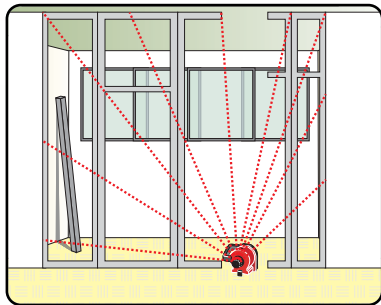
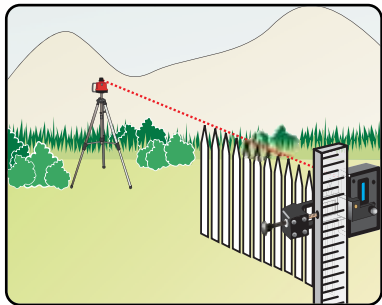

CONTENIDO
- Nivel láser
- Detector control remoto + soporte
- Soporte pared
- Diana
- Gafas
- Maleta

CONTENT
- Level laser
- Detector remote control + support
- Support wall
- Magnetic target
- Laser glasses
- Carrying case

CONTENU
- Niveau laser
- Detecteur tele commande + support
- Mur de soutien
- Diane
- Lunettes
- Valise rampement

SODDISFARE
- Livello laser
- Detectore telecomando + sostegno
- Parete di sostegno
- Mirino
- Occhiali
- Valigetta

ESPECIFICACIONES TÉCNICAS	
Recomendaciones de uso:	300 m Ø con detector.
Precisión nivelación:	0,015% ± 15 mm a 100 m.
Campo de autonivelación:	±10%.
Modo barrido:	Ángulo de 10° a 48°.
Diódo láser:	Versión europea: 1 mW/ Clase II.
Batería:	Recargable.
Vida batería:	40 horas.
Tamaño:	15x16x17 cm.
Velocidad rotación:	60-610 rpm.
Protección:	Contra el agua y el polvo.

TECHNICAL SPECIFICATIONS	
Recommended use:	300 m Ø with detector.
Leveling accuracy:	0,015% ± 15 mm a 100 m.
Levelling range:	±10%.
Scanning mode:	Angle from 10° to 48°.
Laser diode:	European version: 1 mW/ Class II.
Power:	Rechargeable battery.
Battery life:	40 hours.
Size:	15x16x17 cm.
Rotation speed:	60-610 rpm.
Protection:	Rain and dustproof.

CARACTÉRISTIQUES TECHNIQUES	
Recommandations d'usage:	300 m Ø avec détecteur.
Precision de niveau:	0,015% ± 15 mm à 100 m.
Champs d'autonivellement:	±10%.
Mode hut:	Angle de 10° à 48°.
Laser diode:	Versión europea: 1 mW/Clase II.
Batteries:	Rechargeable.
Durée batterie:	40 heures.
Touille:	15x16x17 cm.
Vitesse de rotation:	60-610 rpm.
Protection:	Pluie et poussière.

SPECIFICHE TECNICHE	
Recomandazioni d'uso:	300 m Ø con il rivelatore.
Precisione livella:	0,015% ± 15 mm a 100 m.
Campo di autolivellazione:	±10%.
Modo esame:	Angolo da 10° a 48°.
Diòdo laser:	Versión europea: 1 mW/ Clase II.
Batteria:	Batteria ricaricabile.
Durata batteria:	40 ore.
Misure:	15x16x17 cm.
Velocità di rotazione:	60-610 rpm.
Protezione:	Contro pioggia e polvere.

LÁSER MANUAL

MANUAL LASER / LASER MANUALE / LASER MANUEL

NEW



Ref.					€
5500	0,2 mm/m	Caja	1	8421411005100	

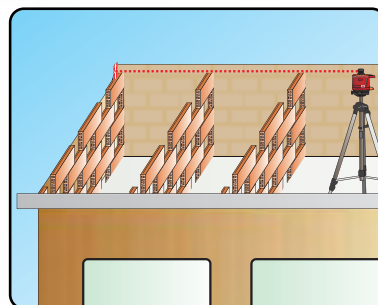
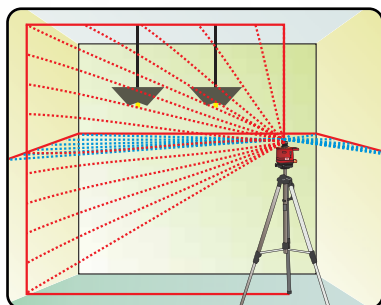
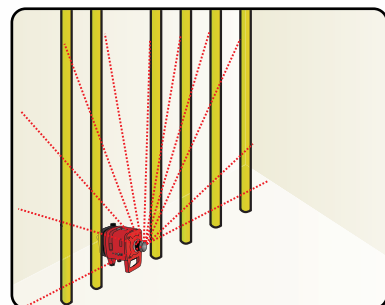
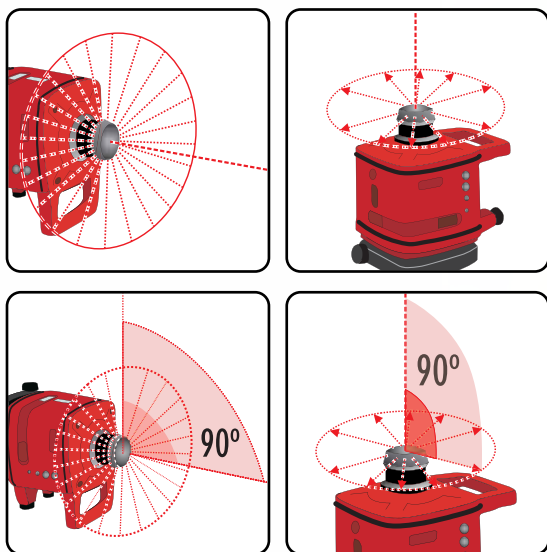

Niveles láser
pro line

Laser levels
pro line

Niveaux laser
pro line

Livelle laser
pro line

CONTENIDO
- Nivel láser
- Detector láser
- Gafas
- Diana
- Pilas
- Instrucciones
- Maleta

CONTENT
- Level laser
- Laser detector
- Laser glasses
- Magnetic target
- Batteries
- Operating manual
- Carrying case

CONTENUTO
- Niveau laser
- Detecteur
- Lunettes
- Diane
- Piles
- Instructions
- Valise rangement

SODDISFARE
- Livello laser
- Detectore
- Occhiali
- Mirino
- Batterie
- Manuale
- Valigetta

ESPECIFICACIONES TÉCNICAS	
Precisión	±2 mm a 10 m.
Rango de trabajo:	Interior: 30 m./en barrido 50 m. Exterior: 150 m. con detector láser.
Diodo láser:	635 nm.
Clasificación:	Clase II a.
Velocidad rotación:	Variable en pasos: 0-150 rpm.
Cobertura rotación:	360°.
Modo barrido:	Ángulos: 15°/30°.
Método nivelación:	Manual.
Pilas:	4 pilas alcalinas.
Vida batería:	18 horas.
Peso:	1,8 Kg.

CARACTERISTIQUES TECHNIQUES	
Precision:	±2 mm à 10 m.
Recommandations d'usage:	Intérieur: 30 m./mode huit 50 m. Extérieur: 150 m. avec détecteur laser.
Laser diode:	635 nm.
Classification:	Classe II a.
Vitesse de rotation:	Variable étapes: 0-150 rpm.
Assurance de rotation:	360°.
Mode de balayage:	Angles: 15°/30°.
Méthode de nivellement:	Manuel.
Piles:	4 piles alcalines.
Durée batterie:	18 h.
Poids:	1,8 Kg.

TECHNICAL SPECIFICATIONS	
Accuracy:	±2 mm to 10 m.
Recommended working range:	Indoor: 30 m./scan mode 50 m. Outdoor: 150 m. with laser detector
Laser diode:	635 nm.
Classification:	Class II a
Rotation speed:	Variable in steps: 0-150 rpm
Rotational coverage:	360°.
Scan mode:	Angles: 15°/30°.
Levelling method:	Manual
Battery:	4 alkaline batteries
Battery life:	18 hours.
Weith:	1,8 Kg.

SPECIFICHE TECNICHE	
Precisione:	±2 mm a 10 m.
Raggio angolazione:	Int.: 30 m./modo esplorazione 50 m. Ext.: 150 m. con detectore laser.
Diodo laser:	635 nm.
Classificazione:	Classe II a.
Velocità di rotazione:	Variabile ai punti: 0-150 rpm.
Rotazione:	360°.
Modo esame:	Angoli: 15°/30°.
Metodo livellamento:	Manuale.
Batterie:	4 batterie alcaline.
Autonomia:	18 ore.
Peso:	1,8 Kg.



NEW



CROSS LINE

CROSS LINE / CROSS LINE / CROSS LINE

Ref.					€
5100	0,33 mm/m	Caja	1	8421411005070	

Láser automático que proyecta una cruz y una línea de referencia vertical a 90°.
Automatic laser that projects a cross and a plumb line a 90°.
Laser automatique qui projette une croix très visible, ainsi qu'une ligne de référence verticale à 90°.
Laser automatica che proietta una croce e una linea verticale a 90°.

Niveles láser
pro line

Laser levels
pro line

Niveaux laser
pro line

Livelle laser
pro line

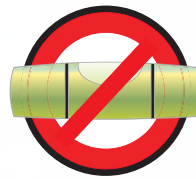
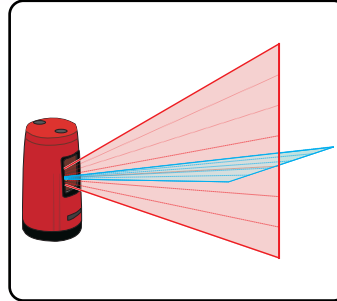

CONTENIDO	CONTENT
- Nivel láser	- Laser level
- Gafas	- Laser glasses
- Soporte	- Support
- Diana	- Magnetic target
- Bolsa	- Bag



CONTENUTO	SODDISFARE
- Niveau laser	- Livella laser
- Lunettes	- Occhiali
- Support	- Supporto
- Diane	- Mirino
- Sac	- Valigetta

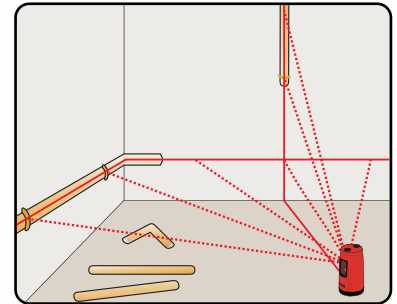
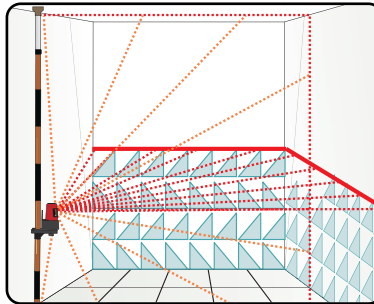
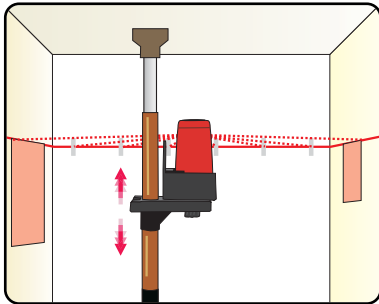

ESPECIFICACIONES TÉCNICAS	
Precisión:	±3 mm/9 m.
Línea Horizontal/Vertical (punta a punta):	=1,5 mm a 3 m.
Longitud de la línea:	10 m a 14 m.
Rango de trabajo:	10 m dependiendo de la iluminación del área de trabajo.
Diodo láser:	635 nm horizontal y vertical.
Rango de autonivelación:	±2,5°.
Velocidad de autonivelación:	≤3 segundos.
Batería:	3x AA pilas alcalinas.
Vida batería:	15 horas continuas a 20°C.
Peso:	0,9 Kg con estuche.

TECHNICAL SPECIFICATIONS	
Accuracy:	±3 mm/9 m.
Horizontal/Vertical line (end to end):	=1,5 mm at 3 m.
Line length:	10 m to 14 m.
Working range:	Up to 10 m, dependent upon illumination or work area.
Laser diode:	635 nm horizontal and vertical.
Self-leveling range:	±2,5°.
Self-leveling speed:	≤3 seconds.
Power:	3x AA alkaline batteries.
Battery life:	Continuous use 15 hour at 20°C.
Weight:	0,9 Kg with carrying case.

CARACTERISTIQUES TECHNIQUES	
Precision:	±3 mm/9 m.
Ligne horizontale/verticale (fin à l'extrémité):	=1,5 mm a 3 m.
Ligne length:	10 m à 14 m.
Gamme fonctionnante:	Jusqu'à 10m, dépendants sur secteur d'élimination ou de travail.
Laser diode:	635 nm horizontale e verticale.
Champs d'autonivellement:	±2,5°.
Vitesse de rotation:	≤3 secondes.
Piles:	3x AA piles alcalines.
Durée batterie:	15 heures continues à 20°C.
Poids:	0,9 Kg avec sac.

SPECIFICHE TECNICHE	
Precisione:	±3 mm/9 m.
Linea orizzontale/verticale (all'estremita):	=1,5 mm a 3 m.
Linea length:	10 m a 14 m.
Zona di lavoro:	Fino ai 10m, dipendenti su zona di lavoro o di illuminazione.
Diodo laser:	635 nm orizzontale e verticale.
Campo di autolivellazione:	±2,5°.
Velocità di autolivellazione:	≤3 secondi.
Batterie:	3x AA batterie alcalini.
Autonomia:	Uso continue 15 ore a 20°C.
Peso:	0,9 Kg con caso trasportante.

POCKET LÁSER

POCKET LASER / POCKET LASER / POCKET LASER

Ref.					€
5300	0,3 mm/m	Caja	1	8421411005087	

Láser automático que proyecta una línea horizontal o vertical o una cruz.

Automatic laser that projects an horizontal line or vertical or a cross.

Laser automatique qui projette une ligne horizontale, puis une ligne verticale puis une croix.

Laser automatica che proietta una linea orizzontale o verticale o una croce.

NEW

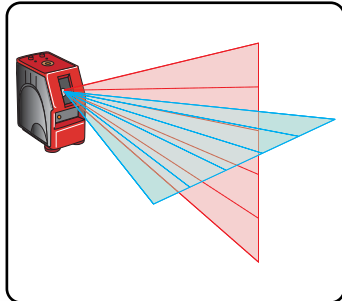

CONTENIDO	CONTENT
- Nivel láser	- Laser level
- Gafas	- Laser glasses
- Soporte	- Support
- Diana	- Magnetic target
- Bolsa	- Bag



CONTENUTO	SODDISFARE
- Niveau laser	- Livella laser
- Lunettes	- Occhiali
- Support	- Supporto
- Diane	- Mirino
- Sac	- Valigetta

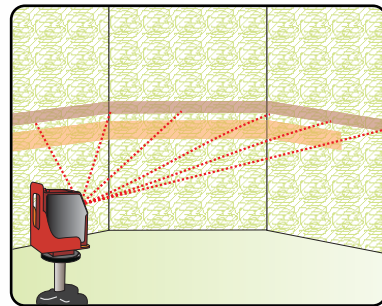
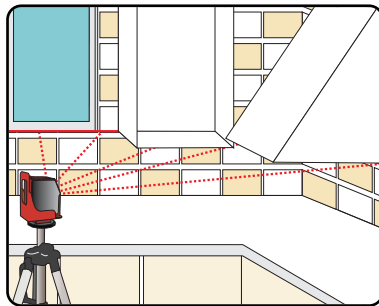
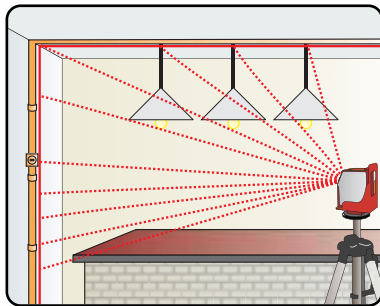
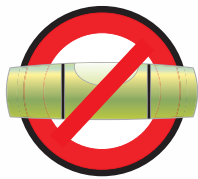

CARACTERÍSTICAS	
Compensador magnético que asegura un tiempo de autonivelación más rápido. La línea horizontal/vertical se extiende desde la pared hasta el techo. Sistema de fijación incorporado para trabar el compensador y así evitar la vibración durante el transporte.	
CARACTERÍSTICAS TÉCNICAS	
Diodo láser:	2x 635 nm.
Clase láser:	Clase II, < 1 mw o clase IIIa, < 1 mw < 5 mw.
Precisión:	Nivel ± 1,5 mm a 5 m línea Horizontal/Vertical ± 1,5 mm a 5 m.
Rango de autonivelación:	±3°.
Incluye:	2x AA pilas alcalinas.
Duración:	> 10 horas continuas.
Peso:	200 gr.

FEATURES	
Magnetic damping compensator to ensure more quick self-leveling time. Horizontal/vertical/laser line, vertical line will be extended across ceiling. Built-in locking system to lock the compensator when in transportation to avoid vibration.	
TECHNICAL SPECIFICATIONS	
Laser diode:	2x 635 nm.
Laser safety class:	Class II, < 1 mw or class IIIa, < 1 mw < 5 mw.
Accuracy:	Leveling ± 1,5 mm at 5 m Horizontal/Vertical line ± 1,5 mm at 5 m.
Self-leveling range:	±3°.
Power supply:	2x AA alkaline batteries.
Operating time:	> 10 continuous hours.
Weight:	200 gr.

CARATTERISTICQUES	
Compensateur de atténuation magnétique à assurer un temps self-leveling plus rapide. La ligne horizontale/verticale/laser, ligne verticale sera prolongée à travers le plafond. Système de fermeture intégré pour fermer à clef compensateur quand dans le transport à éviter la vibration.	
CARATTERISTICQUES TECHNIQUES	
Laser diode:	2x 635 nm.
Classe de safety de laser:	Classe II, < 1 mw ou classe IIIa, < 1 mw < 5 mw.
Precision:	Nivelant le ± 1.5 mm à 5 m ligne horizontale/verticale ± 1,5 mm à 5 m.
Gamme Self-leveling:	±3°.
It comprises:	2x AA piles alkaline.
Durée batterie:	> 10 heures continues.
Poids:	200 gr.

CARATTERISTICHE	
Compensatore inumiditenti magnetico a accertare il tempo self-leveling più rapido. La linea verticale/orizzontale/laser, linea verticale sarà estesa attraverso il soffitto. Sistema di bloccaggio incorporato per bloccare il compensatore quando in trasporto da evitare vibrazione.	
SPECIFICHE TECNICHE	
Diodo laser:	2x 635 nm.
Classe laser:	Classe II, < 1 mw o classe IIIa, < 1 mw < 5 mw.
Precisione:	Livellando ± 1,5 mm a 5m Linea orizzontale/verticale ± 1,5 mm a 5 m.
Autolivellamento:	±3°.
Comprende:	2x AA batterie alcalini.
Durata:	> 10 ore continue.
Peso:	200 gr.

Niveles láser
pro line

Laser levels
pro line

Niveaux laser
pro line

Livelle laser
pro line

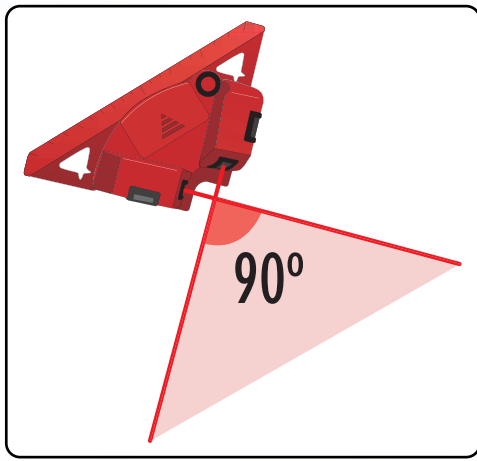

ESCUADRA LÁSER 90°

LASER SQUARE 90° / EQUERRE LASER 90° / SQUADRA LASER 90°

Ref.					€
5101	0,3 mm/m	Caja	1	8421411005063	

Escuadra láser idónea para decoración, carpintería, pavimentación, embaldosado...

Laser square for decoration, carpentry, paving, tiled...

Equerre laser idéal pour la décoration, menuiserie, pavant, carrelé...

Squadra laser ideale per decorazione, carpenteria, pavimenti, coperto di tegoli...

NEW

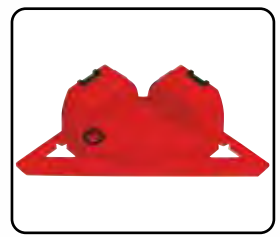
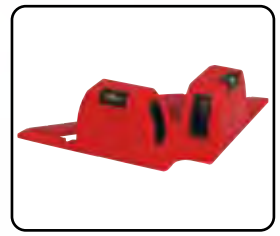

CONTENIDO
- Nivel láser - Bolsa

CONTENT
- Laser level - Bag

CONTENU
- Niveau laser - Sac

SODDISFARE
- Livella laser - Borsa

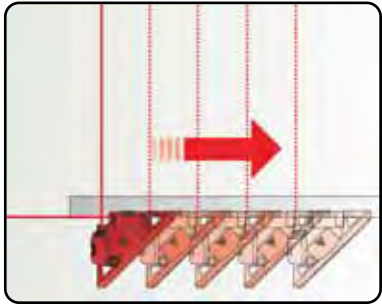
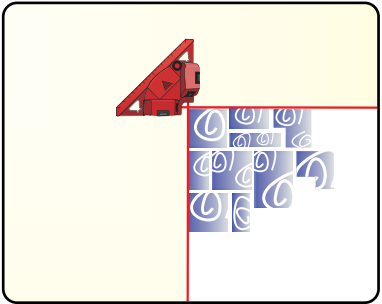

ESPECIFICACIONES TÉCNICAS	
Precisión:	±3 mm / 10 m.
Rango:	Máx. 30 m.
Diodo láser:	2x 635 nm, 5mw.
Clase láser:	Class IIa.
Incluye:	2 x1,5v.AA pilas alcalinas.
Duración:	48 h.
* Dependiendo de la iluminación de la habitación.	

TECHNICAL SPECIFICATIONS	
Accuracy:	±3 mm / 10 m.
Working range:	Max. 30 m.
Laser source:	2x 635 nm, 5mw.
Laser class:	Class IIa.
Power supply:	2 x1,5v.AA alkaline batteries.
Operating time:	48 h.
* Depending on room illumination.	

Niveles láser
pro line

Laser levels
pro line

Niveaux laser
pro line

Livelle laser
pro line

CARATTERISTICHE TECNICHE	
Precision:	±3 mm / 10 m.
Gamma funzionante:	Max. 30 m.
Diode laser:	2x 635 nm, 5mw.
Classe di safety de laser:	Classe IIa.
It comprises:	2x1,5v.AA piles alkaline.
Durée batterie:	48 h.
* Selon l'illumination de pièce	

SPECIFICHE TECNICHE	
Precisione:	±3 mm / 10 m.
Gamma di funzionamento:	Max. 30 m.
Diodo laser:	2x 635 nm, 5mw.
Classe laser:	Classe IIa.
Comprende:	2x 1,5v.AA batterie alcalini.
Durata:	48 h.
* Secondo illuminazione della stanza.	

LÁSER AUTOMÁTICO 5 PUNTOS

AUTOMATIC LASER 5 POINTS / LASER AUTOMATIQUE 5 POINTS / LASER AUTOMATICA 5 PUNTI

Ref.					€
5400	0,4 mm/m	Caja	1	8421411016039	

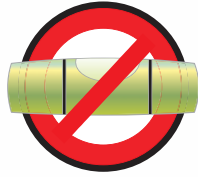
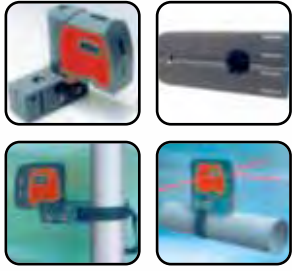

NEW



ESPECIFICACIONES TÉCNICAS	
Precisión de nivelación:	±0,4 mm/m.
Campo de nivelación:	±10°.
Alcance:	30 m.
Diodo láser:	635 nm, Clase II.
Dimensiones:	11,5 x 10 x 3,8.
Batería:	3 pilas R6.
Peso:	250 gr.

TECHNICAL SPECIFICATIONS	
Levelling accuracy:	±0,4 mm/m.
Levelling range:	±10°.
Reaches:	30 m.
Diode laser:	635 nm, Class II.
Dimensions:	11,5 x 10 x 3,8.
Battery:	3 batteries R6.
Weight:	250 gr.

CARACTÉRISTIQUES TECHNIQUES	
Precisión de nivellement:	±0,4 mm/m.
Champs d'autonivellement:	±10°.
Extensions:	30 m.
Diode laser:	635 nm, Classe II.
Dimensions:	11,5 x 10 x 3,8.
Batterie:	3 piles R6.
Poids:	250 gr.

SPECIFICHE TECHNIQUE	
Precisione di livellazione:	±0,4 mm/m.
Campo di autolivellazione:	±10°.
Estensioni:	30 m.
Diode laser:	635 nm, Classe II.
Dimensioni:	11,5 x 10 x 3,8.
Batteria:	3 batteries R6.
Peso:	250 gr.

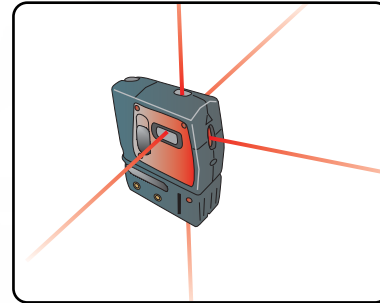

Niveles láser
pro line

Laser levels
pro line

PUNTAL GRADUADO

GRADUATED PROP / APPUI VERTICAL GRADUÉ / SUPPORTO GRADUATO

Ref.					€
5515	Máx. 360 cm	Caja	1	8421411005155	

CONTENIDO
- Cinco secciones + una sección telescópica. - Soporte. - Punta graduada. - Bolsa.

CONTENT
- Five sections + a section by telescope. - Support. - Graduated end. - Bag.

CONTENU
- Cinq sections + section telescopique. - Appui. - Pointe graduée. - Sac.

SODDISFARE
- Cinque sezioni + 1 sezione telescopica. - Supporto. - Punta graduata. - Borsa.

NEW



Niveaux laser
pro line

Livelle laser
pro line

MIRA TELESCÓPICA

TOPOGRAPHIC STAKE / CANNE TÉLESCOPIQUE / MISURE TELESCOPIQUE

Ref.	Min.	Max.					€
314500	1,25 m	5 m	1,7 Kg.	Caja	1	8421411002766	





NEW



TRÍPODE ----- TRIPOD / TRÉPIED / CAVALLETTO

Ref.	Kg	Caja	1	8 421411 000007	€
5310	1,5 Kg	Caja	1	8421411015094	



Niveles láser
pro line

Laser levels
pro line

Niveaux laser
pro line

Livelle laser
pro line

NEW



TRÍPODE ALTO ----- HIGH TRIPOD / HAUT TRÉPIED / CAVALLETTO SUPERIORE

Ref.	Kg	Caja	1	8 421411 000007	€
5610	8,5 Kg	Caja	1	8421411005179	



NEW



DIANA LÁSER ----- LASER TARGET / DIANE LASER / MIRINO LASER

Ref.	Medidas	Caja	1	8 421411 000007	€
5501	150x75 mm	Caja	1	8421411005124	

NEW



GAFAS LÁSER ----- LASER GLASS / LUNETTES LASER / OCCHIALI LASER

Ref.	Caja	1	8 421411 000007	€
5505	Caja	1	8421411005131	

NEW



DETECTOR LÁSER ----- DETECTOR LASER / LASER DÉTECTEUR / DETECTORE LASER

Ref.	Caja	1	8 421411 000007	€
5506	Caja	1	8421411005117	

NEW



SOPORTE ----- SUPPORT / APPUI / SUPPORTI

Ref.	Caja	1	8 421411 000007	€
5510	Caja	1	8421411005148	

Ref.	mm					€
3014	400	3	Maleta	1	8421411009956	

Alcance 25 m. Proyecta 1 punto, 1 línea horizontal, 1 línea vertical y 1 cruz.

Range 25 m. Projects mark, horizontal line, vertical line and a cross.

Portée 25 m. Projette 1 point, 1 ligne horizontale, 1 ligne verticale et 1 croix.

Portata 25 m. Proietta un punti, una linea orizzontale, una linea verticale e una croce.

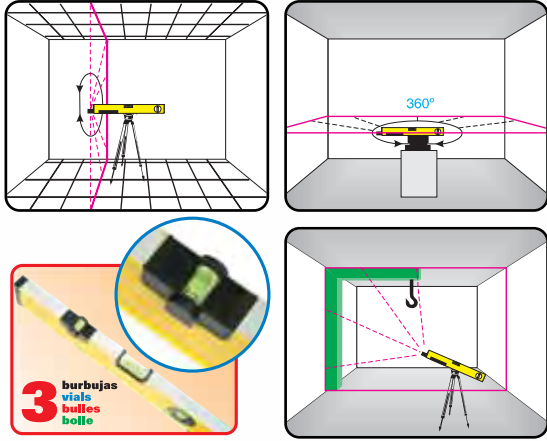

Niveles láser
basic line

Ref.	mm					€
3045	170	3	--	1	8421411013960	

Nivel Torpedo láser con base.

Laser Torpedo level with base.

Niveau Torpedo laser avec bse.

Livella Torpedo laser con base.

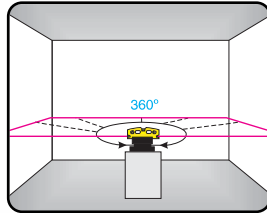

Laser levels
basic line

Niveaux laser
basic line

Ref.	Rango	Altura				€
3013	30 cm	42-87 cm	--	1	8421411013953	

Tripode de aluminio.

Aluminium tripod.

Trépied en aluminium.

Trepiedi in alluminio.



Livelle laser
basic line





Niveles láser
basic line

Laser levels
basic line

Niveaux laser
basic line

Livelle laser
basic line



Ref.	Alcance					€
3010	30 m	3	Maleta	1	8421411012338	

Nivel láser rotatorio que proyecta 1 línea horizontal y 1 punto vertical.
Rotatory laser level that projects an horizontal line and a vertical mark.
 Niveau laser rotatoire qui projette une ligne horizontale et un point verticale.
 Livella laser rotatoria che proietta una linea orizzontale e un punto verticale.

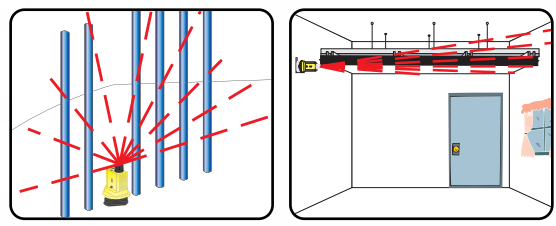

Ref.	Alcance					€
3020	10 m	2	Maleta	1	8421411013663	

Nivel láser autonivelante con 2 ventanas que proyecta una cruz y una línea a 90°.
 Autonivelante si está a $\pm 6^\circ$.
Self-levelling laser level with 2 windows that projects a cross and a line at 90°.
 Self-levels if it is $\pm 6^\circ$.
 Niveau laser autonivelant avec 2 fenêtres qui projette une croix et une ligne à 90°.
 Autonivelle si est $\pm 6^\circ$.
 Livella laser autolivellante con 2 finestre che proietta una croce e una linea a 90°.
 Autolivella se e $\pm 6^\circ$.

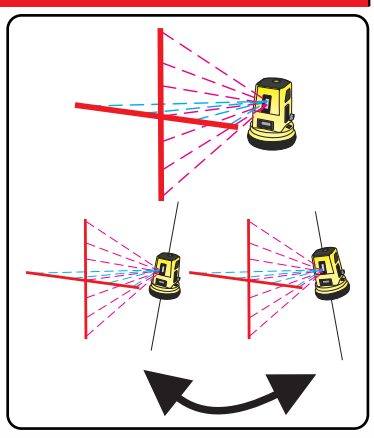

Ref.	Alcance					€
6360	30 m	3	•	1	8421411 000007	8421411014950

Escuadra láser 45° - 90°.

Square laser 45° - 90°.

Equerre laser 45° - 90°.

Squadra laser 45° - 90°.

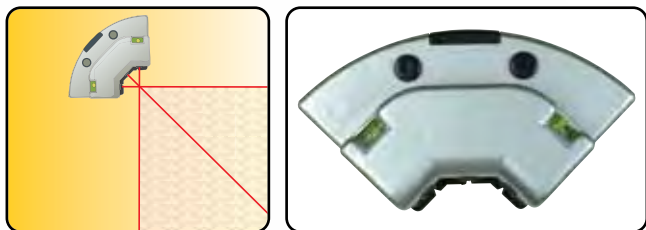

NEW



Niveles láser
basic line

Laser levels
basic line

Niveaux laser
basic line

Livelle laser
basic line

Ref.	Alcance					€
1010	5 m	2	•	1	8421411 000007	8421411014417

Flexómetro (5m x 25mm) trazador láser con base giratoria.

Laser tracer measuring tape (5m x 25mm) with rotatory base.

Mètre à ruban (5m x 25mm) traceur laser avec base rotatoire.

Flessometro (5m x 25mm) tracciatore laser con base giratoria.

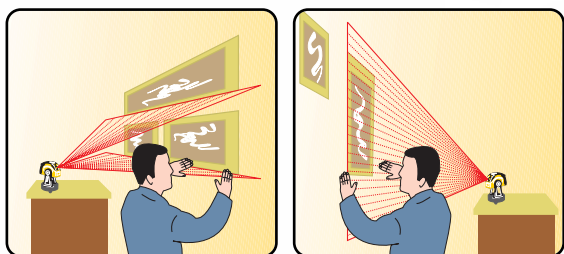

Escuadras

Squares

Equerres

Squadre



Ref.	mm						€
498035	350	2	0,15°	Caja	1	8421411009970	

Escuadra aluminio digital. Capacidad 0-185°.

Digital analogical square. Range 0-185°.

Equerre en aluminium digitale. Capacité 0-185°.

Squadra di alluminio digitale. Capacità 0-185°.

DIGITAL

Ref.	mm						€
480000	480	2	±0,5 mm/m	Caja	1	8421411012314	

Escuadra aluminio analógica. Capacidad 0-220°.

Aluminium analogical square. Range 0-220°.

Equerre en aluminium analogique. Capacité 0-220°.

Squadra di alluminio analogica. Capacità 0-220°.

Ref.	mm				€
2048	200	--	1	8421411005729	
2049	250	--	1	8421411005736	
2050	300	--	1	8421411003671	
2051	400	--	1	8421411003688	

Escuadra profesional de acero inoxidable y talonera de aluminio rectificado. Números grabados.

Stainless steel professional square and calibrated aluminium back. Engraved numbers.

Equerre professionnel en acier inoxydable et talon en aluminium rectifié. Numéros gravés.

Squadra professionale in acciaio inossidabile e base in alluminio, tutta rettificata. Numerazione incisa.

Ref.	mm				€
5040	400	--	1	8421411013700	
5050	500	--	1	8421411013717	

Escuadra profesional de aluminio biselada.

Bevelled aluminium professional square.

Equerre professionnel taillée en aluminium.

Squadra professionale smussata in alluminio.

Ref.	mm				€
4030	300	--	1	8421411013724	

Escuadra ajustable de aluminio.

Adjustable aluminium square.

Equerre réglable en aluminium.

Squadra regolabile in alluminio.

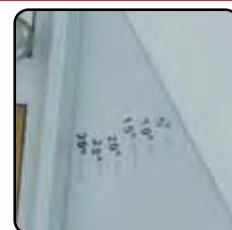

Ref.	mm				€
930	300	●	1	8421411014189	

Escuadra ajustable 45° 90° 135° de aluminio.

Adjustable 45° 90° 135° aluminium square.

Equerre réglable 45° 90° 135° en aluminium.

Squadra regolabile 45° 90° 135° in alluminio.

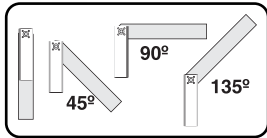

Ref.	mm				€
222	300 x 180	--	1	8421411013236	

Escuadra con talonera.

Square with back.

Equerre avec talon.

Squadra con base.



Ref.	mm				€
1049	250	--	1	8421411006634	
1050	300	--	1	8421411006641	
ESY-250	250	--	1	8421411011072	
ESY-300	300	--	1	8421411011089	

Escuadra bricolage metálica.

DIY metal square.

Equerre bricolage métallique.

Squadra metallica bricolage.

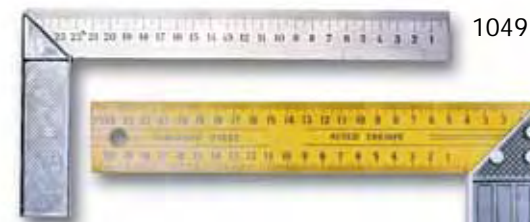

1049

ESY-250

Ref.	mm				€
3048	250	--	1	8421411006665	
3061	250	--	1	8421411011386	

Escuadra ajustable de acero y acero-madera.

Adjustable steel and steel-wood square.

Equerre réglable en acier et acier-bois.

Squadra regolabile in acciaio e in acciaio-legno.



3048

3061

Ref.	mm				€
6040	165 x 320	--	1	8421411014394	

Escuadra de aluminio buscadora de ángulos, interiores de 5°-85° y exteriores de 10°-170°.

Adjustable aluminium square inside 5°-85° and outside 10°-170°.

Equerre réglable en aluminium, intérieurs de 5°-85° et extérieurs de 10°-170°.

Squadra in alluminio rilevatore di angoli, interni di 5°-85° e esterni di 10°-170°.

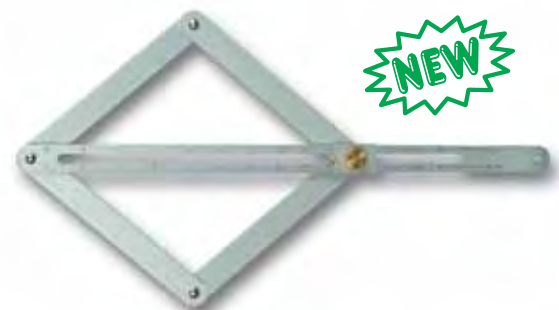
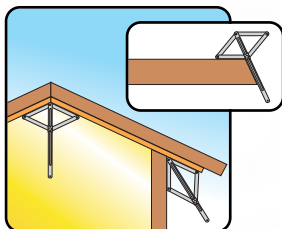

NEW

Ref.	mm				€
3600	595 x 840	--	1	8421411014387	

Cartabón plegable de aluminio.

Aluminium folding square.

Equerre pliante en aluminium.

Squadra pieghevole in alluminio.



NEW

Escuadras

Squares

Equerres

Squadre



Ref.	mm						€
1040	400	35 mm	1	--	1	8421411014349	
1060	600	50 mm	1	--	1	8421411014356	

Regla de aluminio.

Aluminium rule.

Règle en aluminium.

Righello in alluminio.

Top Quality



Ref.	mm						€
1056-01	300	30 mm	0,8 mm	2	--	1	8421411001240
1056-02	500	30 mm	0,8 mm	2	--	1	8421411001257
1056-03	1000	30 mm	0,8 mm	2	--	1	8421411001264
1056-04	1500	30 mm	0,8 mm	2	--	1	8421411001271
1056-05	2000	30 mm	0,8 mm	2	--	1	8421411001288
1056-06	3000	30 mm	0,8 mm	2	--	1	8421411001295
1056-08	5000	30 mm	0,8 mm	2	--	1	8421411001301

Regla semirígida mate.

Semi-flexible rule with satin chrome finishing.

Règle semirigide mate.

Righello semirigido opaco.



Ref.	mm						€
1511	150	18 mm	0,7 mm	1	--	1	8421411008720
3011	300	25 mm	0,8 mm	1	--	1	8421411008737
5011	500	27 mm	0,8 mm	1	--	1	8421411008744

Regla semirígida mate.

Semi-flexible rule with satin chrome finishing.

Règle semirigide mate.

Righello semirigido opaco.



Ref.	mm						€
1051-02	150	13 mm	0,5 mm	2	--	1	8421411001165
1051-03	200	13 mm	0,5 mm	2	--	1	8421411001172
1051-04	250	13 mm	0,5 mm	2	--	1	8421411001189
1051-05	300	13 mm	0,5 mm	2	--	1	8421411001196
1051-06	500	20 mm	0,5 mm	2	--	1	8421411001202
1051-07	1000	25 mm	0,5 mm	2	--	1	8421411001219
1051-08	1500	25 mm	0,5 mm	2	--	1	8421411001226
1051-09	2000	25 mm	0,5 mm	2	--	1	8421411001233

Regla flexible mate.

Flexible rule with satin chrome finishing.

Règle souple mate.

Righello flessibile opaco.



Ref.	mm						€
1509	150	13 mm	0,5 mm	1	--	1	8421411013304
3009	300	13 mm	0,5 mm	1	--	1	8421411013311
5009	500	20 mm	0,5 mm	1	--	1	8421411013328

Regla flexible mate.

Flexible rule with satin chrome finishing.

Règle souple mate.

Righello flessibile opaco.

Reglas

Rules

Règles

Righelli

Ref.	m	n°					€
4040	2	10		Caja	10	8421411011317	
3040	2	10		Caja	10	8421411011133	
2040	2	10		Caja	6	8421411011096	

Metros plegables de madera.

Wooden folding rules.

Mètres pliants en bois.

Metri pieghevoli in legno.

Ref.	m	n°					€
2000	2	10		Caja	10	8421411003602	
2003	1	10		Caja	10	8421411009000	

Metros plegables de fibra de vidrio.

Fiberglass folding rules.

Mètres pliants en fibre de verre.

Metri pieghevoli in fibra di vetro.

Ref.	m	n°					€
2012	2	10		--	10	8421411014523	

Metro plegable de fibra de vidrio.

Fiberglass folding rule.

Mètre pliant en fibre de verre.

Metri pieghevole in fibra di vetro.

Top Quality

Ref.	m	n°					€
2022	2	10		--	10	8421411014530	

Metro plegable de fibra de vidrio.

Fiberglass folding rule.

Mètre pliant en fibre de verre.

Metri pieghevole in fibra di vetro.

Top Quality

Ref.	m	n°					€
2001	2	10		Caja	6	8421411006221	
2005	2	10		Caja	6	8421411003626	
2007	2	10		Caja	6	8421411003640	
2009	1	5		Caja	12	8421411003657	

Metros plegables de madera.

Wooden folding rules.

Mètres pliants en bois.

Metri pieghevoli in legno.

Top Quality

4040



3040



2040

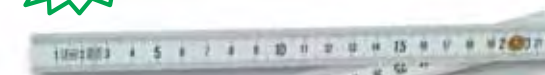

**Metros plegables
y cintas para sastrer**

**Folding rules and
tailoring tapes**

**Mètres pliants et
mesures couturières**

**Metri pieghevoli e
misura per sartù**

**Metros plegables
y cintas para sastre**

**Folding rules and
tailoring tapes**

**Mètres pliants et
mesures couturières**

**Metri pieghevoli e
misure per sarti**



Ref.	m	n°					€
3001	2	10		Caja	6	8421411011140	
3005	2	10		Caja	6	8421411011157	
3007	2	10		Caja	6	8421411011164	
3041	2	10		Caja	10	8421411012345	

Metros plegables de madera para publicidad.

Wooden folding rules for advertisement.

Mètres pliants en bois pour la publicité.

Metri pieghevoli in legno per pubblicità.

Ref.	m	n°					€
2002	2	10		--	10	8421411013229	

Metro plegable de aluminio.

Aluminium folding rule.

Mètre pliant en aluminium.

Metro pieghevole in alluminio.

Ref.	m						€
169	1,5	20 mm	0,6 mm	Caja	12	8421411035781	
184	1,5	20 mm	0,7 mm	Caja	12	8421411045798	
184P	1,5	20 mm	0,7 mm	Caja	300	8421411045798	
193	1,5	20 mm	0,9 mm	Caja	12	8421411055804	
373-E	1,5	20 mm	0,9 mm	Caja	12	8421411065811	

Cintas de sastre.

Tailoring tapes.

Mesures couturières.

Nastri per sarti.

Ref.	m						€
218	2	13 mm		Caja	1	8421411011102	
318	3	13 mm		Caja	1	8421411011119	
1018	10	13 mm		Caja	1	8421411011126	

Cintas metálicas planas. Autoadhesivas.

Steel flat tapes. Self-adhesive.

Rubans plats métalliques. Auto-adhésif.

Nastro piatto in acciaio. Autoadesivo.

Ref.	m						€
2100	1	25x20 mm		--	1	8421411003695	

Vara de madera.

Wooden rule.

Mètre drapier.

Metro da banco in legno.

Ref.			mm				€
N2350	0,05 mm	300 mm	410	●	1	8421411008065	
N2220	0,05 mm	200 mm	290	●	1	8421411003749	
N2217	0,05 mm	150 mm	230	●	1	8421411003732	

Calibre de acero inoxidable cromado mate con freno pulsante.
Stainless steel caliper satin chrome finishing with push lock.
 Pied à coulisse en acier inoxydable chromé mat avec frein à poussoir.
Calibro in acciaio inossidabile cromato opaco con freno a pulsante.



Ref.			mm				€
N2350T	0,05 mm	300 mm	410	●	1	8421411013212	
N2220T	0,05 mm	200 mm	290	●	1	8421411013205	
N2217T	0,05 mm	150 mm	230	●	1	8421411013199	

Calibre de acero inoxidable cromado mate con tornillo prisionero.
Stainless steel caliper satin chrome finishing with set screw lock.
 Pied à coulisse en acier inoxydable chromé mat avec blocage a vis.
Calibro in acciaio inossidabile cromato opaco con vite di fermo.



Ref.			mm				€
2117	0,05 mm	135 mm	210	●	1	8421411003718	

Calibre de acero inoxidable cromado pulido con freno pulsante.
Stainless steel caliper polished chrome finishing with push lock.
 Pied à coulisse en acier inoxydable chromé poli avec frein à poussoir.
Calibro in acciaio inossidabile cromato lucido con freno a pulsante.

Ref.			mm				€
2017K	0,05 mm	130 mm	192	●	1	8421411003664	

Calibre de acero inoxidable cromado pulido con tornillo prisionero.
Stainless steel caliper polished chrome finishing with set screw lock.
 Pied à coulisse en acier inoxydable chromé poli avec blocage a vis.
Calibro in acciaio inossidabile cromato lucido con vite di fermo.

Ref.			mm				€
2016	0,05 mm	150 mm	230	●	1	8421411010914	

Calibre de acero al carbono mate antireflectante con freno pulsante.
Carbon steel caliper satin chrome finishing with push lock.
 Pied à coulisse en acier carbone chromé mat avec frein à poussoir.
Calibro in acciaio al carbonio cromato opaco con freno a pulsante.



Ref.			mm				€
2015	0,05 mm	150 mm	230	●	1	8421411013182	

Calibre de acero al carbono mate antireflectante con tornillo prisionero.
Carbon steel caliper satin chrome finishing with set screw lock.
 Pied à coulisse en acier carbone chromé mat avec blocage à vis.
Calibro in acciaio al carbonio cromato opaco con vite di fermo.



MONOBLOCK



MONOBLOCK



Calibres

Calipers

Pieds à coulisse

Calibri

MONOBLOCK



Ref.							€
AZC-40	0,02 mm	200 mm	65 mm	●	1	8421411000526	

Calibre de tornero.

Vernier caliper.

Pied à coulisse de tourneur.

Calibro per torni.

NEW

MONOBLOCK



Ref.			mm				€
C58/2	0,02 mm	200 mm	200	●	1	8421411015568	
C58/3	0,02 mm	300 mm	300	●	1	8421411015575	

Calibre de profundidad.

Dept gauge.

Pied à coulisse pour profondeur.

Calibro di profondità.

NEW

MONOBLOCK



Ref.			mm				€
CT 200	0,1 mm	200 mm	200	●	1	8421411015643	

Calibre para trazar + una punta widia.

Marking caliper + one widia point.

Pied à coulisse pour tracer + une pointe widia.

Calibro tracciatore + una punta widia.

Ref.			mm				€
1820	0,1 mm	100 mm	115	--	1	8421411008713	

Calibre de latón.

Brass pocket caliper.

Pied à coulisse en laitón.

Calibro in ottone.

Ref.							€
491	0,02 mm	150 mm	40 mm	Caja	1	8421411001967	

Calibre de precisión con cuadrante.

Vernier caliper with dial indicator.

Pied à coulisse à cadran précision.

Calibro di precisione con quadrante.

1910

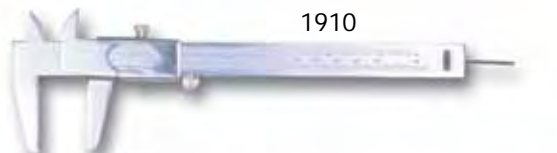

1815



Ref.			mm				€
1910	0,1 mm	150 mm	220	Skin	1	8421411006993	
1815	--	115 mm	210	Skin	1	8421411006658	

Ref. 1910: Metálico. Ref. 1815: Plástico PVC

Ref. 1910: Metal. Ref 1815: PVC plastic.

Ref. 1910: Metallique. Ref. 1815: Plastique PVC.

Ref. 1910: Metalico. Ref. 1815: Plastica PVC.

Ref.							€
CDIN	0,03 mm	150 mm	40 mm	Caja	1	8421411015582	

DIGITAL
INOX

Calibre de acero inoxidable.
Stainless steel caliper.
Pied à coulisse en acier inoxydable.
Calibro in acciaio inossidabile.

NEW



Ref.							€
CDP	0,01 mm	150 mm	40 mm	Caja	1	8421411015599	

DIGITAL

Calibre digital profesional.
Professional digital caliper.
Pied à coulisse digital professionnel.
Calibro digitale professionale.

NEW



Ref.							€
CDE	0,01 mm	150 mm	40 mm	Caja	1	8421411001899	

DIGITAL



Ref.							€
M 100	0,01 mm	0-25 mm	6,5 mm	Caja	1	8421411001004	
M 100	0,01 mm	25-50 mm	6,5 mm	Caja	1	8421411001011	
M 100	0,01 mm	50-75 mm	6,5 mm	Caja	1	8421411001028	
M 100	0,01 mm	75-100 mm	6,5 mm	Caja	1	8421411001035	

Micrómetro exteriores.
Outside micrometer.
Micromètre extérieur.
Micrometro esteriore.



Ref.							€
DM 125	0,01 mm	0-25 mm	6,5 mm	Caja	1	84214110015605	
DM 150	0,01 mm	25-50 mm	6,5 mm	Caja	1	84214110015612	
DM 175	0,01 mm	50-75 mm	6,5 mm	Caja	1	84214110015629	
DM 100	0,01 mm	75-100 mm	6,5 mm	Caja	1	84214110015636	

DIGITAL

Micrómetro exteriores.
Outside micrometer.
Micromètre extérieur.
Micrometro esteriore.

NEW



Ref.							€
640/1	0-10 mm	20 mm	0,1	Caja	1	8421411003909	
640/2	0-20 mm	20 mm	0,1	Caja	1	8421411003916	
640/3	0-20 mm	50 mm	0,1	Caja	1	8421411003923	

Medidor de espesores de bolsillo.
Pocket thickness measurer.
Mesureur d'épaisseurs de poche.
Misuratore di spessori tascabile.



Calibres,
micrómetros y
medidor de espesores

Calipers,
micrometers and
thickness measurer

Pieds à coulisse,
micromètres et
mesureur d'épaisseurs

Calibri,
micrometri e
misuratore di spessori



11889-00



G-03



2541-02



2541-01



Ref.					€
S-25	5-12 mm	Caja	1	8421411001837	

Soporte de micrómetro orientable.
Adjustable micrometer stand.
 Support de micromètre orientable.
 Supporto per micrometro orientabile.

Ref.	Ø	L				€
11889-00	--	160 mm	--	1	8421411001455	
G-03	150 mm	214 mm	--	1	8421411000212	

Transportadores de ángulos de 0-180° de acero inoxidable.
Stainless steel protractors. Range 0-180°.
 Rapporteur 0-180° en acier inoxydable.
 Goniometri capacità 0-180° in acciaio inossidabile.

Ref.				€
566	Caja	1	8421411002063	

Soporte comparador magnético.
Magnetic dial indicator stand.
 Support magnétique de comparateur.
 Supporto comparatore magnetico.

Ref.	Descripción					€
2541-01	Sin orejas	0,01	Caja	1	8421411001844	
2541-02	Con orejas	0,01	Caja	1	8421411001851	



Reloj comparador.
Dial indicator.
 Comparateur à cadran.
 Comparatore.

Ref.	Láminas	Largo				€
10008	8	100 mm	Caja	1	8421411015438	
10013	13	100 mm	Caja	1	8421411015445	
10020	20	100 mm	Caja	1	8421411015452	
20008	8	200 mm	Caja	1	8421411015469	
20013	13	200 mm	Caja	1	8421411015476	
20020	20	200 mm	Caja	1	8421411015483	
30008	8	300 mm	Caja	1	8421411015490	
30013	13	300 mm	Caja	1	8421411015506	
30020	20	300 mm	Caja	1	8421411015513	

Galgas espesores, en acero.
Thickness gauges, made of steel.
 Jauges d'épaisseur en acier.
 Spessimetri in acciaio.

Ref.	Láminas	Rango				€
178600	17	1-7 mm	●	1	8421411001622	
178700	16	7,5-15 mm	●	1	8421411001639	
179000	15	15,5-25 mm	●	1	8421411001646	

Plantillas de radios, en acero templado para cóncavos/convexos.
Fillet or radius gauges, made of tempered steel for concaves/convexes.
 Jauges à rayons en acier trempé à lames concaves/convexes.
 Raggimetri, in acciaio temperato per concavi/convessi.

Ref.	Láminas	Tipo rosca				€
3524	24	Métrica	Caja	1	8421411015537	
3528	28	Whitworth	Caja	1	8421411015544	
3552	52	Métrica y Whitworth	Caja	1	8421411015520	

Galgas para roscas, en acero trempado, 67 mm.
Screw pitch gauges, made of tempered steel, 67 mm.
Jauges pour filetages en acier trempé, 67 mm.
Contafiletta, in acciaio temperato, 67 mm.



Ref.	Medidas				€
72005	280x105x20 mm	Caja	1	8421411002513	



Perfilómetro de plástico.
Plastic profilometer.
Perfilomètre en plastique.
Perfilometro di plastica.



Ref.	Medidas				€
72001	160x85x20 mm	●	1	8421411002506	



Perfilómetro. Agujas de acero.
Profilometer. Acier.
Perfilomètre. Aiguilles en acier.
Perfilometro. Aghi in acciaio.



Ref.	mm				€
31	200	45°	--	1	8421411001868
35	150	--	--	1	8421411013281
33	250	90°	--	1	8421411001875
34	150	--	--	1	8421411001882
32	140	--	--	1	8421411013274

Puntas trazar: de acero (31 y 33), para cerámica (35). Lápiz trazador metálico, cuerpo aluminio, punta widia (34) y punta widia retráctil (32).
Engineer's scribes: made of steel (31 and 33), for ceramics (35). Metal engineer's scribes aluminium body and widia point (34) and retractable widia point (32).
Pintes à tracer: en acier (31 et 33), pour ceramique (35). Crayon traceur metallique, corps en aluminium, pointe widia (34) et pointe widia rétractile (32).
Punte per tracciare: in acciaio (31 et 33), per ceramica (35). Matite metalliche con corpo di alluminio in punta widia (34), e punta widia retrattile (32).



Ref.	DIN	mm				€
NF-220	DIN 875/1	100x70	--	1	8421411001707	
NF-220	DIN 875/1	150x100	--	1	8421411001714	
NF-220	DIN 875/1	200x130	--	1	8421411001721	
NF-220	DIN 875/1	250x160	--	1	8421411001738	
NF-220B	DIN 875/1	150x100	--	1	8421411013847	
NF-221	DIN 875/1	100x70	--	1	8421411001790	
NF-221	DIN 875/1	150x100	--	1	8421411001806	
NF-221	DIN 875/1	200x130	--	1	8421411001813	
NF-221	DIN 875/1	250x160	--	1	8421411001820	
NF-221B	DIN 875/1	150x100	--	1	8421411013854	

Escuadras de acero al carbono.
Carbon steel squares.
Equerre en acier au carbone.
Squadra di acciaio al carbonio.

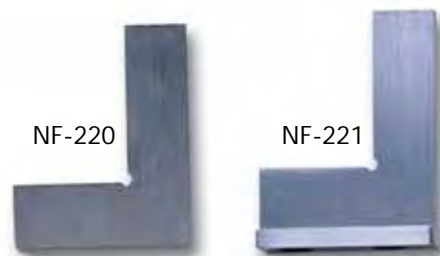

Metrología

Metrology

Métrologie

Metrologia



Metrología

Metrology

Métrie

Metrologia



T-550

Ref.	mm				8 421411 000007	€
T-300	300	300 mm	Caja	1	8421411015551	
T-550	550	500 mm	Caja	1	8421411001677	

Gramil.

Surface gauge.

Trusquin.

Truschino.



Ref.	Modelo	L			8 421411 000007	€
7/150	Patas rectas	150 mm	--	1	8421411000823	
7/200	Patas rectas	200 mm	--	1	8421411000830	
7/250	Patas rectas	250 mm	--	1	8421411000854	
8/150	Exteriores	150 mm	--	1	8421411000892	
8/200	Exteriores	200 mm	--	1	8421411000908	
8/250	Exteriores	250 mm	--	1	8421411000922	
9/150	Interiores	150 mm	--	1	8421411000953	
9/200	Interiores	200 mm	--	1	8421411000960	
9/250	Interiores	250 mm	--	1	8421411000984	

Compases de muelle.

Spring dividers.

Compas à ressort.

Compassi a molla.



Ref.	Modelo	L			8 421411 000007	€
4/200	Portalápices	200 mm	--	1	8421411013243	

Compás con portalápices.

Divider with carry-pencils.

Compas avec porte crayon.

Compass con portamatite.

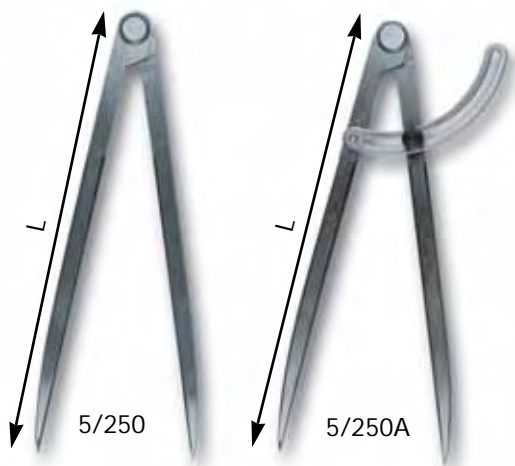

Ref.	Modelo	L			8 421411 000007	€
5/250	2 puntas	250 mm	--	1	8421411013250	
5/250A	2 puntas con regla	250 mm	--	1	8421411013267	

Top Quality

Ref.	Ø rueda	Lectura	Capacidad			€
592000	318,5 mm	m/cm	9999,9 m	99,95%	8421411003824	

Rueda de llanta de acero con recubrimiento de neopreno y bolsa de transporte.

Enameled steel rim with neoprene covering and transport bag.

Roue à jante en acier émaillé à revêtement en néoprène et sac transport.

Rotella con cerchione di acciaio smaltato con rivestimento di neoprene e borsa trasporto.



Ref.	Ø rueda	Lectura	Capacidad			€
596000	320 mm	m/dm	9999,9 m	99,95%	8421411012215	

Topómetro de metal modelo elephant y bolsa de transporte.

Elephant metallic road measuring wheel and transport bag.

Odomètre métallique elephant et sac transport.

Topometro metallico elephant e borsa trasporto.



Ref.	Ø rueda	Lectura	Capacidad			€
582000	320 mm	m/dm	9999,9 m	99,95%	8421411015650	

Topómetro con 2 botones de reset y freno.

Topometer with 2 reset push-buttons and stop.

Odomètre avec 2 boutons reset et frein.

Topometro con 2 pulsanti di reset e freno.



Ref.	Ø rueda	Lectura	Capacidad			€
575000	320 mm	m/dm/cm	9999,9 m	99,95%	8421411015001	

Topómetro con freno, rueda marcada cada cm.

Topometer with stop, wheel marked each cm.

Odomètre avec frein, roue marqué à cm.

Topometro con freno, ruota centimetrata.



Topómetros

Road measuring wheels

Odomètres

Topometri

Topómetros

Road measuring wheels

Odomètres

Topometri



Ref.	Ø rueda	Lectura	Capacidad			€
590000	320 mm	m/dm	10000 m	99,95%	8421411008232	
590001	Bolsa de lona / Fabric bag / Borse de toile / Borsa in tela				8421411008485	

Rueda de plástico ABS con recubrimiento de neopreno.

ABS plastic wheel with neoprene covering.

Roue en plastique ABS à revêtement en néoprène.

Ruota in ABS con rivestimento di neoprene.



Ref.	Ø rueda	Lectura	Capacidad			€
591000	320 mm	m/dm	10000 m	99,95%	8421411014486	

Rueda de plástico ABS con recubrimiento de neopreno.

ABS plastic wheel with neoprene covering.

Roue en plastique ABS à revêtement en néoprène.

Ruota in ABS con rivestimento di neoprene.



DIGITAL

Ref.	Ø rueda	Lectura	Capacidad			€
595000	320 mm	m/dm	10000 m	99,95%	8421411011942	

Topómetro modelo **elephant** muy ligero y bolsa de transporte.

Elephant light road measuring wheel and transport bag.

Odomètre elephant très léger et sac transport.

Topometro elephant molto leggero e borsa trasporto.



Ref.	Ø rueda	Lectura	Capacidad			€
585000	320 mm	m/dm	9999,9 m	99,95%	8421411012222	

Topómetro con luz y bolsa de transporte.

Road measuring wheel with light and transport bag.

Odomètre avec lumière et sac transport.

Topometro con contatore illuminato e borsa trasporto.



Ref.	Ø rueda	Lectura	Capacidad			€
594000	195 mm	m/dm	9999,95 m	--	8421411003848	

Rueda **Compact** de plástico ABS con recubrimiento de neopreno y bolsa de transporte.

Compact ABS plastic wheel with neoprene covering and transport bag.

Roue en plastique ABS Compact à revêtement en néoprène et sac transport.

Ruota in ABS Compact con rivestimento di neoprene e borsa trasporto.

Ref.	Ø rueda	Lectura	Capacidad			€
593000	160 mm	m/dm	1000 m	99,95%	8421411013038	

Rueda **Compact** de plástico ABS con recubrimiento de neopreno.

Compact ABS plastic wheel with neoprene covering.

Roue en plastique ABS Compact à revêtement en néoprène.

Ruota in ABS Compact con rivestimento di neoprene.



Ref.	Ø rueda	Lectura	Capacidad			€
595001	320 mm	m/dm	9999,9 m	99,95%	8421411014400	
5800	Spray fucsia				8421411014448	

Topómetro con spray marcador y bolsa de transporte. No incluye spray.

Road measuring with marking spray and transport bag. Spray not included.

Spray not included.

Odomètre avec spray marqueur et sac transport.

Spray non inclus.

Topometro con spray marcatore e borsa trasporto.

Non includere spruzzo.



Ref.	Ø rueda	Lectura	Capacidad			€
5041	570 mm	m/dm	9999,9 m	99,95%	8421411012253	

Topómetro para campo.

Measuring landwheel.

Odomètre de campagne.

Topometro per la misura dei campi.



Topómetros

Road measuring wheels

Odomètres

Topometri

Topómetros y
telescopios

Road measuring
wheels and telescope
meters

Odomètres et canne
télescopique

Topometri e misura
telescopiche, a stadia



Ref.	Ø rueda	Lectura	Capacidad			€
5200	400 mm	m/dm	9999999,9 m	99,95%	8421411012260	

Topómetro remolque con contador.
Car distance measurer with counter.
 Odomètre de remorquage avec compteur.
 Topometro a rimorchio con contatore.



Ref.	Ø rueda	Lectura	Capacidad			€
5061	165 mm	m/dm	9999,9 m	99,95%	8421411012246	

Topómetro especial para raíles.
Rail track measurer.
 Odomètre pour voie ferrée.
 Topometro misura binari.



Ref.	Max.	Min.				€
71062	3 m	0,75 m	Caja	1	8421411011171	
71064	4 m	0,90 m	Caja	1	8421411013908	
71065	5 m	1,10 m	Caja	1	8421411011188	

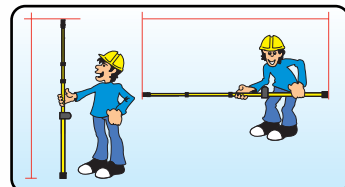

Telescopios.
Telescope meters.
 Canne télescopique.
 Misura telescopiche.

Ref.	Min.	Max.					€
Sonic-4	55 cm	13 m	99,5%±1,5 cm	●	1	8421411005590	
Sonic-6 Láser	90 cm	18 m	99,5%±1,5 cm	●	1	8421411009918	

Estimadores de distancias por ultrasonidos.

Distance estimators by ultrasounds.

Estimateurs de distances aux ultrasons.

Misuratori di distanza ad ultrasuoni.

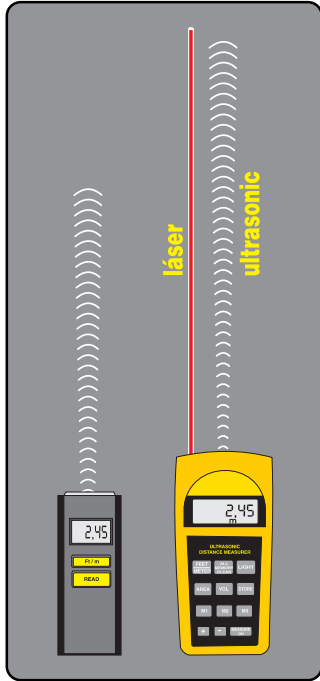

Sonic-4



Sonic-6 Láser



Medición por ultrasonidos y detector

Ultrasound measuring devices and detector

Mesure à ultrasons et détecteur

Misuratori ad ultrasuoni e rivelatore

Ref.				€
Detector-75	●	1	8421411013151	

Detector de metal, madera y corriente eléctrica.

Metal, wood and AC detector.

Détecteur de metal, bois et AC.

Rilevatore di metallo, legno e AC.

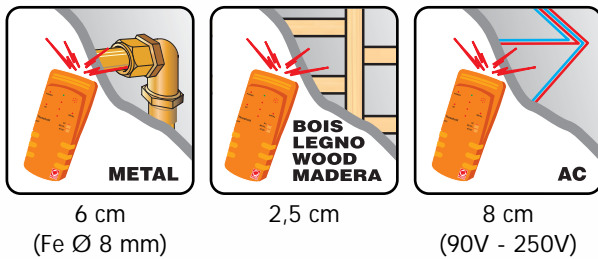



ALTA PRECISIÓN SUIZA EN MEDICIÓN-LASER

HIGH SWISS PRECISION IN LASER MEASUREMENT

HAUTE PRÉCISION SUISSE EN MESURE-LASER

ALTA PRECISIONE SUIZZERA IN MISURAZIONE LASER

-when it has to be right

Leica
Geosystems



Medición láser

Laser measuring devices

Mesure laser

Misuratori laser



LEICA DISTO A5

Ref.		Medidas				€
DISTO A5	± 2 mm	148x64x36 mm	●	1	8 421411 000007	

CARACTERÍSTICAS / CHARACTERISTICS / CARACTÉRISTIQUES / CARATTERISTICHE
 Alcance / Capacity / Distance / Portata: 0,05 m - 200 m.
 Peso / Weight / Poids / Peso: 241 gr.

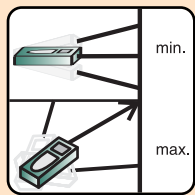

Medición continua
 Continuous measurement
 Mesure continue
 Misurazione continua



Guía trasera multifunción
 Back guide multifunction
 Guide arrière multifonctionnel
 Guida posteriore multifunzionale



Medición indirecta de alturas
 Indirect measurement heights
 Mesure indirecte d'hauteurs
 Misurazione indiretta dell'altezza



Visor para medición a larga distancia
 Viewfinder for measurement long distance
 Viseur pour mesures à grandes distances
 Visore per misurazione a lunga distanza

NEW



Medición láser

20 memorias
 memory
 mémoires
 memorie

exterior
 outdoor
 extérieure
 esteriore

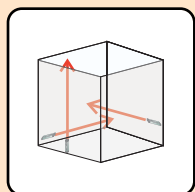
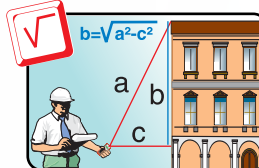

Volumenes y áreas
 Volumes and areas
 Volume et pièces
 Volumi e aree

LEICA DISTO A3

Ref.		Medidas				€
DISTO A3	± 1,5 mm	135x45x31 mm	●	1	8 421411 000007	

CARACTERÍSTICAS / CHARACTERISTICS / CARACTÉRISTIQUES / CARATTERISTICHE
 Alcance / Capacity / Distance / Portata: 0,05 m - 100 m.
 Peso / Weight / Poids / Peso: 145 gr.



Manejo sencillo
 Simple handling
 Manipulation simple
 Di facile utilizzo



Pequeño y robusto
 Small and robust
 Petit et robuste
 Piccolo e robusto



Nivel de burbuja integrado
 Integrated level of bubble
 Niveau à bulles intégré
 Livella a bolla integrata

NEW



Laser measuring devices

Mesure laser

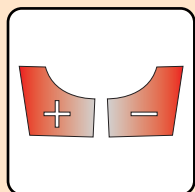

Suma y resta
 Sum and reduces
 Additionne et soustrait
 Sommare e sottrarre

19 memorias
 memory
 mémoires
 memorie

LEICA DISTO A2

Ref.		Medidas				€
DISTO A2	± 1,5 mm	124x54x35 mm	●	1	8 421411 000007	

CARACTERÍSTICAS / CHARACTERISTICS / CARACTÉRISTIQUES / CARATTERISTICHE
 Alcance / Capacity / Distance / Portata: 0,05 m - 60 m.
 Peso / Weight / Poids / Peso: 155 gr.

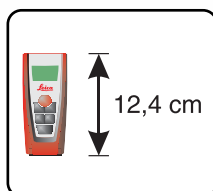

NEW



Misuratori laser

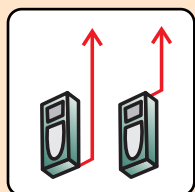

Doble inicio medición
 Double beginning measurement
 Double début de mesure
 Doppio inizio misurazione



Cutters línea
elephant pro

Elephant pro line
cutters

Outils de coupe
ligne elephant pro

Coltelli linea
elephant pro

Top Quality



Ref.							€
918	18 mm	8	ABS+Elast.	●	12	8421411013502	

recarga automática

blades self loading

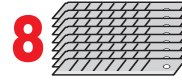

Top Quality



Ref.							€
913	18 mm	3	ABS+Elast.	●	12	8421411013519	

recarga automática

blades self loading

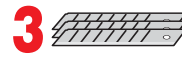

Top Quality



Ref.							€
925	25 mm	5	ABS+Elast.	●	6	8421411013533	

recarga automática

blades self loading



Top Quality



Ref.						€
909	9 mm	Metal	●	12	8421411013526	

Top Quality



Ref.					€
1083 PRO	18 mm	Caja (10)	1	8421411013588	
1083G PRO	18 mm	Caja (5)	1	8421411013571	
1025 PRO	25 mm	Caja (5)	1	8421411013564	
1021 PRO	18 mm	Caja (10)	1	8421411013557	
1011 PRO	9 mm	Caja (10)	1	8421411013540	

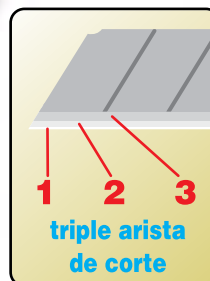

Triple arista de corte.
Triple edge of cut.
Triple bord de coupe.
Tripla bordo di taglio.

Ref.							€
908	18 mm	8	ABS+Elast.	--	24	8 421411 000007	

recarga automática

blades self loading

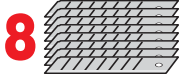

Ref.							€
903	18 mm	3	ABS+Elast.	--	24	8 421411 000007	

recarga automática

blades self loading

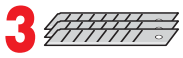

Ref.							€
811	25 mm		ABS+Elast.	●	12	8 421411 000007	



Ref.							€
812	18 mm		ABS+Elast.	●	12	8 421411 000007	



Ref.							€
813	18 mm		ABS+Elast.	●	12	8 421411 000007	



Ref.							€
807	18 mm		ABS	●	12	8 421411 000007	



Cutters línea profesional

Professional line cutters

Outils de coupe ligne professionnelle

Coltelli linea professionale



Cutters línea profesional



Ref.						€
808	18 mm	ABS	●	12	8421411010785	



Ref.						€
806	18 mm	ABS	●	12	8421411010792	

NEW



Ref.							€
525	18 mm	5	Metal+Elast.	●	10	8421411014684	

recarga automática

blades self loading



Professional line cutters



Ref.						€
803	18 mm	Metal	●	12	8421411008324	



Outils de coupe ligne professionnel



Ref.						€
899	18 mm	Metal	●	1	8421411010778	



Coltelli linea professionale



Ref.						€
703	9 mm	Metal	--	36	8421411008997	



Ref.							€
510	7 mm	10	Metal	•	10	8 421411 000007	

Cutter metálico de precisión.
Metal cutter of precision.
 Cutter métallique de précision.
 Cutter metallico di precisione.

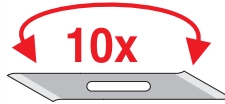

Ref.							€
967	18 mm		Metal	•	12	8 421411 013595	



Cutters línea profesional

Ref.							€
966	18 mm		Metal	•	10	8 421411 014547	



Professional line cutters

Ref.						€
410		Madera	•	10	8 421411 014714	

Cuchillo de electricista.
Electrician knife.
 Couteau électricien.
 Coltello elettricista.



Outils de coupe ligne professionnelle

Ref.							€
505	18 mm	5	Metal	•	10	8 421411 014677	

Cutter metálico plegable.
Folding metal cutter.
 Cutter métallique pliable.
 Cutter metallico pieghevole.

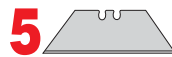

Coltelli linea professionale

Ref.	Medidas				€
625	60x45 cm	•	1	8 421411 014943	

Protector superficie para cortar.
Superficy protection to cut.
 Protection superficie de coupe.
 Protettore superficie di taglio.

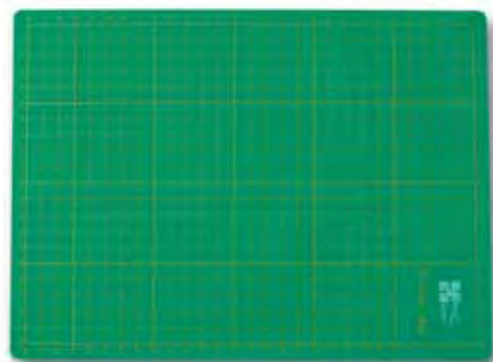
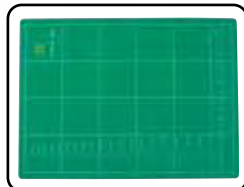



Cutters, cortavidrios, rascavidrios y hojas de recambio

Cutters, glass cutters, glass scraper and spare blades

Outils de coupe, coupe verres, gratte verres et lames

Cottelli, tagliavetro, raschiavetro e lame



Ref.						€
603	18 mm	ABS	--	12	8421411008980	
503	9 mm	ABS	--	36	8421411008973	

Ref.						€
403	18 mm	ABS	--	12	8421411009888	
103	9 mm	ABS	--	36	8421411010488	

Ref.					€
CV-100	Madera	Caja	1	8421411006610	

Cortavidrios Silberschnitt.
Silberschnitt glass cutter.
 Coupe verre Silberschnitt.
 Tagliavetro Silberschnitt.

Ref.					€
CV-150	Madera	Caja	10	8421411015698	

Cortavidrios. Corte nítido de cristal grueso. Muy resistente.
Glass cutter. Sharp cutting of thicker glass. Long life.
 Coupe verre. Coupe nette de verre épais. Très résistant.
 Tagliavetro. Taglio pulito di vetro più spesso. Molto resistente.

Ref.					€
CV-200	Madera	Caja	12	8421411006627	

Cortavidrios standard.
Standard glass cutter.
 Coupe verre standard.
 Tagliavetro standard.

Ref.						€
208	18 mm	Plástico	--	36	8421411000007	

Rascavidrios.
Glass scraper.
Gratte verre.
Raschiavetro.

Ref.						€
308	18 mm	4	Metal	●	12	8421411013601

Rascador para vitrocerámica.
Vitroceramic scraper.
Grattoir pour vitroceramique.
Raschiatore per vitroceramica.

4x

Ref.					€
1083	18 mm	Caja (10)	1	8421411008331	
1083G	18 mm	Caja (5)	1	8421411010808	
1025	25 mm	Caja (5)	1	8421411011706	
1021	18 mm	Caja (10)	1	8421411002599	
1011	9 mm	Caja (10)	1	8421411002582	

Ref.	Medidas				€
3035	250x50x70 mm	--	1	8421411014370	

Cortaingletes de aluminio (+45° / -45° / 90°).
Aluminium sawblade holder (+45° / -45° / 90°).
Support de scie en aluminium (+45° / -45° / 90°).
Supporto per sega in alluminio (+45° / -45° / 90°).

Ref.						€
901	9 mm	Plástico	--	2	8421411013618	

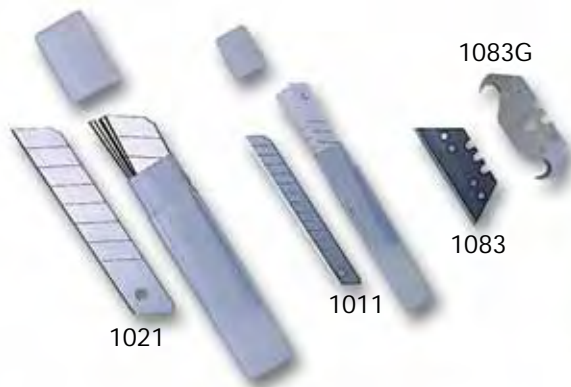

Cutters, cortavidrios,
 rascavidrios y hojas
 de recambio

Cutters, glass cutters,
 glass scraper and
 spare blades

Outils de coupe, coupe
 verres, grate verres
 et lames

Coltelli, tagliavetri,
 raschiavetro e lame

Ø INT = 22,2 mm



**CORTE EN SECO.
VELOCIDAD DE CORTE INDICADA EN CADA DISCO.**

*DRY CUTTING.
PERIPHERAL SPEED SEE TABLE ON THE DISC.*

**COUPE À SEC.
VITESSE DE COUPE INDIQUÉE A CHAQUE DISQUE.**

*TAGLIO A SECCO.
VELOCITÀ DI TAGLIO VEDERE TABELLA NEI DISCHI.*

Discos de diamante

Diamond discs

Disques diamants

Dischi diamantati



Ref.	Ø mm				€
SG-115	115	●	1	8421411007280	
SG-125	125	●	1	8421411012710	
SG-180	180	●	1	8421411012727	
SG-230	230	●	1	8421411007303	

Discos segmentados general obras. Corte rápido.

Segmented discs. Fasten cut.

Disques segmentés. Coupe rapide.

Dischi segmentati universali. Taglio rapido.



Ref.	Ø mm				€
TG-115	115	●	1	8421411007389	
TG-125	125	●	1	8421411012734	
TG-180	180	●	1	8421411012741	
TG-230	230	●	1	8421411007426	

Discos turbo. Corte limpio.

Turbo discs. Clean cut.

Disques turbo. Coupe nette.

Dischi turbo o a spirale universali. Taglio con ottima rifinitura.



Ref.	Ø mm				€
SP-115	115	●	1	8421411007334	
SP-125	125	●	1	8421411007341	
SP-180	180	●	1	8421411012758	
SP-230	230	●	1	8421411008358	

Discos segmentados profesionales. Cortan granito.

Professional segmented discs. Able to cut granite.

Disques segmentés professionnels. Couper de granite.

Dischi segmentati professionali. Per granito.



Ref.	Ø mm				€
TP-115	115	●	1	8421411007457	
TP-125	125	●	1	8421411012765	
TP-180	180	●	1	8421411007488	
TP-230	230	●	1	8421411007495	

Discos turbo profesionales. Cortan granito.

Turbo professional discs. Able to cut granite.

Disques turbo professionnels. Bons pour couper du granite.

Dischi turbo o a spirale professionali. Per granito.

Ref.	Ø mm				€
SS-115	115	●	1	8421411012772	
SS-125	125	●	1	8421411012789	
SS-180	180	●	1	8421411012796	
SS-230	230	●	1	8421411012802	

Discos segmentados premium. Corte continuado de granito.
Segmented premium discs for continued granite cutting works.

Disques premium segmentés. Coupe continué de granite.

Dischi segmentati premium per lavori di taglio continuo di granito.

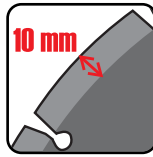

Ref.	Ø mm				€
TS-115	115	●	1	8421411012819	
TS-125	125	●	1	8421411012826	
TS-180	180	●	1	8421411012833	
TS-230	230	●	1	8421411012840	

Discos turbo premium. Corte continuado de granito.

Premium turbo discs for continued granite cutting works.

Disques turbo premium. Coupe continué de granite.

Dischi turbo premium per lavori di taglio continuo di granito.



Ref.	Ø mm				€
EDS-115	115	●	1	8421411012857	
EDS-230	230	●	1	8421411012864	

Discos electrodepositados. Corte de materiales no abrasivos (mármol...).

Electroplated discs. For cutting non-abrasive materials (marble...).

Disques electroplaqué. Pour couper des matériaux non abrasif (marbre...).

Disco elettrodepositato. Taglio di materiali non abrasivi (marmo...).



Ref.	Ø mm				€
EDC-115	115	●	1	8421411013014	
EDC-230	230	●	1	8421411013021	

Discos electrodepositados. Corte de materiales no abrasivos (mármol...).

Electroplated discs. For cutting non-abrasive materials (marble...).

Disques electroplaqué. Pour couper des matériaux non abrasif (marbre...).

Disco elettrodepositato. Taglio di materiali non abrasivi (marmo...).



Ref.	Ø mm				€
BC-115	115	●	1	8421411007532	
BC-230	230	●	1	8421411007587	

Disco banda continua. Corte de cerámicas y azulejos.

Continuos rim disc. For ceramic cutting.

Disque continue lise. Pour couper de la ceramique.

Dischi banda continua. Taglio di ceramiche e piastrelle.



Ref.	Ø mm				€
SH-230	230	●	1	8421411015186	

Disco hiperventilado. Corte de acero (hormigón armado).

Hyperventilated disc. Steel cut.

Disque hyperventilé. Coupe acier.

Disco iperventilato. Taglio acciaio.

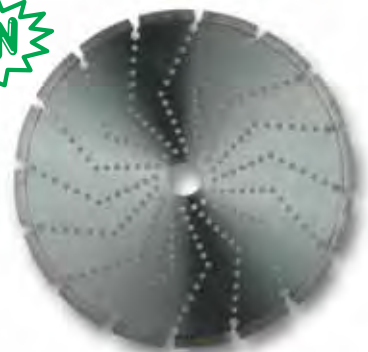

Discos de diamante

Diamond discs

Disques diamants

Dischi diamantati



Trazadoras,
plomadas y
señalización



Ref.	m	Descripción				€
125	30	Metal	Caja	1	8421411003596	
161	15	ABS	--	1	8421411006467	
162	30	ABS	Caja	1	8421411009871	
165	30	ABS-Cromado	Caja	1	8421411008218	
190	30	ABS + 115 g + nivel	●	1	8421411013076	
1530	30	ABS-Bimaterial + 115 g	●	1	8421411013359	
330	30	Metal	●	1	8421411014721	

Chalk lines, plumbs
and marking



Ref.	m	Descripción				€
164	30	ABS (3:1) + 115 g	●	1	8421411012611	
1330	30	Bimaterial (3:1) + 2 x 50 g	●	1	8421411013915	

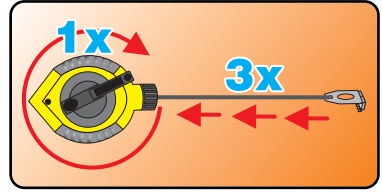

Traceurs, fils à plomb
et traçage



Ref.	m					€
730	30	250 gr	--	1	8421411014738	

Traccialinee, piombi
e segnaletica



Ref.	m					€
175	50	620 gr	--	1	8421411012628	

Ref.						€
P4B	115	●	--	1	8421411003565	
P4BR	115	●	--	1	8421411013090	
P224B	224	●	--	1	8421411009031	
P336B	336	●	--	1	8421411013083	
P1000B	1000	●	--	1	8421411006405	
P3500B	3500	●	--	1	8421411008041	

Ref.	m				€
130	30	--	1	8421411013106	

Recambio cordel.

Spare cord.

Rechange corde.

Ricambio corda traccialinee.

Ref.	gr				€
1550	500	●	1	8421411013397	

Plomada de latón.

Brass plumb.

Fil à plomb en laiton.

Piombo in ottone.

Ref.	gr				€
100/400	400	●	1	8421411005743	
100/500	500	●	1	8421411012406	
100/600	600	●	1	8421411005750	
100/700	700	●	1	8421411005767	
100/1000	1000	●	1	8421411005774	

100/700M	700	●	1	8421411009154	
100/1000M	1000	●	1	8421411009161	

M = Plomadas construidas en hierro calibrado zincado.

Plumbs made of calibrated zinc coated iron.

Fils à plomb fabriqués en acier calibré galvanisé.

Piombi in ferro calibrato zincato.

Ref.	gr				€
300/500	500	●	1	8421411012468	
300/700	700	●	1	8421411012475	
300/1000	1000	●	1	8421411012482	
300/1500	1500	●	1	8421411012499	

Plomada construida en hierro calibrado zincado. Con diábolo de madera.

Plumbs made of calibrated zinc coated iron. With wooden diable.

Fils à plomb fabriqués en acier calibré galvanisé. Avec diable en bois.

Piombi in ferro calibrato zincato. Con spago in legno.

Ref.	gr				€
200/500	500	●	1	8421411012437	
200/700	700	●	1	8421411012444	
200/1000	1000	●	1	8421411012451	

Plomada construida en hierro calibrado zincado. Con pletina.

Plumbs made of calibrated zinc coated iron. With deck.

Fils à plomb fabriqués en acier calibré galvanisé. Avec platine.

Piombi in ferro calibrato zincato. Con platino.

Ref.	gr				€
1125	125	●	1	8421411013113	
1200	200	●	1	8421411013120	
1500	500	●	1	8421411013335	

Plomada de acero.

Steel plumb.

Fil à plomb en acier.

Piombo in acciaio.



Trazadoras,
plomadas y
señalización

Chalk lines, plumbs
and marking

Traceurs, fils à plomb
et tracage

Traccialinee, piombi
e segnaletica

**Trazadoras,
plomadas y
señalización**

**Chalk lines, plumbs
and marking**

**Traceurs, fils à plomb
et traçage**

**Traccialinee, piombi
e segnaletica**



Ref.				€
500	•	1	8421411012390	

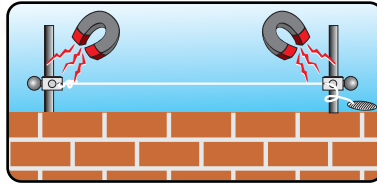

Pareja de angulares magnéticos.
Magnetic angular pair.
Paire d'angulaires magnetiques.
Coppia angolari magnetici.

Ref.	m						€
39/4	200	7 cm	0,03 mm	--	5	8421411008072	
39/5	200	7 cm	0,04 mm	Caja	1	8421411002629	
40/10	250	10 cm	0,10 mm	--	1	8421411006269	

Cintas de baliza en plástico bicolor rojo/blanco.

39/5 P: Marcada a 1 tinta, mínimo 300 rollos.

Two-coloured flagging tapes in red and white.

39/5 P: One ink printed, minimum 300 rolls.

Rubans de balisage en plastique bicouleur rouge/blanc.

39/5 P: Marquée 1 teinte, minimum 300 rouleaux.



Nastri per segnaletica di plastica bicolore rosso/bianco.

39/5 P: Marcata a 1 colore, min. 300 nastri.

Ref.	m						€
39/6	200	8 cm	0,06 mm	--	1	8421411012666	
39/AG	250	15 cm	0,04 mm	--	1	8421411012680	
39/EL	250	15 cm	0,04 mm	--	1	8421411012697	
39/GA	250	15 cm	0,04 mm	--	1	8421411012703	
39/PL	200	10 cm	0,08 mm	--	1	8421411012673	

Ref.	m	Ø mm				€
135	50	3	--	1	8421411013137	

Ref.	m				€
1100	100	--	1	8421411013144	

Ref.	↑mm	Metal				€
A030	30	Aluminio	--	1	8421411012932	
A040	40	Aluminio	--	1	8421411012949	
A050	50	Aluminio	--	1	8421411012956	
A060	60	Aluminio	--	1	8421411012963	
A080	80	Aluminio	--	1	8421411012970	
A100	100	Aluminio	--	1	8421411012987	



Letras de aluminio.

Aluminium letters.

Lettres aluminium.

Alfabeto in alluminio.



Ref.	↑mm	Metal				€
N030	30	Aluminio	--	1	8421411012871	
N040	40	Aluminio	--	1	8421411012888	
N050	50	Aluminio	--	1	8421411012895	
N060	60	Aluminio	--	1	8421411012901	
N080	80	Aluminio	--	1	8421411012918	
N100	100	Aluminio	--	1	8421411012925	



Números de aluminio.

Aluminium numbers.

Numéros aluminium.

Numeri in alluminio.



Ref.	Medida	Dimensiones				€
100.S2	2 mm	6x65 mm	Caja	1	8421411010297	
100.S3	3 mm	6x65 mm	Caja	1	8421411010303	
100.S4	4 mm	7x65 mm	Caja	1	8421411010310	
100.S5	5 mm	8x65 mm	Caja	1	8421411010327	
100.S6	6 mm	9x75 mm	Caja	1	8421411010334	
100.S8	8 mm	11x76 mm	Caja	1	8421411010358	
100.S10	10 mm	12x80 mm	Caja	1	8421411010365	
100.S12	12 mm	14x80 mm	Caja	1	8421411010372	

123



101.S2	2 mm	6x65 mm	Caja	1	8421411010396	
101.S3	3 mm	6x65 mm	Caja	1	8421411010402	
101.S4	4 mm	7x65 mm	Caja	1	8421411010419	
101.S5	5 mm	8x65 mm	Caja	1	8421411010426	
101.S6	6 mm	9x75 mm	Caja	1	8421411010433	
101.S8	8 mm	11x76 mm	Caja	1	8421411010440	
101.S10	10 mm	12x80 mm	Caja	1	8421411010457	
101.S12	12 mm	14x80 mm	Caja	1	8421411010464	



ABC

Juegos para marcar de abecedarios (101.S) y numeraciones (100.S).

Marks to stamp, letters (101.S) and numbers (100.S).

Marques à frapper de lettres (101.S) et numéros (100.S).

Punzoni per marcare serie alfabeto (101.S) e numeri (100.S).

Ref.	↑cm	Franjas Blancas				€
880032	32	1	--	5	8421411002667	
880050	50	2	--	1	8421411002674	



Trazadoras,
plomadas y
señalización

Chalk lines, plumbs
and marking

Traceurs, fils à plomb
et tracage

Traccialinee, piombi
e segnalética

Marcaje

Marking

Traçage

Marcatori



Ref.	ml		Fluor				€
5810	500	○	--	--	6	8421411012536	
5811	500	●	--	--	6	8421411012543	
5812	500	●	●	--	6	8421411012550	
5813	500	●	●	--	6	8421411012567	
5814	500	●	●	--	6	8421411012574	
5815	500	●	●	--	6	8421411012581	
5816	500	●	●	--	6	8421411012598	
5817	500	●	●	--	6	8421411012604	

5700	500	●	●	--	6	8421411015322	
------	-----	---	---	----	---	---------------	--



Spray de pintura fluorescente.
Fluorescent painting spray.
 Spray de peinture fluorescente.
Spray di pittura fluorescente.



Ref.					€
480	○	Caja	10	8421411006719	
481	●	Caja	10	8421411006733	
482	●	Caja	10	8421411006757	
485	●	Caja	10	8421411011195	

Tubos marcadores de pintura indeleble.
Tube of quick drying indelible paint.
 Tube marqueur à peinture indélébile à séchage rapide.
Tubi di pittura indelebile.



Ref.	mm						€
798	95	12 mm	●	Caja	12	8421411008096	
798	95	12 mm	●	Caja	12	8421411008102	

Tizas de cera de uso universal.
Wax crayon universal use.
 Craie de cire de usage universel.
Gessi a cera di uso universale.



Ref.	mm						€
795	120	11 mm	●	Caja	12	8421411008560	
796	120	11 mm	●	Caja	12	8421411008577	
797	120	11 mm	●	Caja	12	8421411009864	

Tizas de cera para madera.
Wax crayon for wood.
 Craie de cire pour bois.
Gessi a cera per legno.



Ref.	mm						€
680	100	9,5 mm	○	Caja	12	8421411013977	
780	100	12 mm	○	Caja	12	8421411013984	



Ref.	mm	mm				8 421411 000007	€
790	100	10 mm	○	Caja (50)	1	8421411008546	
791	100	10 mm	○	Caja (12)	1	8421411008553	

Tizas para metales.

Wax crayon for metals.

Craie pour métaux.

Gessi per metalli.

Ref.	mm	mm				8 421411 000007	€
345	80	10 mm	○	Caja (100)	1	8421411008751	

Tizas común.

Comun chalk.

Craie.

Gessi comuni.

Ref.						8 421411 000007	€
381		●		Caja	10	8421411006788	
382		●		Caja	10	8421411006795	
383		●		Caja	10	8421411006801	

Rotulador de tinta indeleble.

Marker with indelible ink.

Marqueur à encre indelebile.

Pennarello con inchiostro indelebile.

Ref.						8 421411 000007	€
371	●	●	--	Caja	12	8421411008799	
372	●	●	--	Caja	12	8421411008805	
373	●	●	--	Caja	12	8421411008812	
361	●	--	●	Caja	12	8421411008768	
362	●	--	●	Caja	12	8421411008775	
363	●	--	●	Caja	12	8421411008782	

Rotulador de tinta indeleble de secado rápido.

Marker with quick drying indelible ink.

Marqueur à encre indélébile à séchage rapide.

Pennarello indelebile ad asciugamento rapido.

Ref.						8 421411 000007	€
581	●	Gold (5 u.)	●	1	8421411013793		
582	●	Silver (5 u.)	●	1	8421411013809		
681	●	Cap Off		Caja	12	8421411013816	
682	●	Cap Off		Caja	12	8421411013823	
683	●	Cap Off		Caja	12	8421411013830	



Rotulador CAP OFF, puede estar sin capuchón 24 h.

Marker CAP OFF, it can stay opened during 24 h.

Marqueur CAP OFF, peut être sans capuchon 24 h.

Pennarello CAP OFF, può rimanere senza tappo per 24 ore.

Ref.		Ø mm				8 421411 000007	€
118	●	Colibri	1,5	--	10	8421411015353	
119	●	Colibri	1,5	--	10	8421411015360	
120	●	Colibri	1,5	--	10	8421411015377	

Rotulador para marcar sitios profundos.

Deep sites marker.

Marqueur pour endroits profonds.

Pennarello per marcare in profondità.



Marcaje

Marking

Tracage

Marcatori



Ref.	mm	Descripción				€
180	180	De carpintero	Caja	144	8421411006542	
250	250	De carpintero	Caja	144	8421411006849	
255	250	Extra duro	Caja	144	8421411012352	
300	180	Bicolor (rojo y azul)	Caja	144	8421411007181	
6365	180	Superficies mojadas	--	12	8421411014325	
1690	180	Para cristales	--	12	8421411014332	

3180	180	De carpintero	Skin (3 u.)	1	8421411006863	
3250	250	De carpintero	Skin (3 u.)	1	8421411006870	
3255	250	Extra duro	Skin (3 u.)	1	8421411016015	
3300	180	Bicolor (rojo y azul)	Skin (3 u.)	1	8421411010754	

Refs. 180, 250, 3180, 3250: Carpintero / *Carpenter* / *Menuisier* / *Falegname*
 Refs. 255, 3255: Extra duro / *Extra hard* / *Extra dur* / *Extra dure*
 Refs. 300, 3300: Bicolor / *Two colours* / *Deux couleurs* / *Bicolore*
 Ref. 6365: Superficies mojadas / *Garden* / *Superficie mouillée* / *Materiali bagnati*
 Ref. 1690: Cristales / *Glass* / *Verre* / *Vetro*

Ref.	mm	Descripción				€
334S	240	100% Copiativo de tinta	--	100	8421411008903	
334	240	1/3 Lápiz Copiativo 2/3 Mina Grafito	--	100	8421411008119	
6363	175	Para cristales, plástico, metal y papel	--	12	8421411008911	
1695	175	Para superficies mojadas	--	12	8421411008928	
331	300	Extra duro para piedra	--	100	8421411008898	
333	200	Ovalado (carpintero profesional)	--	100	8421411011034	
1174	240	Triangular	--	1	8421411015384	
4710	175	Bicolor Ø 4 mm (rojo y azul)	--	1	8421411015391	
4715	175	Bicolor Ø 6,25 mm (rojo y azul)	--	1	8421411015407	

Ref. 334S: Copiativo / *Copying* / *Copiant* / *Copiativo*
 Ref. 334: 1/3 Copiativo 2/3 Grafito / *1/3 Copying 2/3 Graphite*
1/3 Copiant 2/3 Graphite / *1/3 Copiativo 2/3 Grafite*
 Ref. 6363: Todas superficies / *All surfaces* / *Toutes surfaces* / *Tutte superfici*
 Ref. 1695: Superficies mojadas / *Garden* / *Superficie mouillée* / *Materiali bagnati*
 Ref. 331: Extra duro / *Extra hard* / *Extra dur* / *Extra dure*
 Ref. 333: Ovalado / *Oval* / *Ovale* / *Ovale*
 Ref. 1174: Triangular / *Triangular* / *Triangulaire* / *Triangulare*
 Refs. 4710, 4715: Bicolor / *Two colours* / *Deux couleurs* / *Bicolore*

Ref.	mm	Descripción				€
1772	95	Grafito	--	1	8421411015346	

Mina de grafito Ø 12 mm.
Graphite stick Ø 12 mm.
 Mine de graphite Ø 12 mm.
 Mina in grafite Ø 12 mm.

Ref.	mm	Descripción				€
7166	115	Portaminas	--	1	8421411015339	

Portaminas. Válido para ref. 1772 (pág. 76) y ref. 345 (pág. 75).
Crayon holder. For ref. 1772 (pag. 76) and ref. 345 (pag. 75).
 Porte-mines. Valide pour ref. 1772 (pag. 76) et ref. 345 (pag. 75).
 Portamine. Valido per ref. 1772 (pag. 76) e ref. 345 (pag. 75).

Ref.	mm	Descripción				€
18700	135	Portaminas	--	10	8421411014639	
18701	115	Recambio 10 minas	--	10	8421411014646	

Portaminas. Mina de grafito Ø 5,5 mm.
Crayon holder. Graphite stick Ø 5,5 mm.
 Porte-mines. Mine de graphite Ø 5,5 mm.
 Portamine. Mina in grafite Ø 5,5 mm.

Ref.	Ø mm	Aumentos				€
MD-9202	50	3,5x	Caja	1	8421411007754	
MD-9203	65	2,5x	Caja	1	8421411007761	
MD-9205	90	2x	Caja	1	8421411007778	
9165F	130	1,8x	Caja	1	8421411012079	

Lupas con mango de plástico. Ref. 9165F: con mordaza, brazo de 1 m y con luz fluorescente de 22 W.
Magnifying with plastic handle. Ref. 9165F: with jaw, 1 m long arm and 22 W light.

Loupe avec manche en plastique. Ref. 9165F: avec mâchoire, bras de 1 m et lumière de 22 W.

Lente con impugnatura in plastica. Ref. 9165F: con morsetto, braccio da 1 m e con luce da 22 W.

MD-9205



Ref.	Medidas	Aumentos				€
9270	10x10 mm	9x	Caja	1	8421411007808	
9271	15x15 mm	7x	Caja	1	8421411007815	
9273	25x25 mm	6x	Caja	1	8421411017822	

Cuentahilos metálicos.

Magnifying glass.

Compte-fil.

Contafili metallico.



Ref.					€
082371	--	Caja	1	8421411006702	
941	1/100 seg.	Caja	1	8421411009369	

Contador manual de cuatro dígitos (082371). Cronómetro digital (941).

4 digit manual counter (082371). Digital cronometer (941).

Compteur manuel a 4 chiffres (082371). Cronometre digital (941).

Contatore manuale a 4 cifre (082371). Cronometro digitale (941).

082371



Ref.		Medidas				€
206	30	58x42x26 mm	Caja	1	8421411014707	

Podómetro.

Podometer.

Podomètre.

Contapassi.



Ref.					€
597142	1:20/40/80/100/250/500/750/1000 x 1000	Caja	1	8421411002834	

Curvometro con mango.

Map measurer.

Curvimètre à manche.

Curvimetro con manico.



Ref.	Tipo				€
891	Lensática	●	1	8421411009345	
809	de Bolsillo	Caja	1	8421411009338	

Brújulas.

Compass.

Boussole.

Bussola.



Varios

Miscellaneous

Divers

Articoli vari

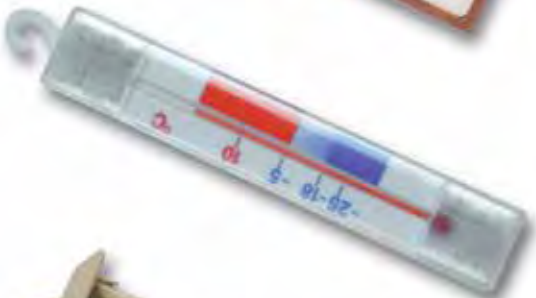

Ref.	mm	Escalas				€
271130	100	1:20/25/50/75/100/125	Caja	1	8421411008256	
271131	300	1:20/25/50/75/100/125	Caja	1	8421411008263	
271132	300	1:100/200/250/300/400/500	Caja	1	8421411008270	

Escalímetros triangulares de plástico.

Triangular plastic scale rulers.

Règle des échelles triangulaire.

Scalimetro triangolare di plastica.

Ref.	mm	Escalas				€
2030	300	1:20/25/50/75/100	Caja	1	8421411014363	

Escalímetro de aluminio.

Aluminium scale rules.

Règle d'aluminium.

Scalimetro in alluminio.

Ref.	mm	Escalas				€
2130	300	1:2,5/5/10/20/50/100	Caja	1	8421411014998	

Escalímetro de aluminio con escala móvil.

Aluminium scale rules with movable scale.

Règle aluminium avec échelle mobile.

Scalimetro in alluminio con scala girevole.



Ref.	Medidas				€
419	233x55 mm	●	1	8421411007709	

Termómetro para exteriores de plástico.

Plastic outside thermometer.

Termomètre d'extérieurs en plastique.

Termometro per esterni in plastica.

Ref.	Medidas				€
404	198x43 mm	●	1	8421411007679	

Termómetro para interiores de plástico.

Plastic inside thermometer.

Termomètre d'intérieurs en plastique.

Termometro di plastica per interni.

Ref.	Medidas				€
406	150x40 mm	●	1	8421411007686	

Termómetro para interiores de plástico.

Plastic inside thermometer.

Termomètre d'intérieurs en plastique.

Termometro di plastica per interni.

Ref.	Medidas				€
409	150x24 mm	Caja	1	8421411007693	

Termómetro para nevera.

Thermometer for refrigerator.

Termomètre pour frigo.

Termometro per frigoriferi.

Ref.	Medidas				€
282	228x82 mm	●	1	8421411007655	

Termómetro de plástico de máx-min para exteriores e interiores.

Plastic inside thermometer.

Termomètre d'intérieurs en plastique.

Termometro di plastica per interni.

Ref.	Medidas				€
520	175x39x79 mm	●	1	8 421411 000007 8421411015056	

Termómetro por infrarrojos sin contacto. Rango de temperatura -20≈520°C / -4≈978°F. Precisión ±2%. Coeficiente óptico (relación distancia:diámetro del objetivo) 8:1. Puntero laser para medir con precisión. Display digital.

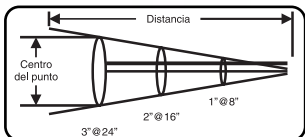

Infrared thermometer non contact. Temperature range -20≈520°C / -4≈978°F. Accuracy ±2%. Distance to spot size 8:1. Laser pointer for accurate use. Digital display.

Thermomètre à infrarouges sans contact. Température -20≈520°C / -4≈978°F. Précision ±2% coefficient optique 8:1. Pointe laser pour mesure précise. Display digital.

Termometro infrarossi -20≈520°C / -4≈978°F. Precisione ±2%. Coefficiente ottico (relazione distanza: diametro dei obiettivi) 8:1. Indicatore laser di precisione. Display digitale.



Ref.	Medidas				€
1032	310 mm	--	1	8 421411 000007 8421411009383	

Termómetro industrial ideal para líquidos calientes de -10°/120°C, con red plástica de protección.

Industrial thermometer hot liquids from -10°/120°C.

Thermomètre industriel pour liquides chaudes -10°/120°C.

Termometro industriale per liquidi caldi da -10°/120°C con rete di protezione in plastica.



Ref.	Medidas				€
5989	120x3,5 mm	●	1	8 421411 000007 8421411009390	

Termómetro industrial con sonda resistente a grandes temperaturas -50°/150°C.

Industrial thermometer digital display. High temperature -50°/150°C.

Thermomètre digital resistant aux hautes températures -50°/150°C.

Termometro industriale con sonda resistenti a grandi temperature -50°/120°C.



Ref.	Capacidad				€
995	0-40 L/m²	●	1	8 421411 000007 8421411009376	

Pluviómetro de lectura directa.

Pluviometer direct reading.

Pluviomètre de lecture directe.

Pluviometro a lettura diretta.



Ref.	Capacidad				€
705	70x75 mm	Caja	1	8 421411 000007 8421411007730	

Termómetro para hornos. Estuche metálico resistente a altas temperaturas (0-300°C).

Oven thermometer. Metal casing. High temperature resistance (0-300°C).

Thermomètre pour le four. Boîtier metal. Résistante aux températures extrêmes (0-300°C).

Termometro per forni. Astuccio metallico. Resistente ad alte temperature (0-300°C).



Ref.	Medidas				€
5821	100x108 mm	Caja	1	8 421411 000007 8421411012062	

Termo-higrómetro digital, gran pantalla LCD. Memoria máxima y mínima. Soporte de pared y sobremesa.

Digital thermo-hygrometer, big LCD display. Maximum and minimum memory. Wall and table support.

Thermo-higromètre digital, grande écran LCD. Mémoire maximum et minimum. Support pour paroi et table.

Termo-higrometro digitale, display LCD. Memoria massima e minima. Supporto per pareti e tavoli.



Ref.	Medidas				€
5822	75x63 mm	Caja	1	8 421411 000007 8421411009048	

Termómetro digital interior/exterior. Con memoria de máximas y mínimas.

Digital thermometer for outside/inside. With memory for max-min.

Thermomètre digital pour extérieurs et intérieurs. Avec mémoire pour max-min.

Termometro digitale per interni ed esterni con memoria di massima e minima.



Ref.	Medidas				€
793	120x50 mm	Caja	1	8 421411 000007 8421411007747	

Termómetro con sonda especial para asados, temperatura exacta en el centro de la carne.

Thermometer with probe special for roast.

Thermomètre avec sonde. Special pour rôti.

Termometro con sonda stabilisce la temperatura esatta al centro delle carni.



Varios

Miscellaneous

Divers

Articoli vari



Ref.	mm	mm	Kg			8 421411 000007	€
M/90	100	125 mm	7	Caja	1	8421411007952	
M/91	125	150 mm	11	Caja	1	8421411007969	
M/92	150	200 mm	17	Caja	1	8421411007976	
M/93	175	220 mm	26	Caja	1	8421411007983	

Tornillo de banco construido en acero forjado C43 de gran dureza y resistencia.



Ref.	mm	mm	Kg			8 421411 000007	€
N-141	80	100 mm	4	Caja	1	8421411007990	
N-142	110	120 mm	7	Caja	1	8421411008003	
N-143	130	140 mm	11	Caja	1	8421411008010	
N-144	150	155 mm	15,5	Caja	1	8421411008027	

Tornillo de banco construido en acero. Dispone de una gran base utilizable como yunque. Mordazas forjadas con sistema de regulación para una mejor precisión en el desplazamiento.



Ref.	mm	mm				8 421411 000007	€
E-41	60	70 mm	Caja	1	8421411011201		
E-42	80	80 mm	Caja	1	8421411011218		
E-43	100	110 mm	Caja	1	8421411011225		
E-44	120	150 mm	Caja	1	8421411011232		
E-45	150	180 mm	Caja	1	8421411011249		

Mordaza de fundición especial, para taladro. Con bocas prismáticas forjadas y rectificadas aplicables a taladros pequeños y medianos.



Ref.	mm					8 421411 000007	€
4310-01	80 mm	Caja	1	8421411011256			
4310-02	110 mm	Caja	1	8421411011263			
4310-03	130 mm	Caja	1	8421411011270			

Mordaza en acero forjado rectificado con una ranura en "V" vertical y horizontal.



Ref.	Kg	mm				8 421411 000007	€
T/105	20	465	Caja	1	8421411011287		
T/106	30	520	Caja	1	8421411011294		

Yunque de fundición.



Expositores e
implantaciones

Displays and
implantations

Présentoirs et
implantations

Espositori ed
instaurazioni



Implantación / *Implantation* / *Implantation* / *Instaurazione*



Ref. G-180
(1790x805x410 mm)



Ref. F-12
(700x530x300 mm)



Ref. F-25
(530x270x300 mm)



Ref. F-30
(890x605x200 mm)



Ref. M-150
(1590x460x355 mm)



Ref. E-905
(1730x470 mm)

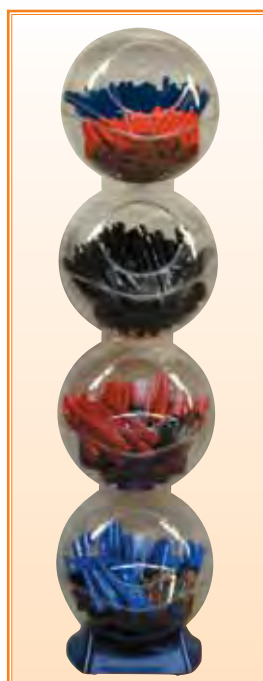

Ref. E-910
(1000x250 mm)

AENOR



Empresa Registrada

ER-0642/2001

ISO 9001:2000

empresa registrada
medid precisión, s.a.



www.medid.es

MEDID PRECISION, S.A.
c/ Rec Comtal, 9
08003 BARCELONA (Spain)

VENTAS EXPORT

Tels.: 933 190 966 / 681 Tel.: (+34) 933 190 450
Fax: 933 199 502 Fax: (+34) 933 190 558
E-mail: ventas@medid.es E-mail: export@medid.es

