

Table 5. Flange dimensions PN 10 according to DIN 2532.

32.

DN	D	b	k	d4	d2	
50	165	20	125	102	18	4 · M16
65	185	20	145	122	18	4 · M16
80	200	22	160	138	18	8 · M16
100	220	24	180	153	18	8 · M16
125	250	26	210	188	18	8 · M16

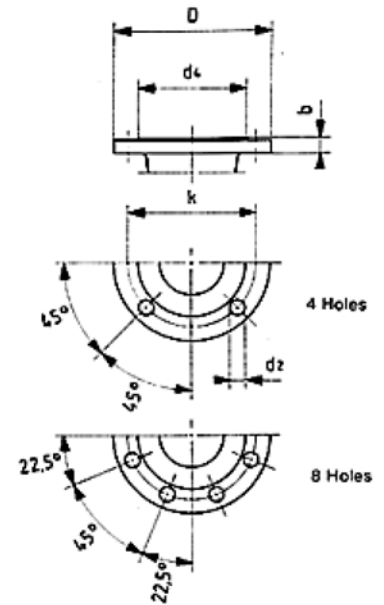

Table 6. Overall dimensions at 2.950 r.p.m.

Model IAC	MOTOR		FLANGES		PUMP						FIXATION				Weight (kg.)
	HP	Size	DNa	DNI	a	a1	f	k (1)	h1	x	m6	m7	n7	s3	
50-165	3	90L					158	282							47
50-163	4	100L					170	306							53
50-161	5,5	112M	50	50	180	160	170	328	90	100	125	80	86	M 10	57
50-161	7,5	132S					195	369							97
65-205	7,5	132S					203	369							102
65-203	7,5	132S					203	369							102
65-203	10	132S					203	369							102
65-203	12,5	132M					203	407							123
65-201	10	132S	65	65	215	200	203	369	110	100	152	95	112	M 10	102
65-201	12,5	132M					203	407							123
65-201	15	160M					235	475							145
65-201	20	160M					235	475							145
80-206	15	160M						475							163
80-204	15	160M						475							163
80-204	20	160M	80	80	250	225	235	475	130	140	187	105	148	M 12	163
80-202	20	160M						475							163
80-202	25	160L						519							187

Dimensions in mm.

(1) Indicative dimensions.